

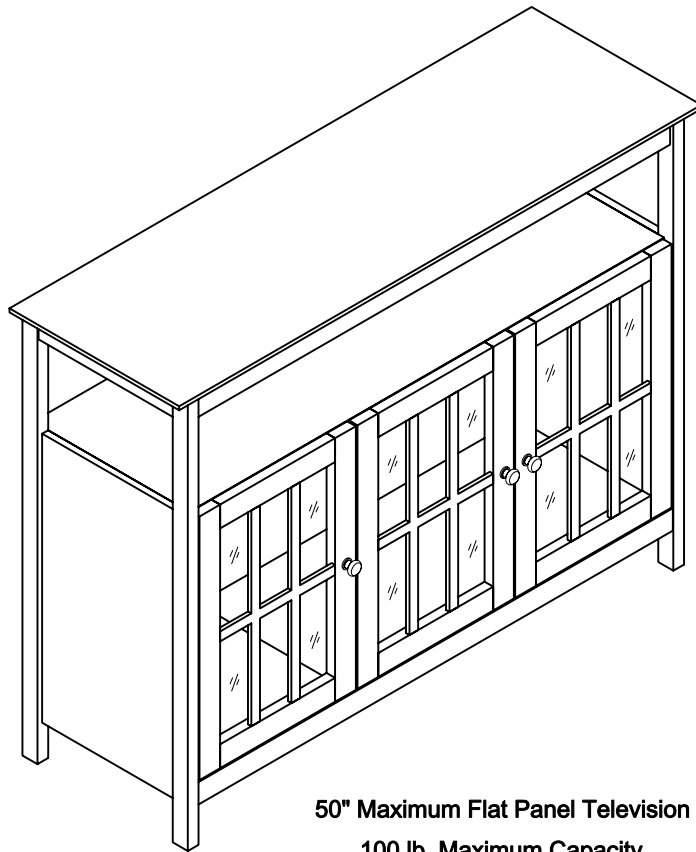









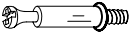





DELUXE 48" TV STAND



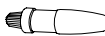

50" Maximum Flat Panel Television
100 lb. Maximum Capacity

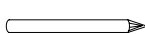
HARDWARE LIST

CODE	NAME	FIGURE	Q'TY
A	CAM LOCK (Ø15*9mm)		18PCS
B	CAM BOLT (Ø6.5*35mm)		18PCS
C	WOOD DOWEL (Ø8*30mm)		20PCS
D	WOOD SCREW (Ø7*25mm)		2PCS
E	LARGE WOOD SCREW (Ø7*38mm)		3PCS
F	KNOB		3PCS
G	KNOB SCREW (Ø4*19mm)		3PCS
H	ROUND HEAD SCREW (Ø3*15mm)		28PCS
I	SHELF SUPPORT		8PCS
J	SIDE HINGE		4PCS
K	MIDDLE HINGE		2PCS
L	FLAT HEAD SCREW(Ø3*15mm)		24PCS
M	WIRE CAP		1PC
N	WOOD GLUE		1PC
O	ALLEN WRENCH		1PC
P	COLOR STICK		1PC

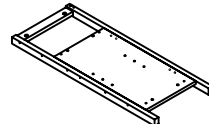
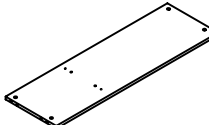
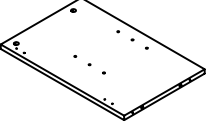
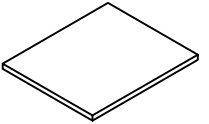
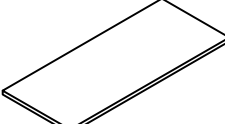
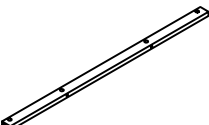
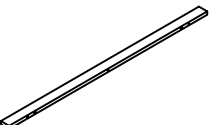
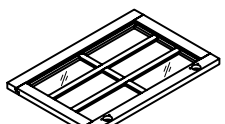
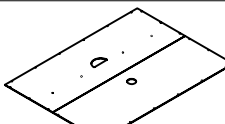
PARTS LIST

CODE	NAME	FIGURE	Q'TY
④	RIGHT SIDE PANEL		1PC
⑤	FIXED PANEL		1PC
⑥	VERTICAL DIVIDER		1PC
⑦	LEFT ADJUSTABLE SHELF		1PC
⑧	RIGHT ADJUSTABLE SHELF		1PC
⑨	FRONT CROSS BAR		1PC
⑩	BACK CROSS BAR		1PC
⑪	DOOR		3PCS
⑫	BACK PANEL		1PC
⑬	FOOT		1PC

PARTS LIST

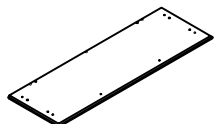
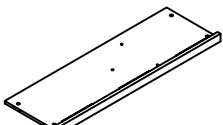
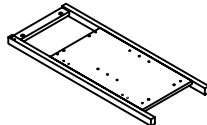
CODE	NAME	FIGURE	Q'TY
①	TOP PANEL		1PC
②	BOTTOM PANEL		1PC
③	LEFT SIDE PANEL		1PC

Assembling the unit with camlocks and wood dowels.

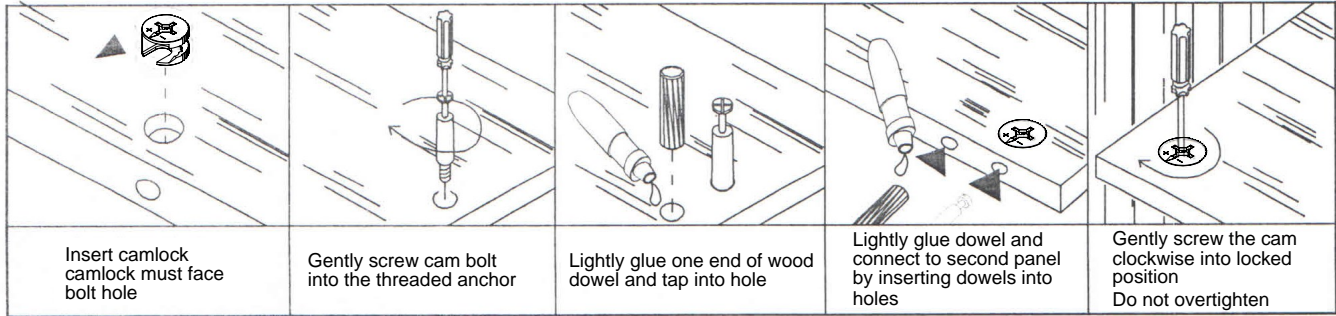

STEP 1

A x 2PCS

B x 2PCS

C x 2PCS

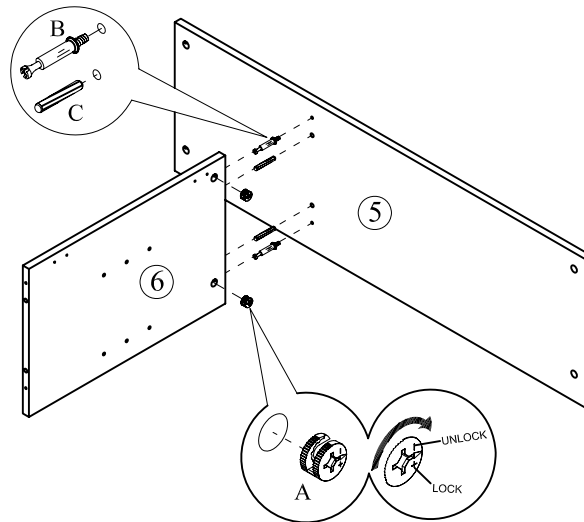

1. Attach Fixed Panel ⑤ to Vertical Divider ⑥ using Wood Dowels (C), Cam Bolts (B), and Cam Locks (A) as shown.

STEP 2

C x 2PCS

D x 2PCS

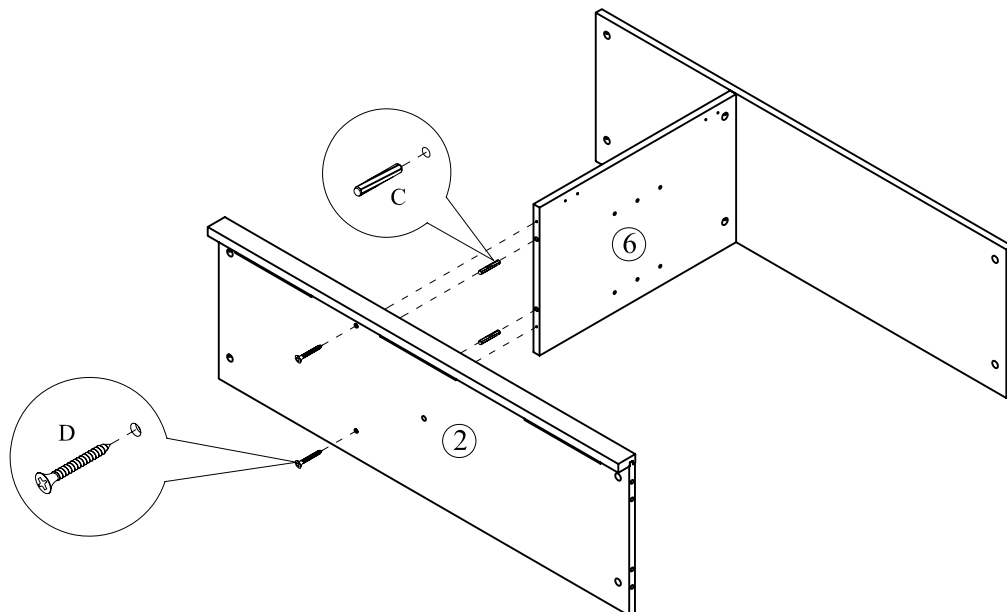

1. Insert Wood Dowels (C) into Vertical Divider ⑥ and attach it to Bottom Panel ② using Wood Screws (D).

STEP 3

A x 4PCS
B x 4PCS
C x 4PCS

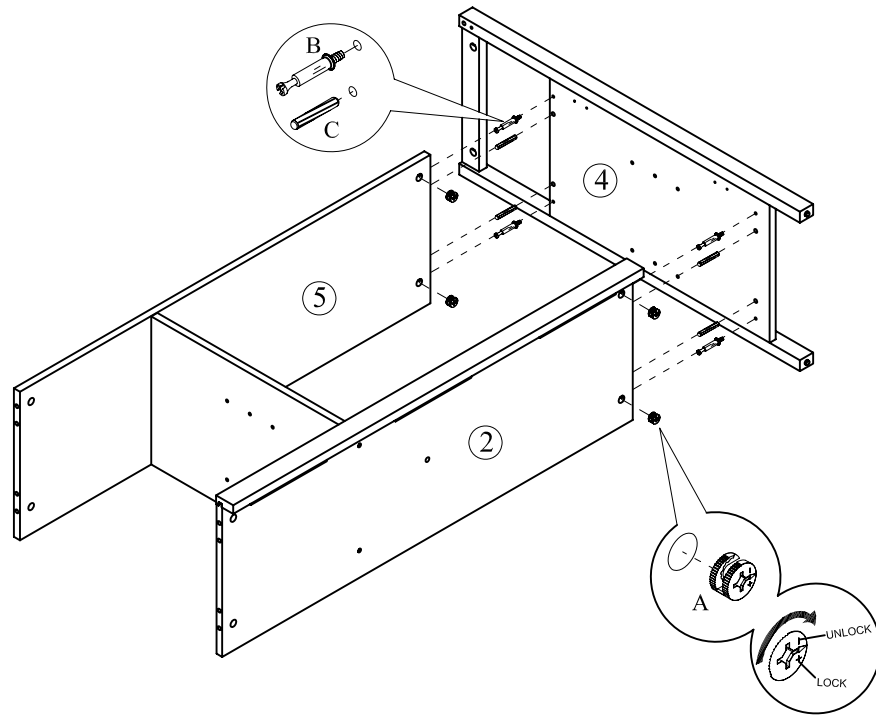

1. Attach Right Side Panel ④ to Assembly using Wood Dowels (C), Cam Bolts (B), and Cam Locks (A) as shown.

STEP 4

A x 6PCS
B x 6PCS
C x 6PCS

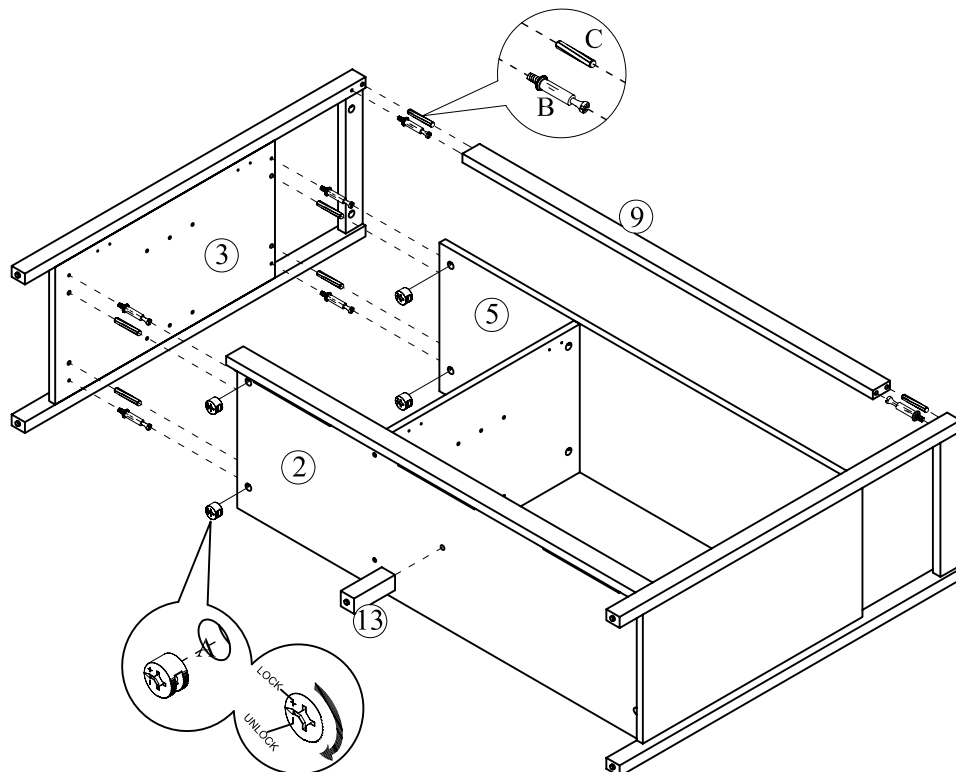

1. Attach Left Side Panel ③ and Front Cross Bar ⑨ to Assembly using Wood Dowels (C), Cam Bolts (B), and Cam Locks (A) as shown.

2. Attach Foot ⑬ to Bottom Panel ②.

STEP 5

C x 2PCS
E x 3PCS

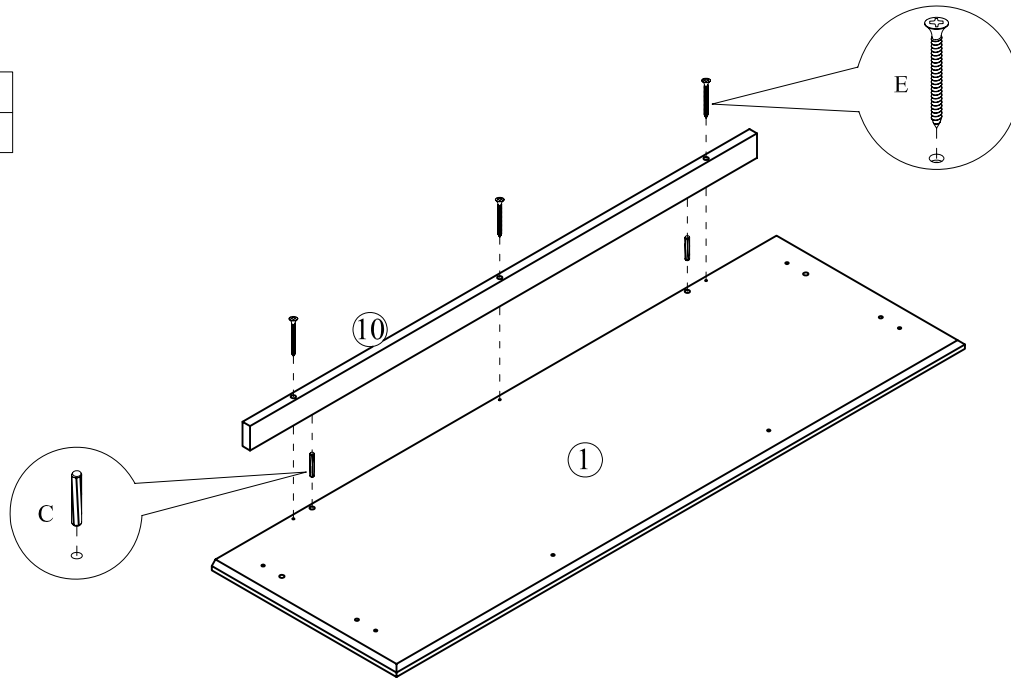

1. Attach Back Cross Bar ⑩ to Top Panel ① using Wood Dowels (C) and Large Wood Screws (E).

STEP 6

A x 6PCS
B x 6PCS
C x 4PCS

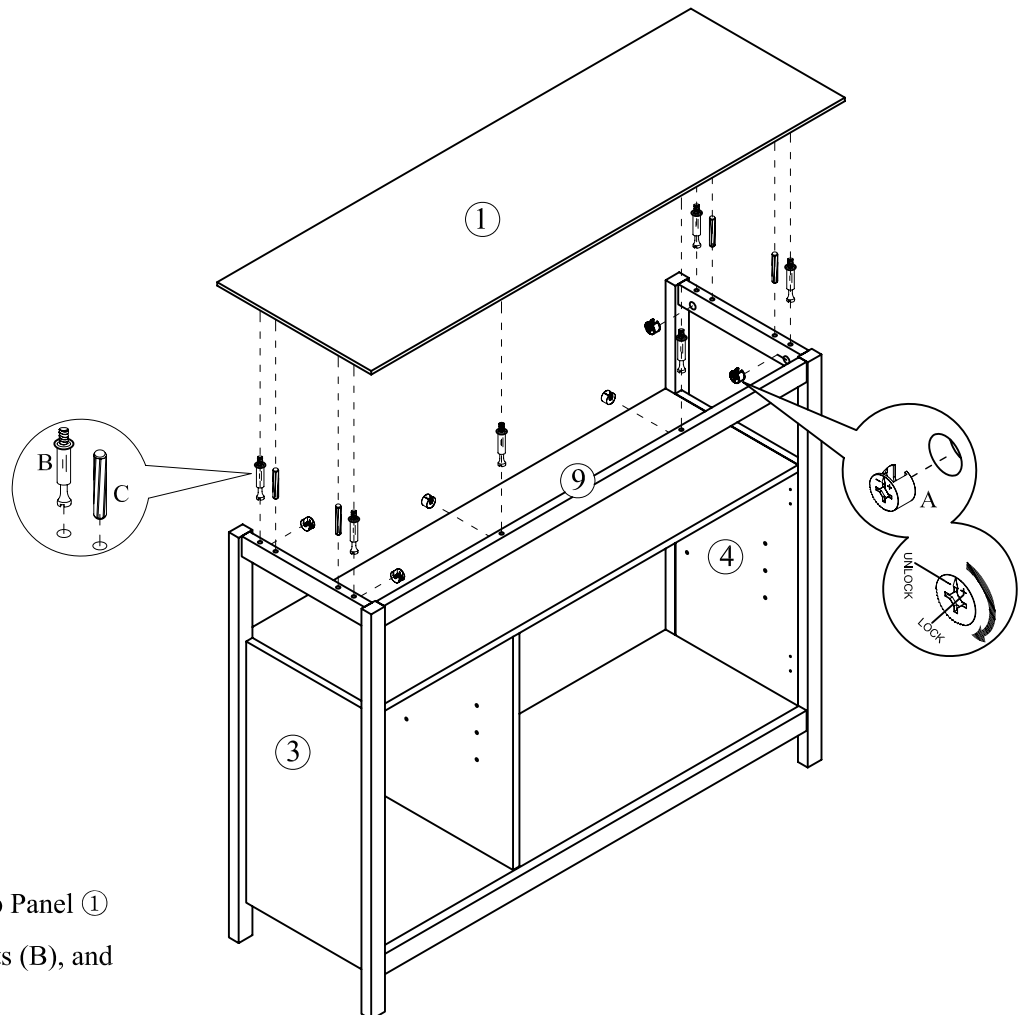

1. Place unit upright and attach Top Panel ① using Wood Dowels (C), Cam Bolts (B), and Cam Locks (A) as shown.

STEP 7

J x 4PCS
K x 2PCS
L x 12PCS
F x 3PCS
G x 3PCS

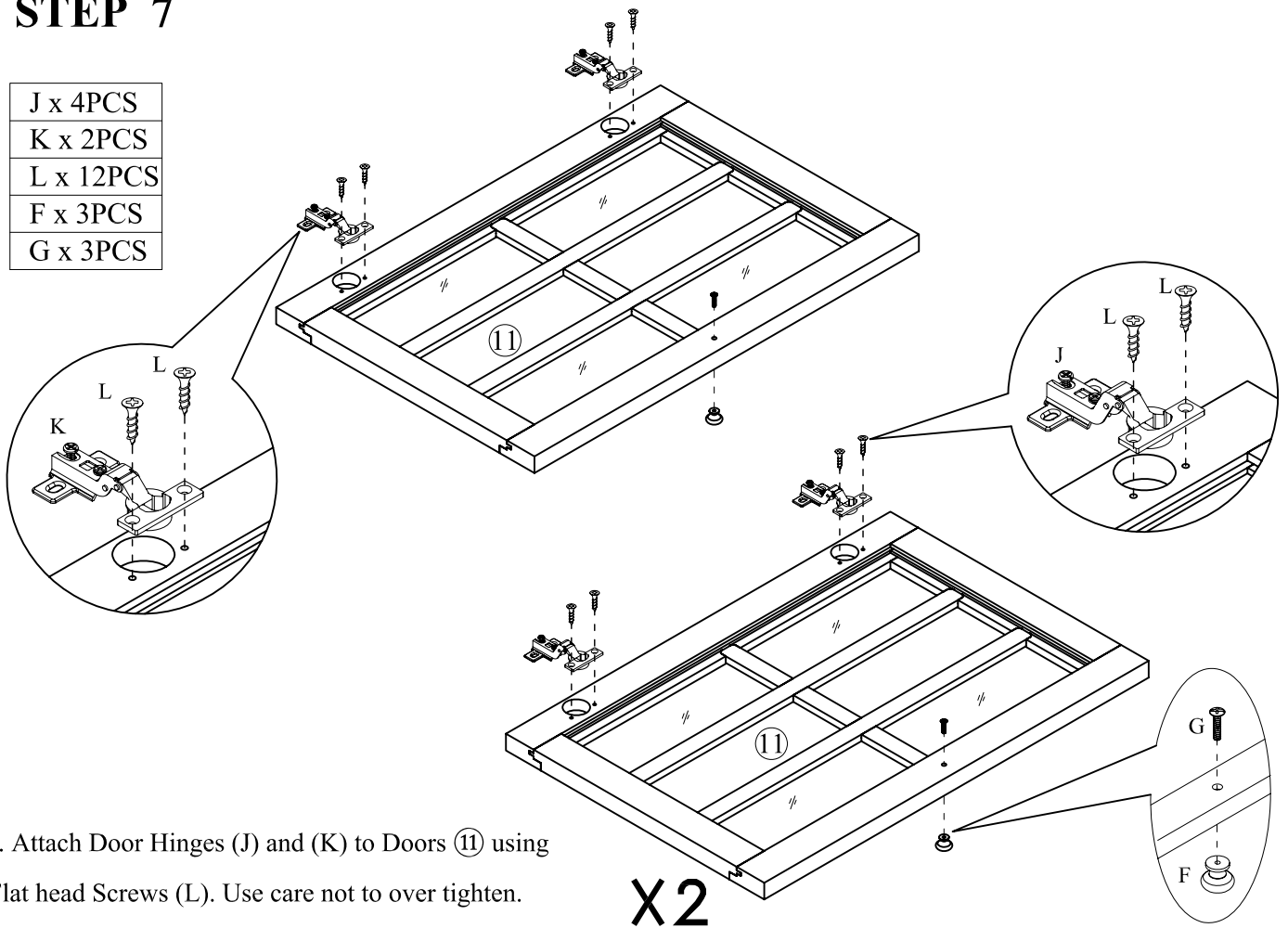

1. Attach Door Hinges (J) and (K) to Doors (11) using Flat head Screws (L). Use care not to over tighten.
2. Attach Knobs (F) to Doors using Knob Screws (G).

STEP 8

L x 12PCS

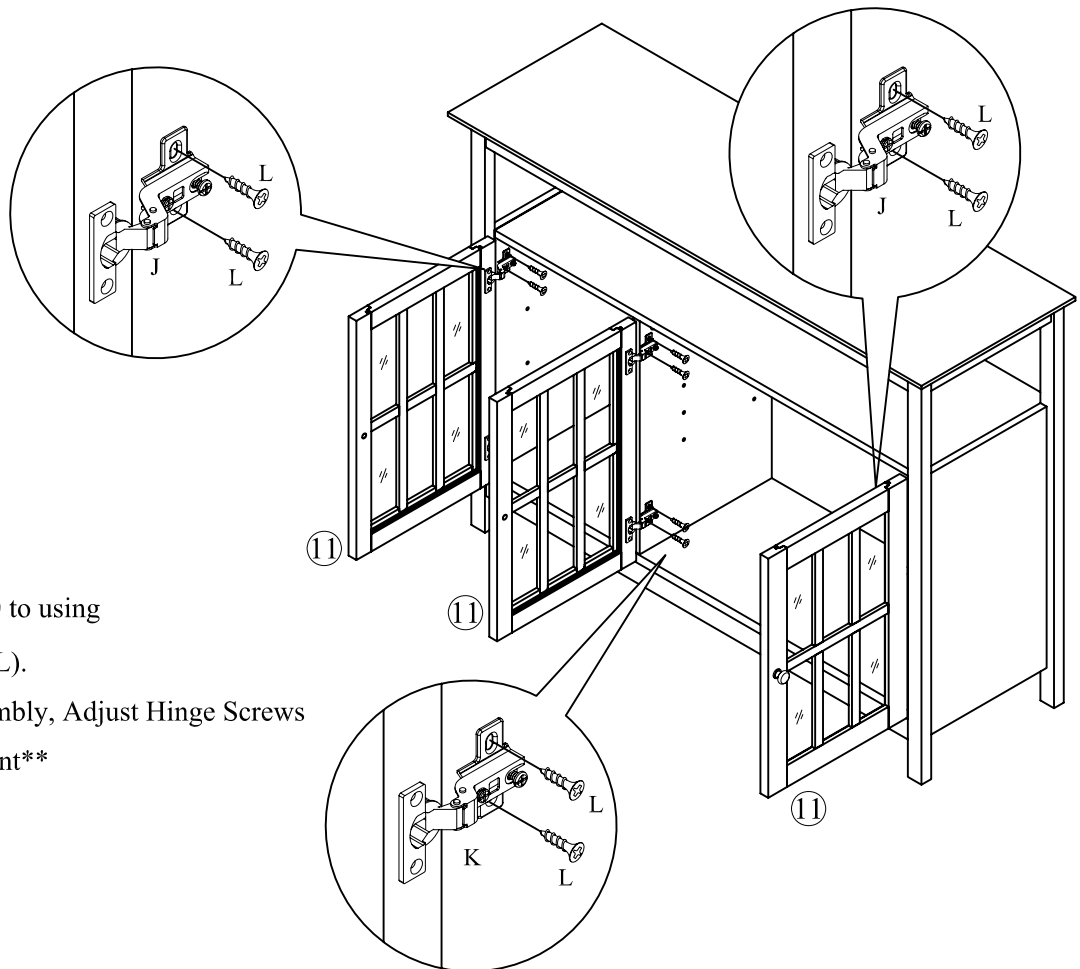

1. Attach Doors (11) to using Flat head Screws (L).
- **After Final assembly, Adjust Hinge Screws for Better Alignment****

STEP 9

H x 28PCS
M x 1PCS

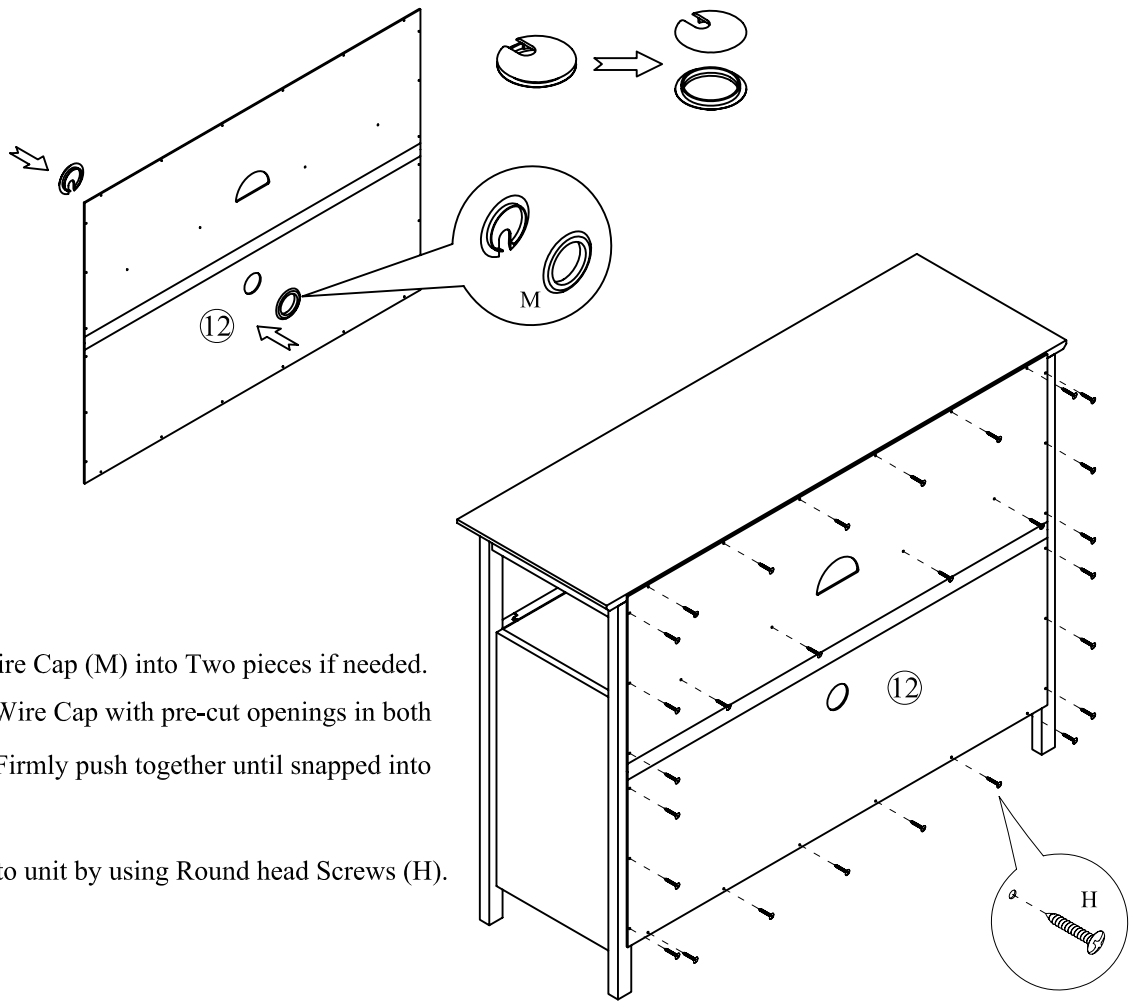

1. Carefully pull apart Wire Cap (M) into Two pieces if needed.
2. Align each half of the Wire Cap with pre-cut openings in both sides of Back Panel (12). Firmly push together until snapped into place.
3. Attach Back Panel (12) to unit by using Round head Screws (H).

STEP 10

I x 8PCS

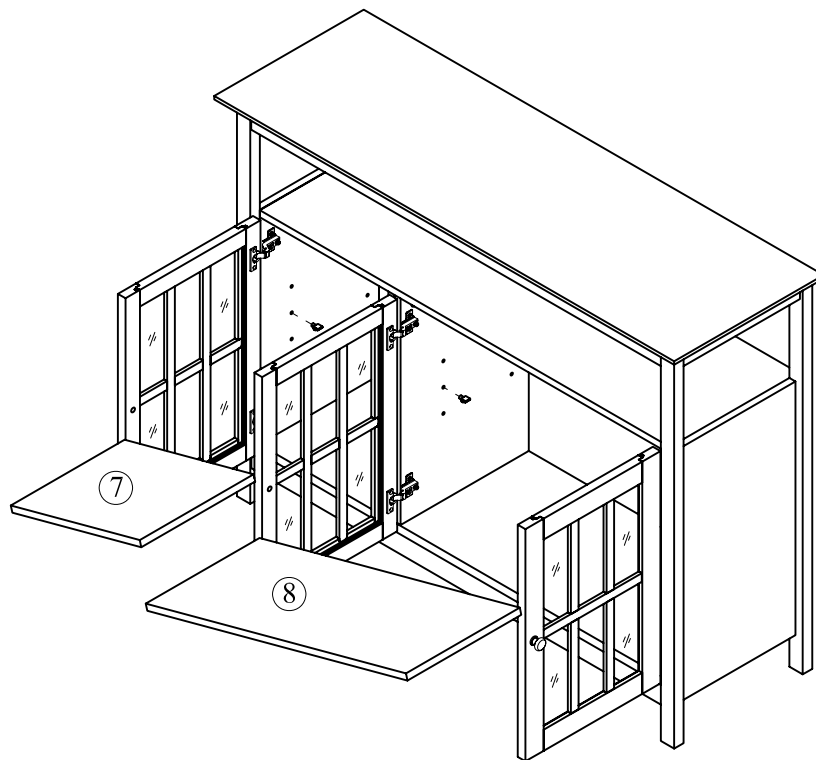

1. Insert Shelf Supports (I) into desired position holes in side panels and Divider.
2. On a slight angle, carefully slide Adjustable Shelves (7) and (8) into unit and on top of shelf Supports (I).

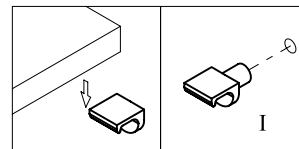

STEP 11

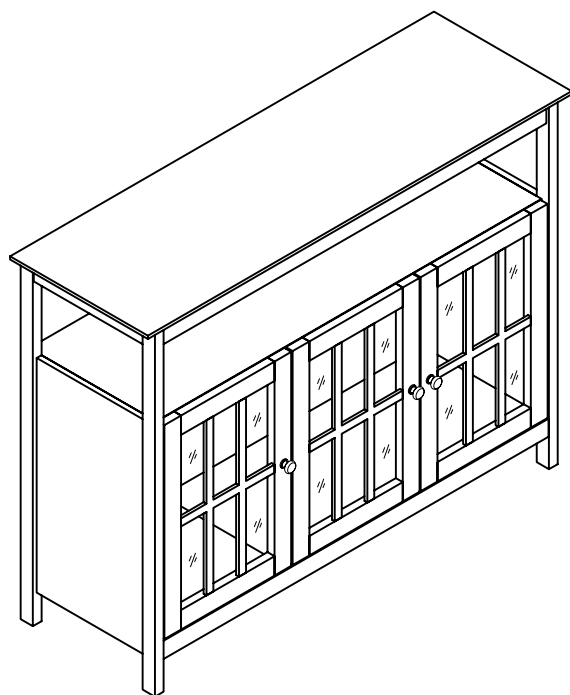

Enjoy your new piece of Quality Furniture!