

CAL KING STORAGE BED

ASSEMBLY INSTRUCTIONS

BOX #1

A. HEADBOARD 1 PC

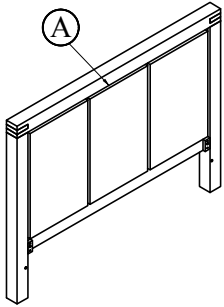

BOX #2

B. FOOTBOARD 1 PC

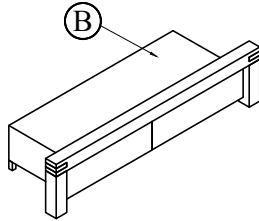

BOX #3

C. SIDERAILS 2 PCS
D. CENTER SUPPORT 1 PC
E. LEG SUPPORTS 2 PCS

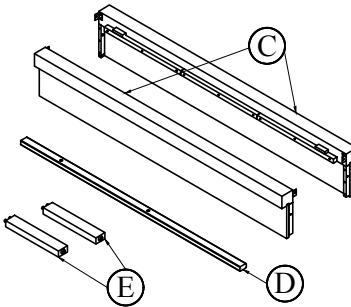

BOX #4

F. SLAT ROLL 1 SET

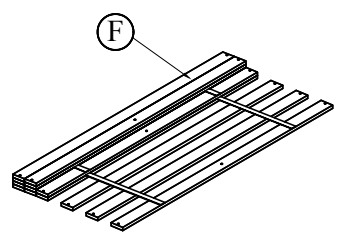

FULLY ASSEMBLED

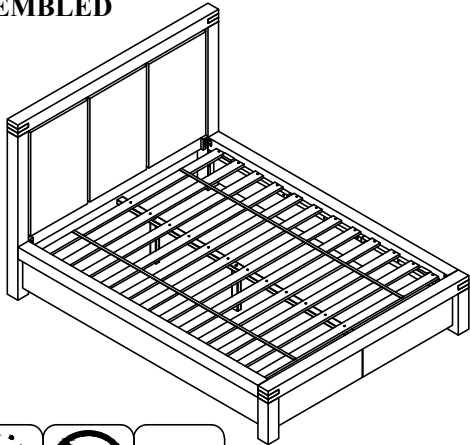

HARDWARE KIT PACKED IN BOX # 2

1	ALLEN BOLT (8x20mm)		4 PCS
2	ALLEN BOLT (8x40mm)		4 PCS
3	FLAT WASHER (M8)		8 PCS
4	ALLEN SCREW (6x50mm)		2 PCS
5	ALLEN KEY		1 PC
6	WOOD SCREW (4x25mm)		39 PCS



STEP 1

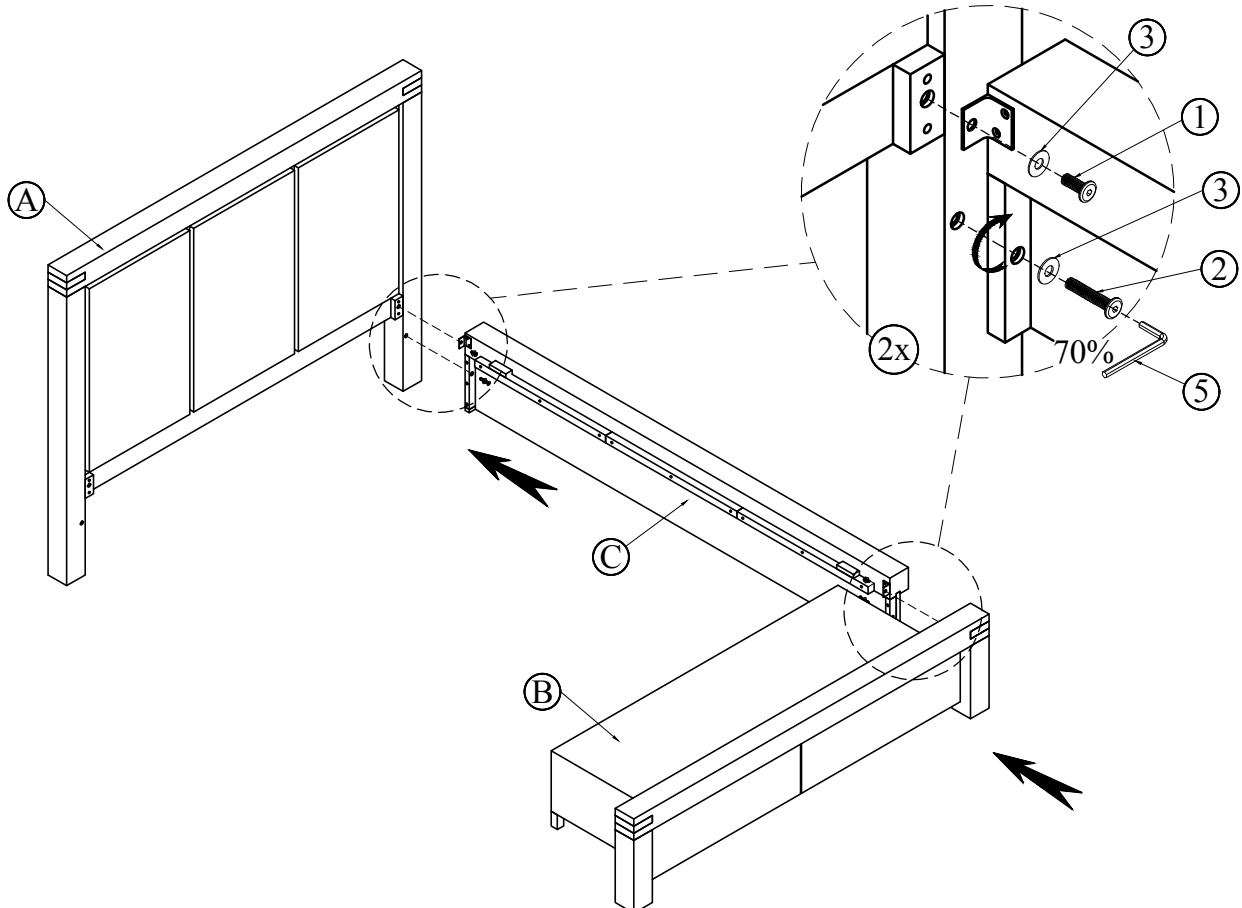

CAL KING STORAGE BED

ASSEMBLY INSTRUCTIONS

STEP 2

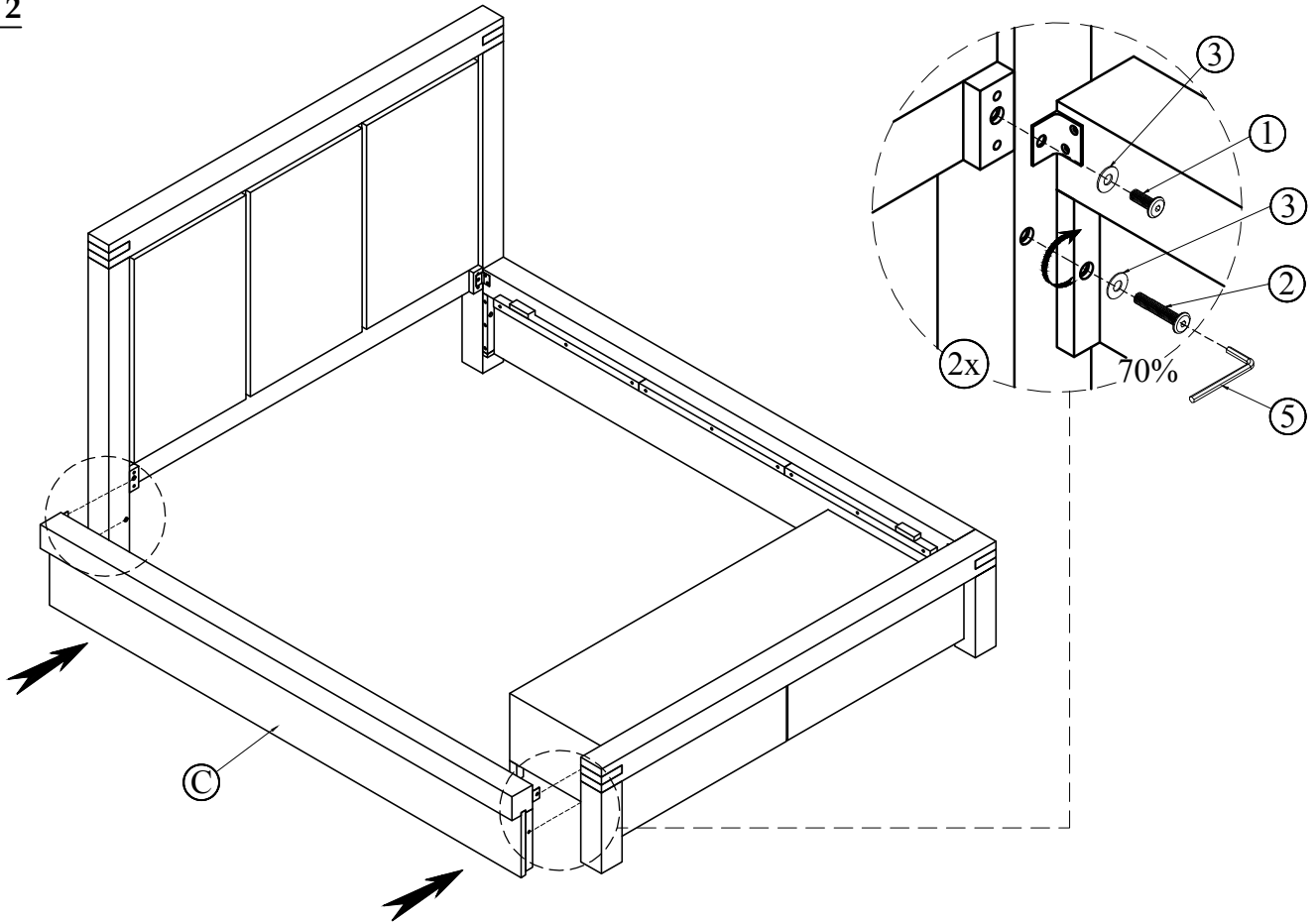

STEP 3

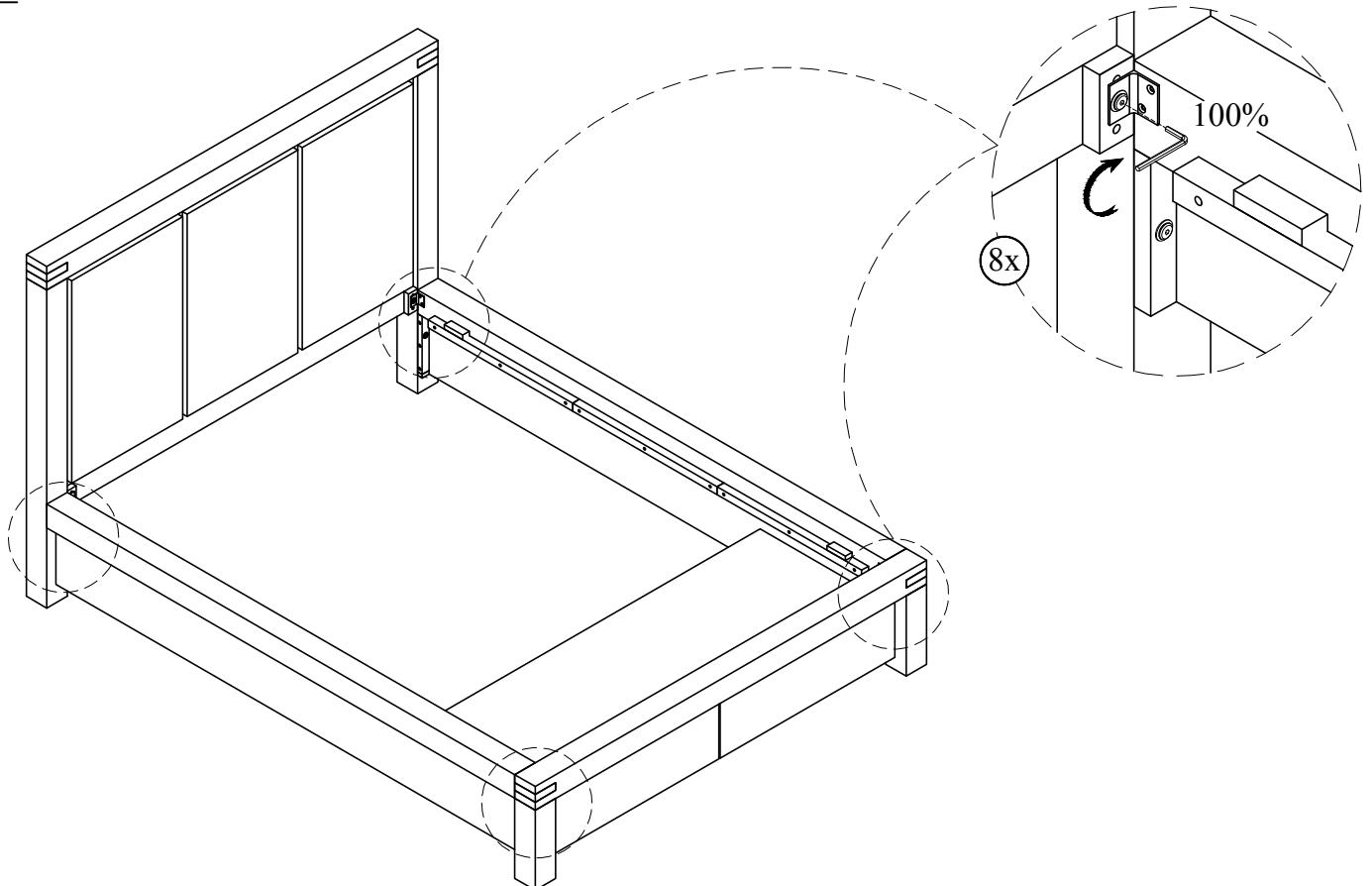

CAL KING STORAGE BED

ASSEMBLY INSTRUCTIONS

STEP 4

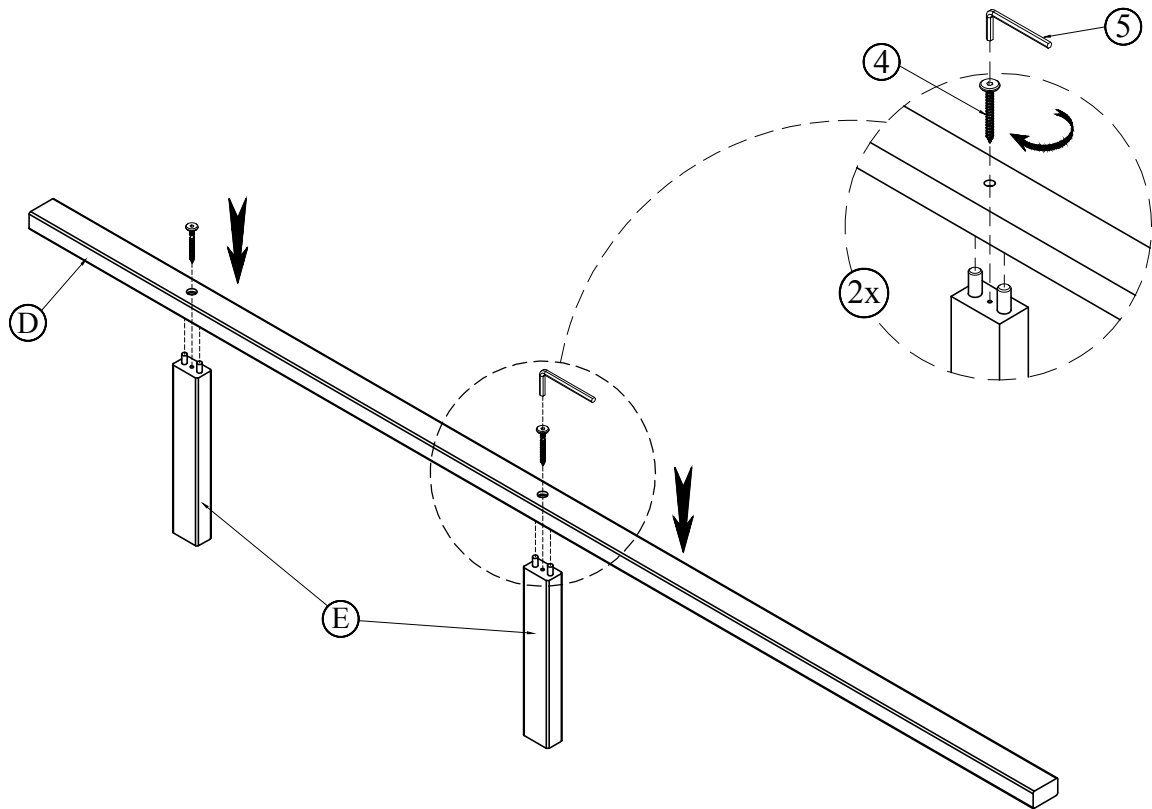

STEP 5

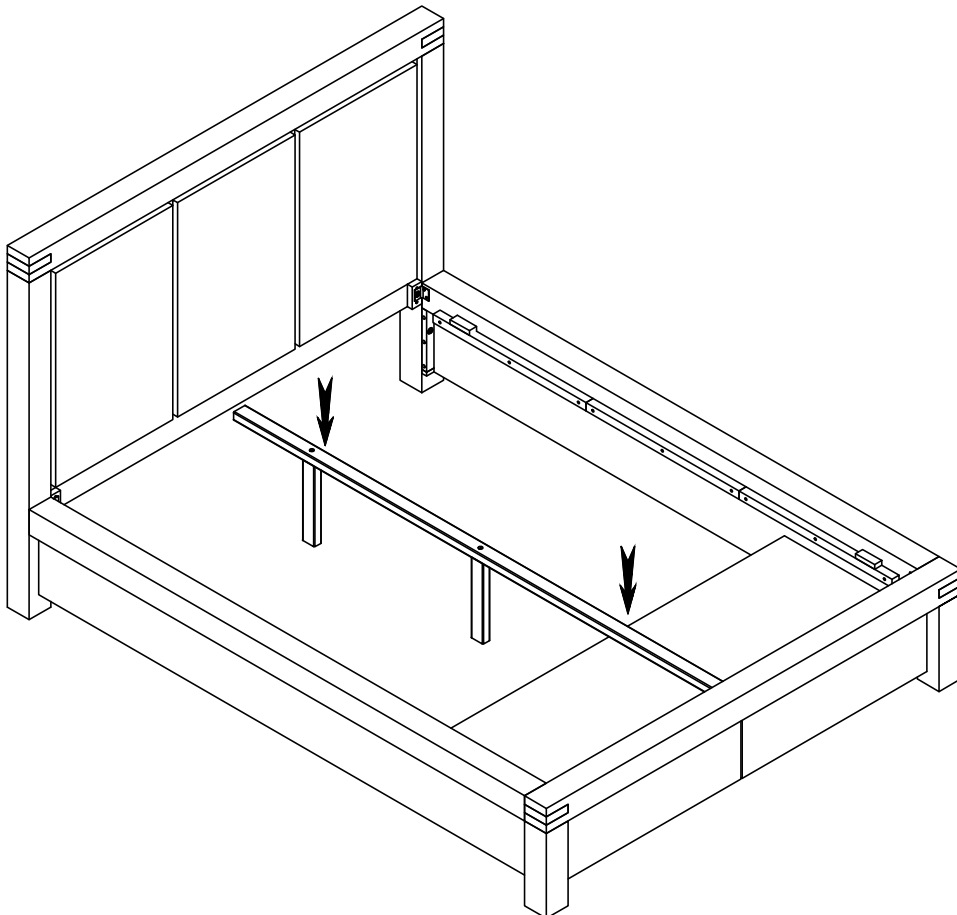

CAL KING STORAGE BED

ASSEMBLY INSTRUCTIONS

STEP 6

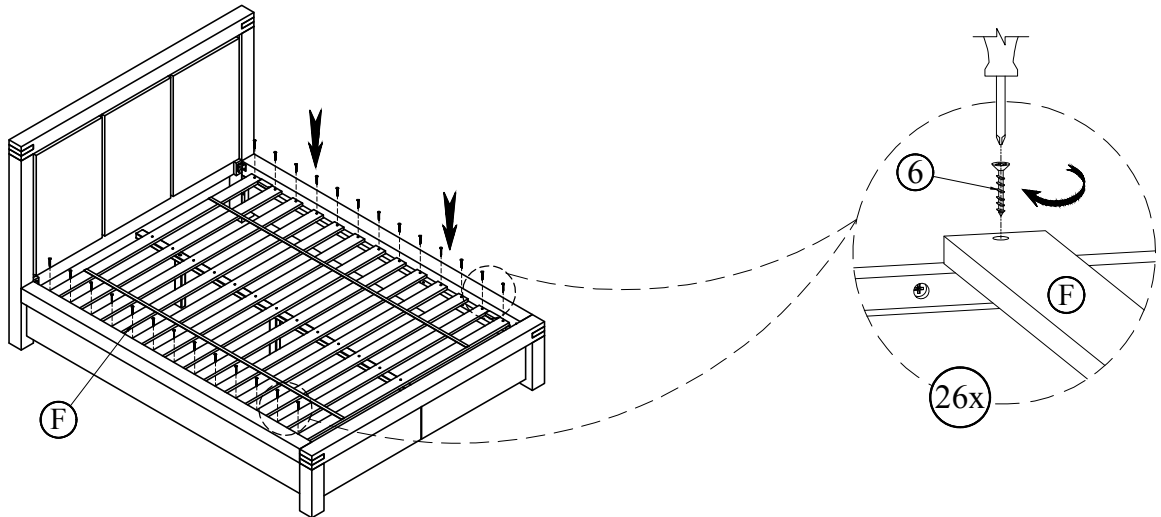

STEP 7

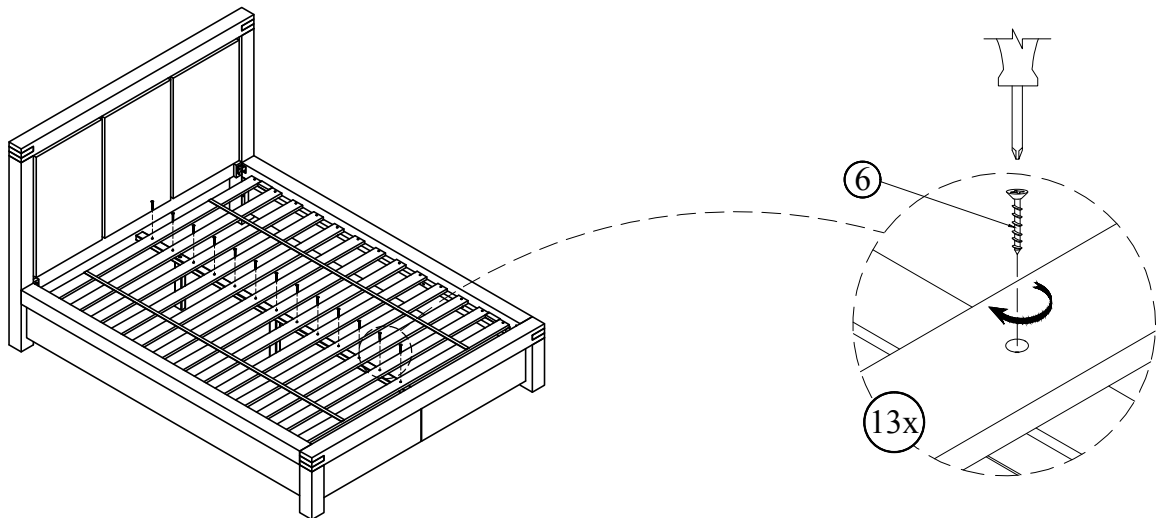

STEP 8

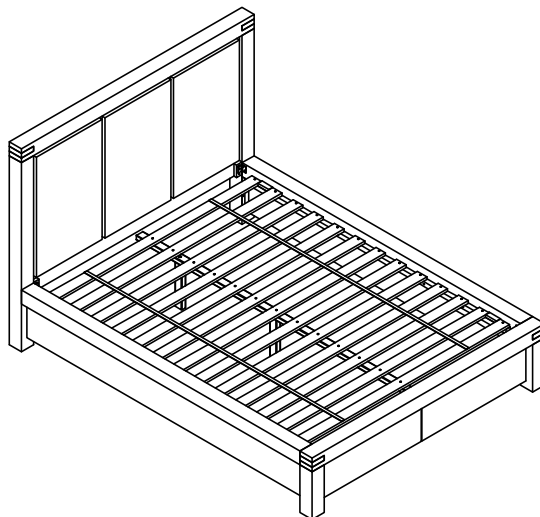

ASSEMBLY COMPLETE

INSTRUCTIONS FOR ADJUSTING LEVELERS:

Position the bed in your space and locate the leveler under each leg support (E).

Turn the leveler counter-clockwise to extend and clockwise to retract it.

Adjust each leveler until each leg support is applying equal, upward pressure on the center slat.

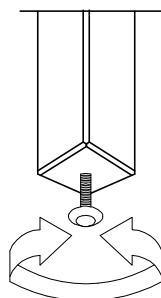

MAINTENANCE INSTRUCTIONS:

- Periodically check all fittings and tighten if necessary, as they can loosen over time.
- Always remove box spring and mattress before moving the bed.
- Lift the bed when moving it. Dragging the bed can damage the center support.
- Readjust levelers after moving the bed.