

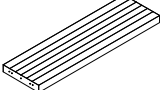





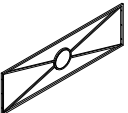

ASSEMBLY INSTRUCTION

Thank you for purchasing this quality product. Be sure to check all packing material carefully for small parts which may have come loose inside the carton during shipment. Separate, identify and count all parts and metal hardware. Compare with parts list to be sure all parts are present. If any part(s) are missing or damaged, please contact your local furniture dealer. For efficient and speedy service, please indicate the model number and code letter of part(s) needed.

*** Do not fully tighten screws until fully assembled ***

No.	COMPONENT LIST		Q'ty	No.	COMPONENT LIST		Q'ty
Ⓐ		TABLE TOP	1pc	Ⓑ		LEGS	2pcs
Ⓒ		METAL FRAME	1pc				
No.	HARDWARE LIST		Q'ty	No.	HARDWARE LIST		Q'ty
①		Bolts 5/16"x2"	6	②		Spring washers 5/16"x 1/2"	6
③		Flat washers Ø1/4"x 3/4"	6	④		Bolts 1/4"x1.2"	6
⑤		Wood Dowel	4	⑥		Allen key K4	1

Take the Wood Dowel (5) Put into Leg(B) . Then Connect Table Top(A) with Bolts (1), Spring Washer (2) and Flat washer (3) (2 side) . And connect Metal frame (C) with Leg (B) with bolt (4). Then use Allen key (6) tighten all bolts.

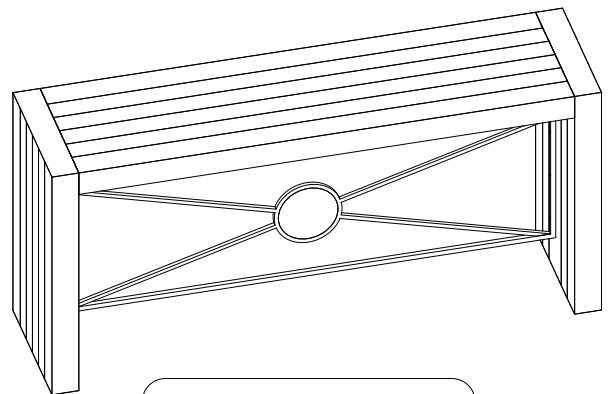
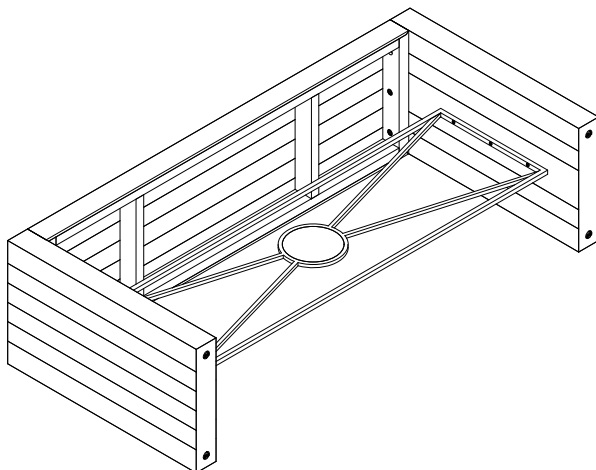
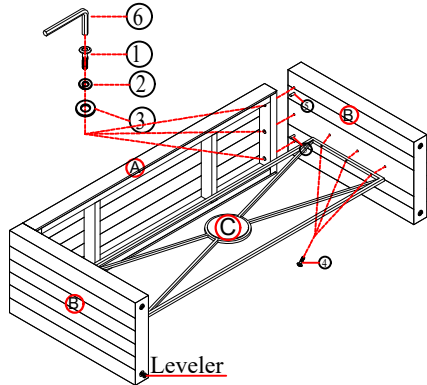

FINISH .
THANK YOU !