











# Assembly Instruction

## ⚠ WARNING:

- Read all instructions carefully and completely before assembly and use.
- Retain for future reference.
- DO NOT use power tools.
- DO NOT over-tighten hardware.
- Periodically check all hardware and re-tighten as necessary.
- DO NOT use product if any component becomes damaged.
- For residential (non-commercial) use only.
- DO NOT sit or stand on product. Use only for intended purpose.
- DO NOT exceed 80lbs for the tabletop and 30lbs for the shelf, evenly distributed.

## Parts List

Check all parts before assembly

<p>A. <u>Tabletop</u></p>  <p style="text-align: right;">*1</p>	<p>B. <u>Body</u></p>  <p style="text-align: right;">*1</p>	<p>C. <u>Shelf</u></p>  <p style="text-align: right;">*1</p>	<p>D. <u>Back panel</u></p>  <p style="text-align: right;">*1</p>
<p>H1. <u>Hex bolt</u></p>  <p style="text-align: right;">*4(+1 extra)</p>	<p>H2. <u>Washer</u></p>  <p style="text-align: right;">*4</p>	<p>H3. <u>Foot pad</u></p>  <p style="text-align: right;">*4</p>	<p>H4. <u>Alley key</u></p>  <p style="text-align: right;">*8</p>
<p>H5. <u>Metal pin</u></p>  <p style="text-align: right;">*2</p>	<p>H6. <u>Shelf pin</u></p>  <p style="text-align: right;">*4</p>		

Step 1: Unfold the left panel and right panel from Body (B) as below. Insert the Foot pad (H3) as below shows.

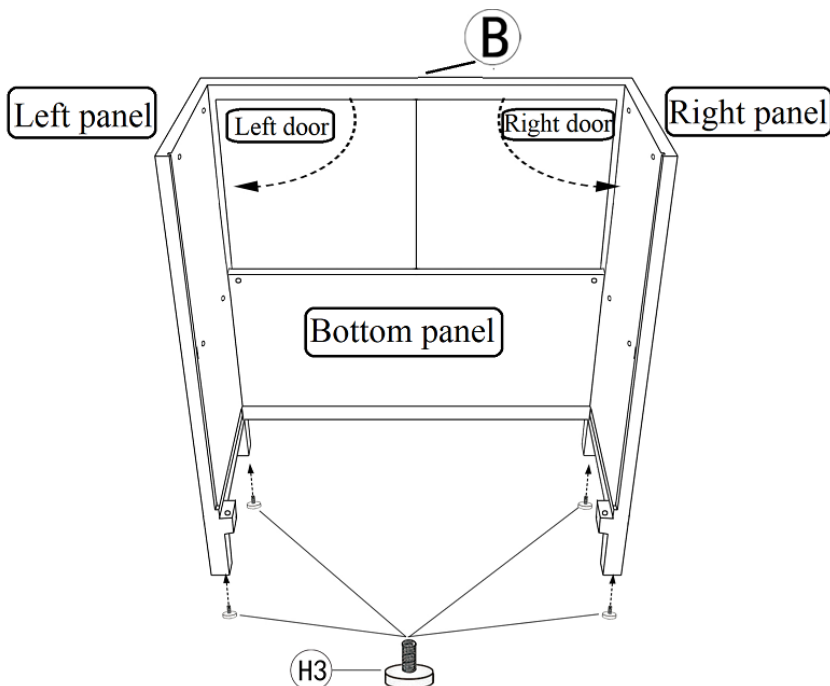

Step 2: Insert the metal pin (H5) on left&Right panel as below left photo shows. Unfold the bottom shelf from Body (B) as below. Make sure the holes on the bottom shelf to match the metal pins (H5) well. Insert the Shelf pins (H6) to the on left&Right panel as below right photo shows.

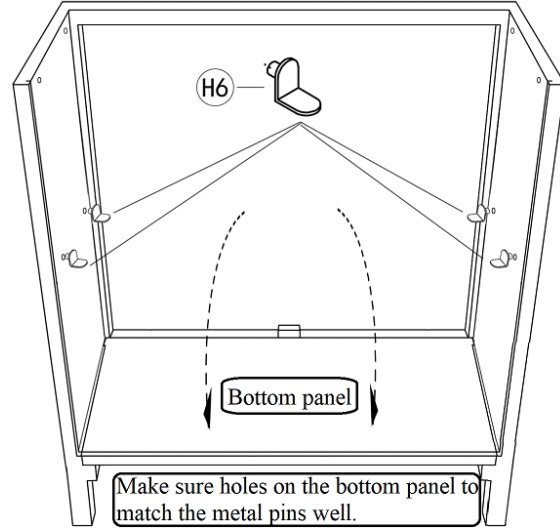
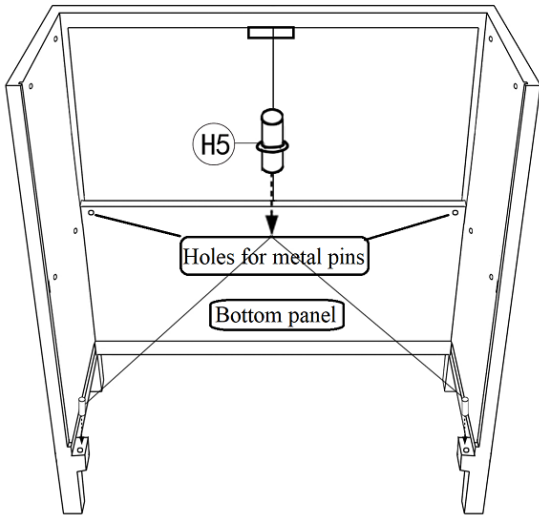

Step 3: Place the Shelf (C) inside as shown in picture below. Insert Attach Back panel (D) as shown in picture below. Ensure the Back panel (D) with the groove on Left&Right panel (B).

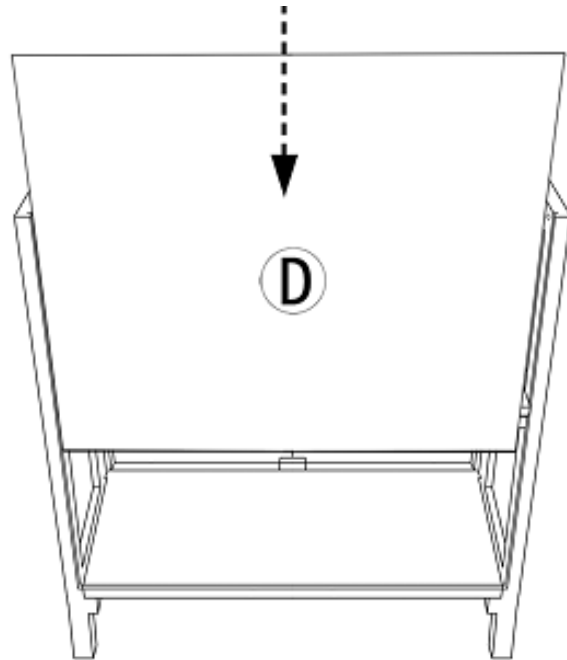
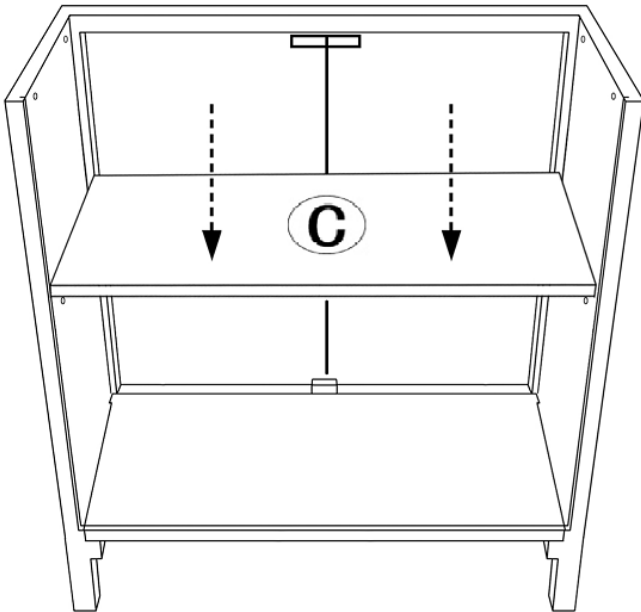

Step 4: Before place the Tabletop (A), please note that the side with a Groove aligned with the Back panel (D) as shown in below.

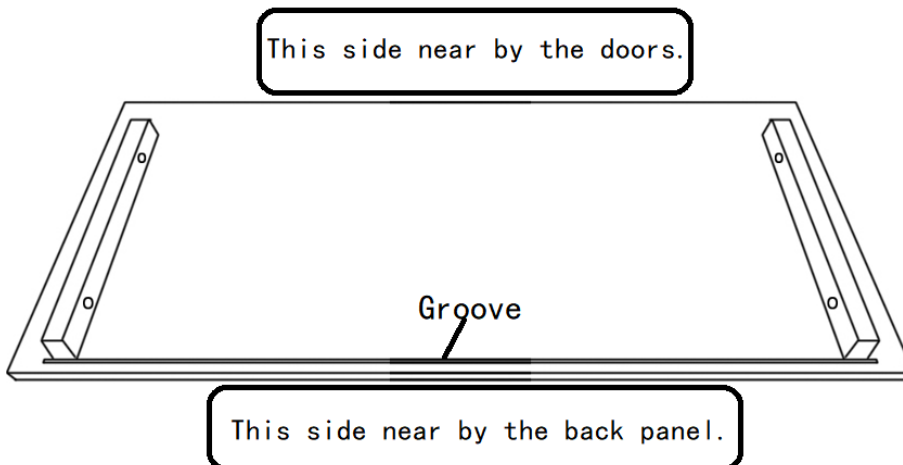

Step 5: Open the doors, attach the Tabletop (A) to the Body (B) with Hex bolts (H1) and Washers (H2) by Allen key (H5) as shown in picture below.

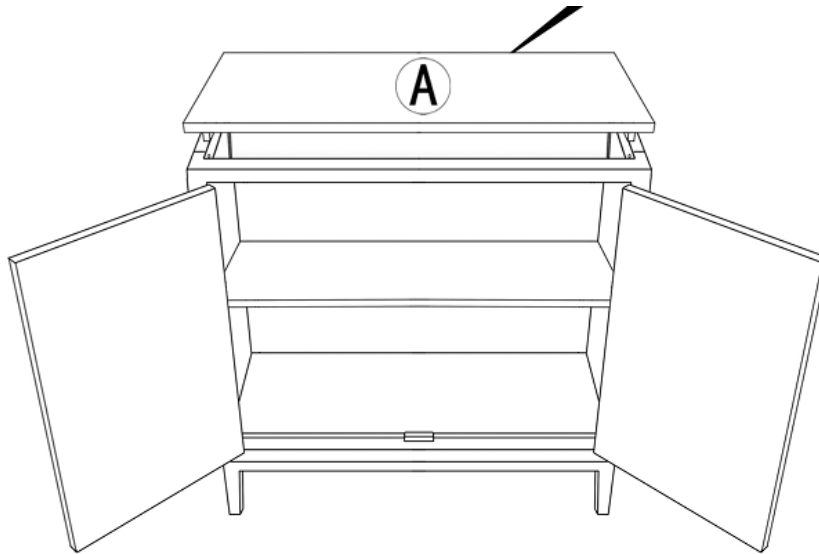
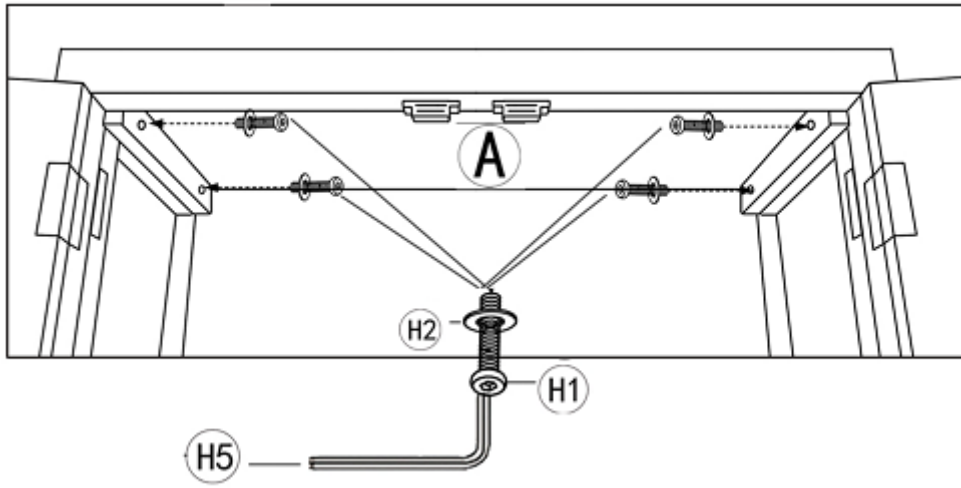

Assembly finished.



Notice:

If you have any questions about your purchase or any other product for sale, please contact [Service@jimsidea.com](mailto:Service@jimsidea.com) with your order ID, our customer service representatives are available to help.