

# Assembly Instructions

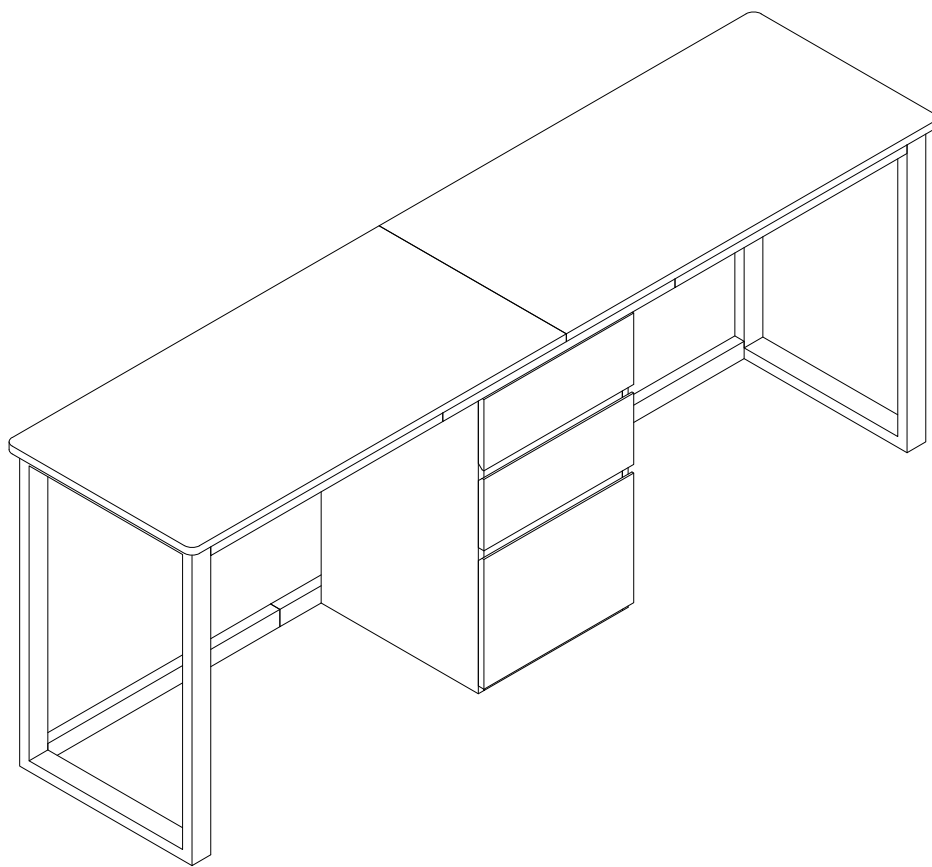

---

**Double Desk**

Model No.  
**HOGA-F2436**

---

# Contact Us

## We're here to help you.

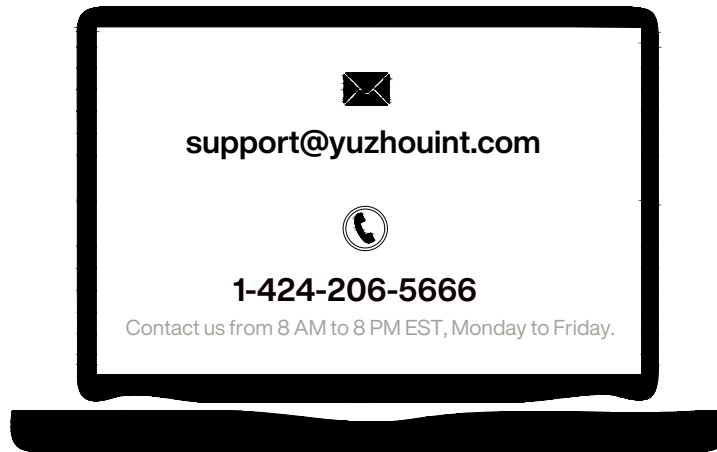

Your satisfaction is our top priority. If you encounter any issues with this product, such as missing or damaged parts, we're here to help. Please retain the original packaging and take photos of the packaging and the product, then contact us as soon as possible.

### Warm Tips

1. Carefully read these instructions and keep them for future reference.
2. Check the parts list and confirm everything's there before starting assembly.
3. When assembling, put all parts on a soft, smooth surface like a carpet to avoid scratches.
4. Don't fully tighten screws until all parts are confirmed in place to avoid misalignment.

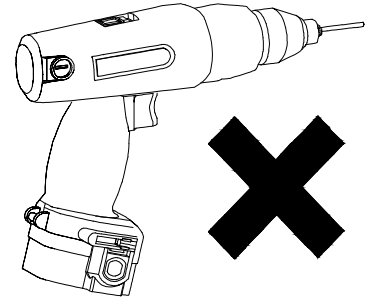
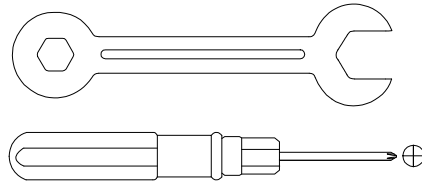
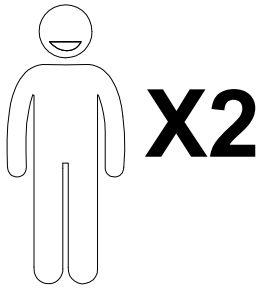

We recommend using hand tools for assembly.

If an electric screwdriver is used, reduce power and torque to avoid damage to the product.

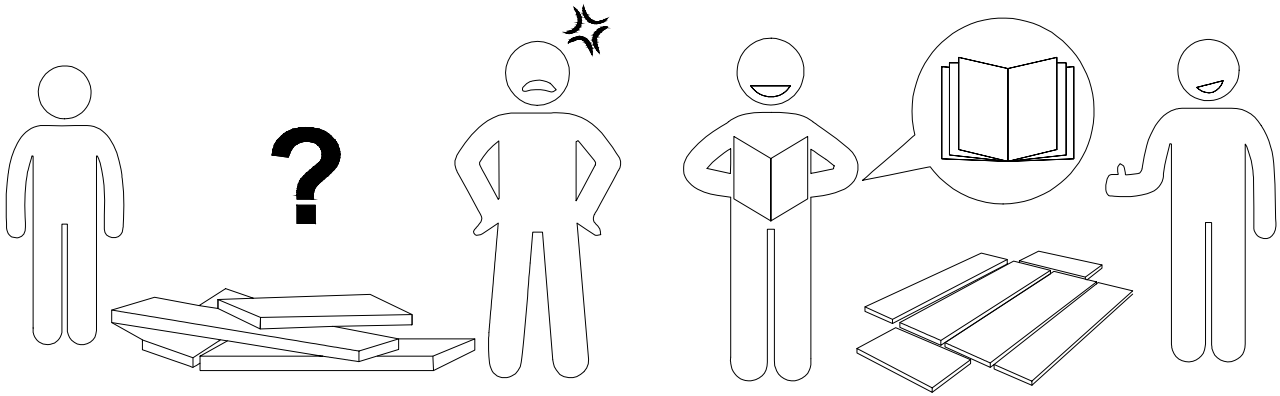

## AVOID SCRATCHES

In order to avoid scratching, this furniture should be assembled on a soft surface, such as a rug.

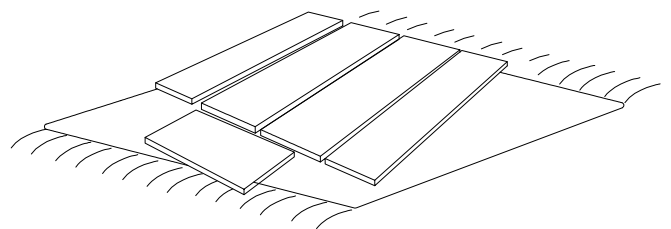
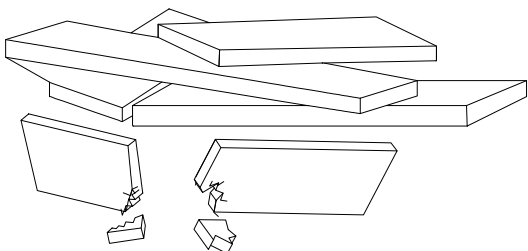

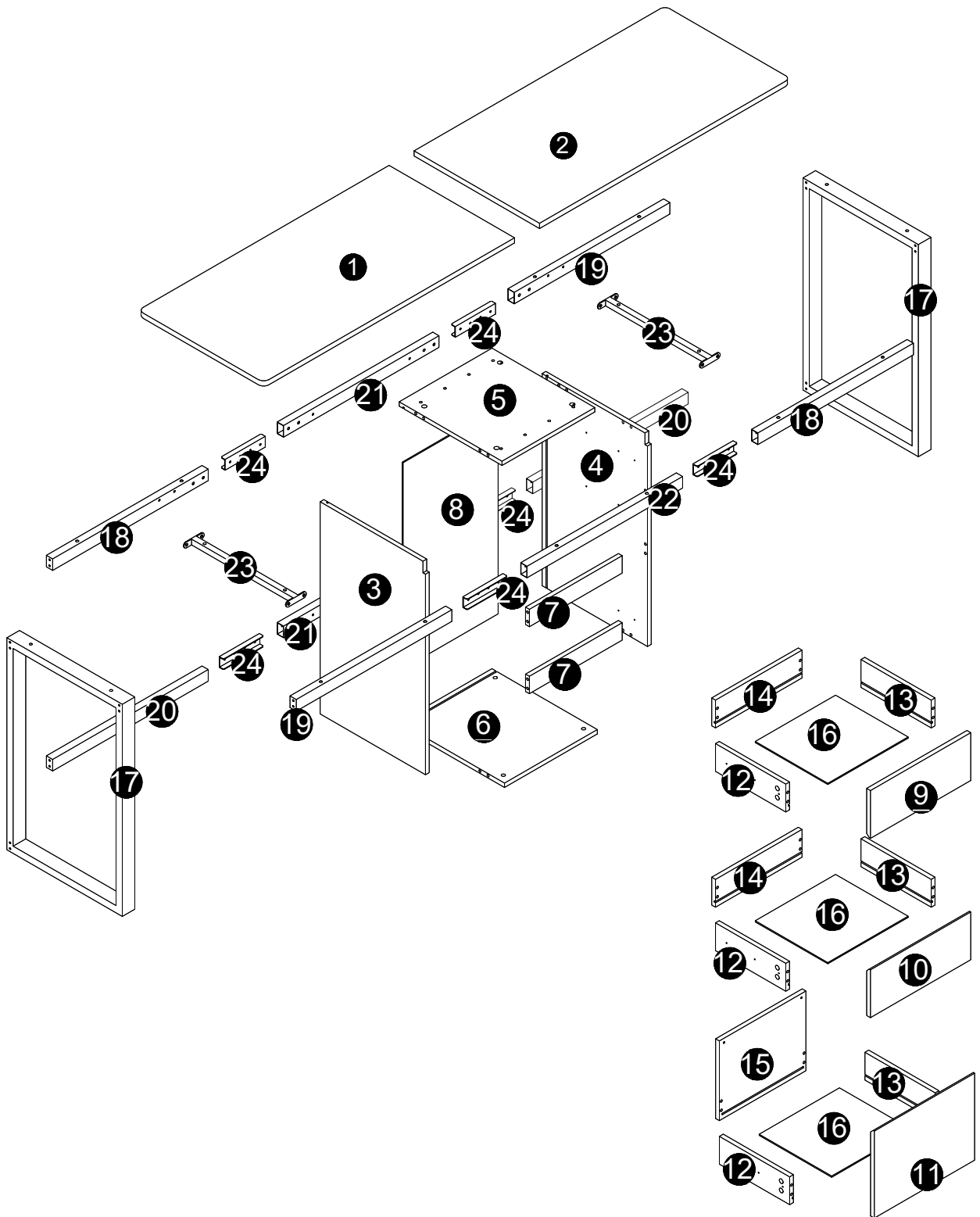







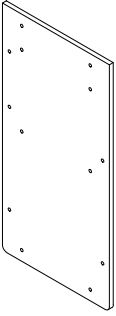
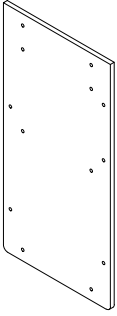
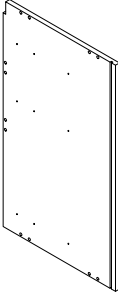
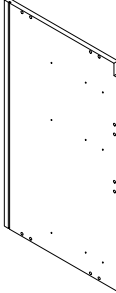
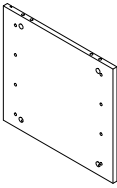
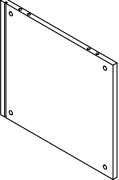
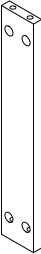

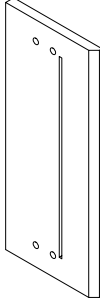
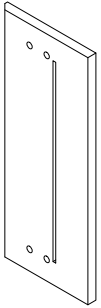
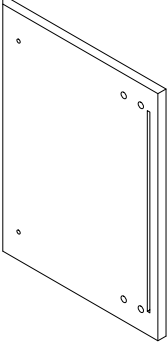
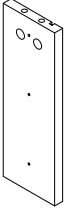
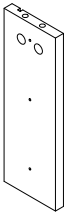
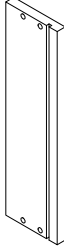
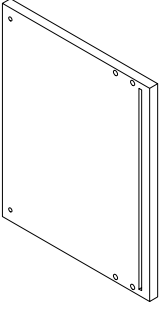
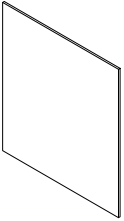
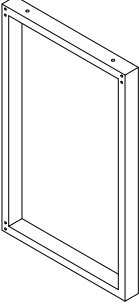

**⚠ Caution**

Make sure all parts are included. Most board parts are labeled or stamped on the raw edge. Contact us for a free replacement if you encounter any damaged or missing parts.

# Parts List

<p><b>1</b></p>  <p>1pc</p>	<p><b>2</b></p>  <p>1pc</p>	<p><b>3</b></p>  <p>1pc</p>	<p><b>4</b></p>  <p>1pc</p>	<p><b>5</b></p>  <p>1pc</p>
<p><b>6</b></p>  <p>1pc</p>	<p><b>7</b></p>  <p>2 pcs</p>	<p><b>8</b></p>  <p>1pc</p>	<p><b>9</b></p>  <p>1pc</p>	<p><b>10</b></p>  <p>1pc</p>
<p><b>11</b></p>  <p>1pc</p>	<p><b>12</b></p>  <p>3 pcs</p>	<p><b>13</b></p>  <p>3 pcs</p>	<p><b>14</b></p>  <p>2 pcs</p>	<p><b>15</b></p>  <p>1pc</p>
<p><b>16</b></p>  <p>3 pcs</p>	<p><b>17</b></p>  <p>2 pcs</p>	<p><b>18</b></p>  <p>2 pcs</p>	<p><b>19</b></p>  <p>2 pcs</p>	<p><b>20</b></p>  <p>2 pcs</p>

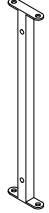

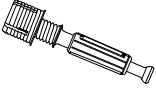
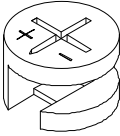
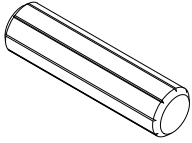
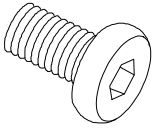
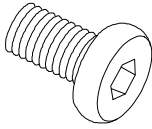
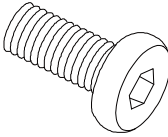
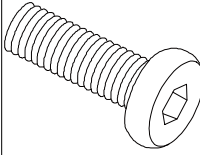

## Parts List

<b>21</b>	<b>22</b>	<b>23</b>	<b>24</b>	
				
2 pcs	1 pc	2 pcs	6 pcs	

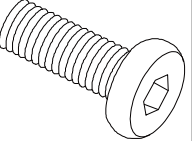
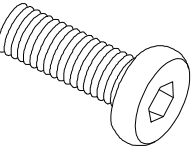
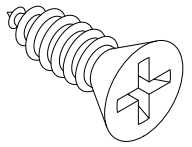
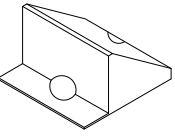
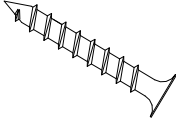
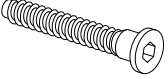
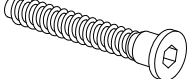
## Hardware List

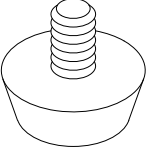
A	B	C	D	E	F	G
						
<b>Ø6x40mm</b>	<b>Ø15x12mm</b>	<b>Ø8x30mm</b>	<b>M6x12mm</b>	<b>M6x25mm</b>	<b>M6x30mm</b>	<b>M6x35mm</b>
28 pcs	28 pcs	8 pcs	32 pcs	8 pcs	4 pcs	4 pcs

H	I	J	K	L	M	N
						
<b>M6x50mm</b>	<b>M6x60mm</b>	<b>Ø3.5x14mm</b>		<b>Ø3x18mm</b>	<b>Ø5x40mm</b>	<b>Ø7x47mm</b>
10 pcs	12 pcs	36 pcs	8 pcs	8 pcs	12 pcs	4 pcs

O	P	Q	R	S		
						
<b>8 pcs</b>	<b>M4</b>	<b>M3</b>	<b>290x35mm</b>	<b>Ø5x300mm</b>		
8 pcs	1 pc	1 pc	3 sets	2 pcs		

## Installation of Cams and Pins

Step 1-2: Align the plastic part with the mounting hole and press it in. If you can't press it in, loosen the screw counter clockwise or completely remove the screw from the plastic part and try again.  
Step 3-4: After pressing the plastic part into place, use a screwdriver to tighten the screw clockwise.

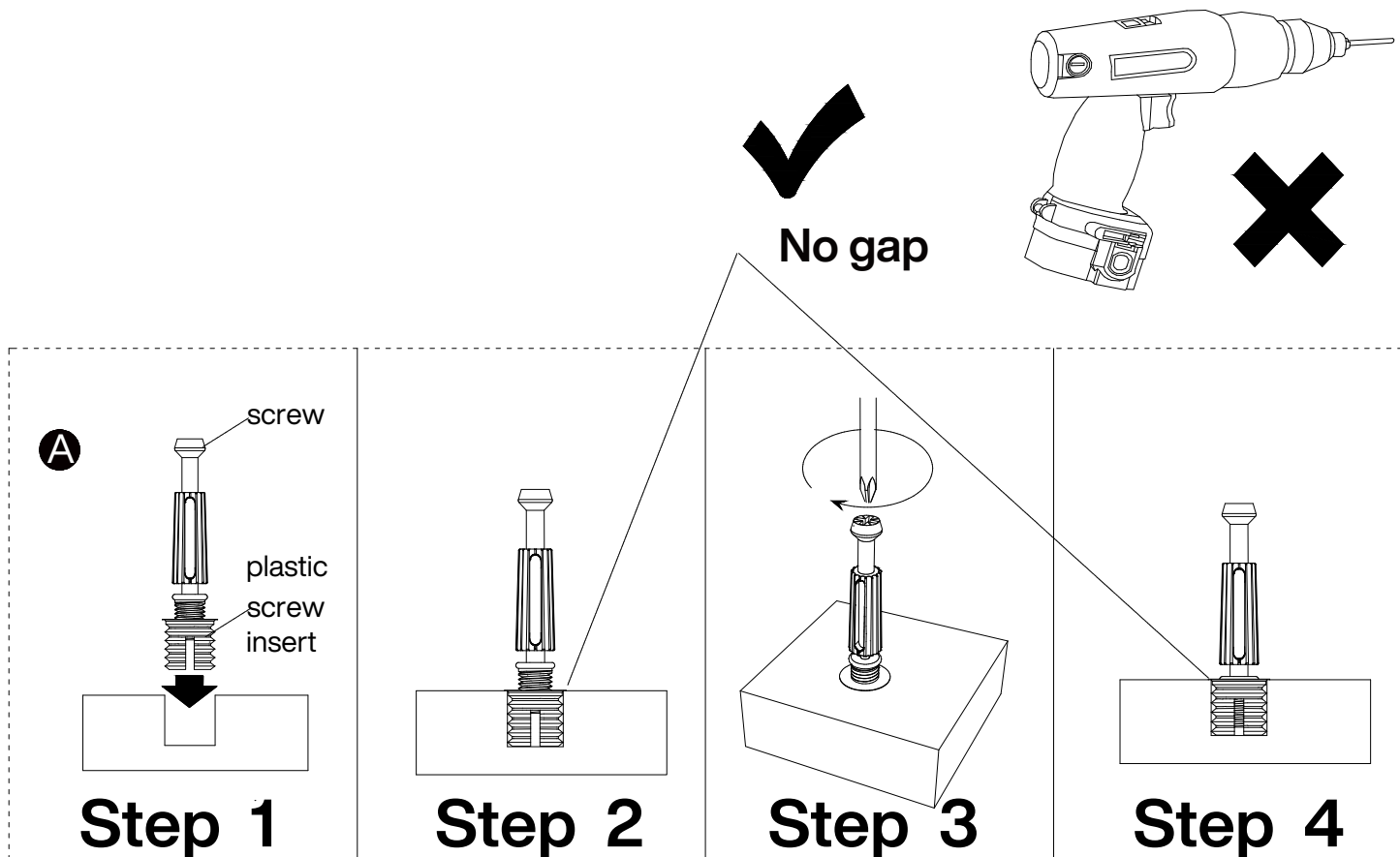

Screw the pin into the hole. Set the cams correctly by aligning the head of the cams with the lock pins. Lock the cam by turning the cam head with a screwdriver until it is tightened. Please do not use an electric screwdriver to assemble the unit.

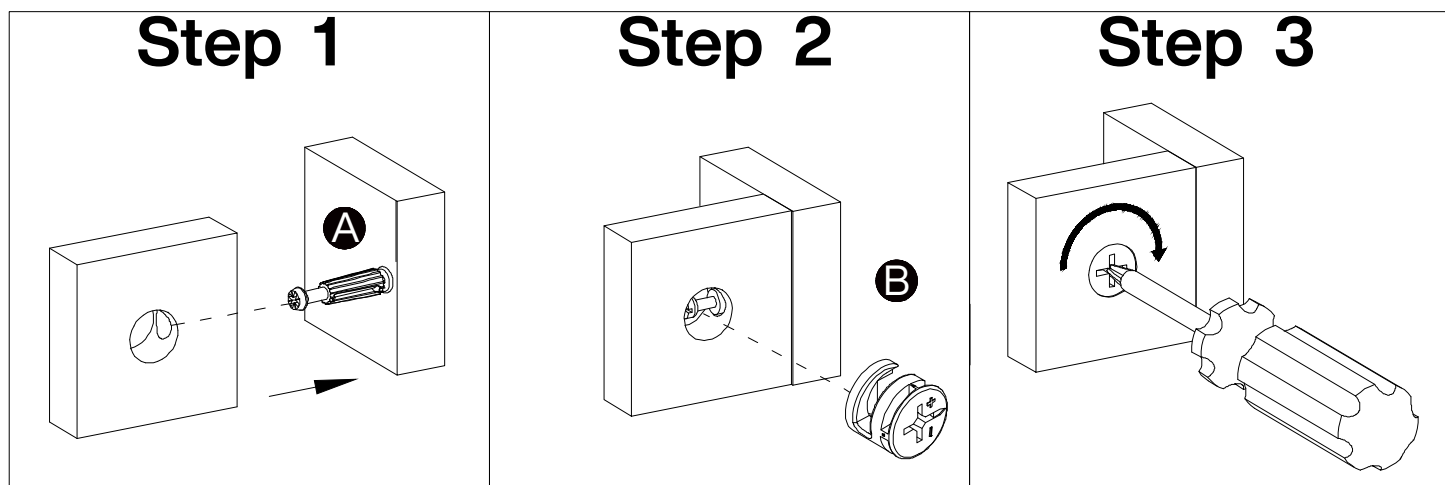

Please split component "R" into "R-1" and "R-2" before assembling the slide and then proceed to the next step of assembly

### Step 1

Pull apart component "R" to each side, and then gently push up the lever of component "R-2"

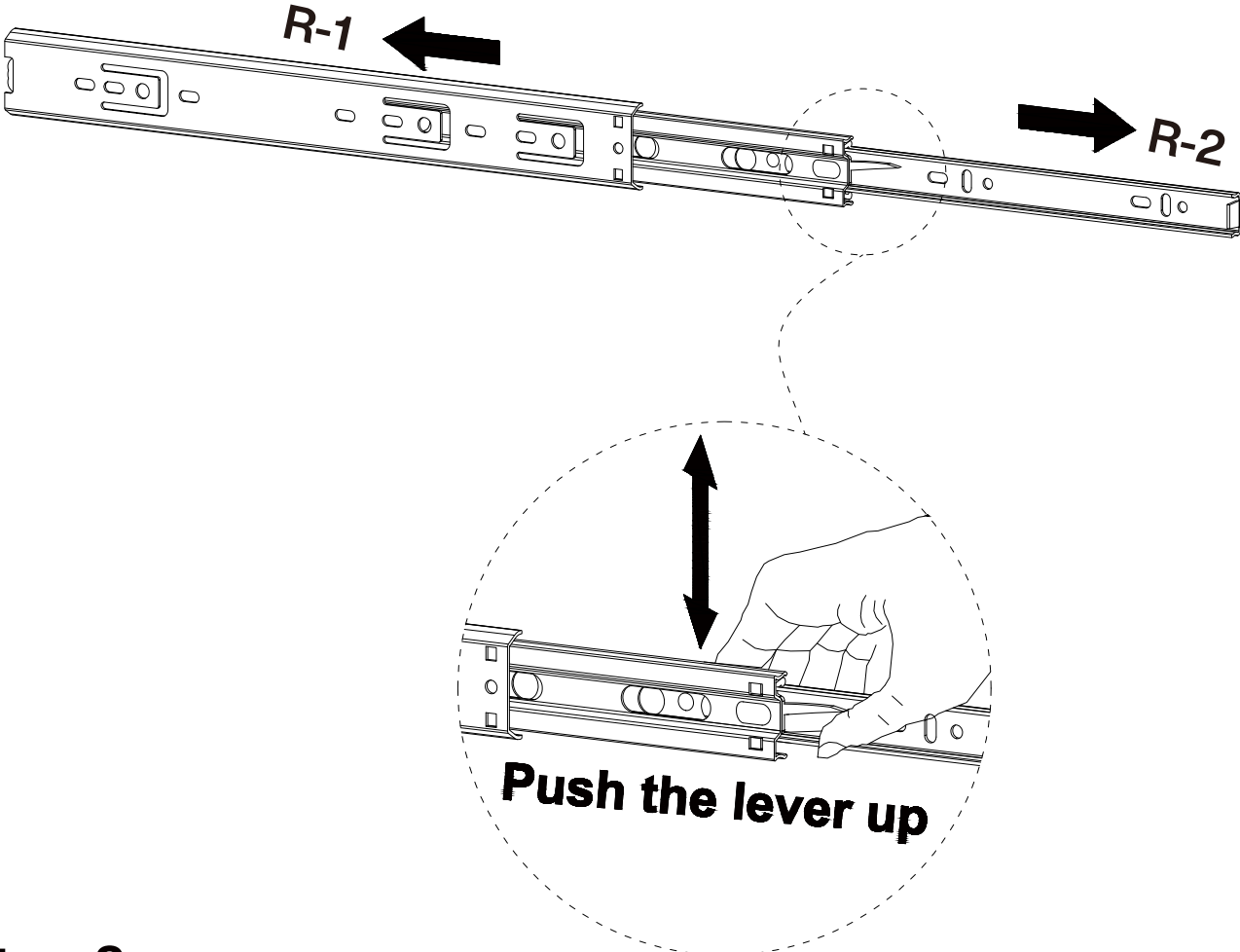

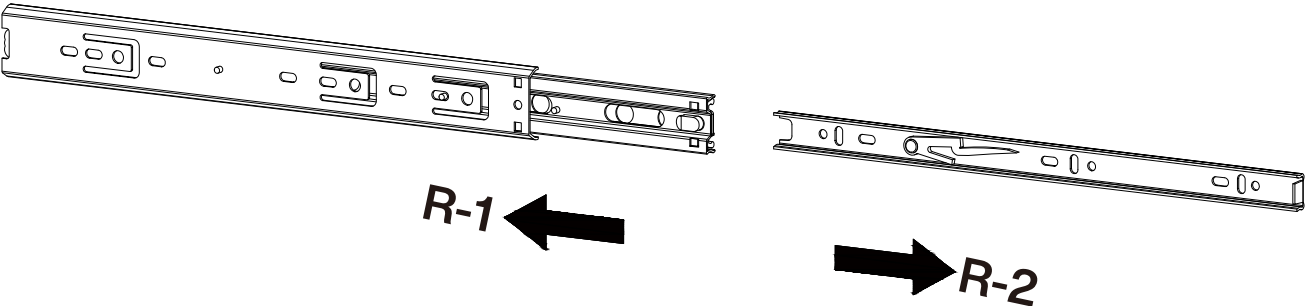

### Step 2 Split component "R-1" and "R-2"



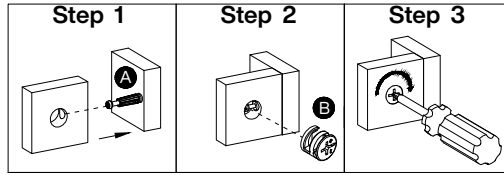

3



B	C
	
Ø15x12mm	Ø8x30mm
8 pcs	4 pcs

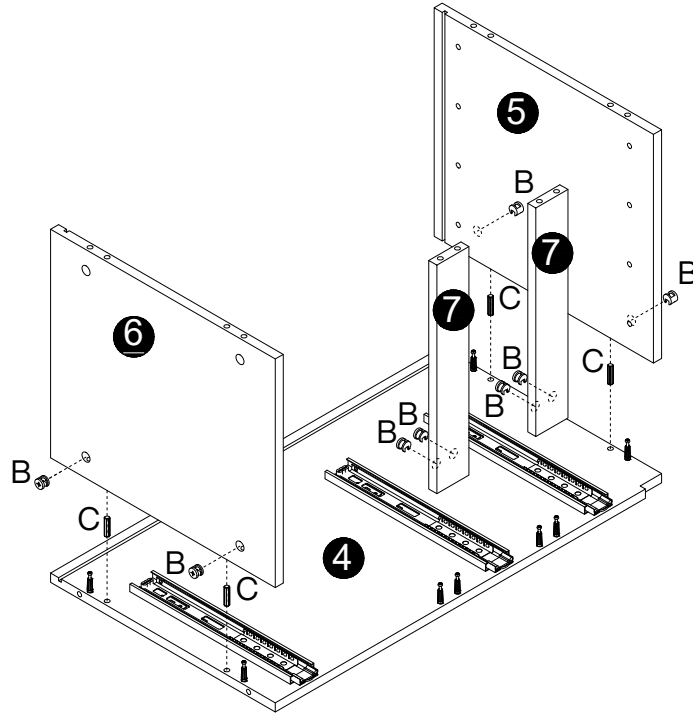

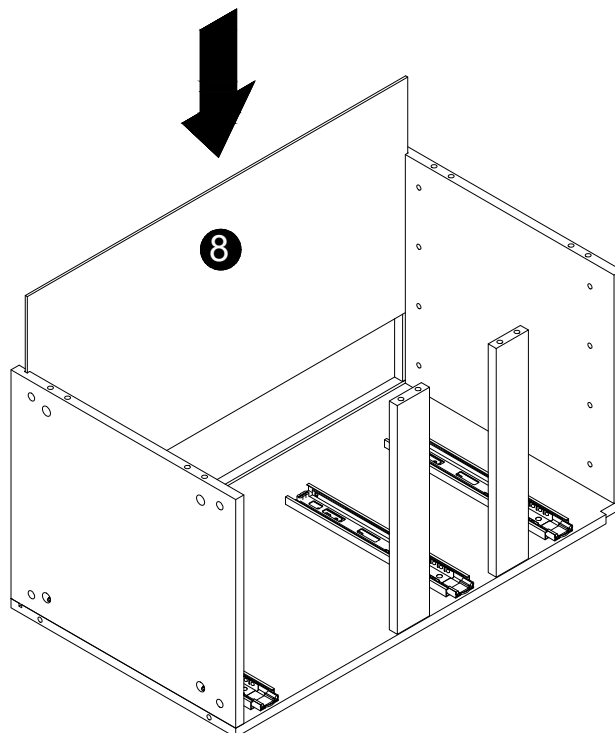

4

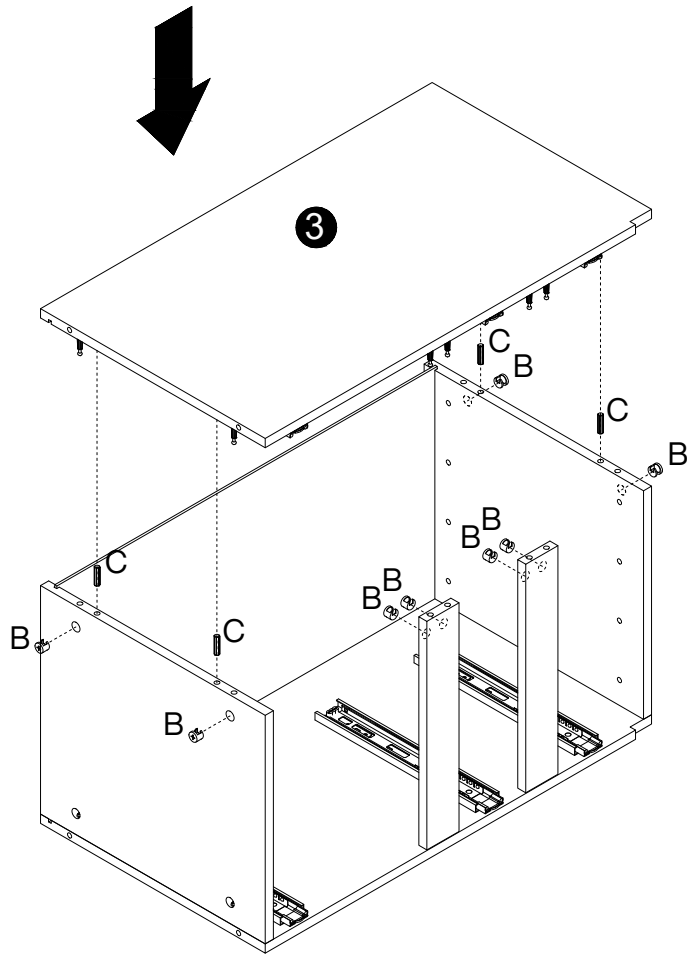

5



B	C
 Ø15x12mm	 Ø8x30mm
8 pcs	4 pcs

6

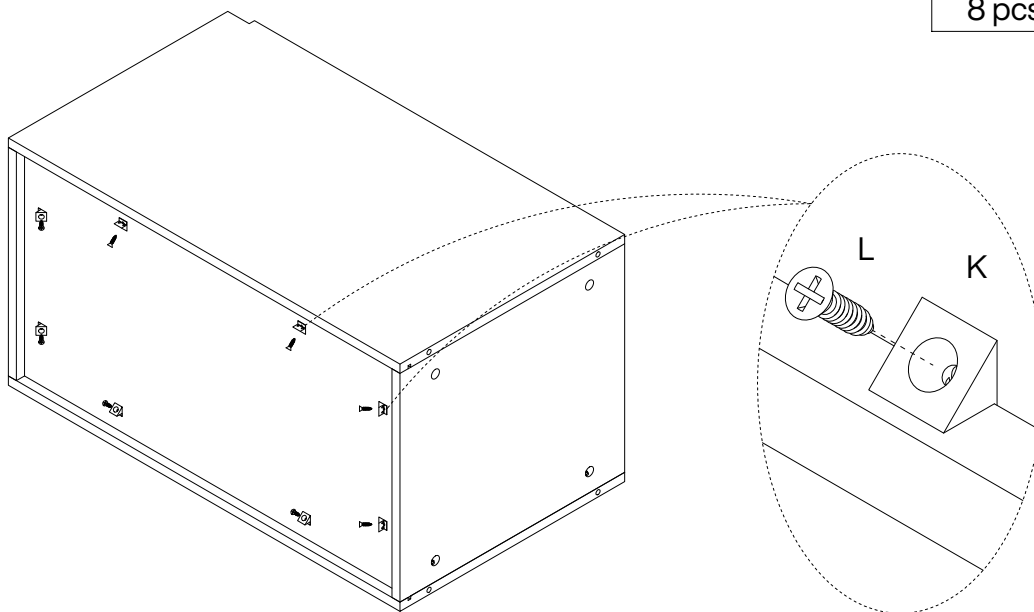

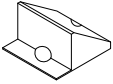
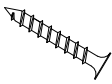
K	L
	 Ø3x18mm
8 pcs	8 pcs

7

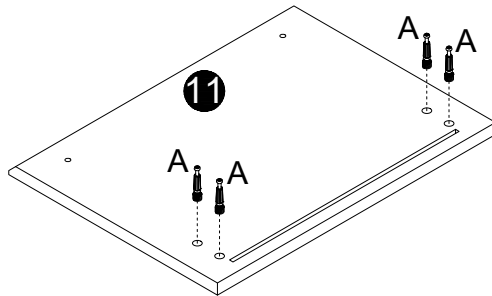
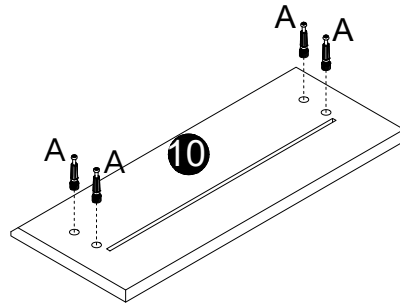
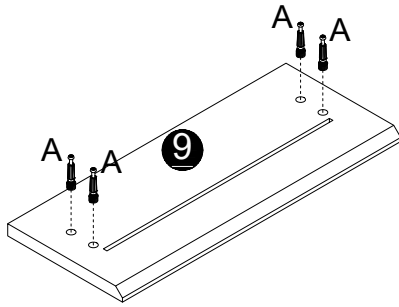

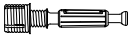
<b>A</b>

Ø6x40mm
12 pcs

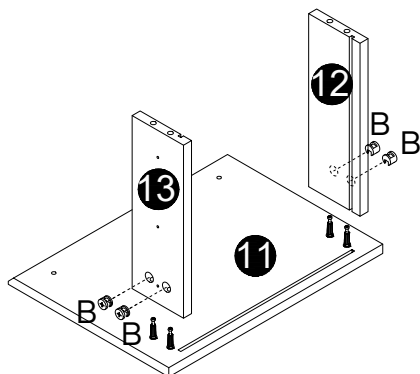
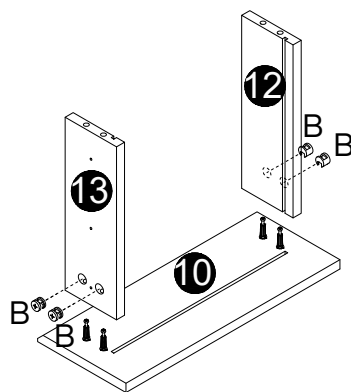
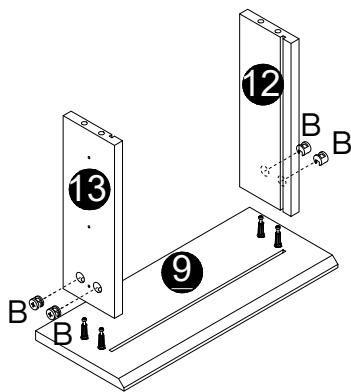
8





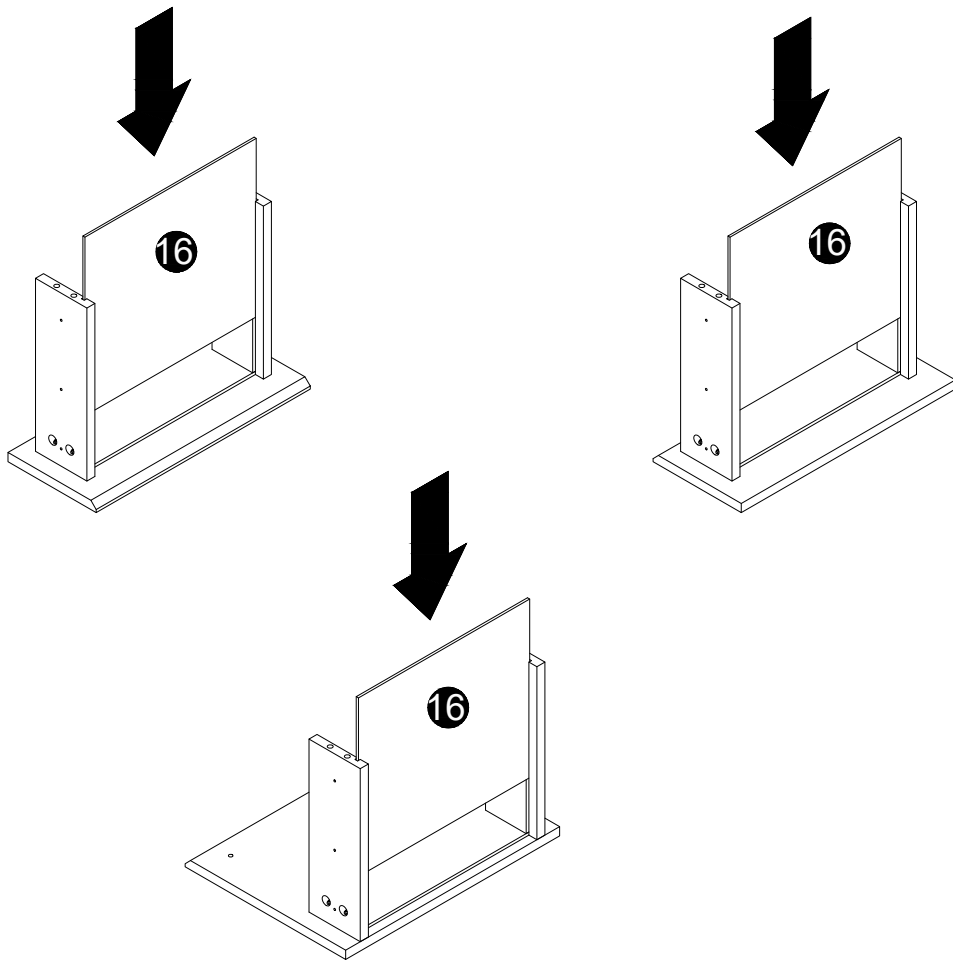

<b>B</b>

Ø15x12mm
12 pcs

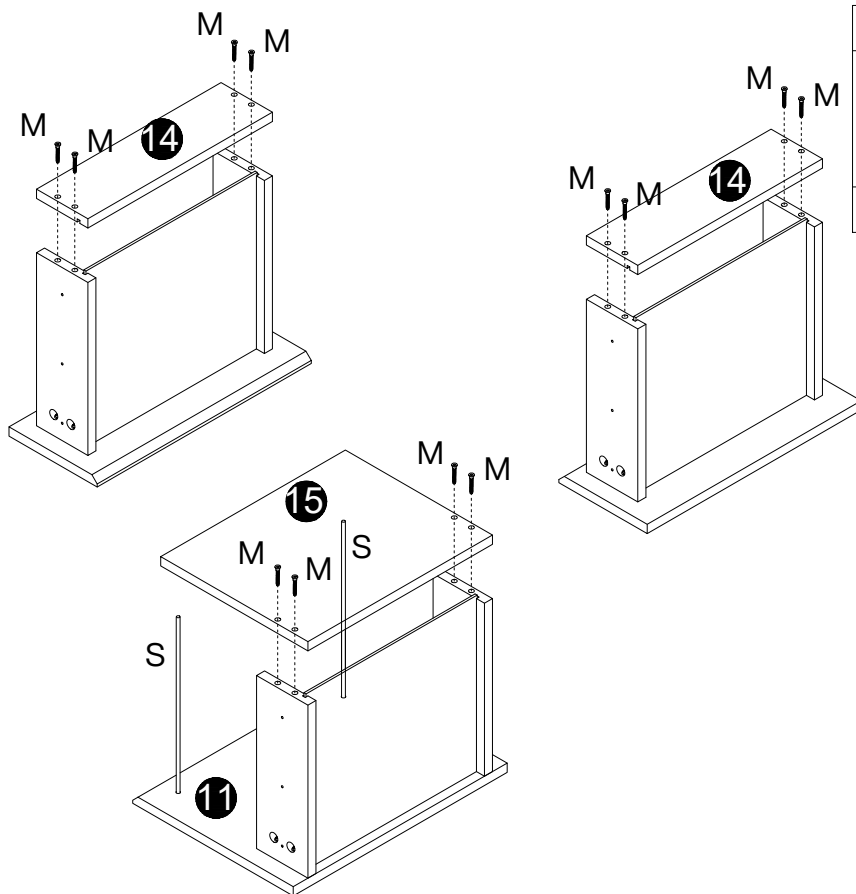
9

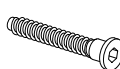

10



S	M	Q
		
Ø5x300mm	Ø5x40mm	M3
2 pcs	12 pcs	1 pc

11

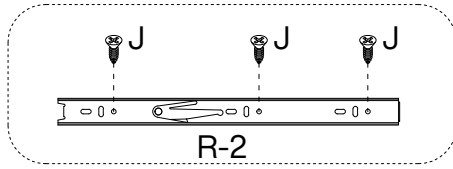

R-2	J
290mm	Ø3.5x14mm
6 pcs	18 pcs

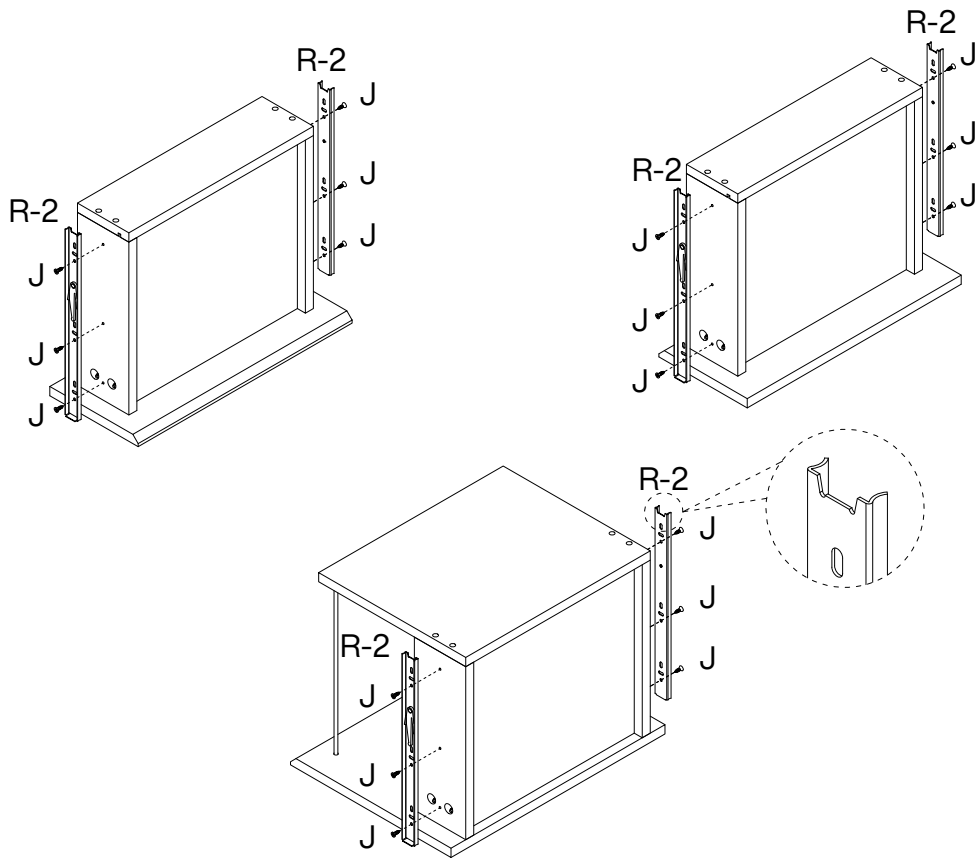

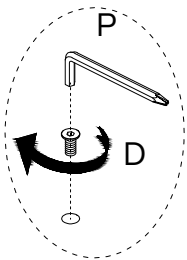

12

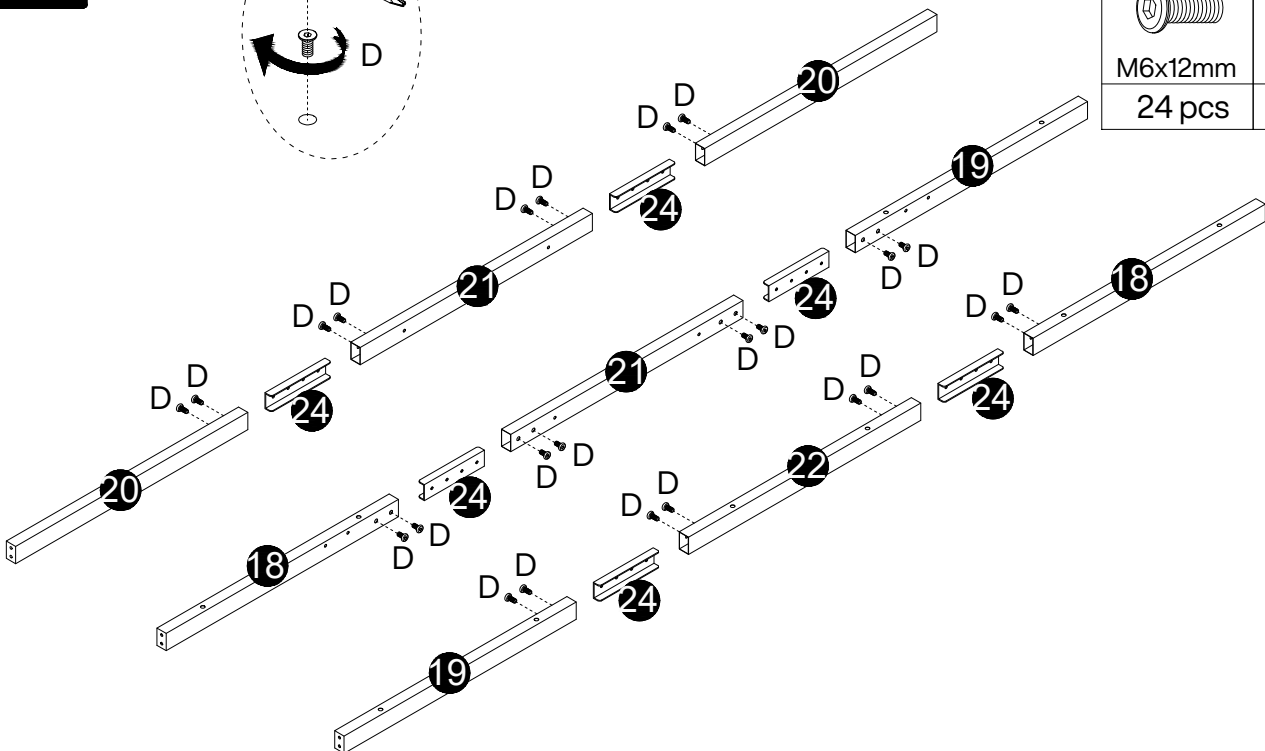

D	P
M6x12mm	M4
24 pcs	1 pc



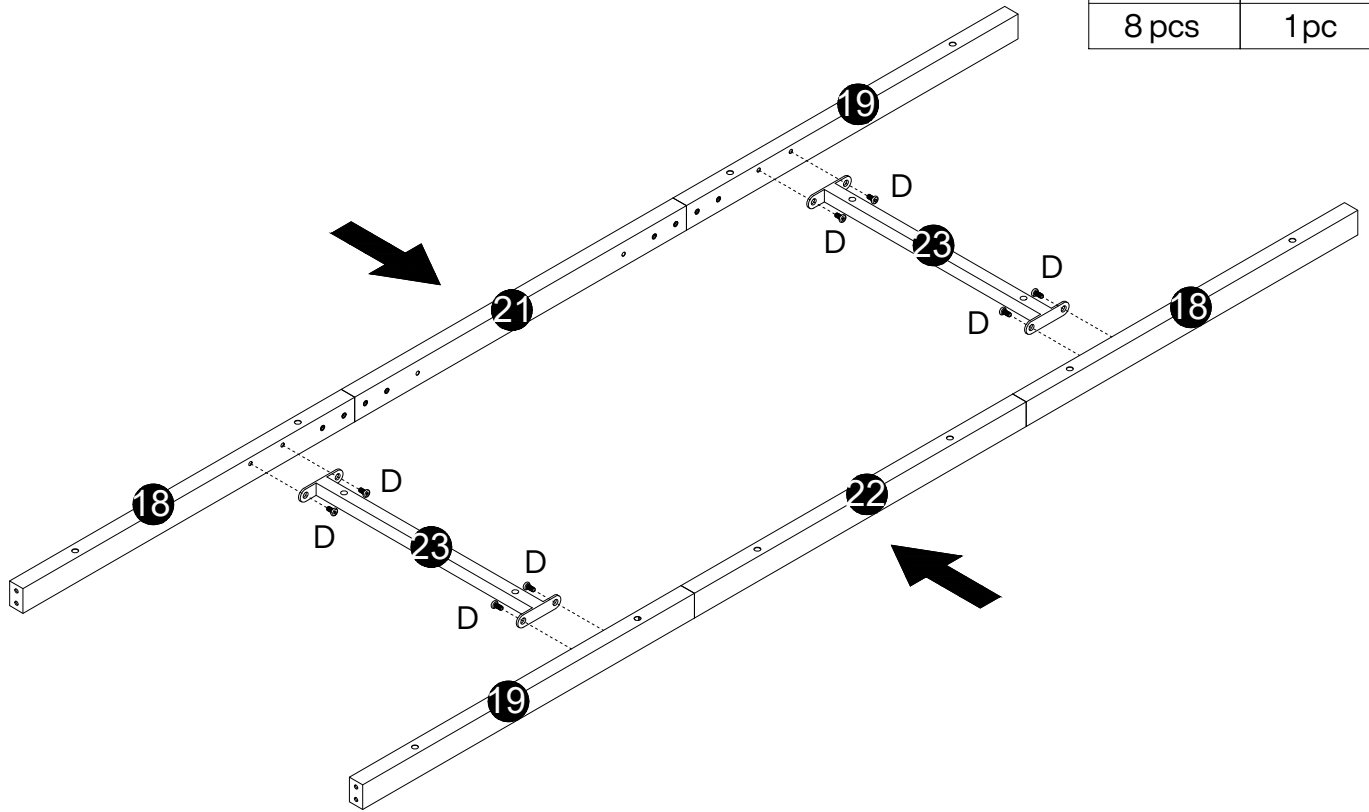

13

D	P
	
M6x12mm	M4
8 pcs	1 pc



14

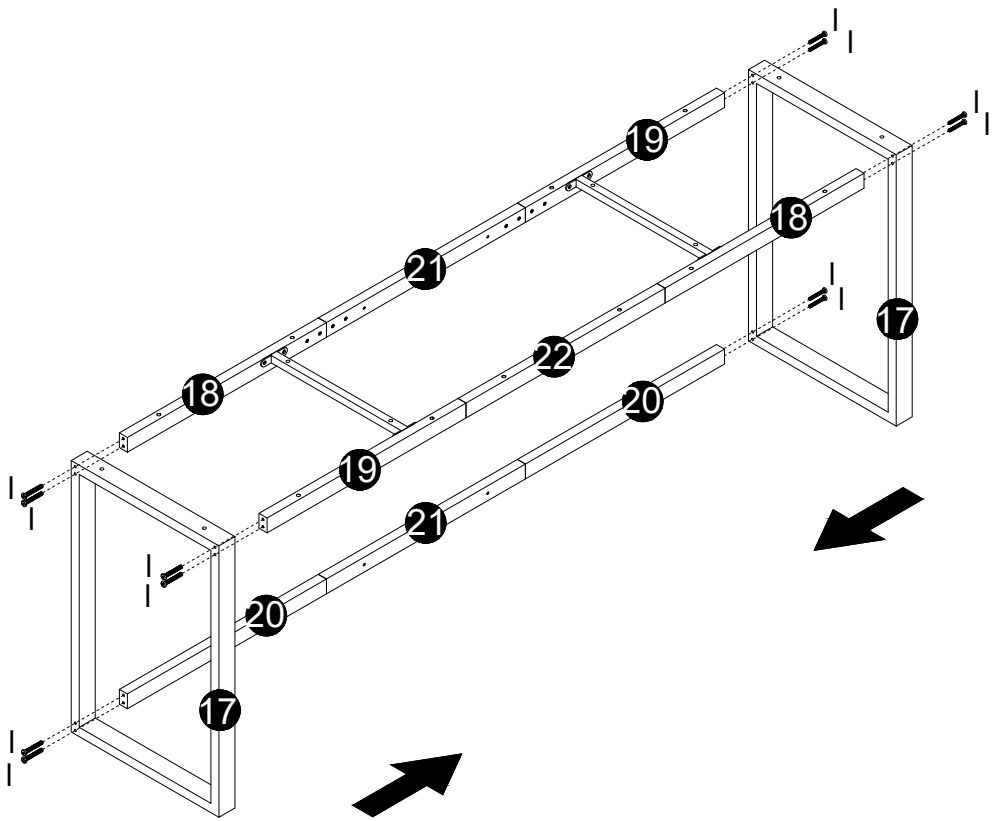

I	P
	
M6x60mm	M4
12 pcs	1 pc

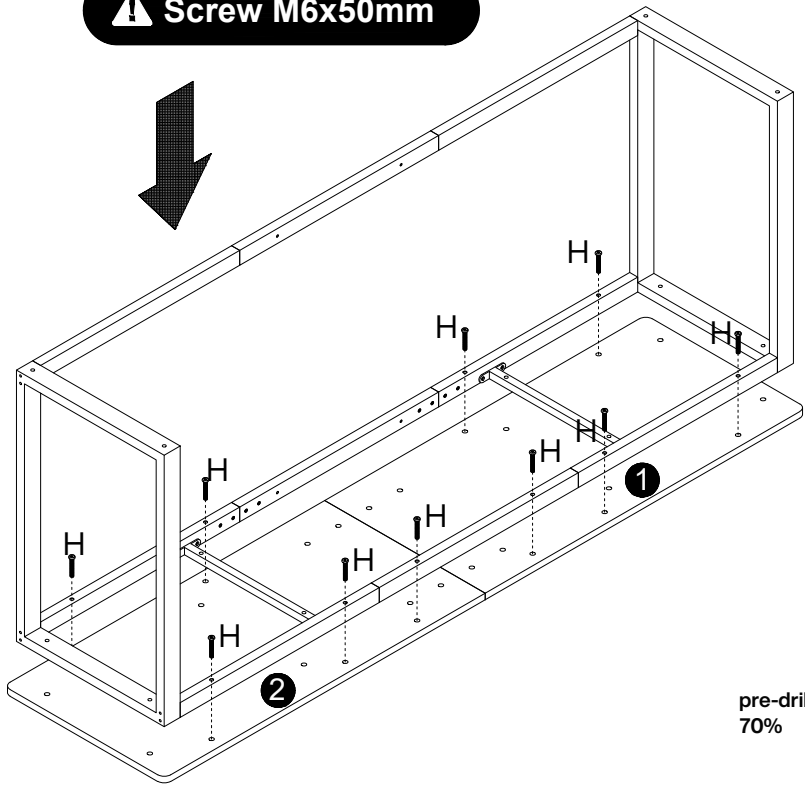

15

⚠ Screw M6x50mm

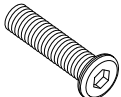

H	P
	
M6x50mm	M4
10 pcs	1 pc

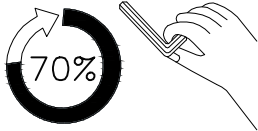

pre-drill  
70%

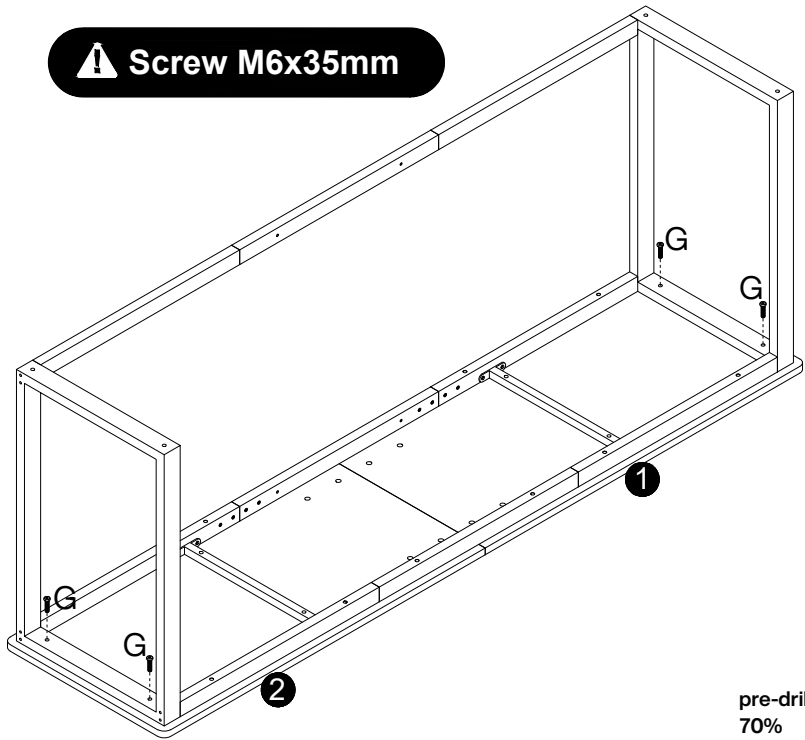

16

⚠ Screw M6x35mm



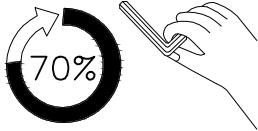

G	P
	
M6x35mm	M4
4 pcs	1 pc

pre-drill  
70%

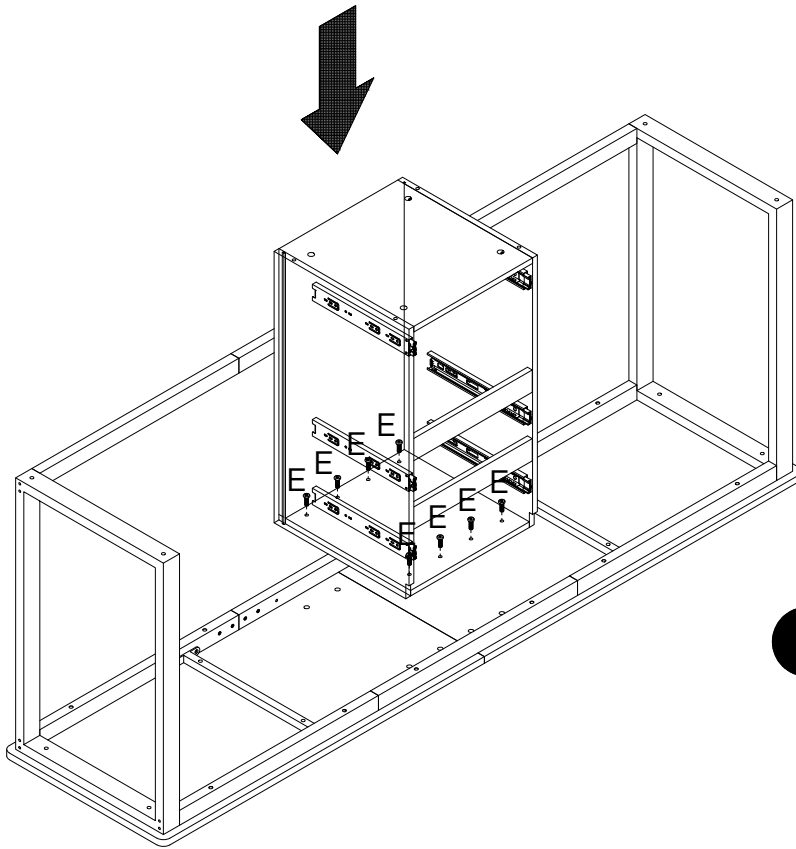

17





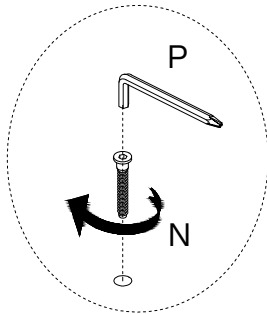

E	P
	
M6x25mm	M4
8 pcs	1 pc

 Screw M6x25mm

18



F	N	O
		
M6x30mm	Ø7x47mm	
4 pcs	4 pcs	8 pcs
		P
		
		M4
		1 pc

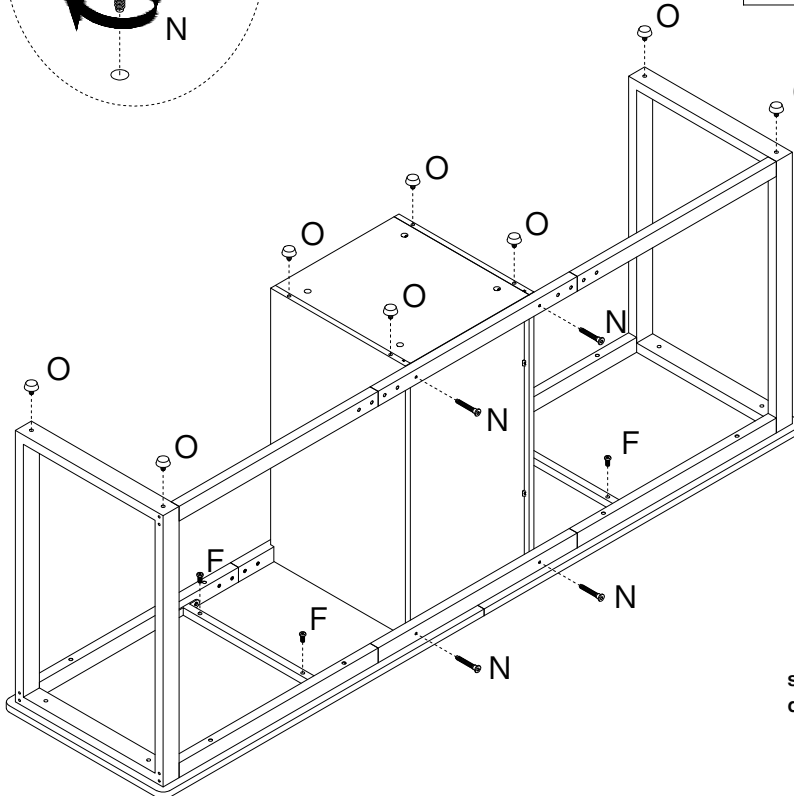

 Screw M6x30mm

screw down

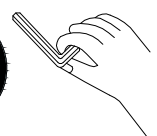
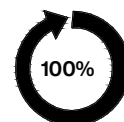

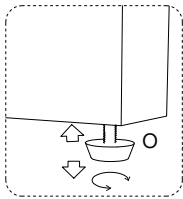
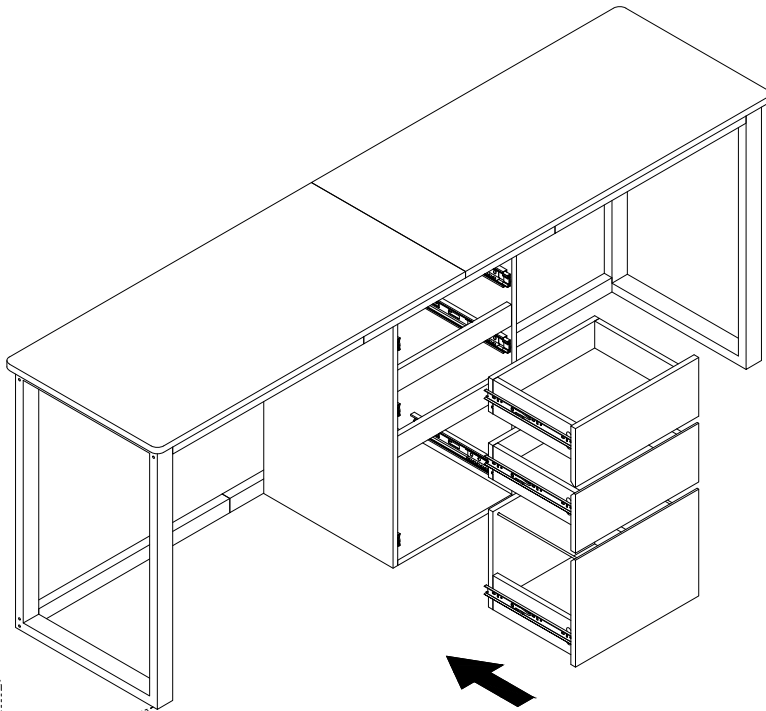

When it is not level on the ground, please adjust here.

Step 1

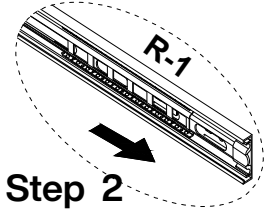

Step 2

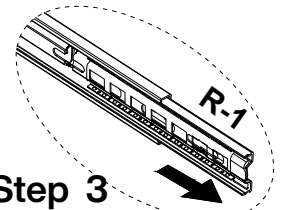

Step 3

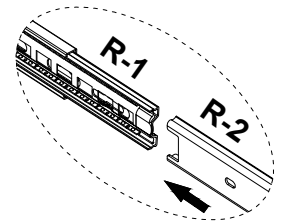

Before installation, slide the inner iron pieces of #R-1 to the outermost side. Then align it with #R-2 and gently push it inward to complete the slide installation.

**Thank you for your support!**

