

# ASSEMBLY INSTRUCTION

## 430- 638 CATON SLAT CHAIR

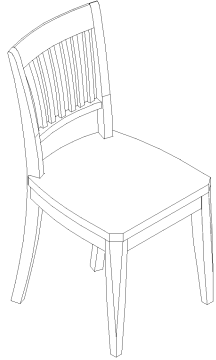

3) Assembly is completed.

### IMPORTANT NOTES :

- . Place all wooden parts on a clean and smooth surface such as a rug or carpet to prevent the parts from being scratched.
- . Check to be sure that you have all parts and hardware.
- . Remove all wrapping materials, including staples and packing straps before you start to assemble.
- . Do not tighten all screws and bolts until completely assembled.
- . Keep all hardware out of the reach of children.

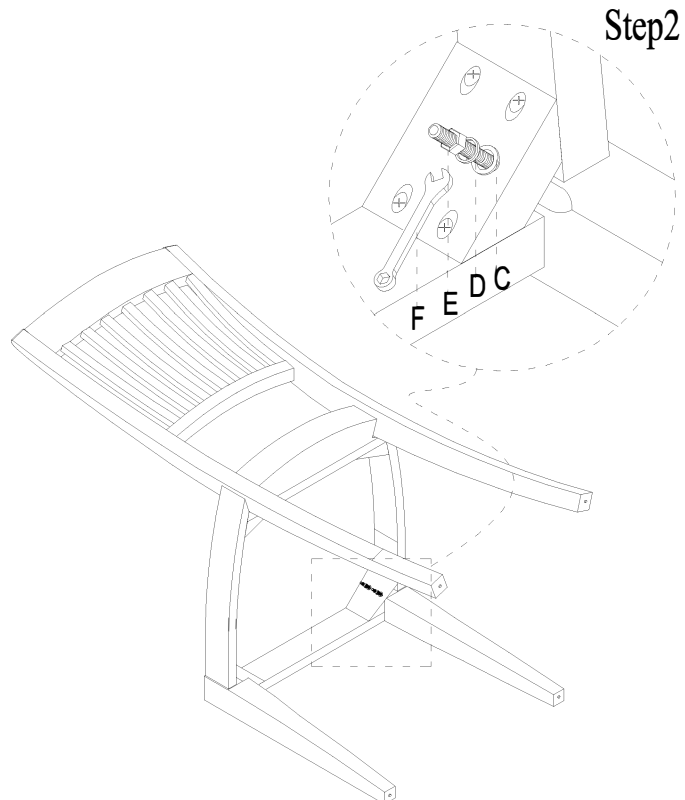
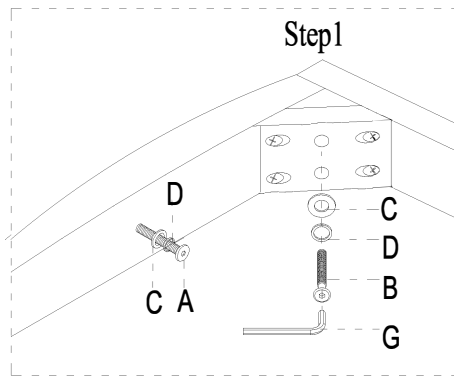
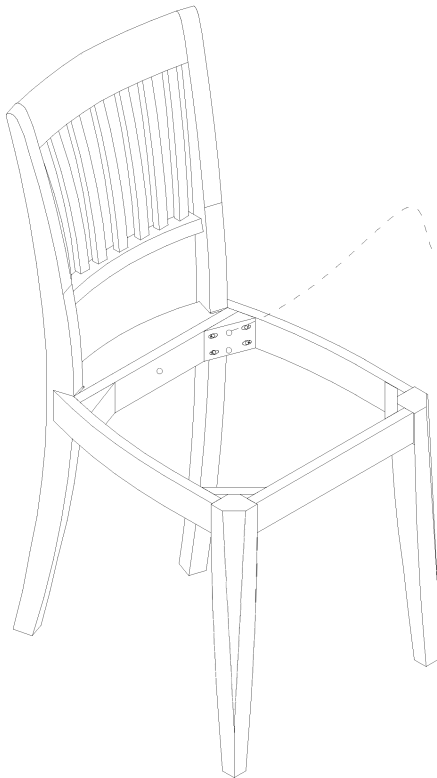

NO.	Dimension	Shape	Quantity
A	Bolt 5/16"*45mm		1pc
B	Bolt 5/16"*76mm		4pcs
C	Flat washer Ø5/16"*19mm		9pcs
D	Lock washer Ø5/16"		9pcs
E	Nuts 5/16"		4pcs
F	Wrench 12mm		1pc
G	Allen Key 4mm		1pc