

# AERE DINING TABLE ASSEMBLY INSTRUCTIONS

## PARTS PACKING CONFIGURATIONS

BOX #1

A. GLASS TOP 1 PC

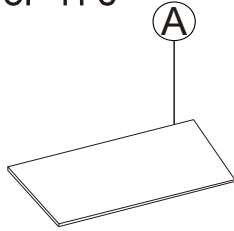

BOX #2

B. WOODEN LEG 1 PC

C. LOWER LEG 1 PC

D. UPPER LEG 1 PC

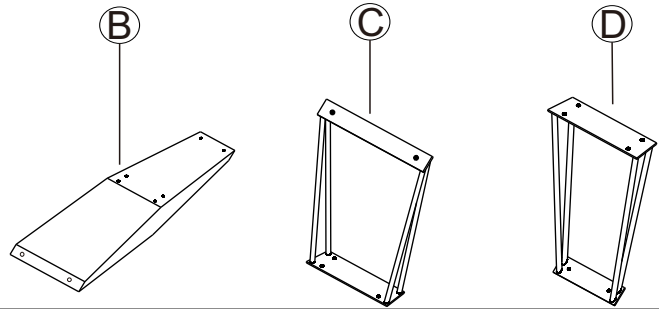

### HARDWARE KIT PACKED IN BOX #2

NO.	DESCRIPTION	IMAGE	Q' TY
1	FLAT WASHER(M8)		12 PCS
2	ALLEN BOLT(8x20mm)		2 PCS
3	ALLEN BOLT(8x35mm)		8 PCS
4	ALLEN BOLT(8x10mm)		2 PCS
5	ALLEN KEY(S5)		1 PC
6	LOCK WASHER(M8)		8 PCS

### FULLY ASSEMBLED

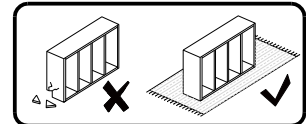
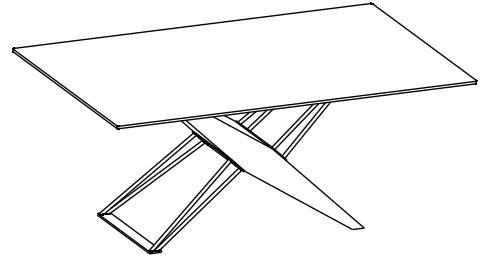

### STEP 1:

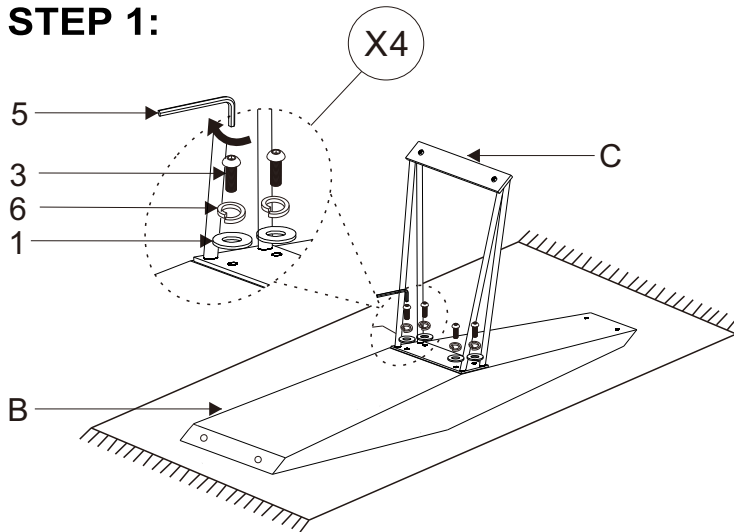

FULLY TIGHTEN BOLTS

### STEP 2:

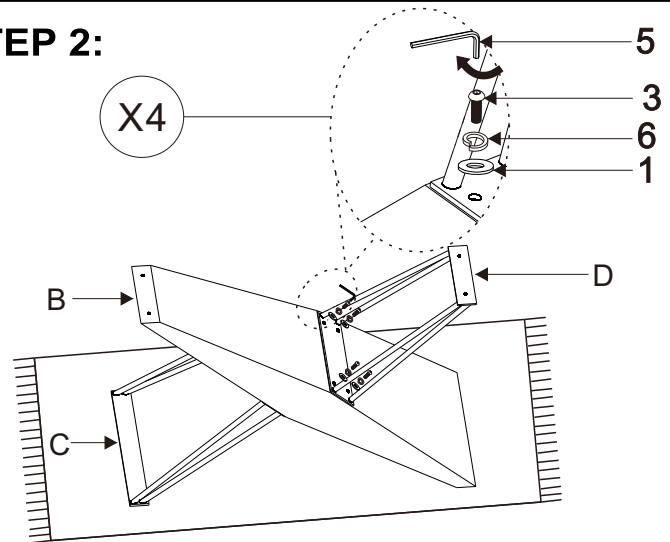

DO NOT TIGHTEN BOLTS COMPLETELY UNTIL FINAL STEP

### STEP 3:

- ① ATTACH WOODEN LEG TO THE TOP, DO NOT FULLY TIGHTEN BOLTS.
- ② ATTACH METAL LEG "D" TO THE TOP.
- ③ FULLY TIGHTEN ALL BOLTS FROM THIS AND THE PREVIOUS STEP.

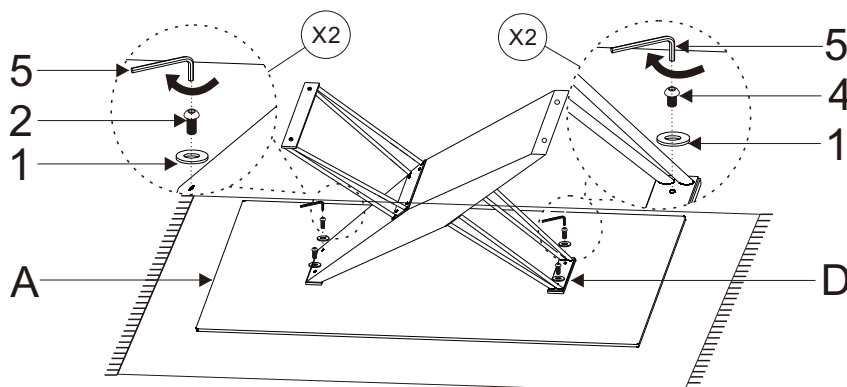

# AERE DINING TABLE ASSEMBLY INSTRUCTIONS

## PARTS PACKING CONFIGURATIONS

**STEP 4:**

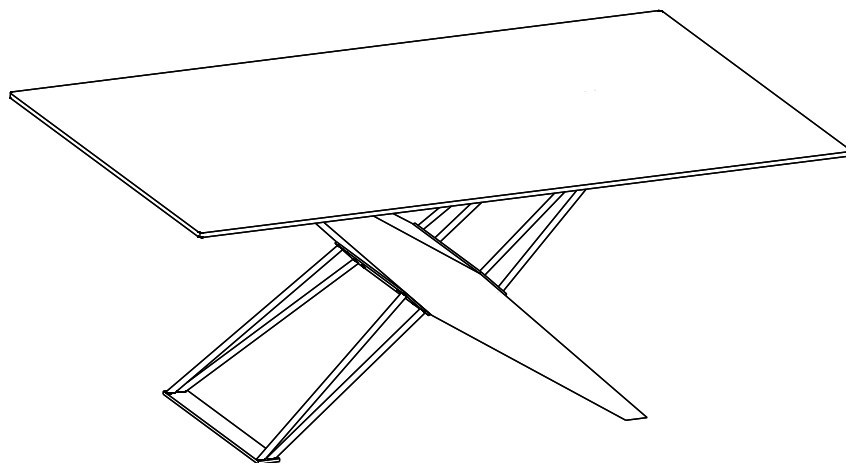
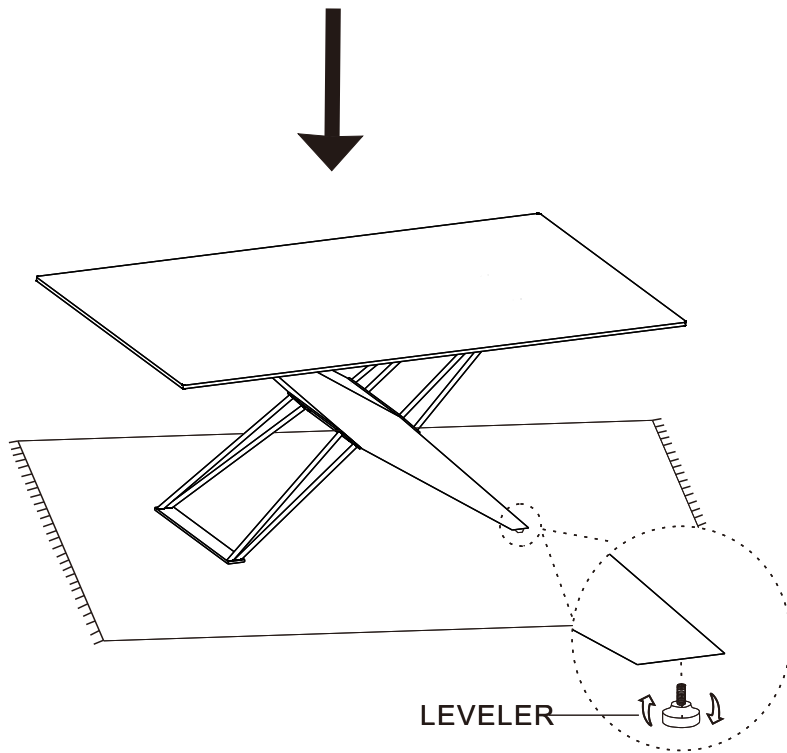
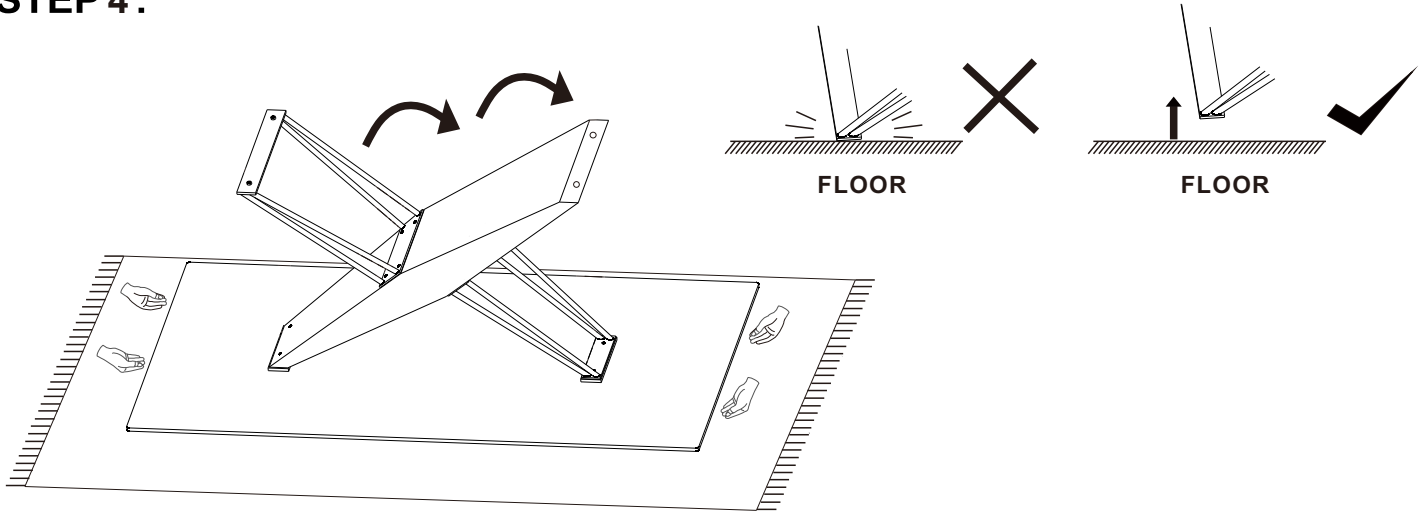

**ASSEMBLY COMPLETE**