

# Mid-Century Modern Sofa

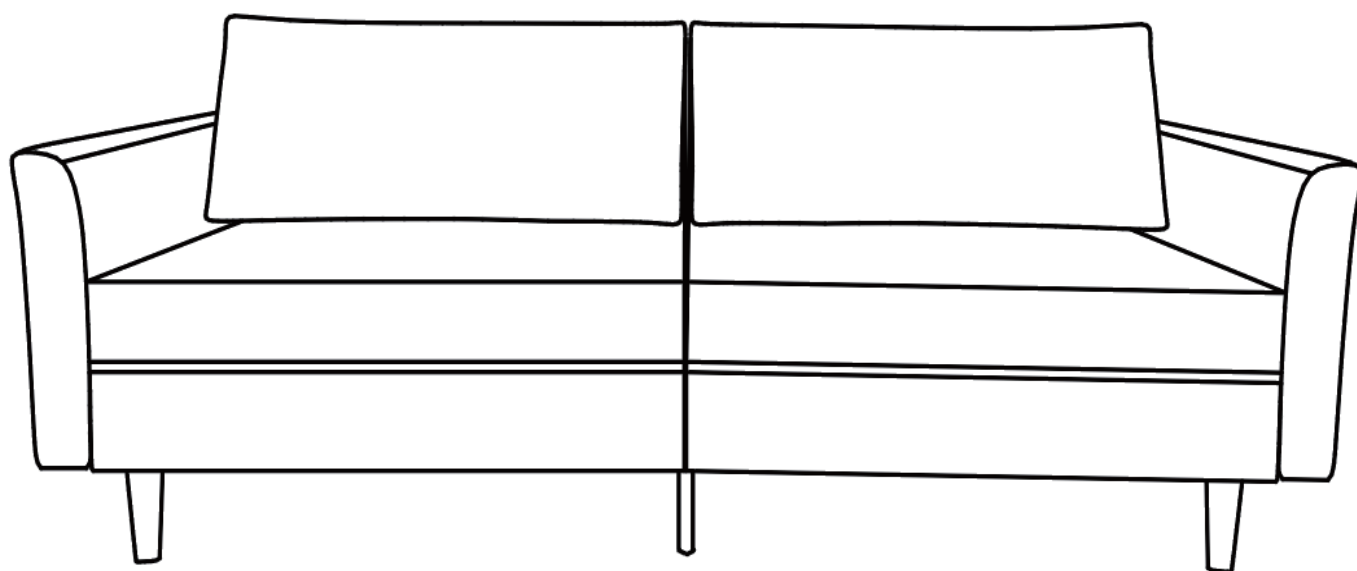

ASSEMBLY INSTRUCTIONS

# Before you start...

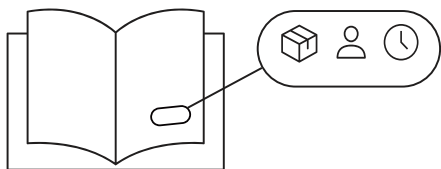

Ensure you have received all cartons and familiarize yourself with the workload. Make sure there are enough helping hands to assist you, and that you have allocated the time required to assemble your new product.

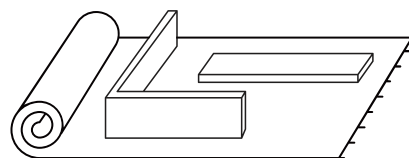

Make sure you have cleared enough space in your home for the assembly. We recommend protecting your floor with a mat or cardboard to avoid scratches during the assembly process.

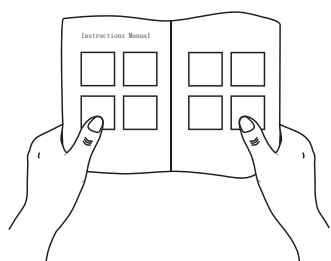

Read instructions carefully and check no parts are missing.

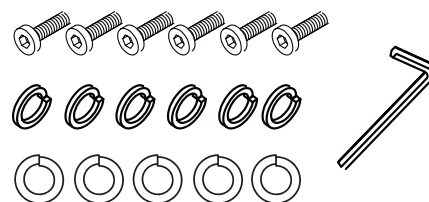

Lay out all hardware on a soft surface so you can easily identify them.

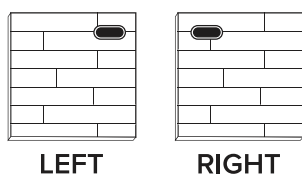

Carefully identify all components in order to differentiate which pieces are left and right.

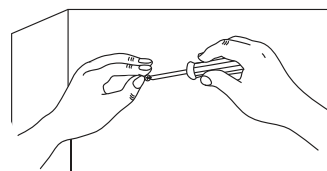

Install your new product carefully following the instructions. Don't skip ahead!

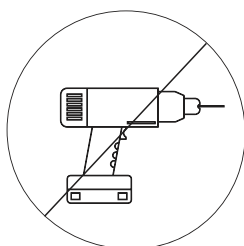



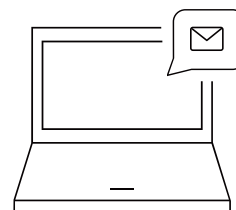

**DO NOT** over tighten screws or use a drill. It will damage the product.





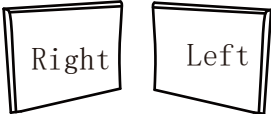



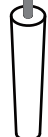
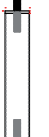

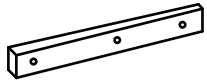
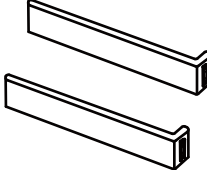
If you need further assistance with assembling your product, please chat with us .

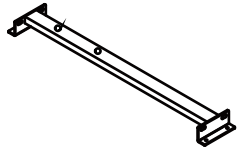



# PARTS LIST

## BOX1

Part	A-backrest	B-armrest	C1	C2	C3	D1	D2
Description						MIDDLE 	REAR 
Qty	1Pair	1Pair	2PC	1PC	1PC	1PC	1PC

Part	E	F	G	H
Description				
Qty	4PC	1Pair	1PC	1PC

Part	I	J	K	L	M
Description	SOFA SEAT BOARD 	ALLEN KEY 	M8*60 	8.5*17*2mm 	M6*30 
Qty	2PC	1PC	8PC	29PC	6PC

Part	N	O	P1	P2	Q
Description	M5*25 	M8*40 	M6*50 	M6*40 	
Qty	4PC	2PC	13PC	6PC	1PC

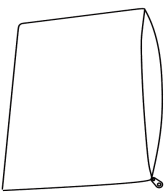
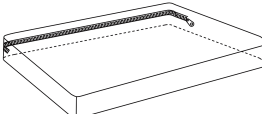
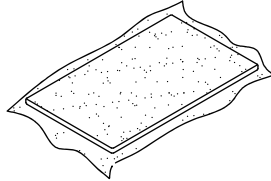
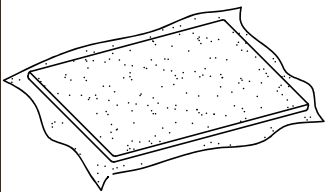
Part	S	T	U	V
Description				
Qty	2PC	2PC	2PC	2PC

# ASSEMBLY STEPS

Step1:

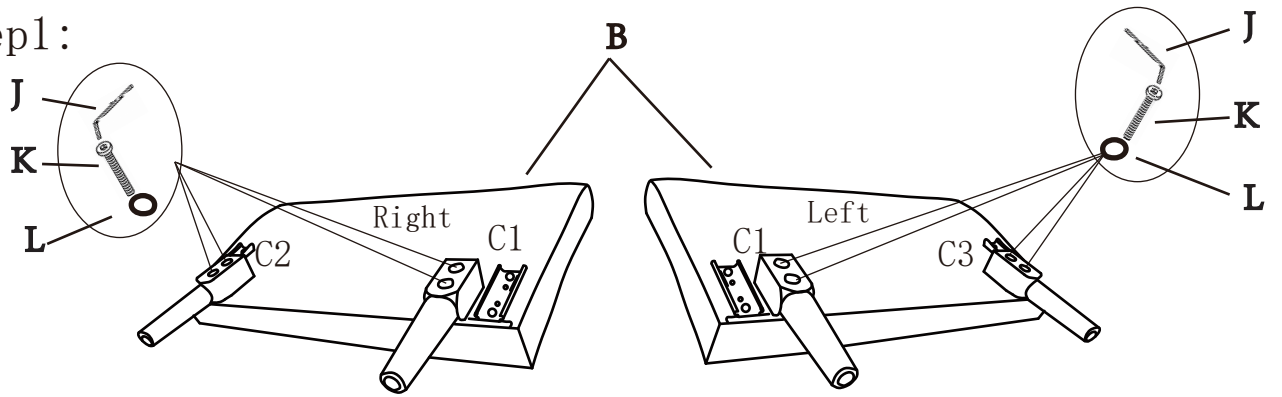

Align the screw holes in the left and right arms frame.

Step2:

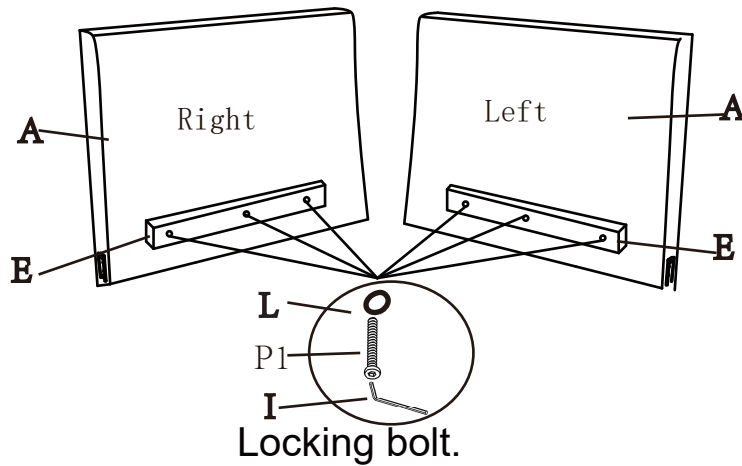

Locking bolt.

Step3:

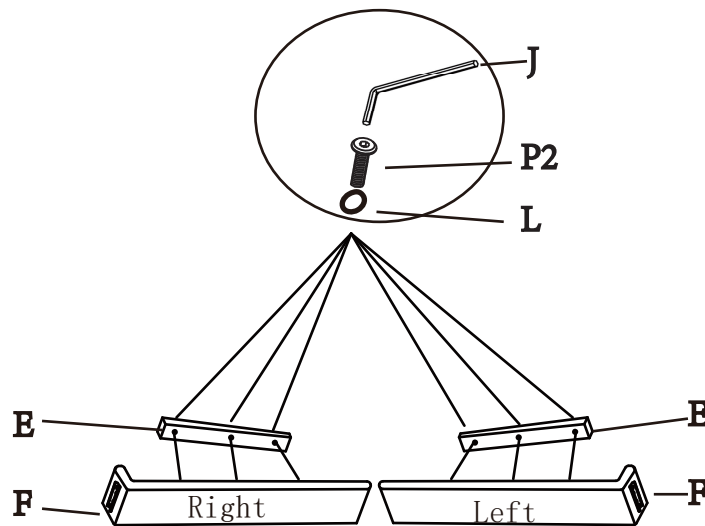

Connect and fix two boards of the front seat frame.

Step4:

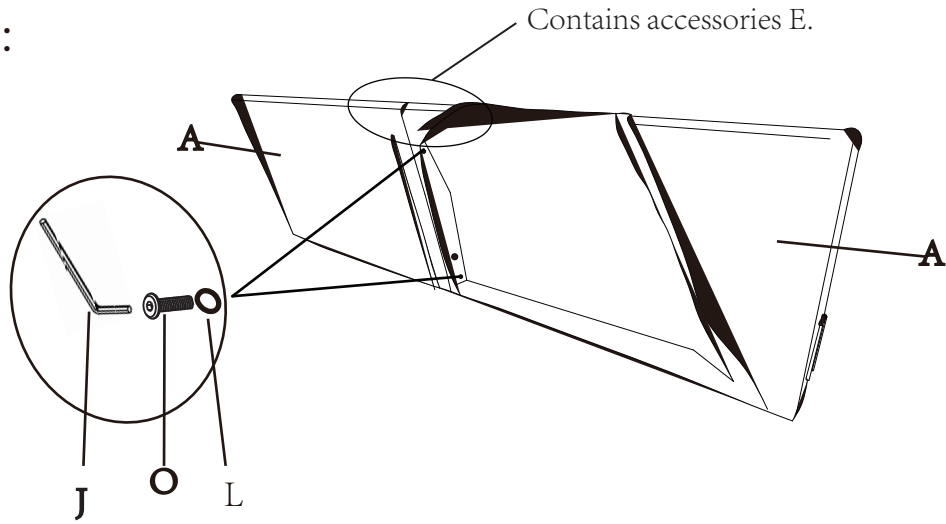

Align the holes of the left and right backrests and fix them with screws.

---

Step5:

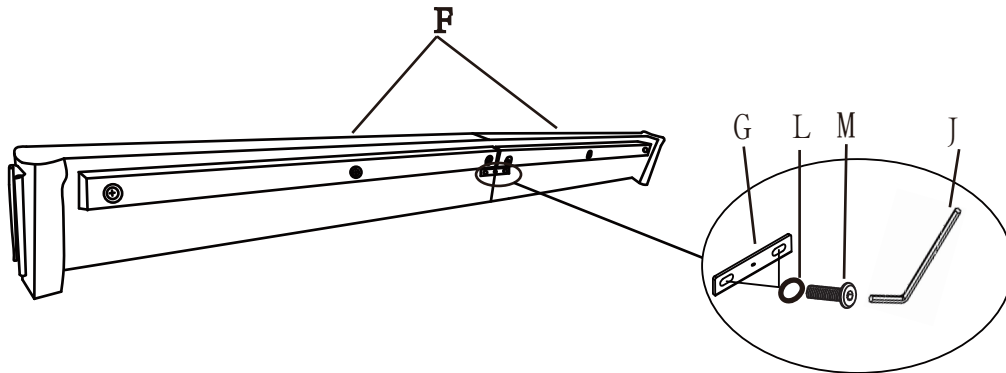

Connect and fix two boards of the front seat frame.

---

Step6:

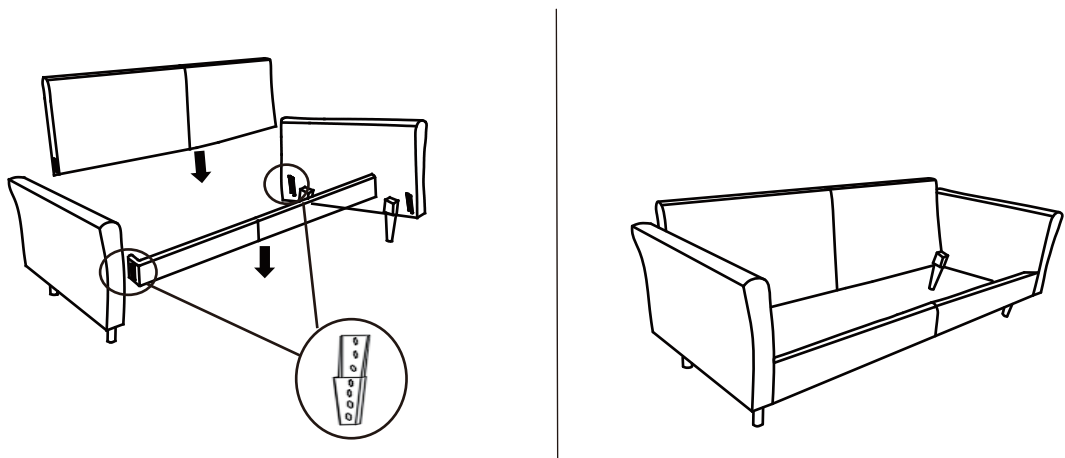

Align and insert down into slot

Step7:

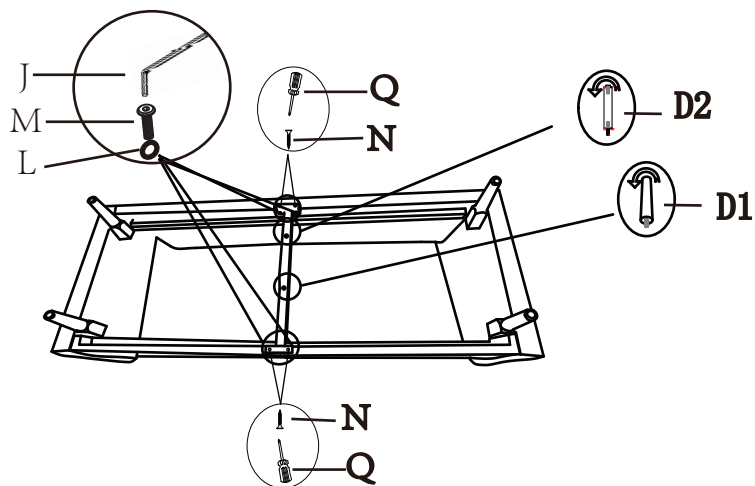

Install and fix the bottom connecting rod of the sofa with screws.  
Rotate the middle leg and fix it.

Step8:

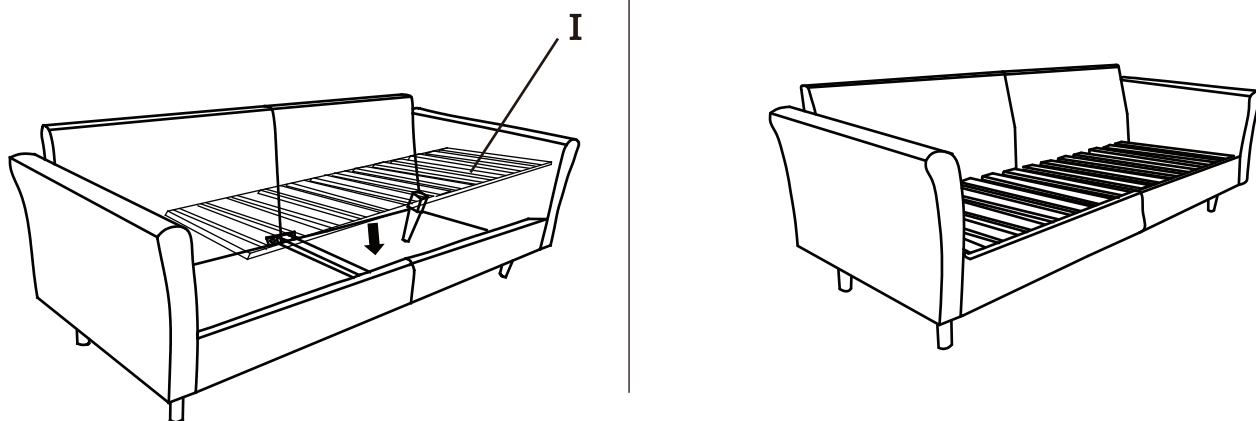

Lay the slats on the sofa frame. Make sure to fix them  
with Velcro.

Step9:

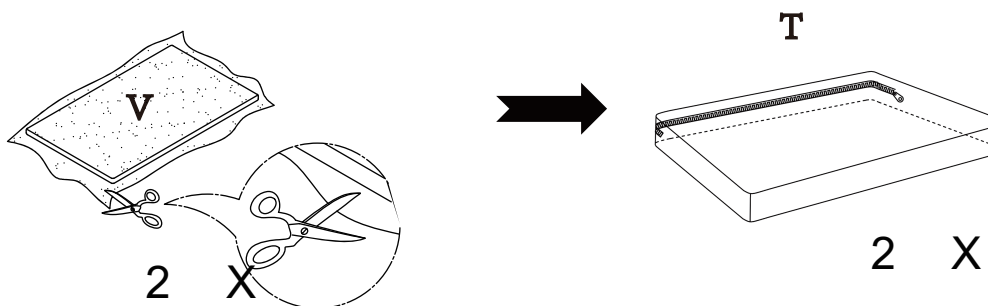

Open the zip and place the seat cushion pads evenly and flatly insi  
de the cover.

Step10:

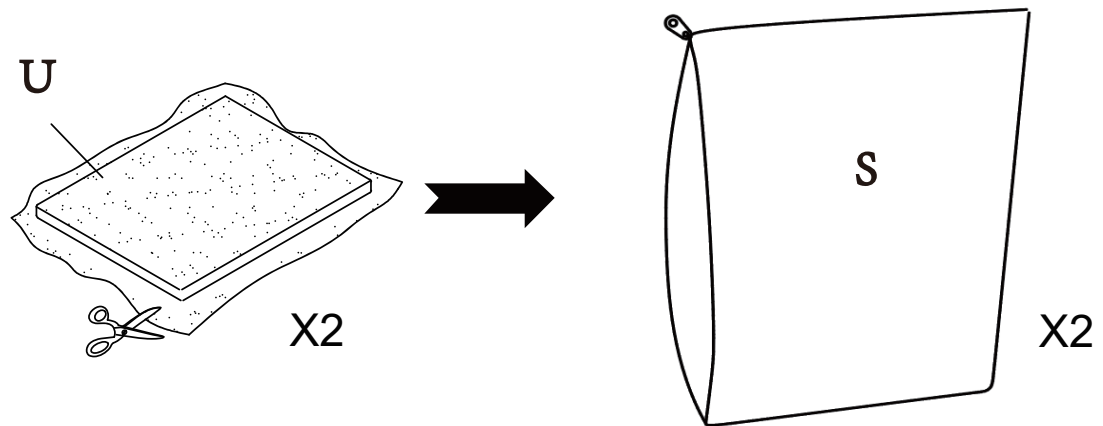

Open the zip and place the back cushion pads evenly and flatly inside the cover.

The cushions are compressed and require a recovery period after opening, with a maximum recovery time of 48 hours.

---

Step11:

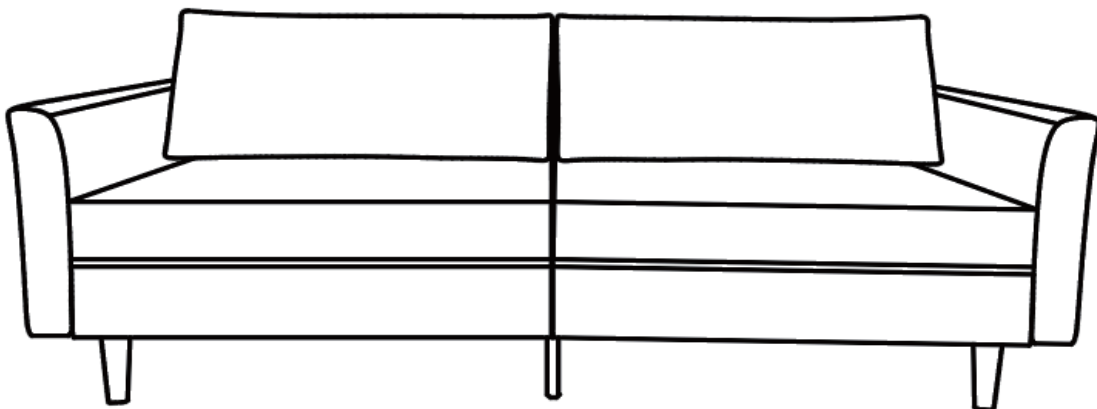

Please note that the centre legs are shorter than the other legs to ensure the load bearing and structural stability of the sofa.

# FINISHED!

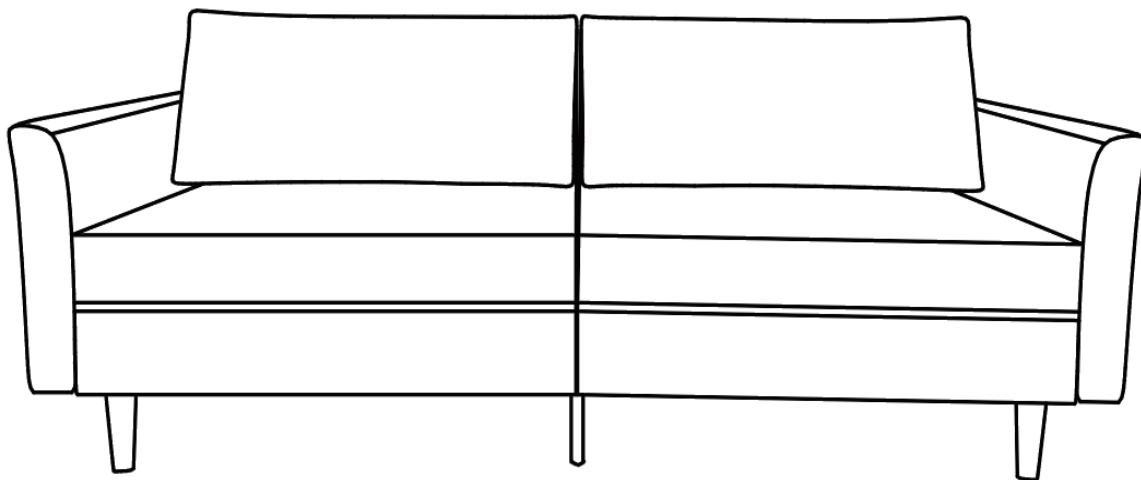

**Congratulations! We're almost there! Please perform following checks to ensure assembly is properly done.**

- Have you tighten all the screws?  
Sit on the couch to check if the legs are shaky.
- Are the back cushions and armrests fixed properly?  
Try pushing them to check if they are tightly in position.
- Adjust and pull the fabric upholstery to remove any wrinkles and ensure correct placement.

Move your product carefully, with 2 people lifting it to the preferred location. Clean the product with a damp cloth. You are all set!

Enjoy your fresh and updated living space thanks to the addition of your new product!

# Frequently Asked Questions

We understand that receiving damaged or defective products can be disappointing, and we're here to assist you every step of the way. Here's how to address common concerns and initiate a damage claim:

## **1.What should I do if my shipment is damaged or products received are defective?**

We're genuinely sorry to hear about any inconvenience caused. Please reach out to us promptly, and our team will prioritize resolving the matter swiftly and effectively. To file a damage claim, follow these steps:

A. Retain the original box in case a return is required.

B. Take photos of the damaged box, the damaged part of the item, tracking number, and return label on the box to help us process a replacement or refund.

## **2.Can I return the product if I'm not satisfied?**

While we uphold stringent quality standards and collaborate with experienced manufacturers, we acknowledge that dissatisfaction may arise. If you're still unsatisfied, you can initiate a return within 30 days of receiving the product. Simply message us with your reasons for return, and we'll facilitate the process.