

HEADBOARD

ASSEMBLY INSTRUCTIONS

Before assembling your headboard, please read through these instructions carefully and familiarize yourself with the different parts.

ATTENTION! If you receive a damaged or defective item, please contact affurnishings



PARTS LIST

- 1 TOP / BOTTOM RAIL 2 PCS
- 2 SLAT 8 PCS
- 3 WIDE SLAT 1 PC
- 4 LEFT LEG 1 PC
- 5 RIGHT LEG 1 PC

Instructions apply for bed sizes
FULL

HARDWARE

- A** JCB M6 X 110mm - 4 pcs
Spare - 1 pc
 - B** Barrel Nut - 4 pcs
 - C** JCB M8 X 15mm (5/8") - 4 pcs
 - D** Allen wrench - 1 pc
Spare - 1 pc
- Assembly headboard to open bed frame*

HARDWARE FOR METAL BED FRAME

- E** JCB M6 X 25mm (1") - 4 pcs
Spare - 1 pc
- F** Flat washer - 4 pcs
Spare - 1 pc
- G** Split washer - 4 pcs
Spare - 1 pc

NOTE: WE INCLUDE SPARE HARDWARE IN CASE DAMAGE OCCURS DURING ASSEMBLY.

Step 1

Attach the slat (2) and wide slat (3) to the top and bottom rail (1) as shown.

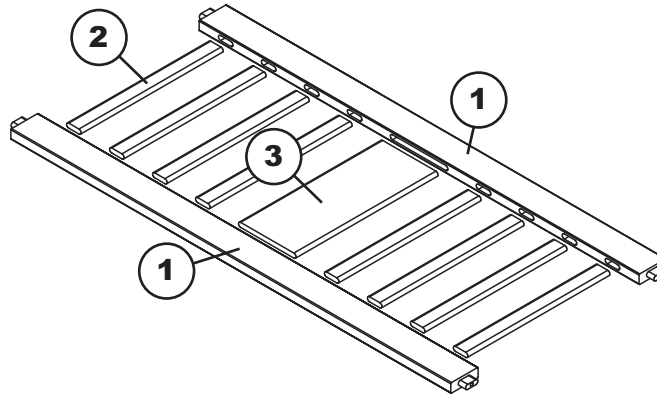

Step 2

Attach the left leg (4) and right leg (5) to the rail assembly as shown. Using JCB (A) and barrel nut (B). Tighten with Allen wrench (D).

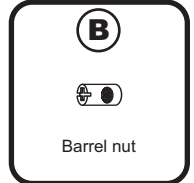
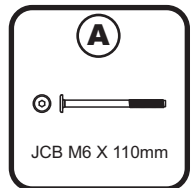
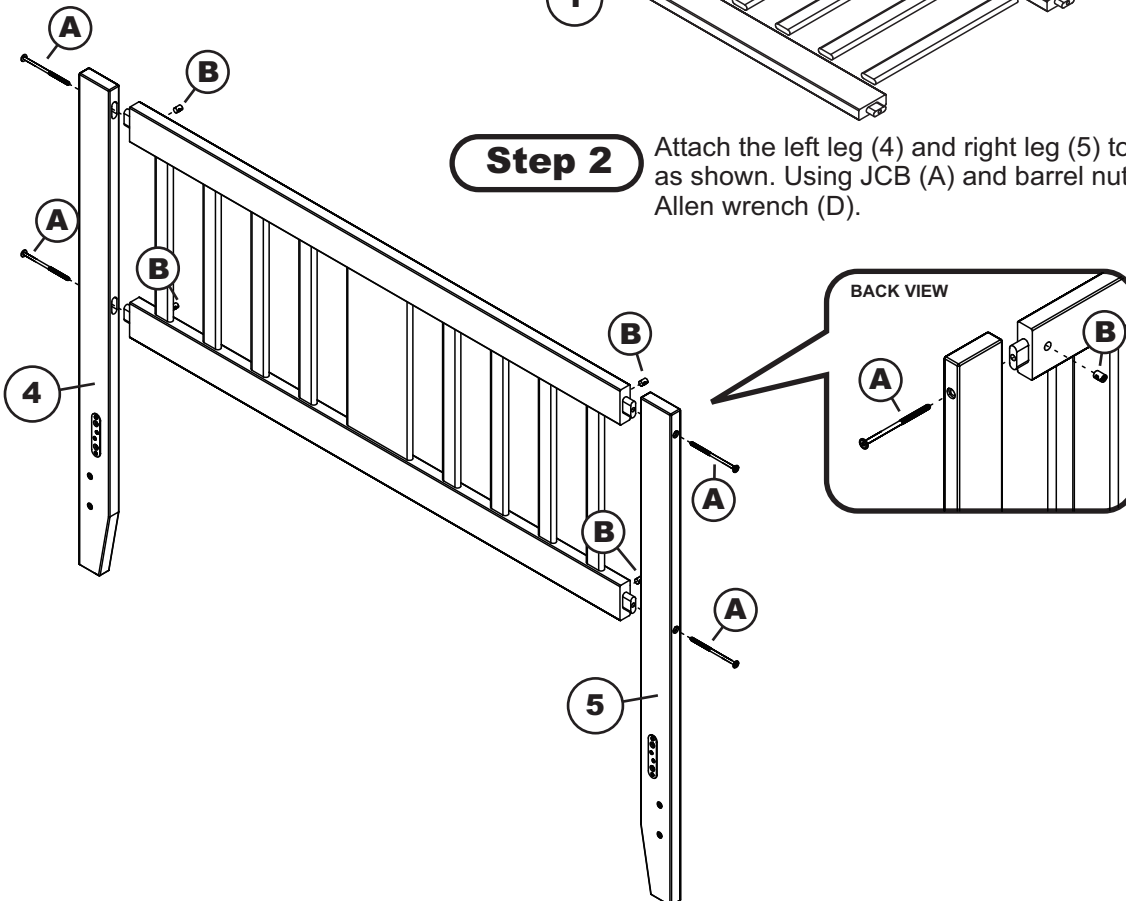

FOR BED FRAME ASSEMBLY follow assembly instructions included with your bed frame.
If you purchased a wood headboard to attach to metal bed frame, please refer to page 2.

ATTACHING HEADBOARD TO METAL BED FRAME

ASSEMBLY INSTRUCTIONS

Before assembling your bed, please read through these instructions carefully and familiarize yourself with the different parts.

Instructions apply for bed sizes
Twin > Full > Queen



Adult assembly

Metal bed frames are sold separately from wood headboards. The hardware shown on this page is supplied with your wood headboard for attaching the bed frame to the headboard. The metal bed frame is supplied with its own assembly instructions and hardware.

Step 1

Attach the headboard assembly to the metal bed frame using JCB M6 X 1" (E), flat washer (F), and split washer (G) then tighten with Allen wrench (D) as shown below.

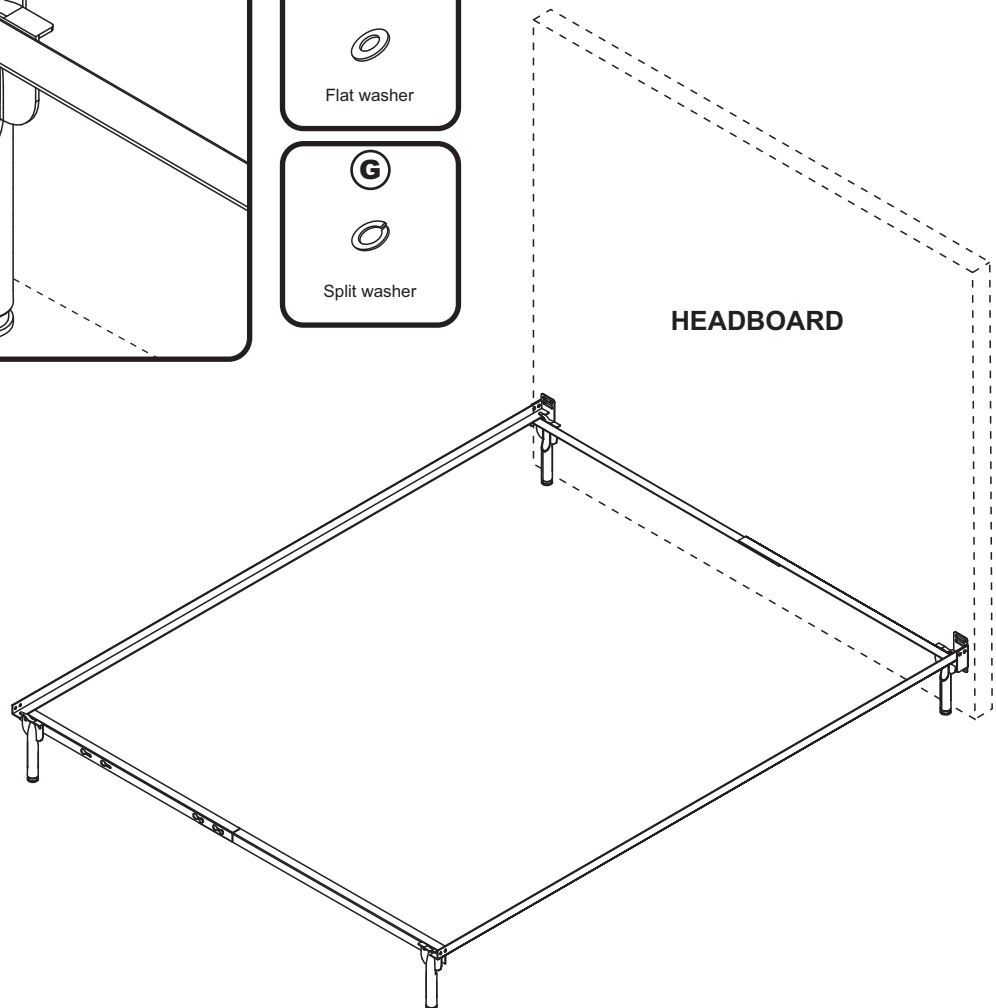
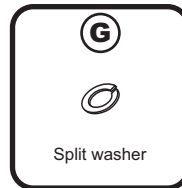
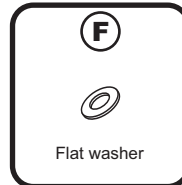
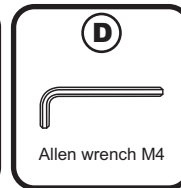
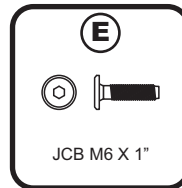
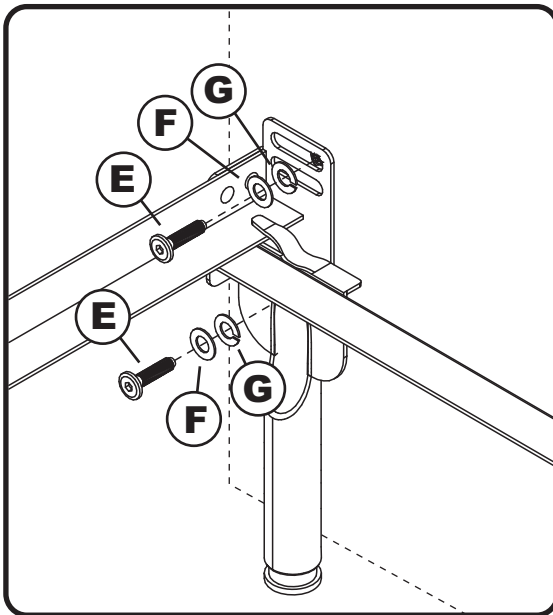

Congratulations!

Your bed is now ready for use.

To ensure lasting safety, we recommend that you periodically check that all screws are tight and all parts are secure.

BED FRAME

afifurnishings.com

FULL ASSEMBLY INSTRUCTIONS

Before assembling your bed frame, please read through these instructions carefully and familiarize yourself with the different parts.

ATTENTION! If you receive a damaged or defective item, please contact afifurnishings



PARTS LIST

①	FOOT RAIL	1 PC
②	LEFT LEG	1 PC
③	RIGHT LEG	1 PC
④	SIDE RAILS	2 PCS
⑤	SLAT KIT	2 SETS
⑥	SLAT SUPPORT 1	1 PC
⑦	SLAT SUPPORT 2	1 PC
⑧	SUPPORT LEGS	3 PCS

HARDWARE

ⓐ	JCB M6 X 110mm (4 3/8") - 2 pcs Spare - 1 pc	ⓔ	JCB M6 X 25mm(1") - 4pcs
ⓑ	Barrel nut - 2 pcs	ⓕ	Cap nut - 4pcs
ⓒ	JCB M8 X 15mm (5/8") - 4 pcs	ⓖ	Allen Screw - 3pcs
ⓓ	Wood screw(1 1/4") - 25 pcs Spare - 2 pcs	ⓓ	Allen wrench M6 - 1pc
		ⓓ	Allen wrench M4 - 1pc Spare - 1pc

NOTE: WE INCLUDE SPARE HARDWARE IN CASE DAMAGE OCCURS DURING ASSEMBLY.

Step 1

Attach the legs (2) and (3) to foot rail (1), using JCB M6 X 110mm (A) and barrel nut (B).
Tighten with the Allen wrench M4 (I).

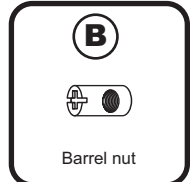
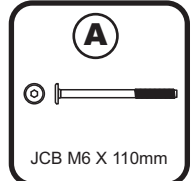
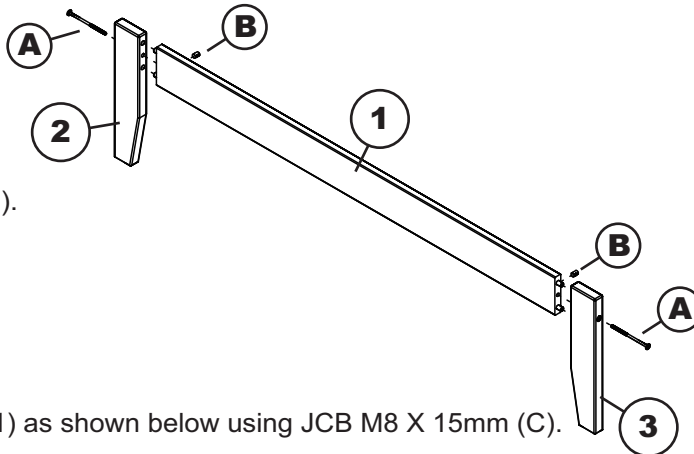

Step 2

Attach side rails (4) to the foot rail (1) as shown below using JCB M8 X 15mm (C).
Tighten with Allen wrench M6 (H).

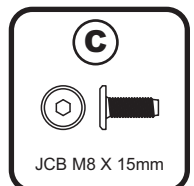
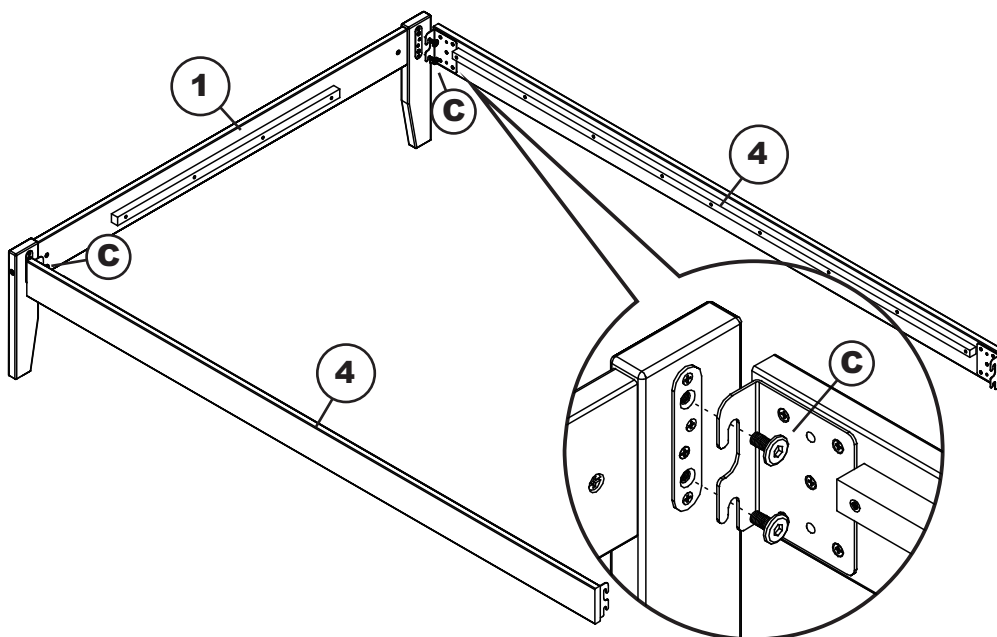

BED FRAME

all trademarks are the property of their respective owners.

FULL



Step 3

Attach open bed frame to the headboard as shown below using 4 JCB M8 X 15mm bolts that are supplied with your headboard. Tighten with the Allen wrench M6 (E).

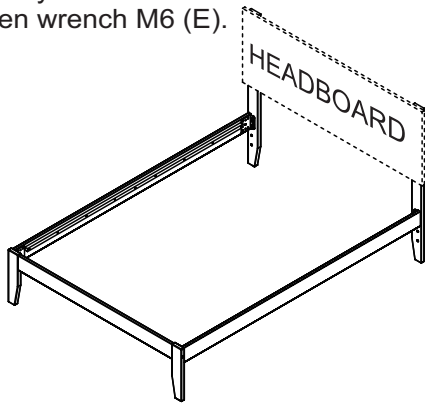
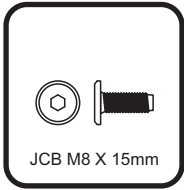

Step 4

Attach support legs (8) to slat support 1 & 2 (6)(7) as shown below using Allen screw (G) tighten with Allen wrench M4 (I).

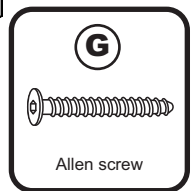
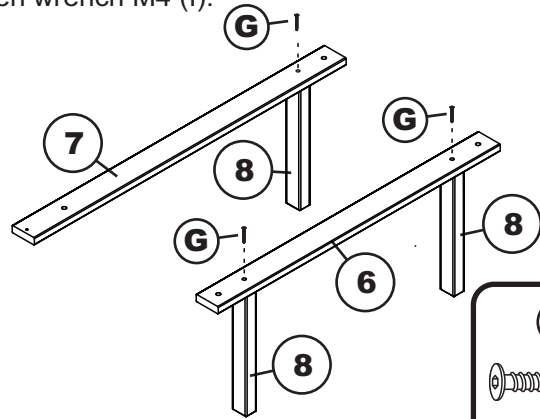

Step 5

Attach slat support 1(6) and slat support 2 (7) to the slat kit (5) as shown below using JCB M6 X 25mm (E) and cap nut (F). Tighten with Allen wrench M4 (I).

2 legs at headboard section.

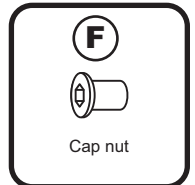
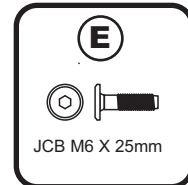
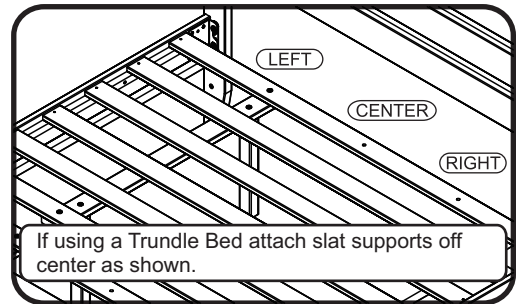
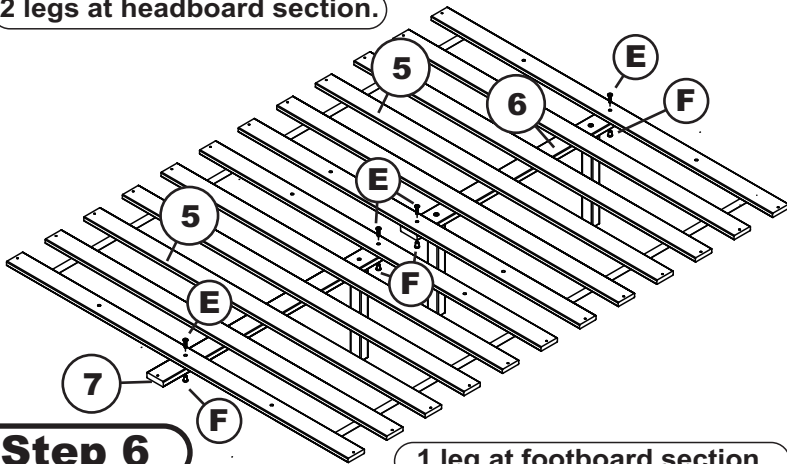

Step 6

1 leg at footboard section.

Attach 2 slat kits (5) to the open bed frame as shown below using wood screws 1 1/4" (D). Tighten with Phillips head screw driver. (customer supplied)

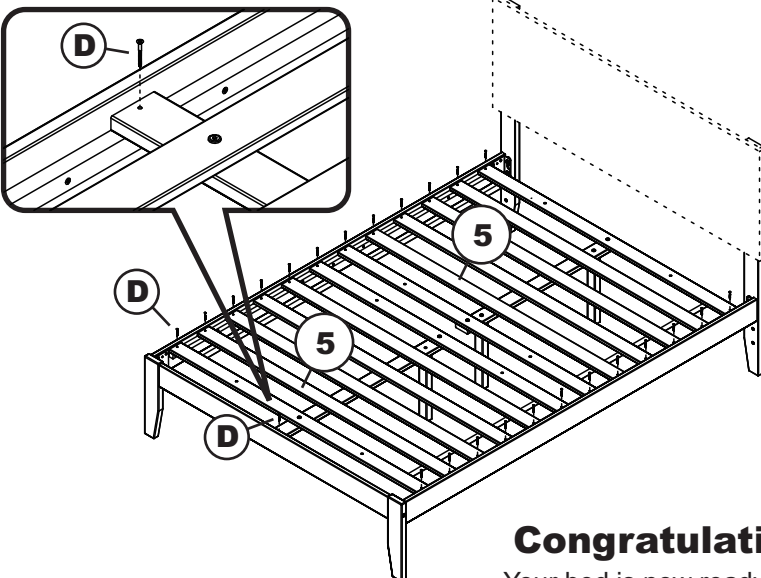

Congratulations!

Your bed is now ready for use.

We recommend that you periodically recheck that all screws are tight to ensure lasting safety.

TRUNDLE BED

af.furnishings.com

TWIN ASSEMBLY INSTRUCTIONS

Before assembling your Trundle bed, please read through these instructions carefully. Familiarize yourself with the different parts.



ATTENTION! If you receive a damaged or defective item, please contact af.furnishings

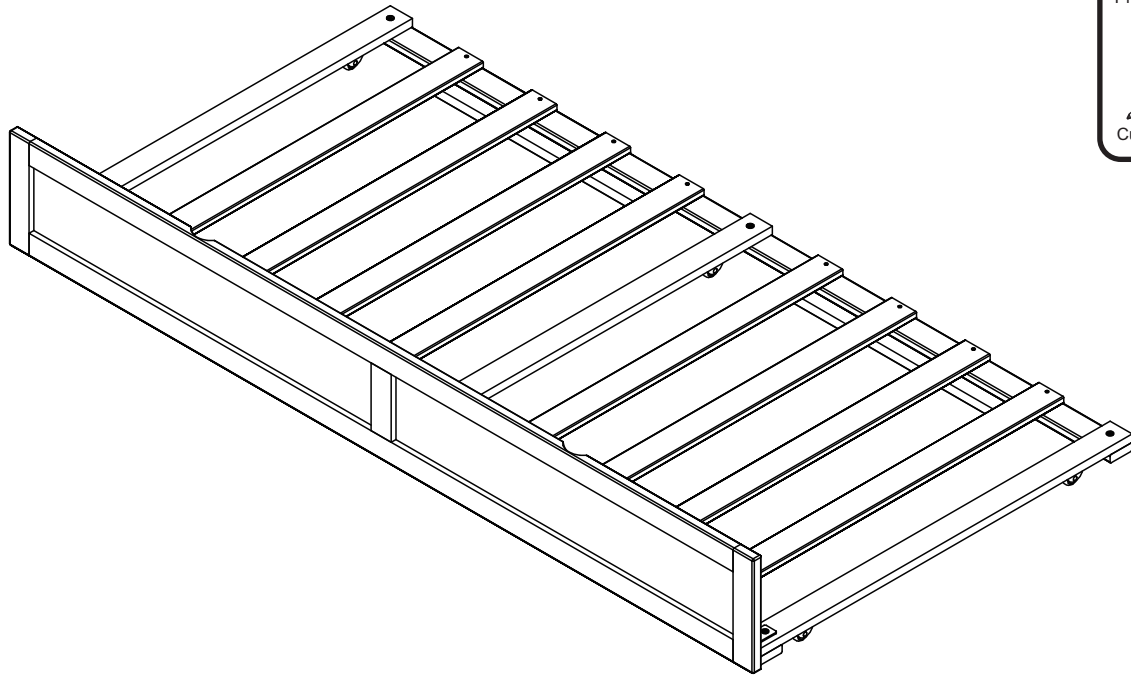

HARDWARE

NOTE: WE INCLUDE SPARE HARDWARE IN CASE DAMAGE OCCURS DURING ASSEMBLY.

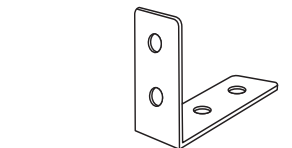
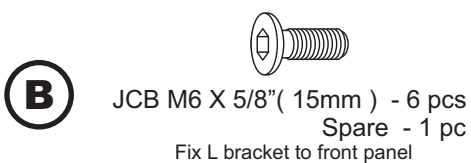
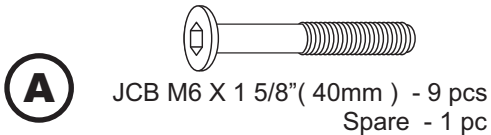

TWIN

PARTS LIST

- | | | | | | |
|----|-------------|-------|----|-----------------------|--------|
| 01 | HARDWARE | 1 BOX | 05 | LEFT, RIGHT, MID RAIL | 3 PCS |
| 02 | FRONT PANEL | 1 PC | 06 | SLAT KIT WITH WEBBING | 2 SETS |
| 03 | FRONT RAIL | 1 PC | | | |
| 04 | BACK RAIL | 1 PC | | | |

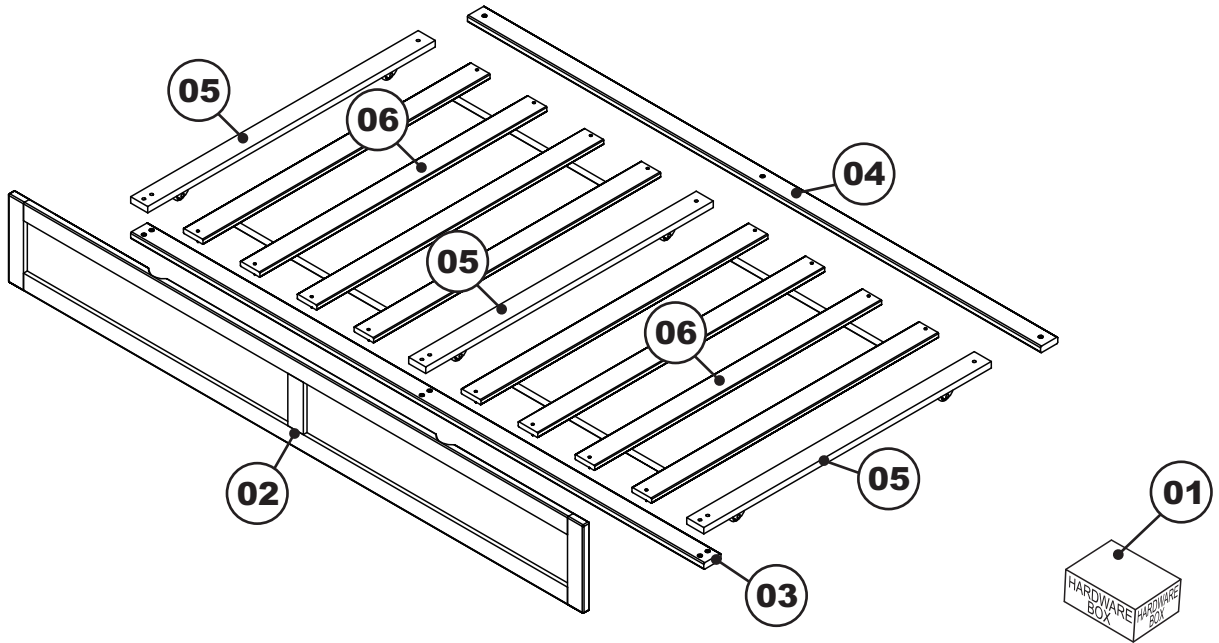

Step 1

Attach the left, right and mid rails (05) to the front rail (03) using L bracket (C) and JCB M6 X 1 5/8" (A). Attach left, right and mid rails (05) to the back rail (4) using JCB M6 X 1 5/8" (A). Tighten with the Allen wrench (E).

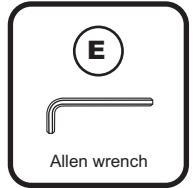
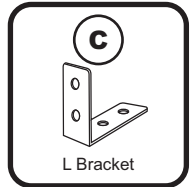
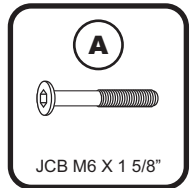
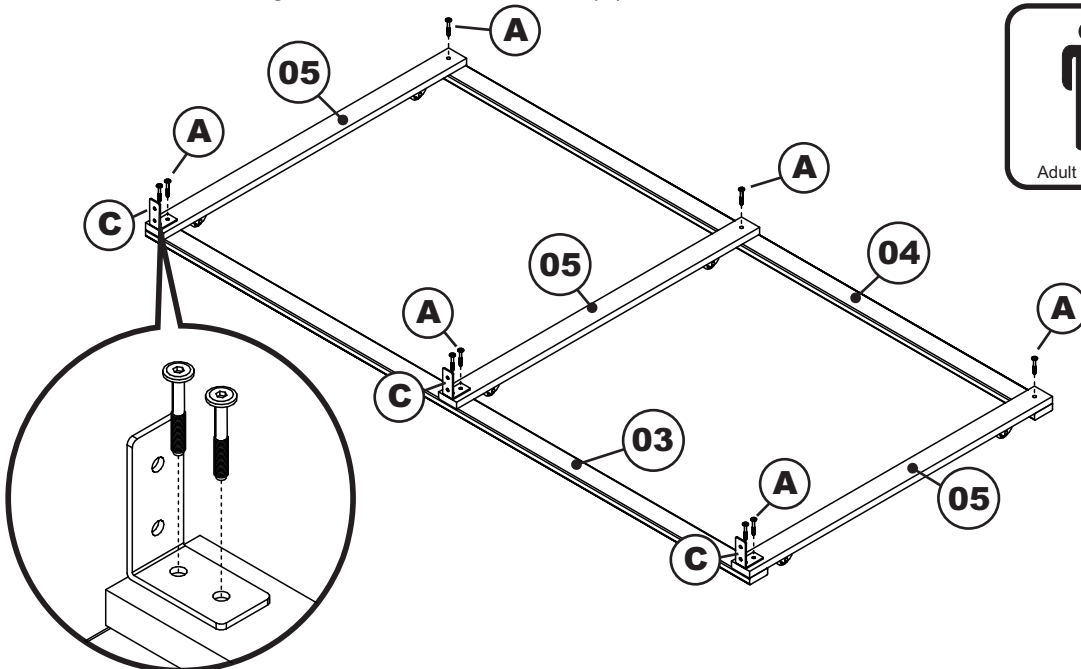

TWIN

Step 2

Attach the front panel (02) to the front rail (03) as shown, using JCB M6 X 5/8" (B). Tighten with the Allen wrench (E).

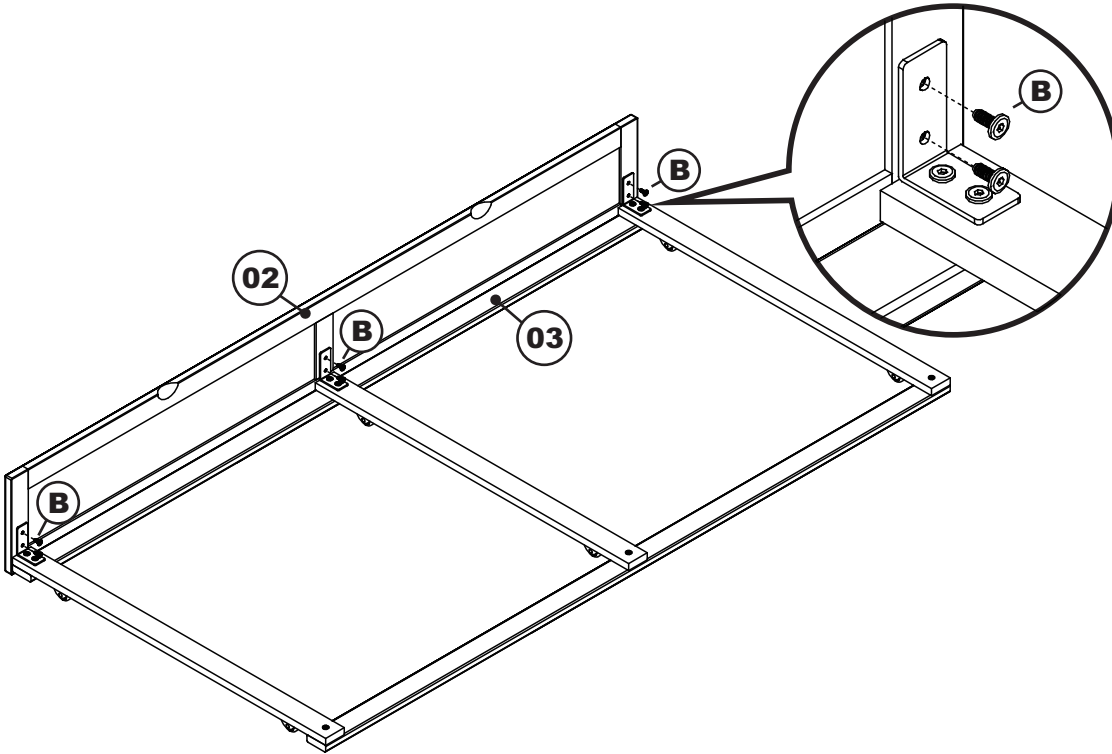

Adult assembly

B



JCB M6 X 5/8"

E



Allen wrench

Step 3

Lay the slat kits (06) webbing side down onto the rail assembly as shown. Attach using wood screw (D) and tighten with the Phillips head screw driver. (customer supplied)

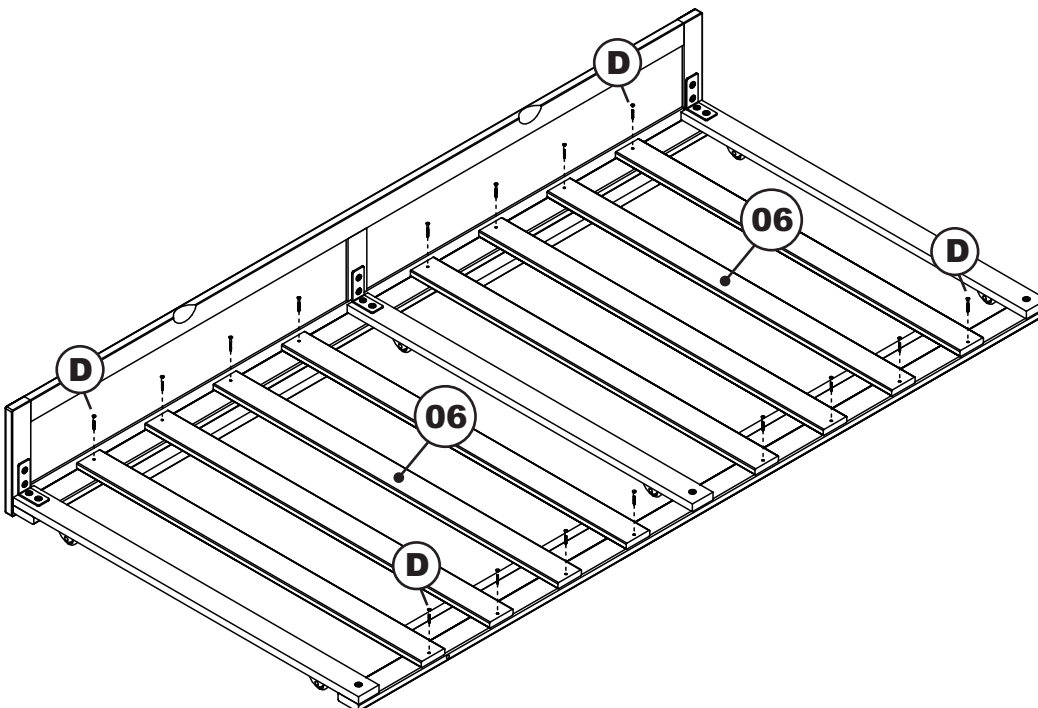

Adult assembly

D

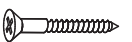

Wood screw

Phillips screwdriver



Customer supplied

TWIN

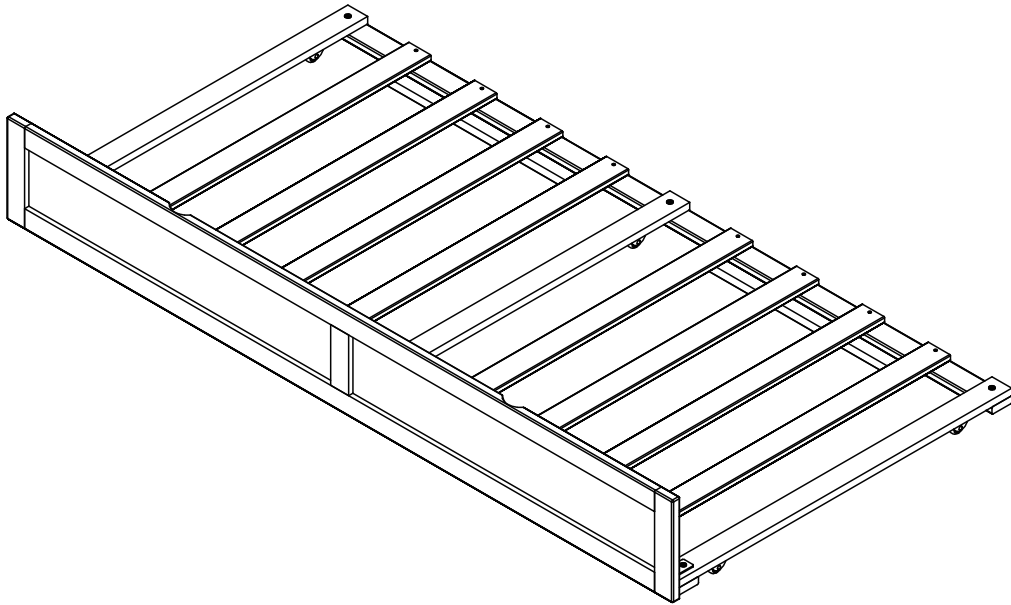

Congratulations!

Your Trundle bed is now ready for use.
We recommend that you periodically check that all screws are tight
and all parts are secure to ensure lasting safety.

Step 4

Lastly, Insert Trundle bed to the bed as shown below.

