

WOOD LATERAL FILE CABINETS



This is the original instruction, please read all manual instructions carefully before operating. We reserves a clear interpretation of our user manual. The appearance of the product shall be subject to the product you received. Please forgive us that we won't inform you again if there are any technology or software updates on our product.

SAFETY INSTRUCTIONS

WARNING:

Read this material before using this product. Failure to do so may result in serious injury.

Assembly precautions

1. Assemble only according to these instructions. Improper assembly may create hazards.
2. Wear ANSI-approved safety goggles and heavy-duty work gloves during assembly.
3. Keep the assembly area clean and well-lit.
4. Keep bystanders out of the area during assembly.
5. Do not assemble if tired or when under the influence of alcohol, drugs or medication.
6. The product capabilities apply to properly and completely assembled products only.
7. Assemble on a flat, level, hard and smooth surface capable of safely supporting the Wood lateral file cabinets.
8. For additional information regarding the parts listed in the following pages, please refer to the Assembly Diagram of this manual. Unwrap and separate all parts in a clean work area.









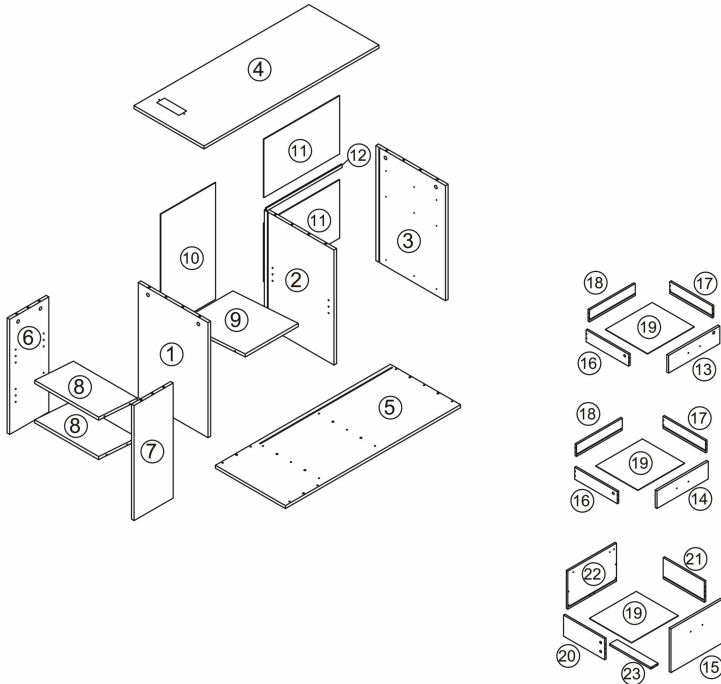









Use precautions

1. DO NOT SIT OR STAND ON THIS ITEM.
2. This product is not a toy. Do not allow children to play with or near this item.
3. Do not exceed specified weight capacities.
4. Use only on a flat, level, hard, and smooth surface that can safely support a fully loaded Wood lateral file cabinets.
5. Use as intended only.
6. Inspect before every use; do not use if parts are loose or damaged.

SAVE THIS MANUAL

PARTS LIST



A  A2 A1 x10	B  B2 B1 x12	C  x22	D  x13	E  x12	F  x3	G  x6
H  x1	I  3*16 x4	J  x5	K  DR CR CL DL x3	L  x2	M  x12	
N  3.5*35 x12	O  3*14 x12	P  3.5*14 x52	Q  x1	R  x22		

ASSEMBLY STEP

1

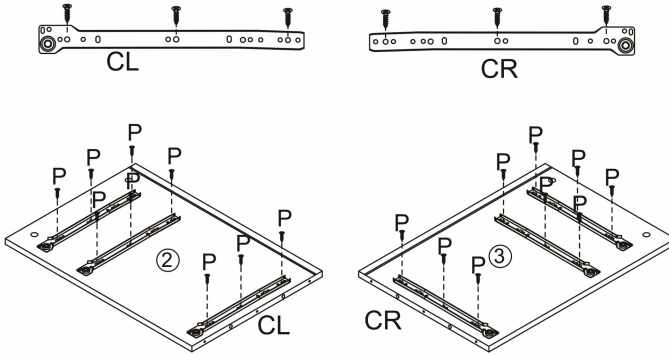

K(CL)*3
K(CR)*3
P*18

2

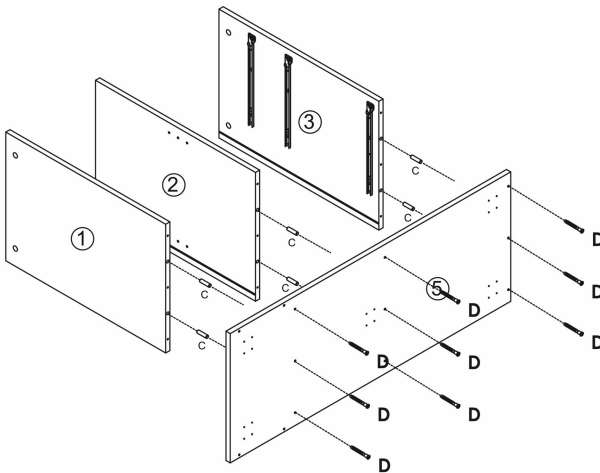

C*6
D*9

3

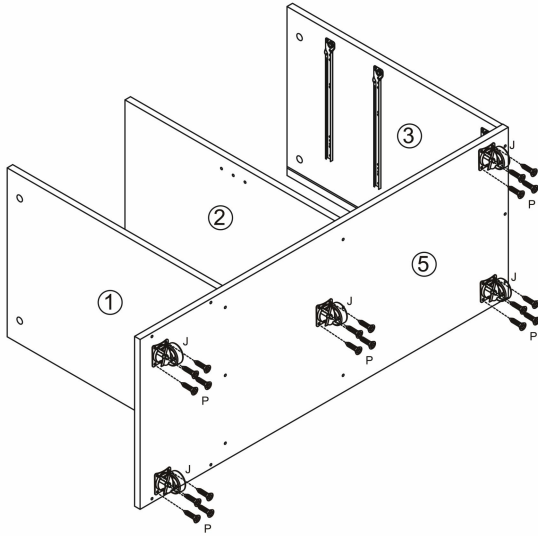

J*5
P*20

4

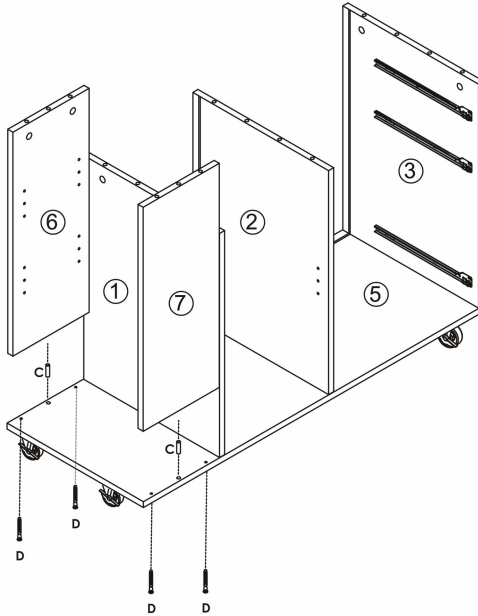

C*2
D*4

5

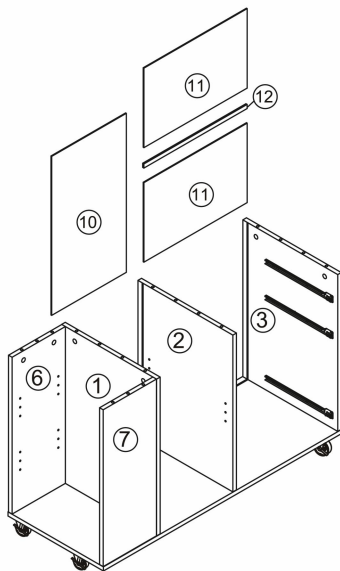

6

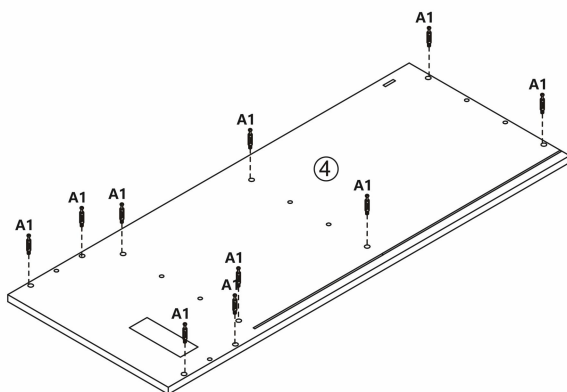

A1*10

7

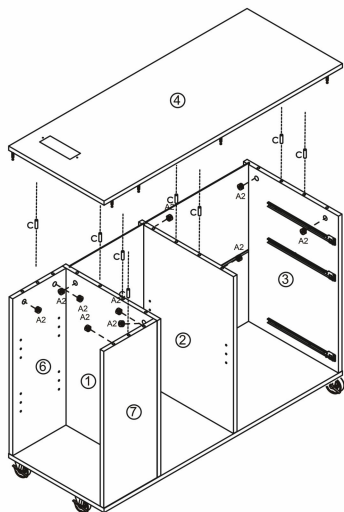

A2*10
C*8

8

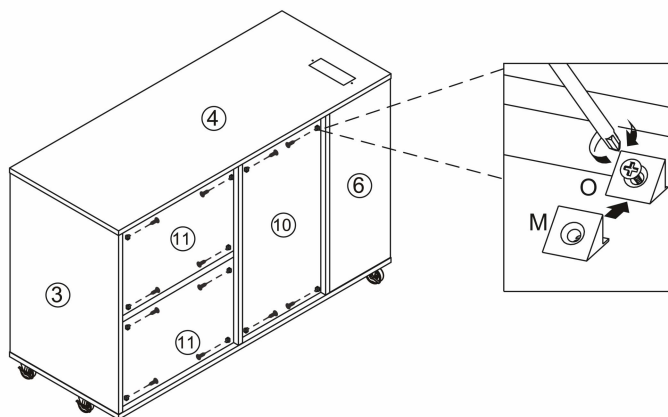

M*12
O*12

9

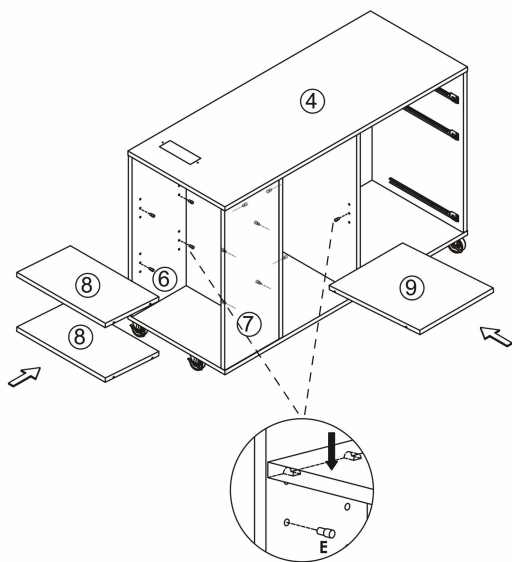

E*12

10

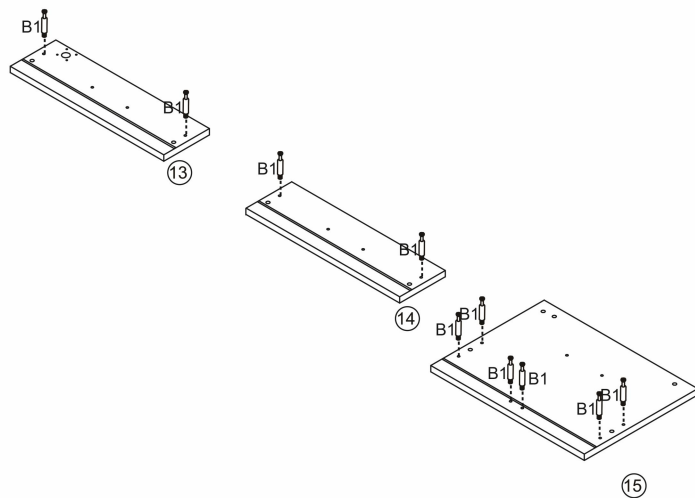

B1*10

11

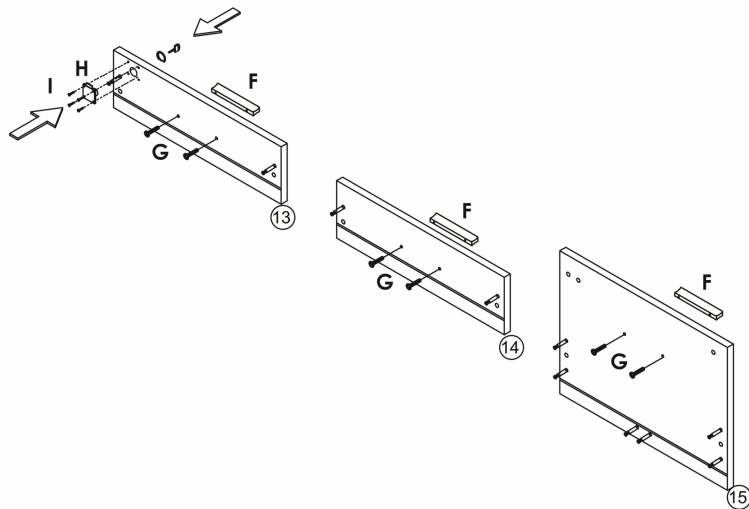

F*3
G*6
H*1
I*4

12

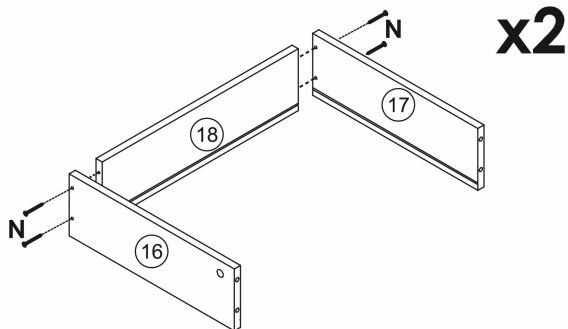

N*8

13

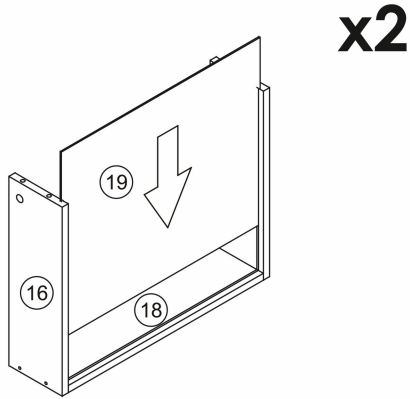

14

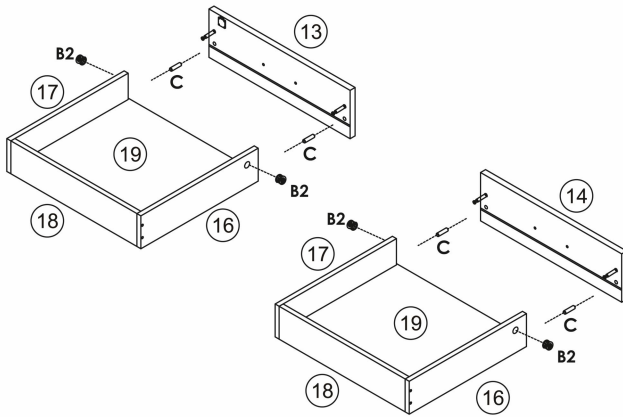

B2*4
C*4

15

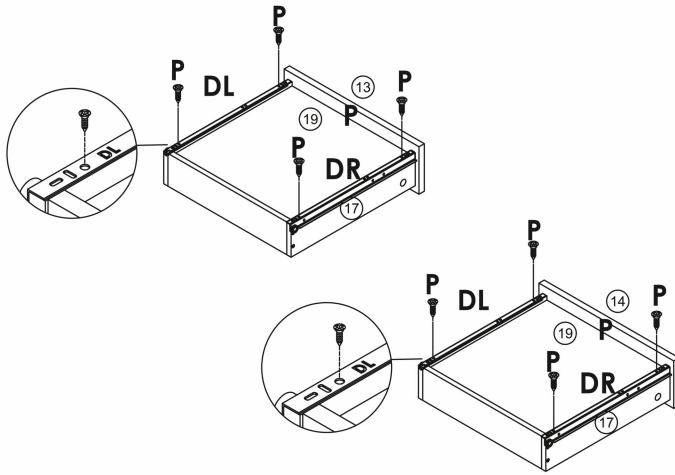

$K(DL)*2$
 $K(DR)*2$
 $P*8$

16

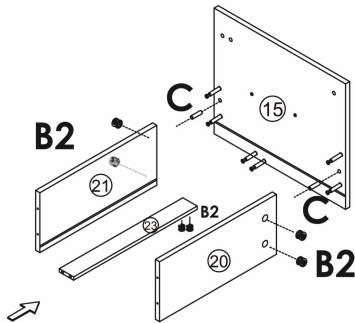

$B2*6$
 $C*2$

17

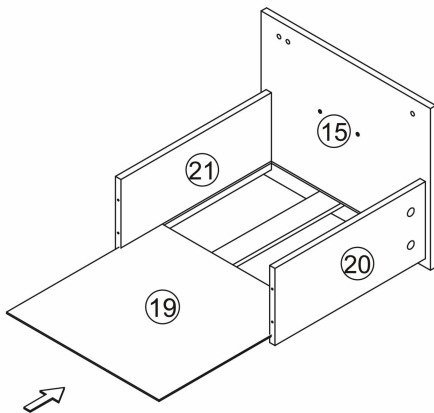

18

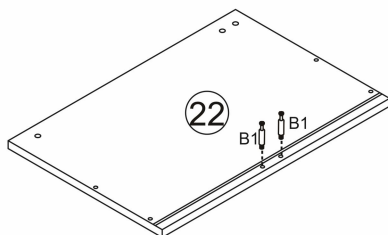

B1*2

19

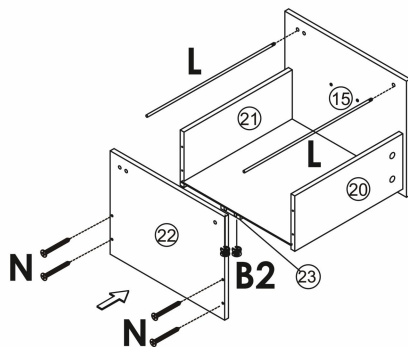

B2*2
L*2
N*4

20

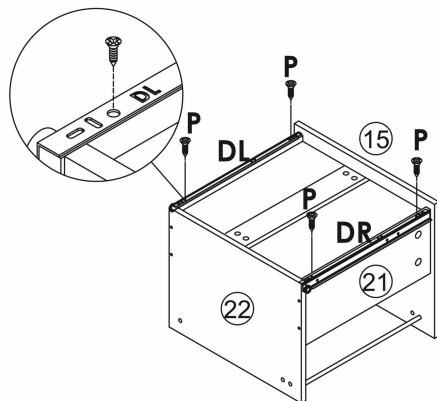

K(DL)*1
K(DR)*1
P*4

21

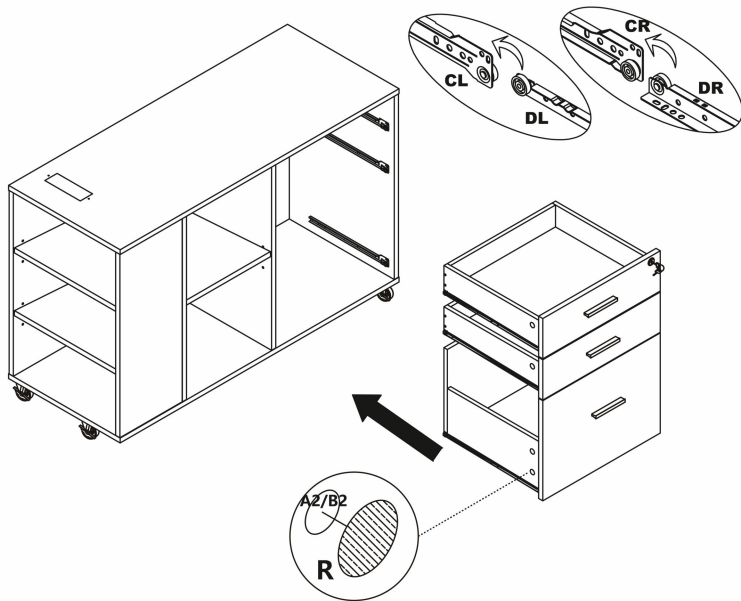

22

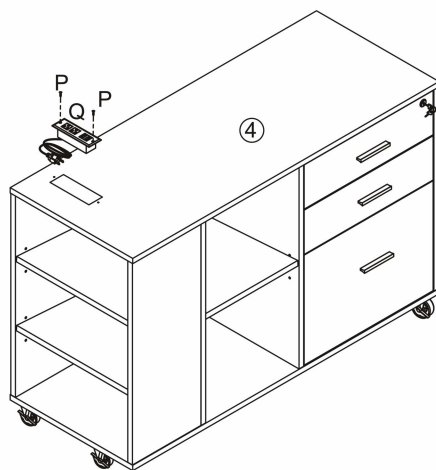

L*2
N*4

PRODUCT PARAMETER

Model	KLHW-05	KLHW-06
Power	AC125V 60HZ 12A (Via Power Strip)	
Safe Loading Weight	155 lbs	
Product Size	1000*400*650 mm	



This product is subject to the provision of European Directive 2012/19/EC. The symbol showing a wheeled bin crossed through indicates that the product requires separate refuse collection in the European Union. This applies to the product and all accessories marked with this symbol. Products marked as such may not be discarded with normal domestic waste, but must be taken to a collection point for recycling electrical and electronic devices.