

ASSEMBLY INSTRUCTION



45 min

HEADBOARD

Thank you for purchasing this quality product. Be sure to check all packing material carefully for small parts which may have come loose inside the carton during shipment. Identify and count all parts and compare with the parts list below.

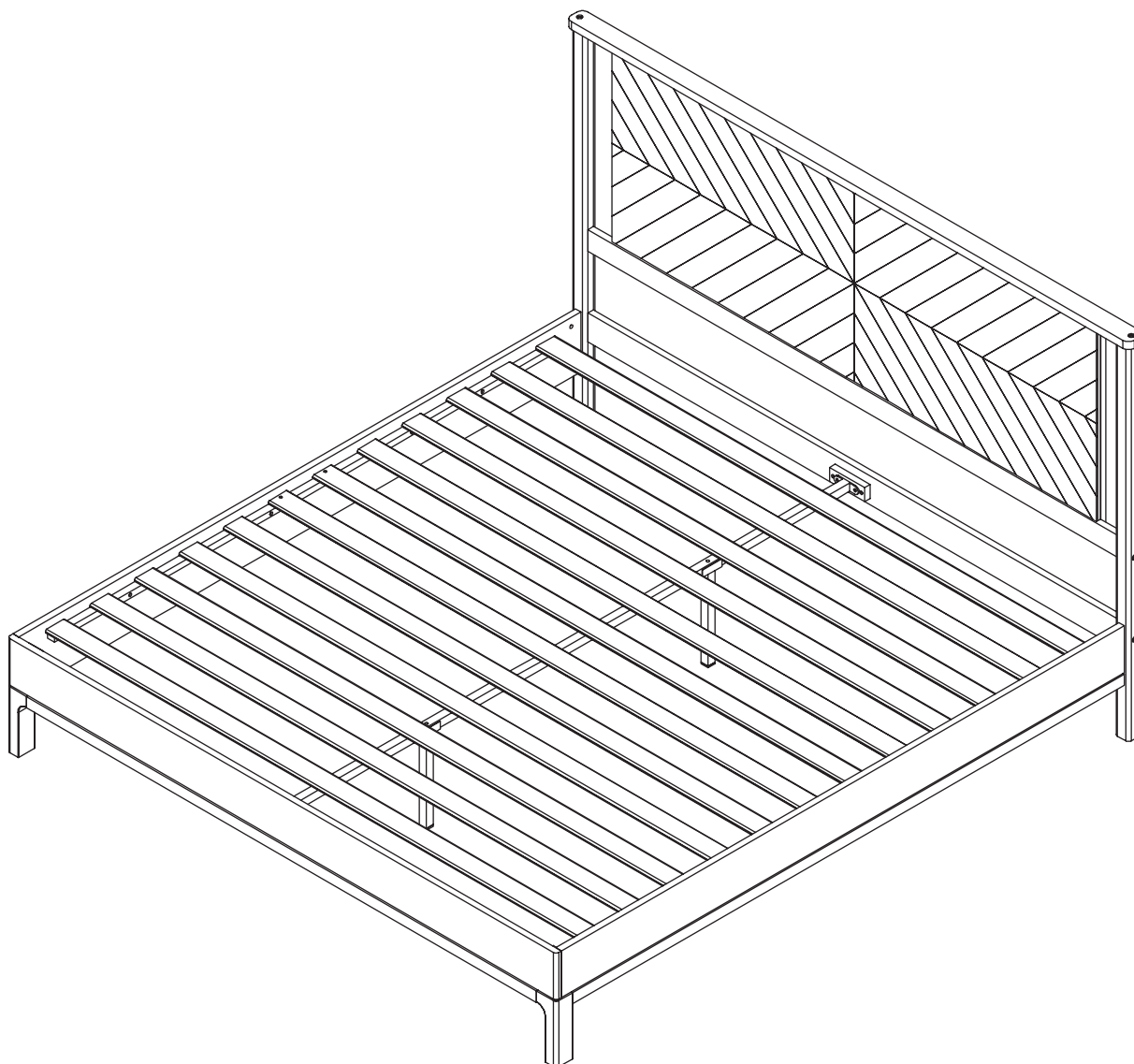



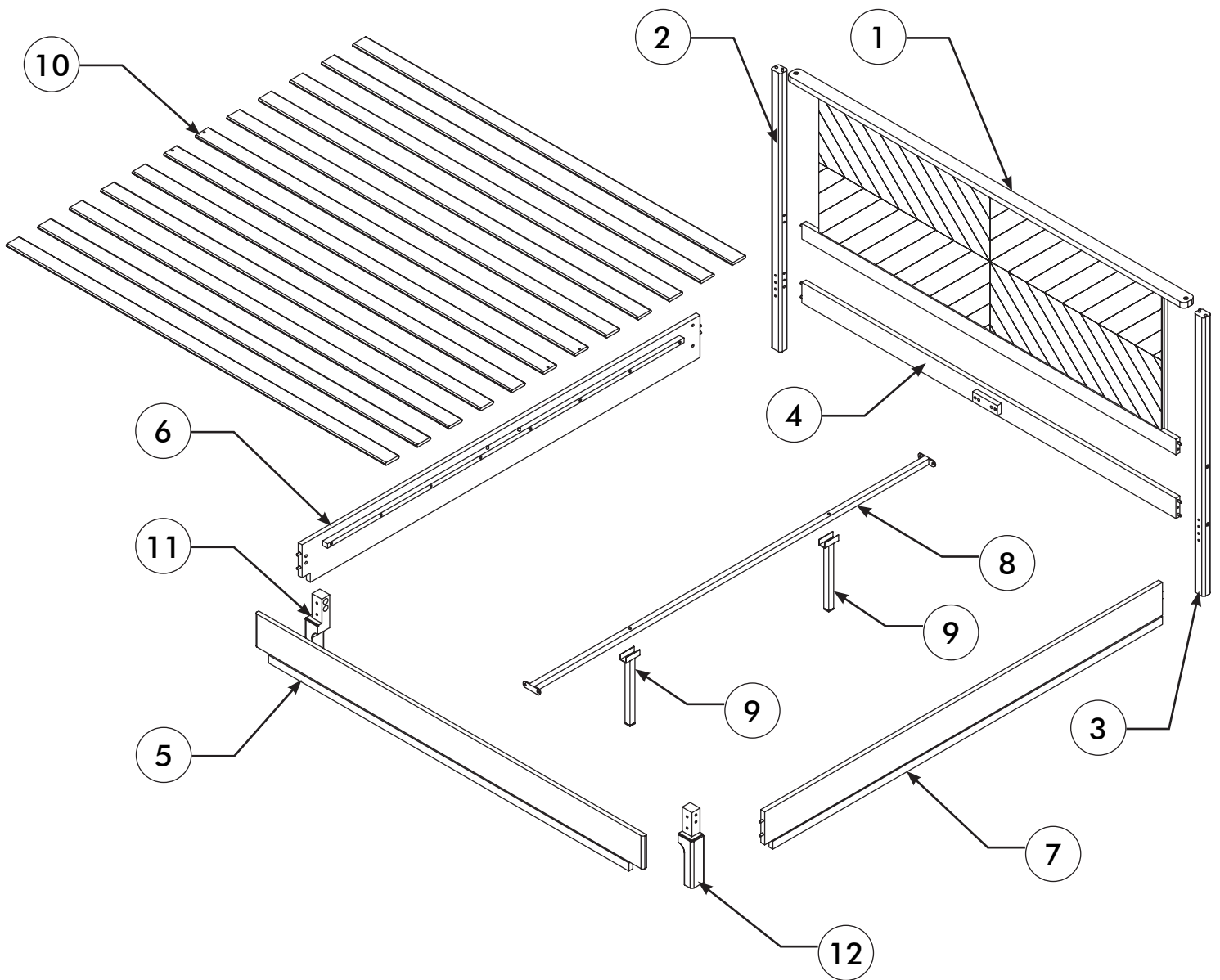



NOTICE: DO NOT use the power tools for assembly.
This can cause the bolts to be over tightened.
DO NOT over tighten hardware, damage may occur.







THE PART LAYOUT

HARDWARE

HARDWARE			
A	M6 x 90		8 PCS
B	DOWEL NUT		8 PCS
C	M8 x 50		8 PCS
D	M8 x 35		4 PCS
E	M8 x 20		4 PCS
F	2 x Ø8.5 x Ø22		14 PCS
G	ALLEN KEY		1 PC

STEP 1

LAY THE PANEL FACE DOWN ON THE GROUND BEFORE ASSEMBLING.



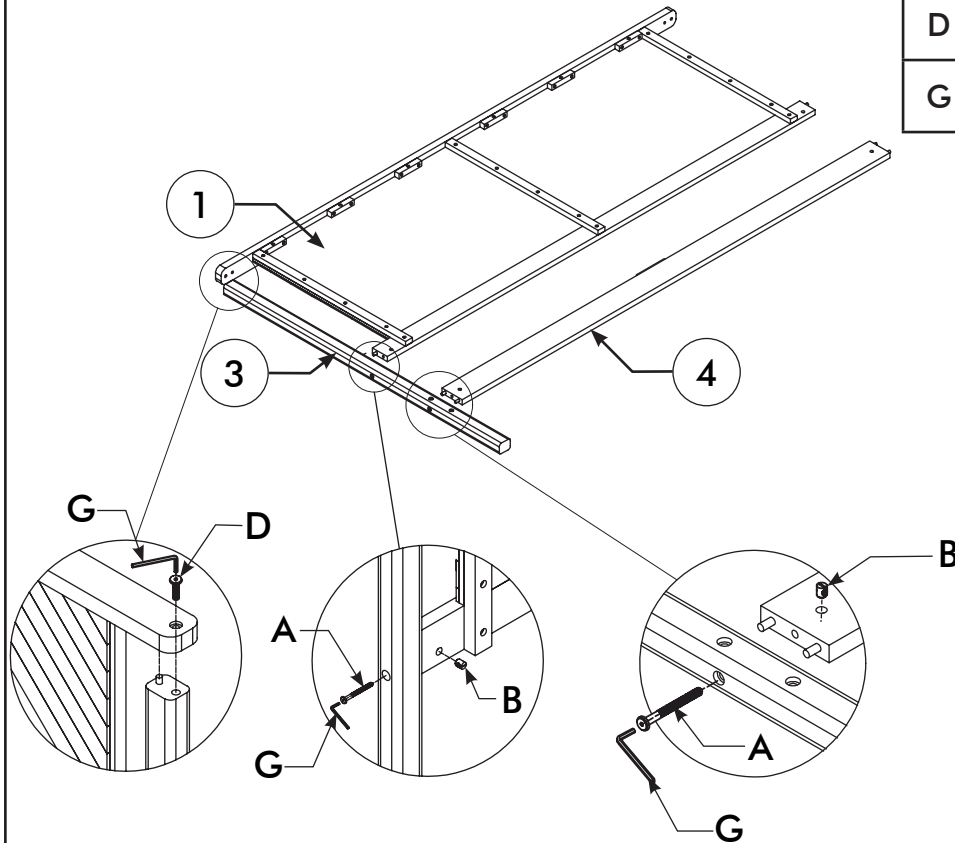

A	M6 x 90		2 PCS
B	DOWEL NUT		2 PCS
D	M8 x 35		1 PCS
G	ALLEN KEY		1 PC



NOTICE: When assembling, place all the parts on a soft, clean, and flat surface such as a carpet to prevent scratches

STEP 2

LAY THE PANEL FACE DOWN ON THE GROUND BEFORE ASSEMBLING.

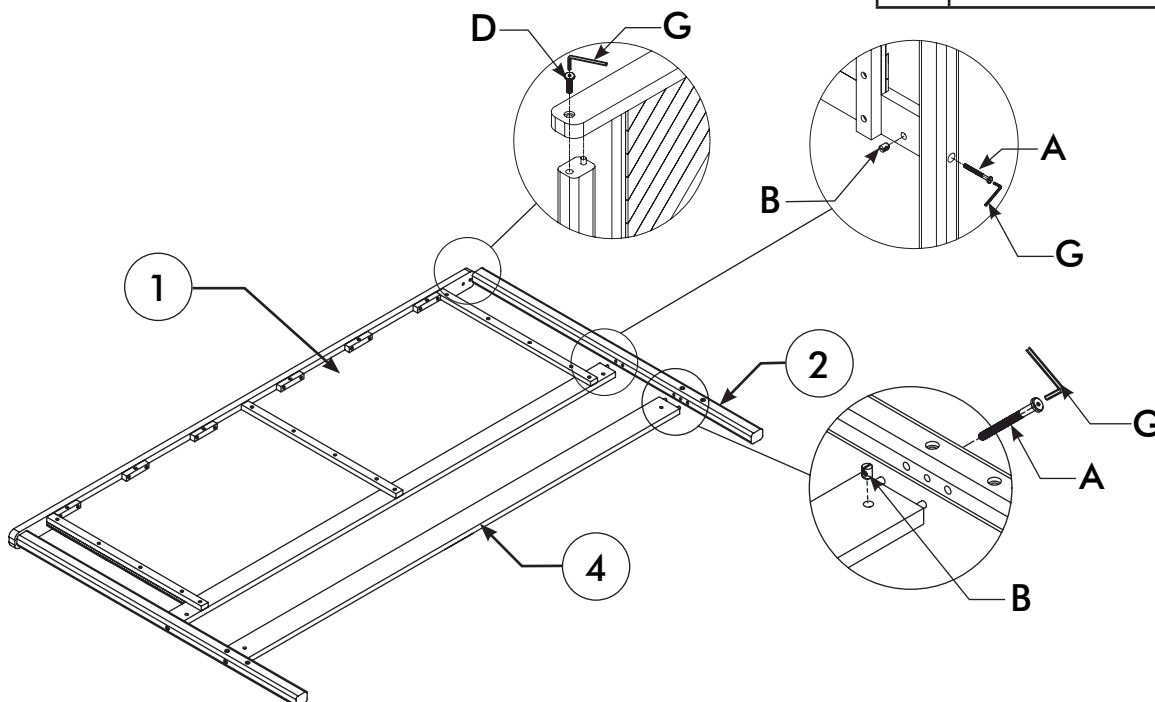

A	M6 x 90		2 PCS
B	DOWEL NUT		2 PCS
D	M8 x 35		1 PCS
G	ALLEN KEY		1 PC



NOTICE: When assembling, place all the parts on a soft, clean, and flat surface such as a carpet to prevent scratches

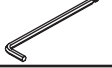

STEP 3

LAY THE FOOT BOARD PANEL FACE DOWN ON THE GROUND BEFORE ASSEMBLING.

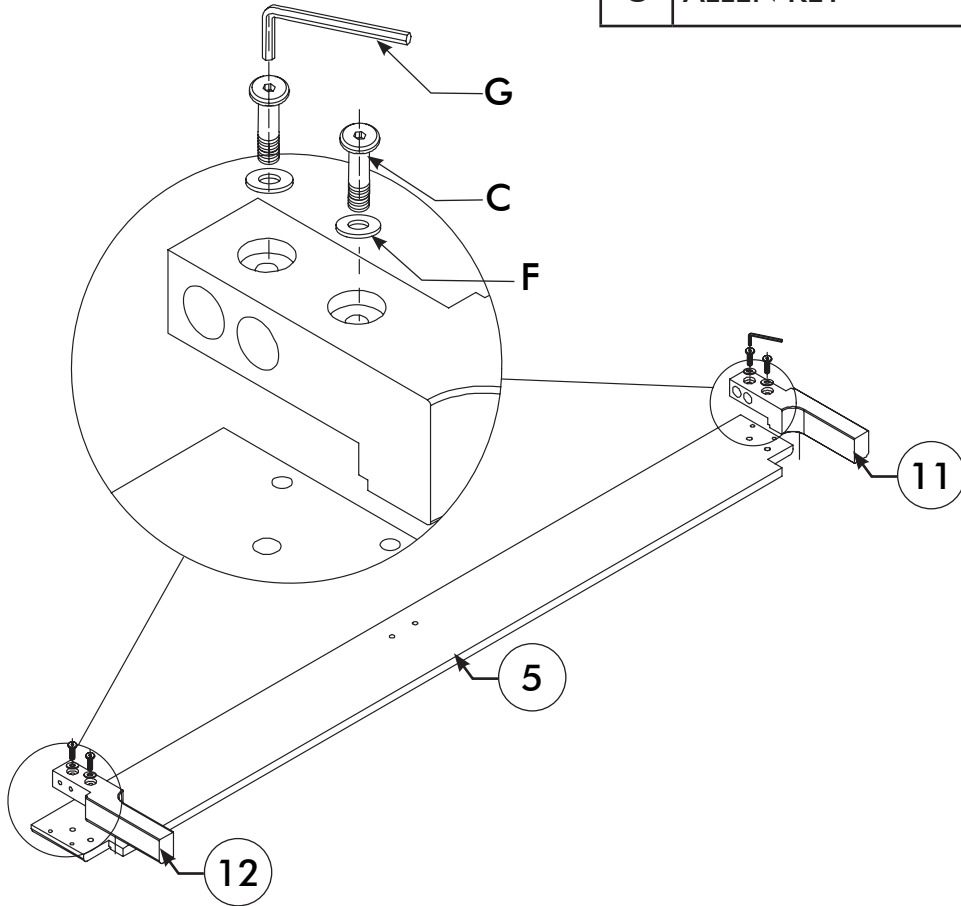
C	M8 x 50		4 PCS
F	2 x Ø8.5 x Ø22		4 PCS
G	ALLEN KEY		1 PC



STEP 4

C	M8 x 50		4 PCS
F	2 x Ø8.5 x Ø22		4 PCS
G	ALLEN KEY		1 PC

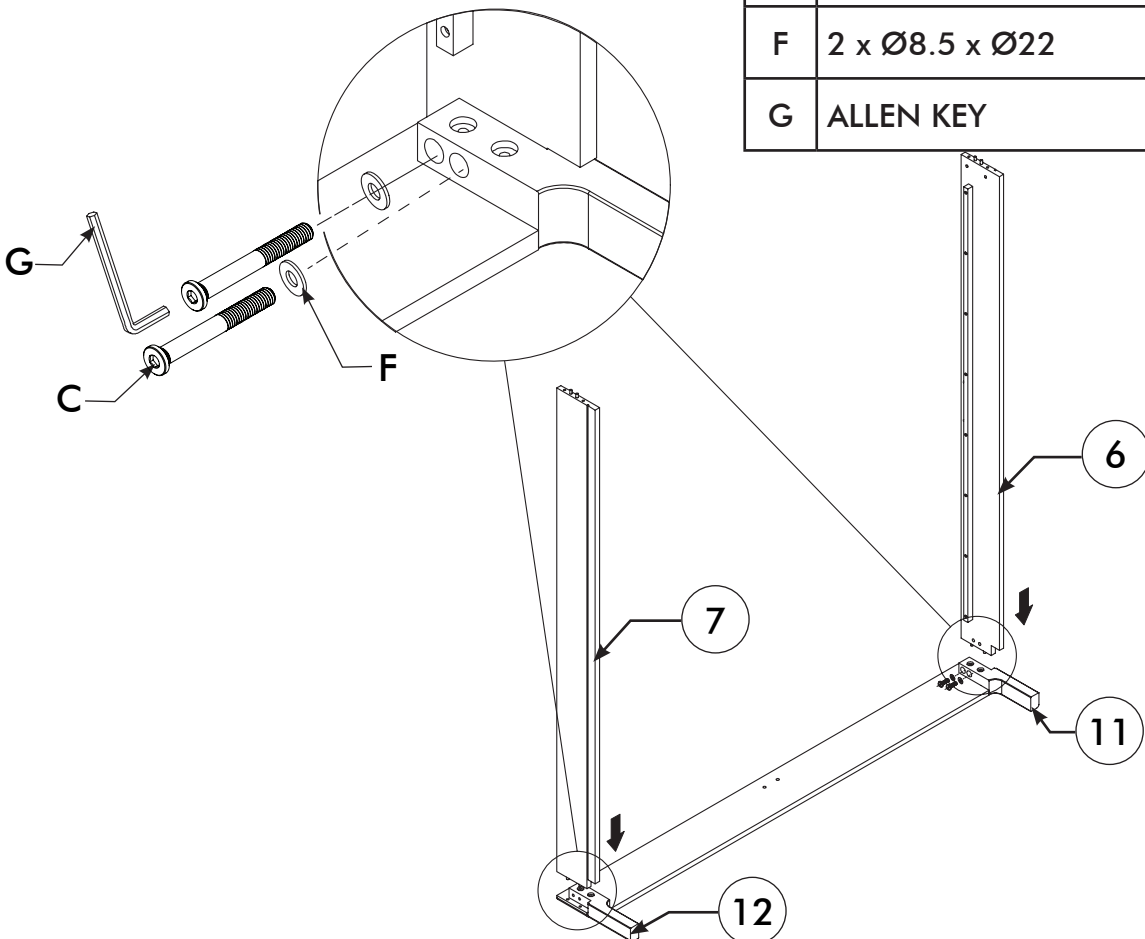

NOTICE: When assembling, place all the parts on a soft, clean, and flat surface such as a carpet to prevent scratches

STEP 5

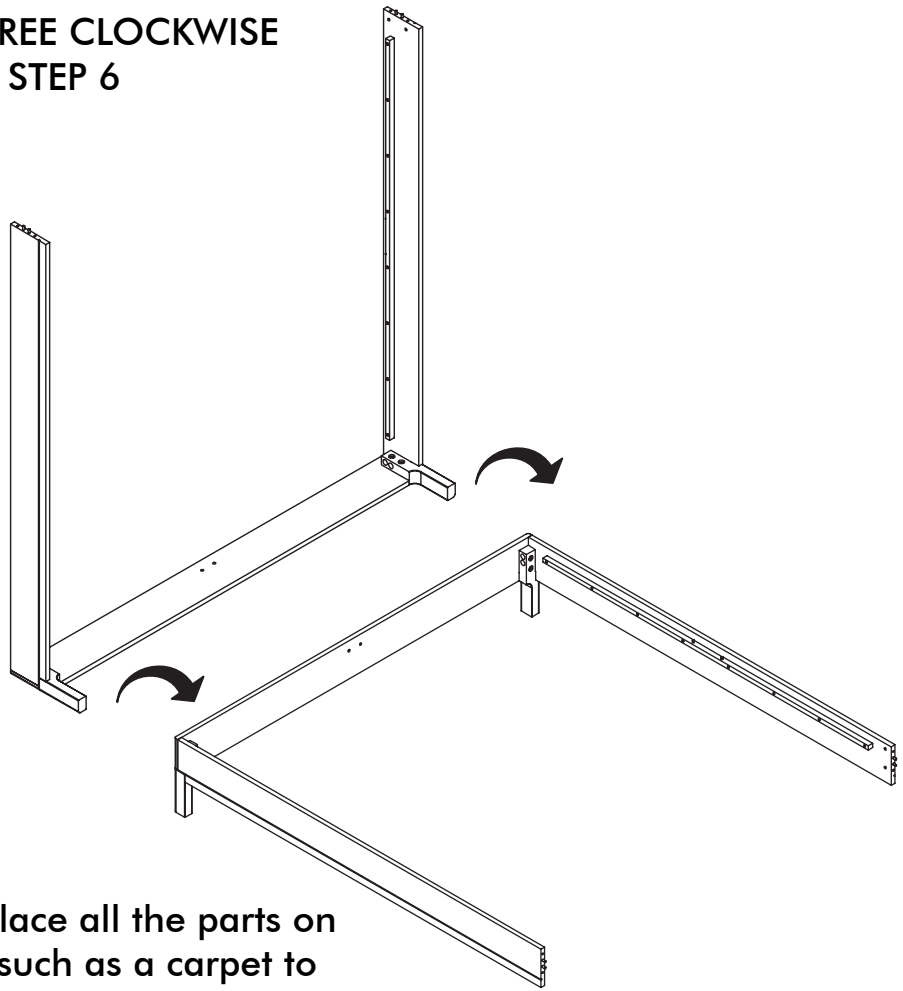

**ROTATE THE FRAME 90 DEGREE CLOCKWISE
FOR PREPARATION STEP 6**



NOTICE: When assembling, place all the parts on a soft, clean, and flat surface such as a carpet to prevent scratches

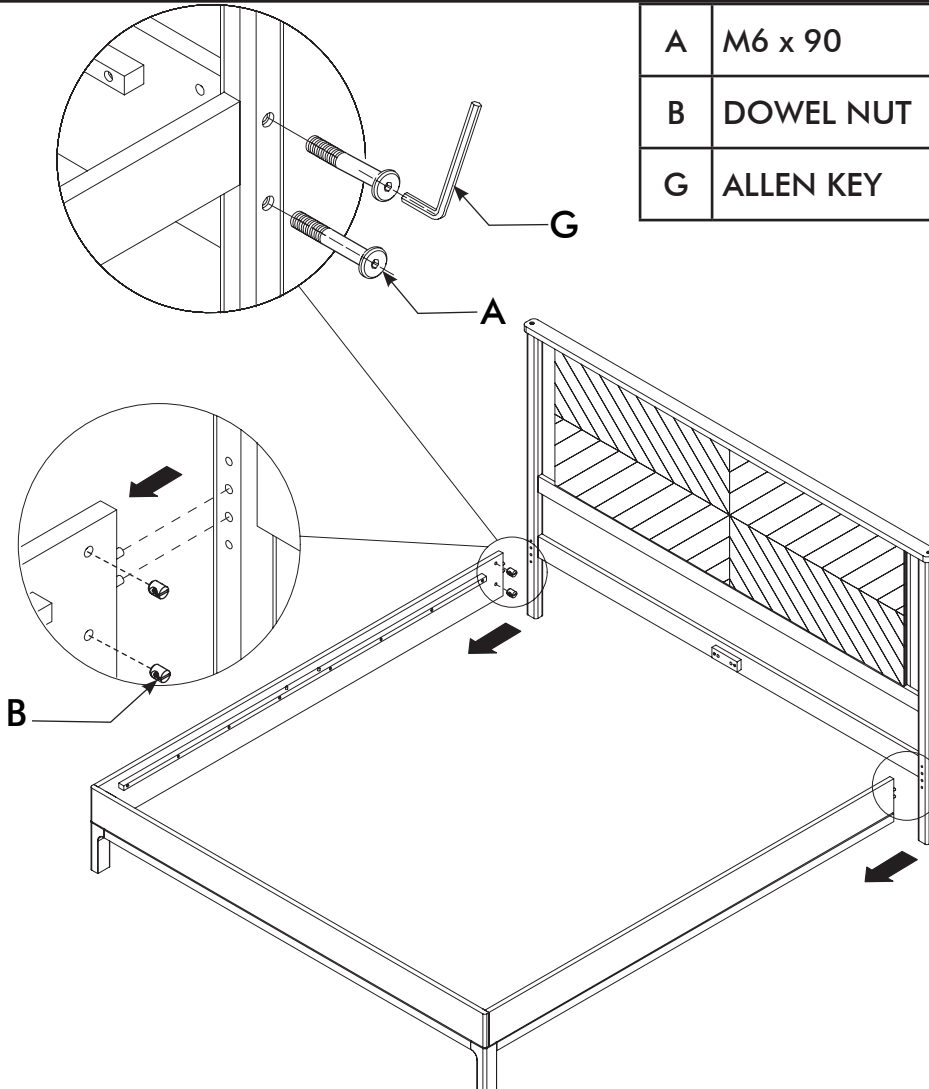

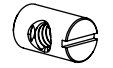
STEP 6



A	M6 x 90		4 PCS
B	DOWEL NUT		4 PCS
G	ALLEN KEY		1 PC

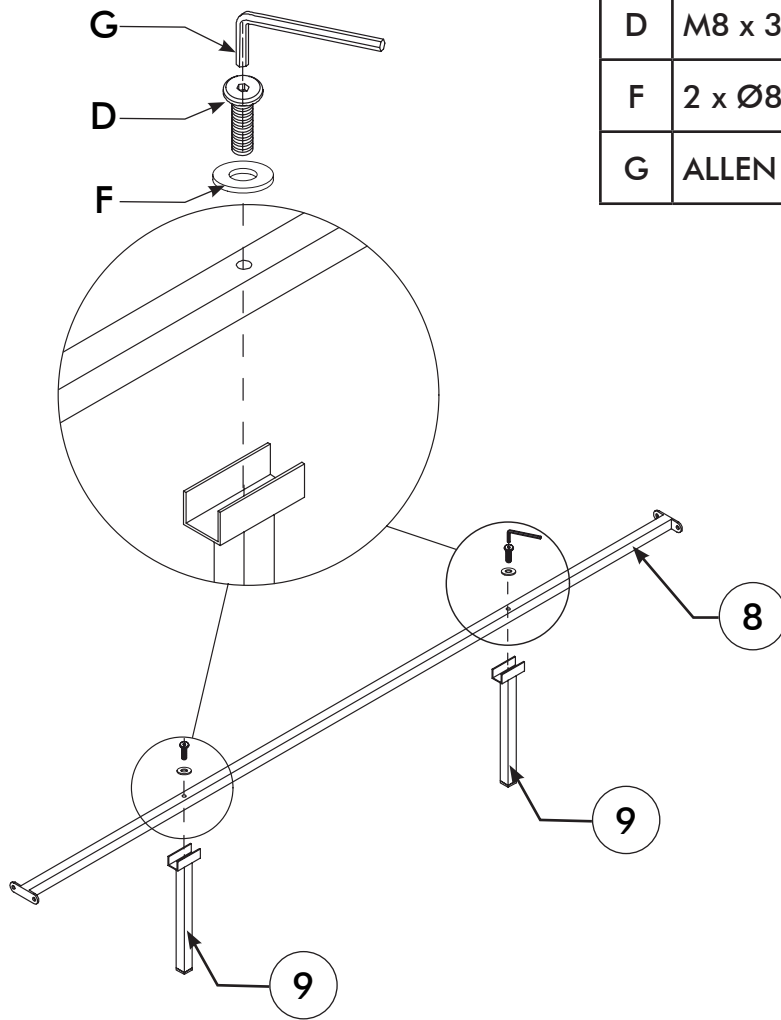

STEP 7

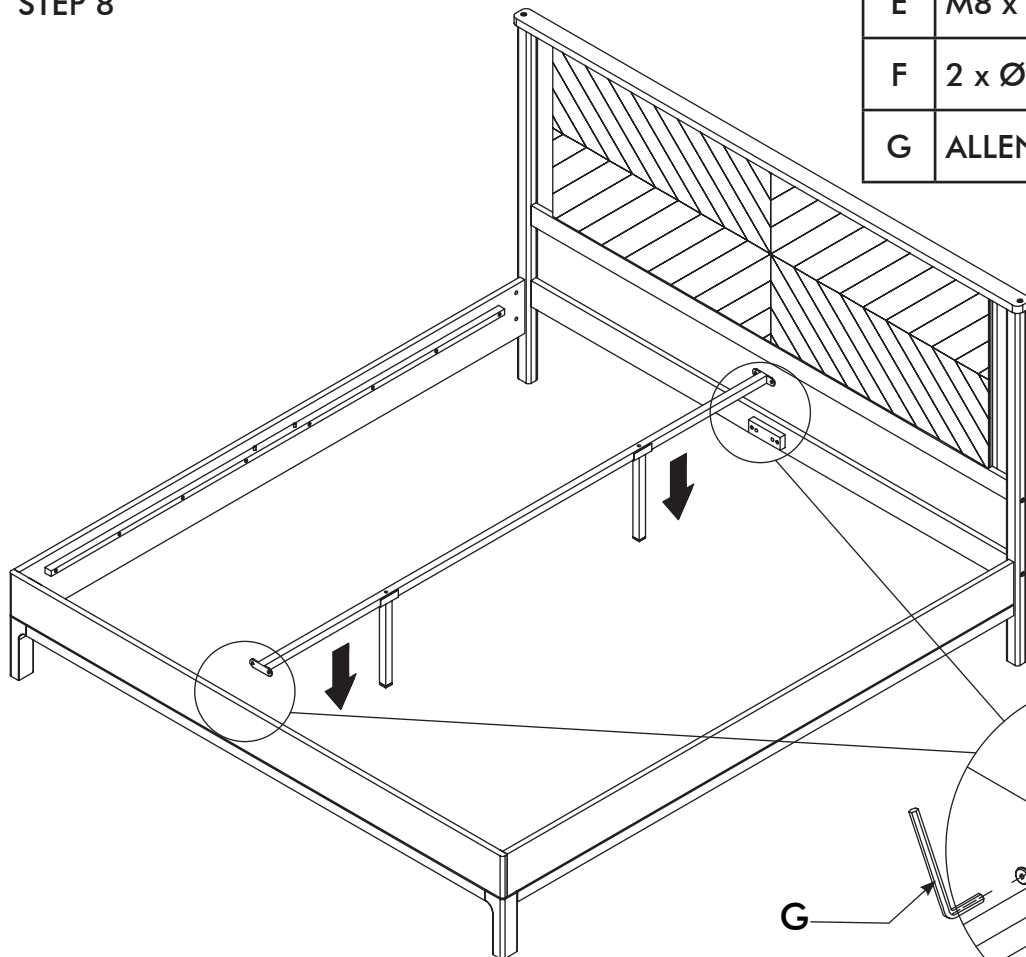

D	M8 x 35		2 PCS
F	2 x Ø8.5 x Ø22		2 PCS
G	ALLEN KEY		1 PC

STEP 8



E	M8 x 20		4 PCS
F	2 x Ø8.5 x Ø22		4 PCS
G	ALLEN KEY		1 PC

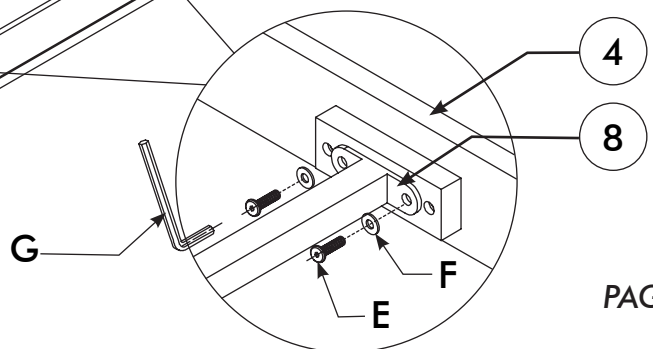

STEP 9

ATTACH THE SLATS TO BED, HOLE ON SLAT
ALIGN WITH DOWEL.

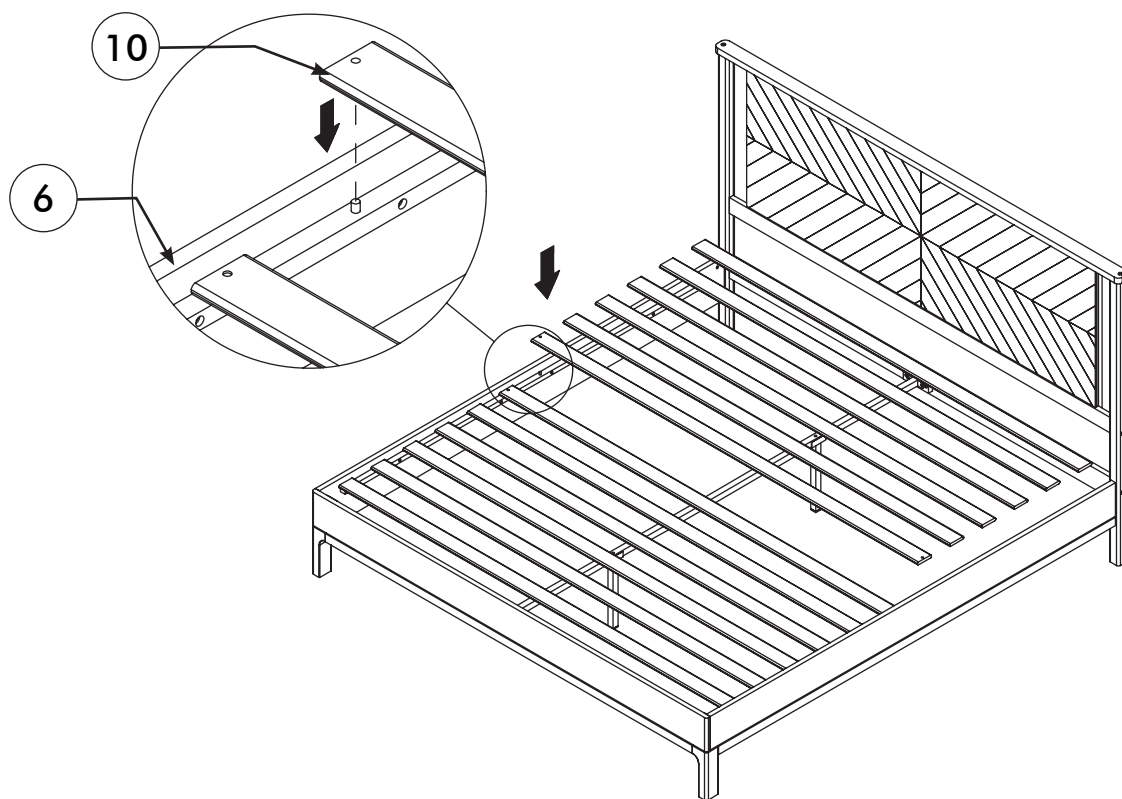

FINISH

