

## Assembly Instructions

### 7-Piece Steel Dining Set-Chairs

Model # 138C136PK

Customer Service Department:

Telephone Message Center: (833) 807-3550

Email Customer Service at: [customer-service@linyaoutdoor.com](mailto:customer-service@linyaoutdoor.com)

Hours of Operation: Please feel free to leave a telephone message or email us at any time. Follow up will be conducted as soon as possible.

## Part List

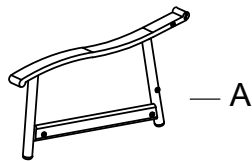

-A

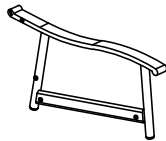

-B

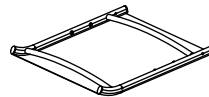

-C

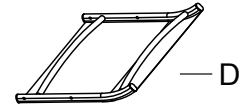

-D

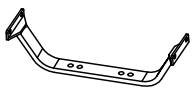

-E

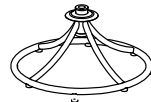

-F

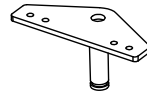

-G



-H

Part	Description	Quantity
A	Right arm	6
B	Left arm	6
C	Chair seat panel	6
D	Chair back panel	6

Part	Description	Quantity
E	U-bar	6
F	Chair base	6
G	T-swivel	6
H	Connecting tube	6

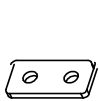

-AA



-BB

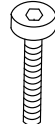

-CC

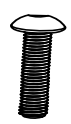

-DD



-EE



-FF



-GG



-HH



-II



-JJ



-KK



-LL



-MM

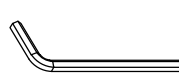

-NN



-OO

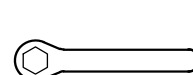

-PP



-QQ



-RR

Part	Description	Quantity
AA	Washer plate	12
BB	Bolt (M6x30)	48
CC	Bolt (M6x55)	12
DD	Bolt (M8x24)	24
EE	Bolt (M8x38)	24
FF	Washer (D6)	60
GG	Washer (D8)	48
HH	Lock washer (D8)	48
II	Bolt cap (M6)	60

Part	Description	Quantity
JJ	Bolt cap (M8)	24
KK	Nut (M8)	24
LL	Nut cap (M8)	24
MM	Bolt cap (M8)	24
NN	Wrench (M6)	1
OO	Wrench (M8)	1
PP	Wrench (M8)	2
QQ	Plastic washer	24
RR	Bushing	6

⚠ Above is a list of all parts and hardware to use. Please check it before assembling, and if there is any missing or damaged, please feel free to contact us.

1

Place the chair seat panel (C) on a flat, smooth surface. Note, be sure to use a blanket or cardboard to keep from scratching the item.

Align the U-bar (E) to the chair seat panel (C).

Attach the U-bar (E) to the chair seat panel (C) with the plastic washers (QQ), the washers (GG), the lock washers (HH) and the bolts (DD) using the wrench (OO).

**Caution: Please don't fully tighten before all the bolts are in place.**

Cover all the bolts (DD) with the bolt caps (MM) after all the bolts fully tightened.

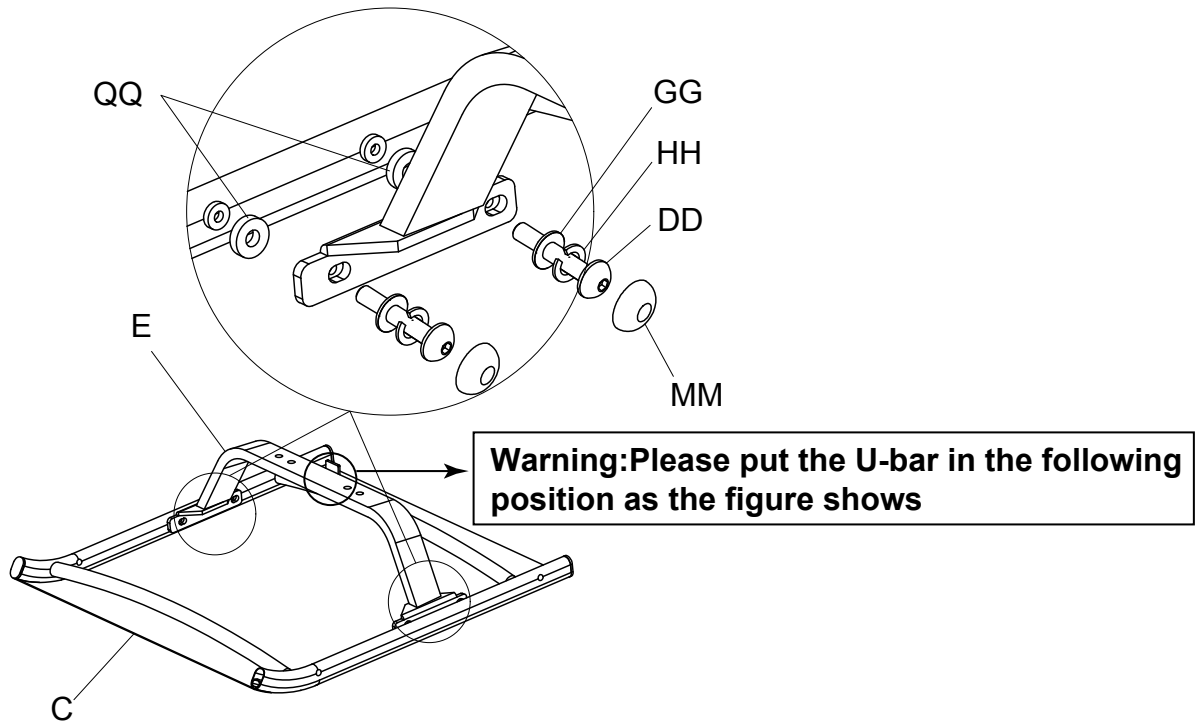

2

Align the connecting tube (H) to the right arm (A) and the left arm (B).

Attach the connecting tube (H) to the right arm (A) and the left arm (B) with the washers (FF), the bolts (CC) using the wrench (NN). **Caution: Please don't fully tighten before all the bolts are in place.**

Cover all the bolts (CC) with the bolt caps (II) after all the bolts fully tightened.

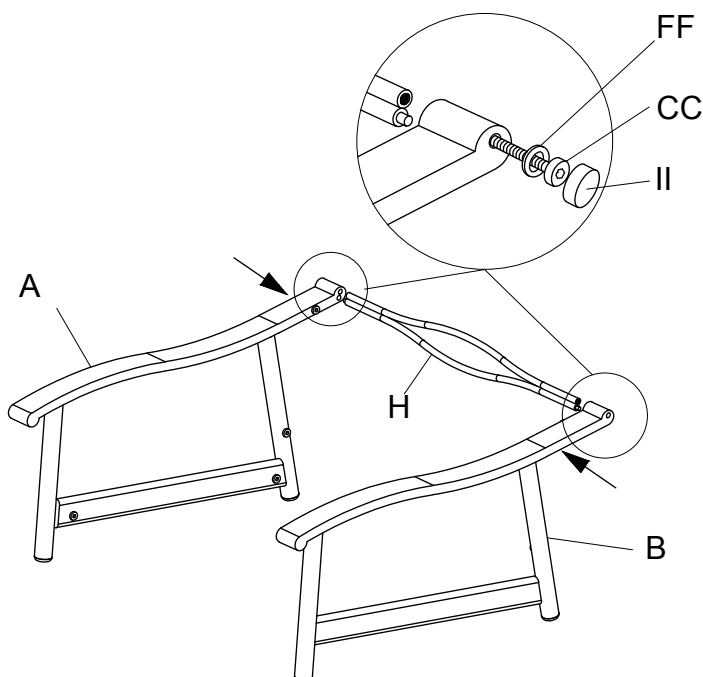

3

Align the chair seat panel (C) and the chair back panel (D) to the right arm (A) and the left arm (B).

Attach the chair seat panel (C) and the chair back panel (D) to the right arm (A) and the left arm (B) with the washers (FF), the bolts (BB) using the wrench (NN). **Caution: Please don't fully tighten before all the bolts are in place.**

Cover all the bolts (BB) with the bolt caps (II) after all the bolts fully tightened.

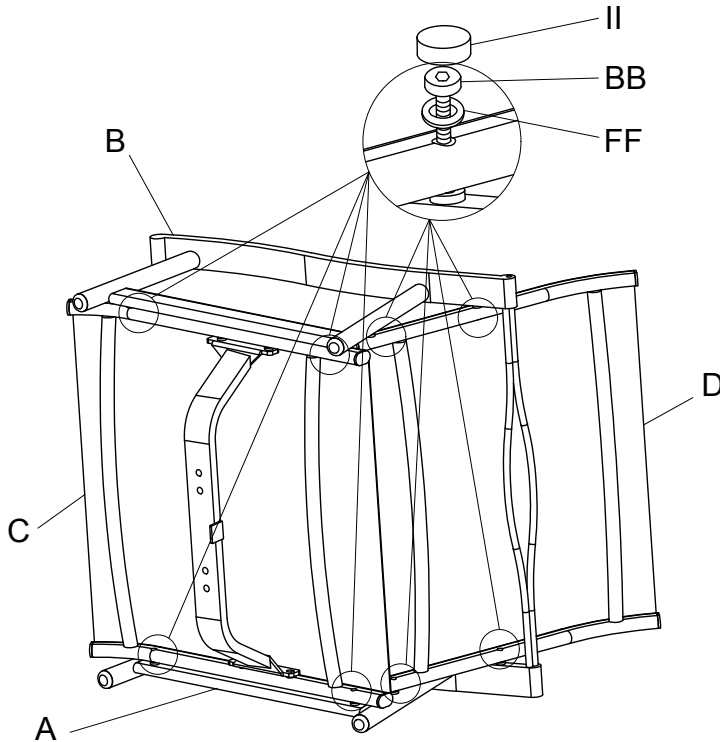

4

Align the T-swivel (G) to the U-bar (E).

Attach the T-swivel (G) to the U-bar (E) with the washer plates (AA) and the bolts (EE) above the U-bar (E) and also with the washers (GG), the lock washers (HH) and the nuts (KK) below the triangular plate of the T-swivel using the wrenches (PP). **Caution: Please don't fully tighten before all the bolts are in place.**

Cover all the bolts (EE) with the bolt caps (JJ) and cover all the nuts (KK) with the nut caps (LL) after all the bolts fully tightened.

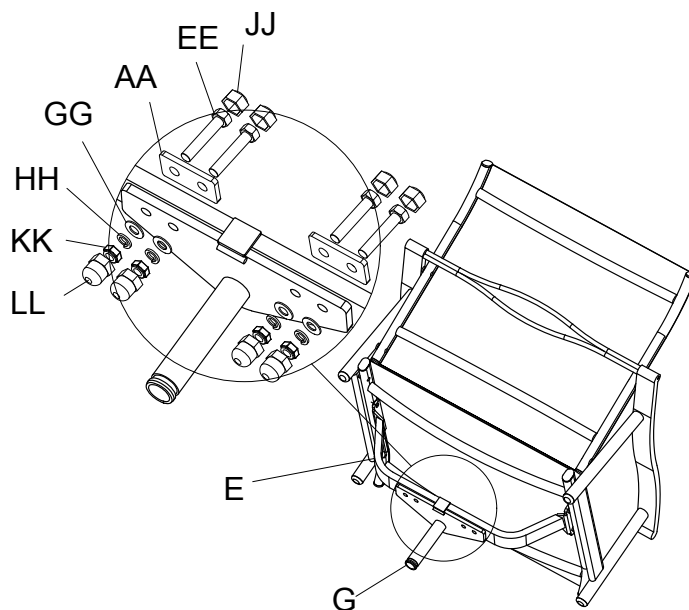

5

Place the chair base (F) on a flat, smooth surface. Note, be sure to use a blanket or cardboard to keep from scratching the item. Insert the bushing (RR) into the center of the chair base (F).

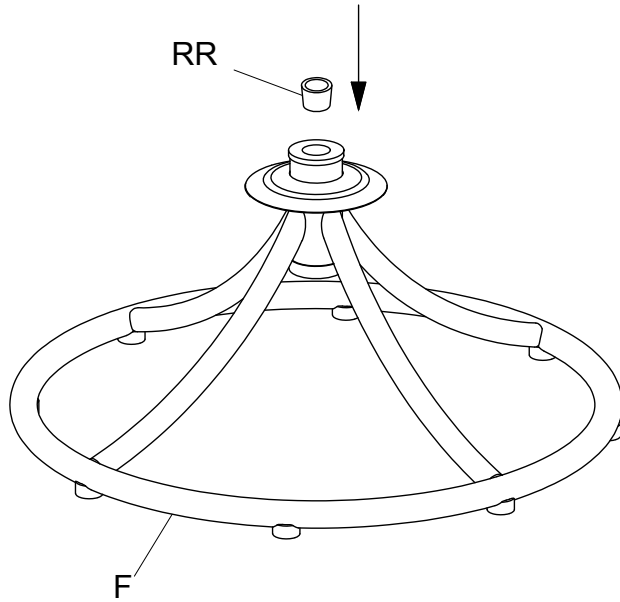

6

Turn the chair seat upright. Plug the shaft of the T-swivel into the center of the chair base until an audible click is heard. Repeat step 1 to step 6 for the other five chairs.

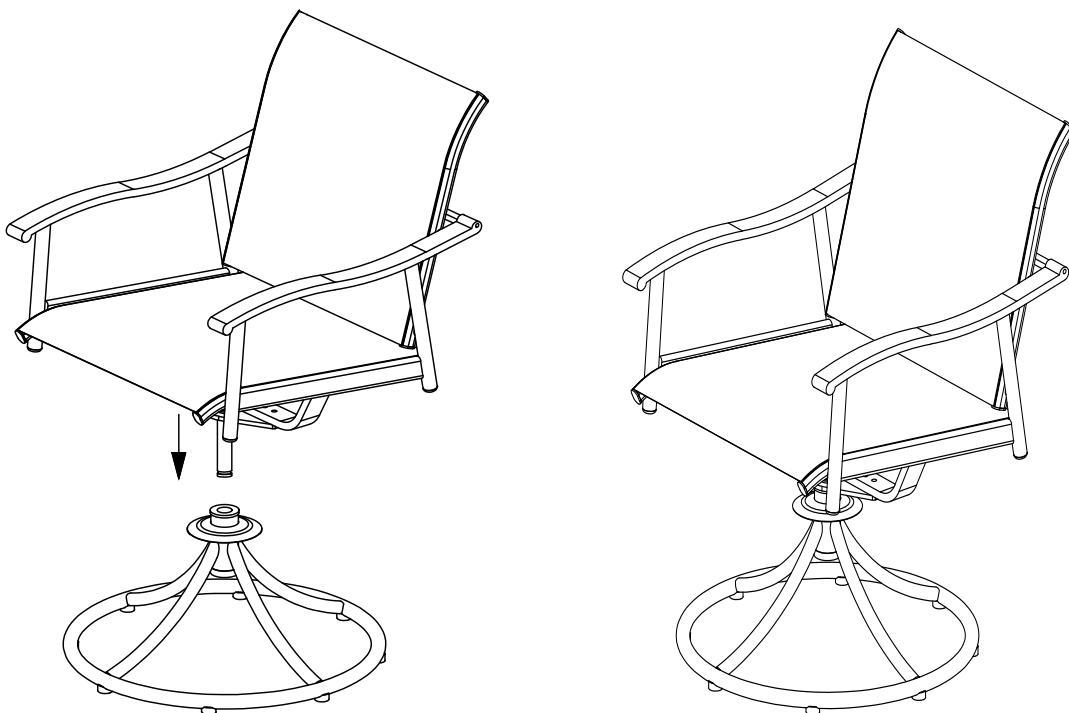



## Assembly Instructions

### 7-Piece Steel Dining Set-Table

Model # 138T61PK

Customer Service Department:

Telephone Message Center: (833) 807-3550

Email Customer Service at: [customer-service@linyaoutdoor.com](mailto:customer-service@linyaoutdoor.com)

Hours of Operation: Please feel free to leave a telephone message or email us at any time. Follow up will be conducted as soon as possible.

## Part List

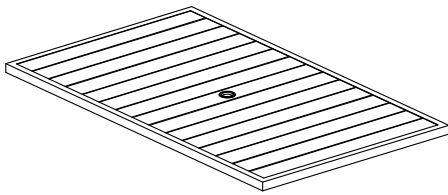

\_\_\_\_\_ A

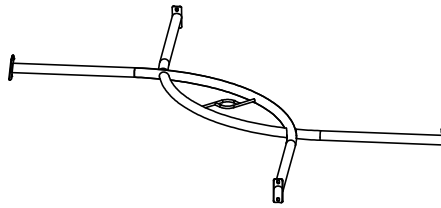

\_\_\_\_\_ B



\_\_\_\_\_ C

Part	Description	Quantity
A	Table top	1
B	Leg connector bracket	1
C	Table leg	4

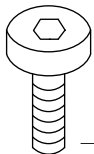

\_\_\_\_\_ AA



\_\_\_\_\_ BB



\_\_\_\_\_ CC

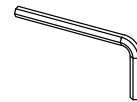

\_\_\_\_\_ DD

Part	Description	Quantity
AA	Bolt (M6x20)	16
BB	Washer	16
CC	Bolt cap	16
DD	Wrench	1

1

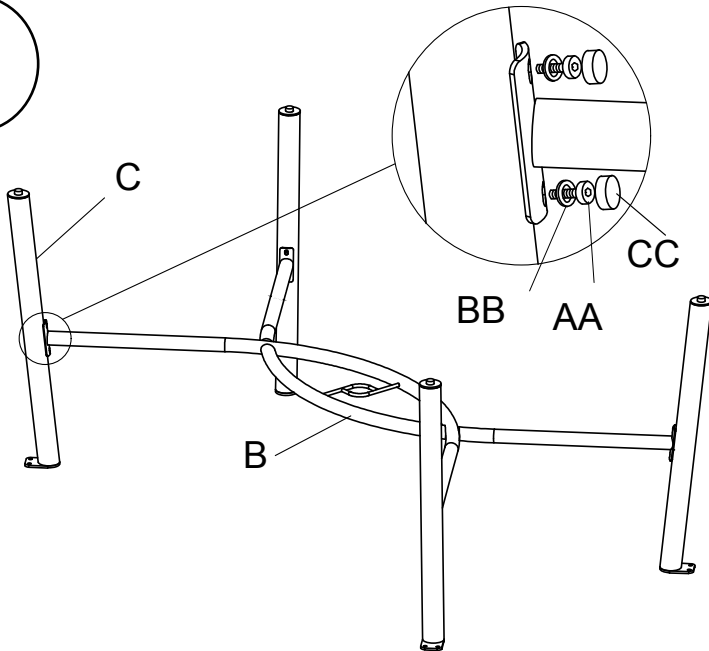

- Place the table leg (C) and the leg connector bracket (B) on a flat, smooth surface. Note, be sure to use a blanket or cardboard to keep from scratching the item.
- Align the table leg (C) to the leg connector bracket (B).
- Attach the table leg (C) to the leg connector bracket (B) with the washers (BB), the bolts (AA) using the wrench (DD). **Caution: Don't fully tighten before all the bolts are in place.**
- Cover all the bolts with the bolt caps (CC) after all the bolts are fully tightened.

2

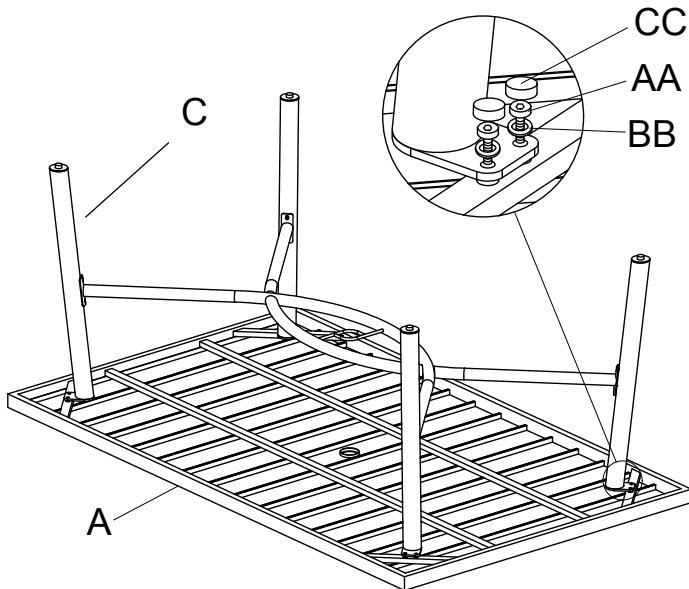

- Place the table top (A) upside down on a flat, smooth surface. Note, be sure to use a blanket or cardboard to keep from scratching the item.
- Align the table leg (C) to the table top (A).
- Attach the table leg (C) to the table top (A) with the washers (BB), the bolts (AA) using the wrench (DD). **Caution: Don't fully tighten before all the bolts are in place.**
- Cover all the bolts with the bolt caps (CC) after all the bolts are fully tightened.

3

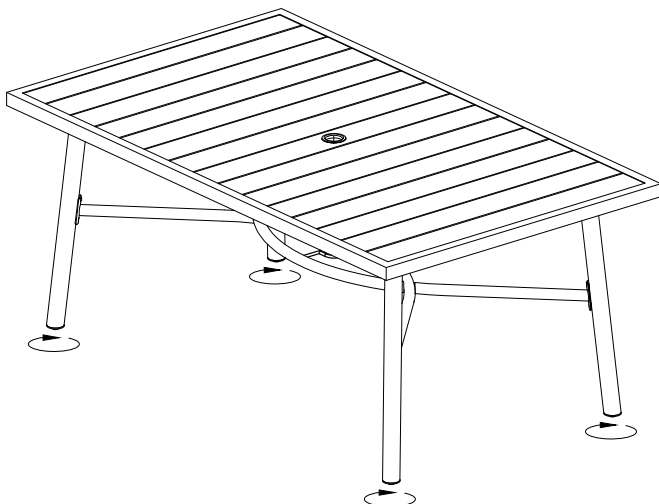

- Turn the table upright.
- Level the table with the foot glides if necessary