



Outdoor
Living Today

ASSEMBLY MANUAL

6x4 Space Master

With Double Door

Stock Code:

SM64-D-TG-CEDAR

SM64-D-TG-METAL

Version #1.6

Oct 3, 2025



CONTACT

ADDRESS

9393 287th Street,
Maple Ridge, British Columbia,
Canada V2W 1L1

PHONE & FAX

Toll Free: 1-888-658-1658

Fax:

ONLINE

Email: olmsupport@outdoorlivingtoday.com

Web: www.outdoorlivingtoday.com

What You Need to Know

Thank you for purchasing a 6x4 Space Master.

Please take the time to identify all the parts prior to assembly.

IMPORTANT INFORMATION

It is the sole responsibility of the customer to check with your local municipal or county by-laws before ordering this product to confirm it complies with building codes in your area.

If the product is elevated, any structural and building code requirements are solely the customer's responsibility, and should be abided by.

Snow load ratings vary by geographical location. If heavy or wet snowfall occurs, it is advisable to sweep snow off roof frequently. In areas with high or gusty wind conditions, it is advisable to install the structure securely to the ground.

Have a regular maintenance plan to ensure screws, doors, windows and parts are tightly affixed.

All structures purchased from Outdoor Living Today are covered for a period of one year for defects in manufacturing and workmanship. Costs incurred for customer installations are not included.

Failure to use supplied parts included in this kit could result in poor product performance and may void your warranty. Please contact Outdoor Living Today's Customer Toll Free Line if you plan to deviate from our written instructions.

Warranty

In the event of a missing or broken piece, please contact Outdoor Living Today Customer Support at olmsupport@outdoorlivingtoday.com within 30 days of the delivery of your purchase. It is our commitment to you to courier replacement parts, free of charge, within 10 business days of this notification. Replacement parts will not be provided free of charge after the 30 day grace period.

Customer agrees to hold Outdoor Living Today and any Authorized Dealers free of any liability for improper installation, maintenance and repair.

What to do Before my Shed Arrives?



Become familiar with this assembly manual and determine if you can complete the project yourself or will require a professional contractor.



One helper is recommended to assist in constructing your shed. It generally takes two people two days to assemble a shed. If you're hiring a contractor, their rate should be in line with that duration of work.



Clear the construction area and ensure a clear pathway for delivery when the freight company arrives. Remove all debris: roots, grass, rocks, etc.



Excavate the site. Contact your local utilities company to ensure there are no gas or electric lines buried in the area before digging.



Decide on the type of foundation you will be using: Concrete slab, or 4-6 inches of crushed gravel with paver stones or 4x4 stringers.

You can find the footprint for your shed on Page 3 of your Assembly Manual.



If doing the assembly yourself, have all the necessary tools ready to go and in working condition. A list of required tools can be found after the parts list.

Foundation Types for 6x4 Garden Shed

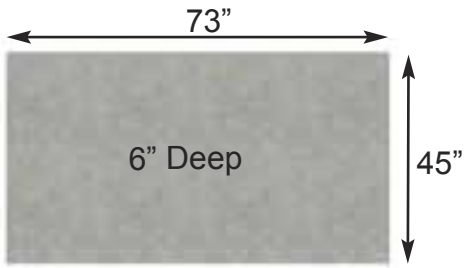

Concrete Foundation

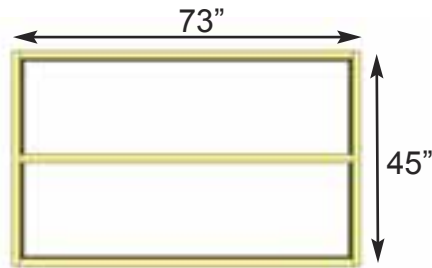

Floor Frame



Completed Foundation

Concrete Slab Foundation:

- Slab must be at least the same size as assembled floor frame (45" x 73") or larger.
- 6" Deep foundation.
- 0.5 Cubic Yards of concrete required.
- A concrete slab will have the longest durability out of your foundation options.

Once level, a concrete slab is the easiest surface to build on.

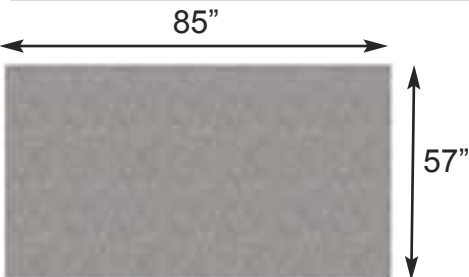

Gravel Foundation

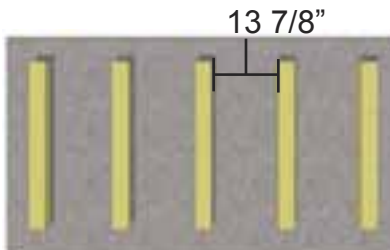

5 - 4"x4"x44 3/4"

Gravel Foundation with treated stringers

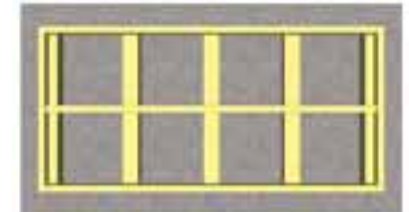

Completed Foundation

Gravel with 4x4 Pressure Treated Stringers:

- Excavate at least 6" deep, and 6" wider than floor frame on each side.
- 0.6 Cubic Yards of gravel required, approximately 6 wheelbarrows.
- 5 - 4x4 Pressure Treated Stringers 44 3/4" long required.
- Evenly spaced, with one at each end of floor frame.

Saves money on materials, easy to level and work with.

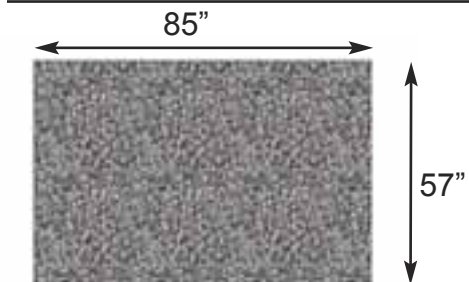

Gravel Foundation

12 Patio Stones

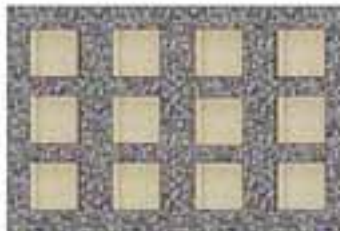

Gravel Foundation with Patio Pavers

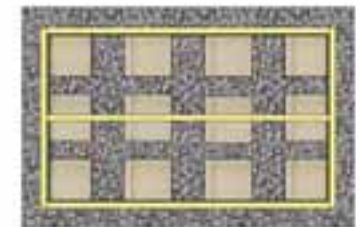

Completed Foundation

Gravel with Patio Paver Stones:

- Excavate at least 6" deep, and 6" wider than floor frame on each side.
- 0.6 Cubic Yards of gravel required, approximately 6 wheelbarrows.
- 12 patio pavers (8" x 8" or larger).
- Center patio paver stones underneath floor runners and underneath seams in floor joists.

Patio paver stones are widely available from most landscape stores.

**Thank you for purchasing our 6x4 Space Master.
Please take the time to identify all the parts prior to assembly.**

Parts List	Steps	D. - Trim / Misc. Section Cont.	Steps
<p>A. - Floor Section</p> <p>Floors 1 - Floor Section - 45" x 73" 1 - Mid Floor Joist - 1 1/2" x 2 1/2" x 70"</p>	A1	<p>Lower Skirting 2 - Lower Rear Skirting - 1/2" x 2 1/2" x 35 3/4" 4 - Lower Side Skirting - 1/2" x 2 1/2" x 21 3/4" Lower Front Skirting Short (2@1/2" x 2 1/2" x 11 3/4") Long (1@1/2" x 2 1/2" x 47")</p>	E1
<p>B. - Wall Section</p> <p>Main Wall Panels 2 - Rear Walls - 35" x 63 1/4" 4 - Side Walls - 22 1/2" x 63 1/4" 2 - Top Wall Plates - 1 1/2" x 1 1/2" x 35" 4 - Top Wall Plates - 1 1/2" x 1 1/2" x 22 1/2" 2 - Front Narrow Walls - 12 1/2" x 61 3/4"</p> <p>Header/Gables 1 - Front Header - 1 1/2" x 1 1/2" x 70" 1 - Interior Door Header - 1 1/2" x 1 1/2" x 44 7/8" 4 - Front/Rear Top Plate - Sides - 3/4" x 1 1/2" x 19" 2 - Front/Rear Top Plate - Center - 3/4" x 1 1/2" x 32" 2 - Side Wall Top Plates - 3/4" x 1 1/2" x 45" - Angle Cut 2 - Front/Rear Gables - 17 1/2" x 67 3/4"</p> <p>Shelves Storage Shelf Supports Short (2 - 3/4" x 2 1/2" x 12 1/2") Long (2 - 3/4" x 2 1/2" x 35") 2 - Storage Shelves - 11 1/2" x 41 7/8"</p>	B1 - B12 B13 - B23 B24 - B25	<p>Filler Trim 8 - Front/Rear Filler Trims - 5/8" x 1 1/2" x 30" 1 - Front Header Filler Strip - 5/8" x 1 1/2" x 69 1/2"</p> <p>Outer Wall Trim and Fascia 4 - Front/Rear Wide Corner Trims - 1/2" x 3 1/2" x 67 7/8" 6 - Side Wall Trims - 1/2" x 2 1/2" x 65 1/2" 1 - Rear Horizontal Trim - 1/2" x 3" x 67 1/4" 1 - Rear Center Trim - 1/2" x 2 1/2" x 64 3/4" 4 - Front/Rear Facia - 3/4" x 3 1/2" x 43" - Angle Cut Ends 2 - Side Fascia - 3/4" x 3 1/2" x 49" 2 - Pentagon Detail Plates - 1/2" x 5 1/2" x 8" 2 - Vertical Door Frame Trim - 1/2" x 2 1/2" x 64 1/4"</p>	E2 - E5 E6 - E16
<p>C. Rafters</p> <p>6 - Rafters - 1 1/2" x 2 1/2" x 41 3/4" 2 - Roof Ridge Boards - 3/4" x 3 1/2" x 45"</p>	C1 - C11	<p>Door System 1 - Door Threshold (Bevel) - 1/2" x 2 5/8" x 44 7/8" 2 - Left/Right Doors - 22 1/4" x 61 3/8" 1 - Door Flange - 1/2" x 2 1/2" x 61 3/8" 4 - Interior Vertical Door Stops - 3/4" x 3/4" x 29 7/8"</p> <p>Miscellaneous 1 - Front Horizontal Trim - 1/2" x 3" x 67 1/4" 1 - Metal Drip Edge - 60"</p> <p>** Plus 2 Cedar Shingle Shims - discard after shimming doors</p>	E17- E28
<p>D. Roof Section - CEDAR</p> <p>2 - Cedar Shingle Roof Panels - 45" x 53" 4 - Roof Nailing Strips - 3/4" x 1 1/4" x 40" 2 - Soffits - 1/2" x 2 1/2" x 45" 8 - Roof Ridge Caps - 12" 1 - Roof Ridge Caps - 10"</p>	D1-D6		E29
<p>D. Roof Section - METAL</p> <p>4 - Metal Roof Panels - 44" 2 - Soffits - 1/2" x 2 1/2" x 45" 6 - Battens - 3/4" x 3 1/2" x 49" 8 - Batten Spacers - 3/4" x 1 1/2" x 15 5/8" 1 - Metal Ridge Cap - 54" 8 - Foam Enclosures</p>	D1-D10	<p><u>Note:</u> We recommend you drill a 1/8" pilot hole for each screw to avoid splitting wood. The hole depth should be equal to 3/4 the length of screw.</p>	

Note: Trim and Skirting pieces are graded with the best face being rough sawn. Rough sawn cedar is much easier to paint and stain.

6x4 SPACE MASTER - DOUBLE DOORS

Hardware Kit (Provided)

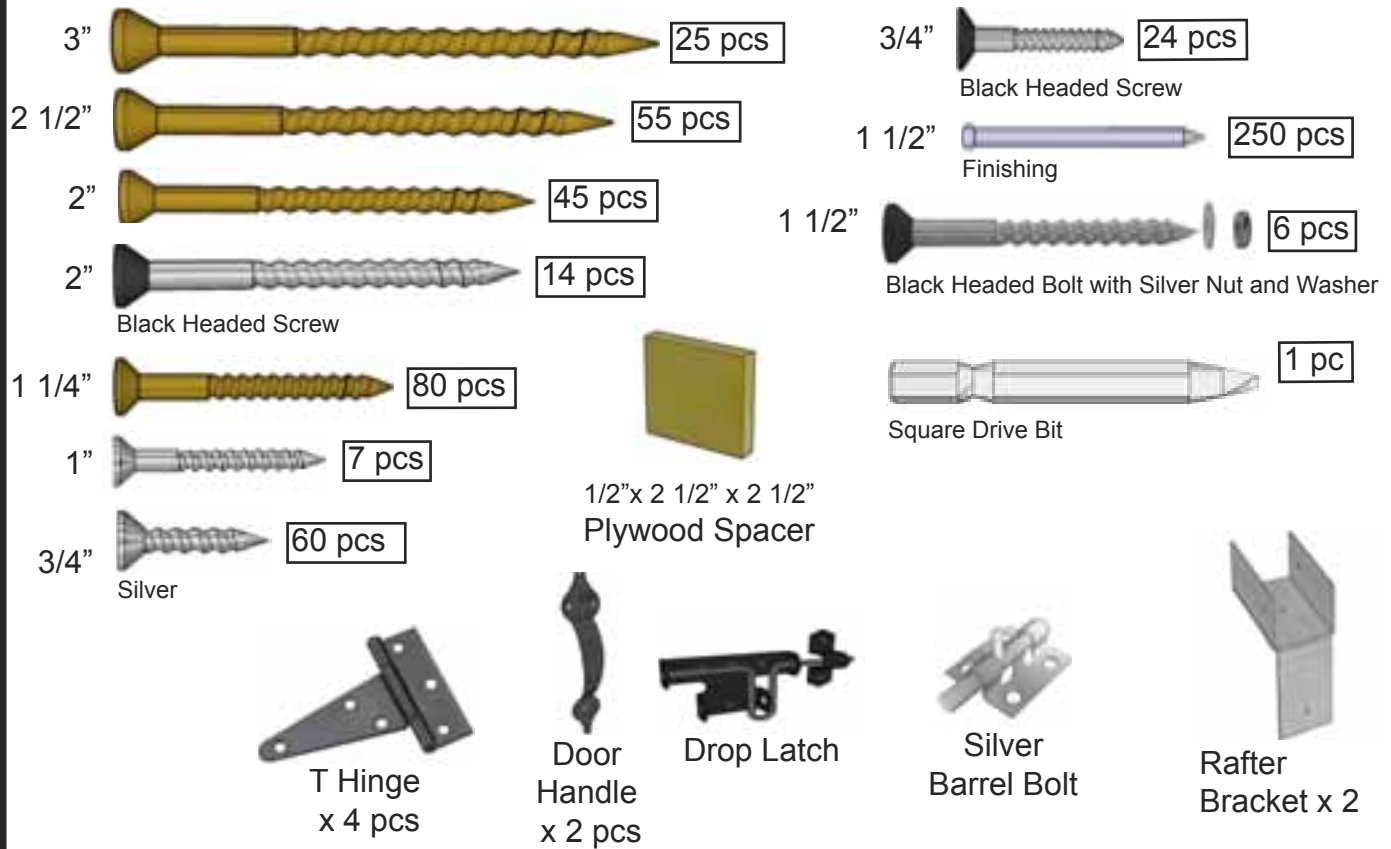

Hardware Kit - CEDAR ROOF (Provided)



Hardware Kit - METAL ROOF (Provided)



Tools Required (Not Provided)



Hammer



Screw Gun/Drill



Tape Measure



Wood Clamp



3/8" Wrench



Level



Pliers



Ladder



1/8" & 3/8" Drill Bits

Safety Equipment Required (Not Provided)



Safety Glasses



Work Gloves

Regular Maintenance & Tips to Prolong the Life of Your Shed.

Before/During Assembly:

- 1.) Paint each face and edge of your plywood floor with a latex exterior paint.
- 2.) Caulk wall seams if gaps appear.
- 3.) Caulk around window framing (if applicable).
- 4.) Caulk perimeter between floor plywood and bottom wall plate.
- 5.) Caulk channels in lap siding at the top of your door above the trim, just a drop in each channel.
- 6.) Caulk edge of door threshold (if applicable).
- 7.) Optional: Install a Sill Gasket between floor runners and foundation.
- 8.) Optional: Install an 8" strip of roofing paper below Cedar Ridge Caps for Cedar Roof Sheds.

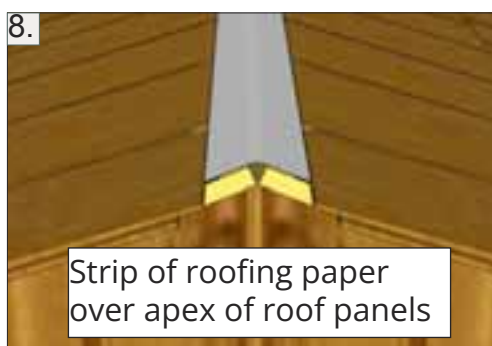
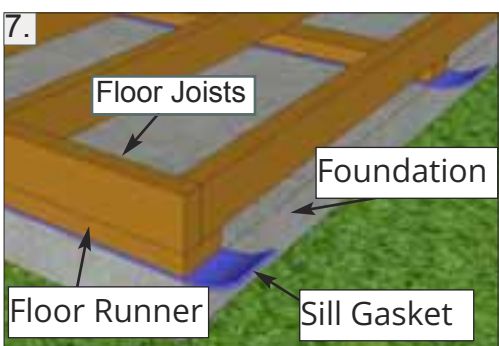
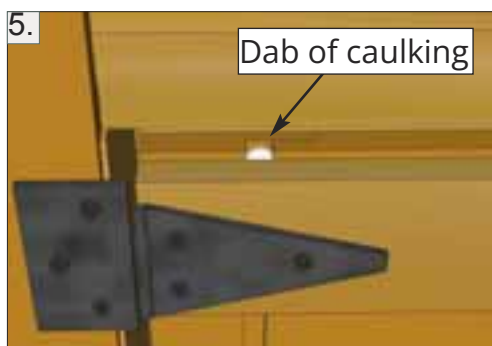
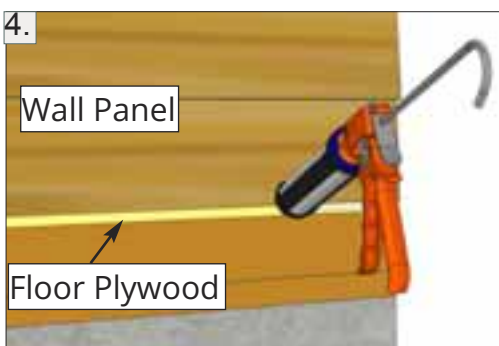
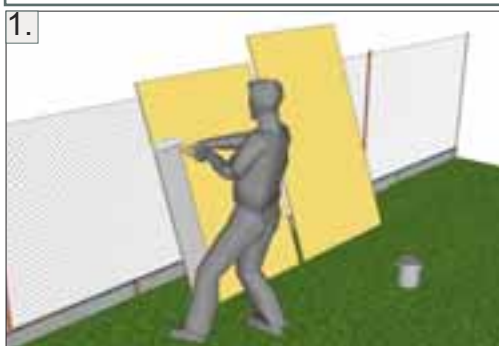

Routine Maintenance:

- Routinely check all fasteners are tight (ex. Door Hinges, Nails)
- Brush off dirt from walls.
- Brush off snow from roof regularly.
- Routinely remove needles and leaves from roof.

Painting/Staining

- Your cedar shed, if left untreated, will weather to a silvery grey colour.
- Painting or staining your structure is highly recommended and will prolong the life of your shed.
- You do not need to wait to paint or stain your shed, the wood in your kit has been dried and can be stained or painted immediately.
- Consult your local paint store for the best paint or stain for cedar.
- Optional: stain the inside of your shed. (Note: this will remove the fresh cedar smell.)

A. Floor Section

Exploded view of all parts necessary to complete the Wall Section. Identify all parts prior

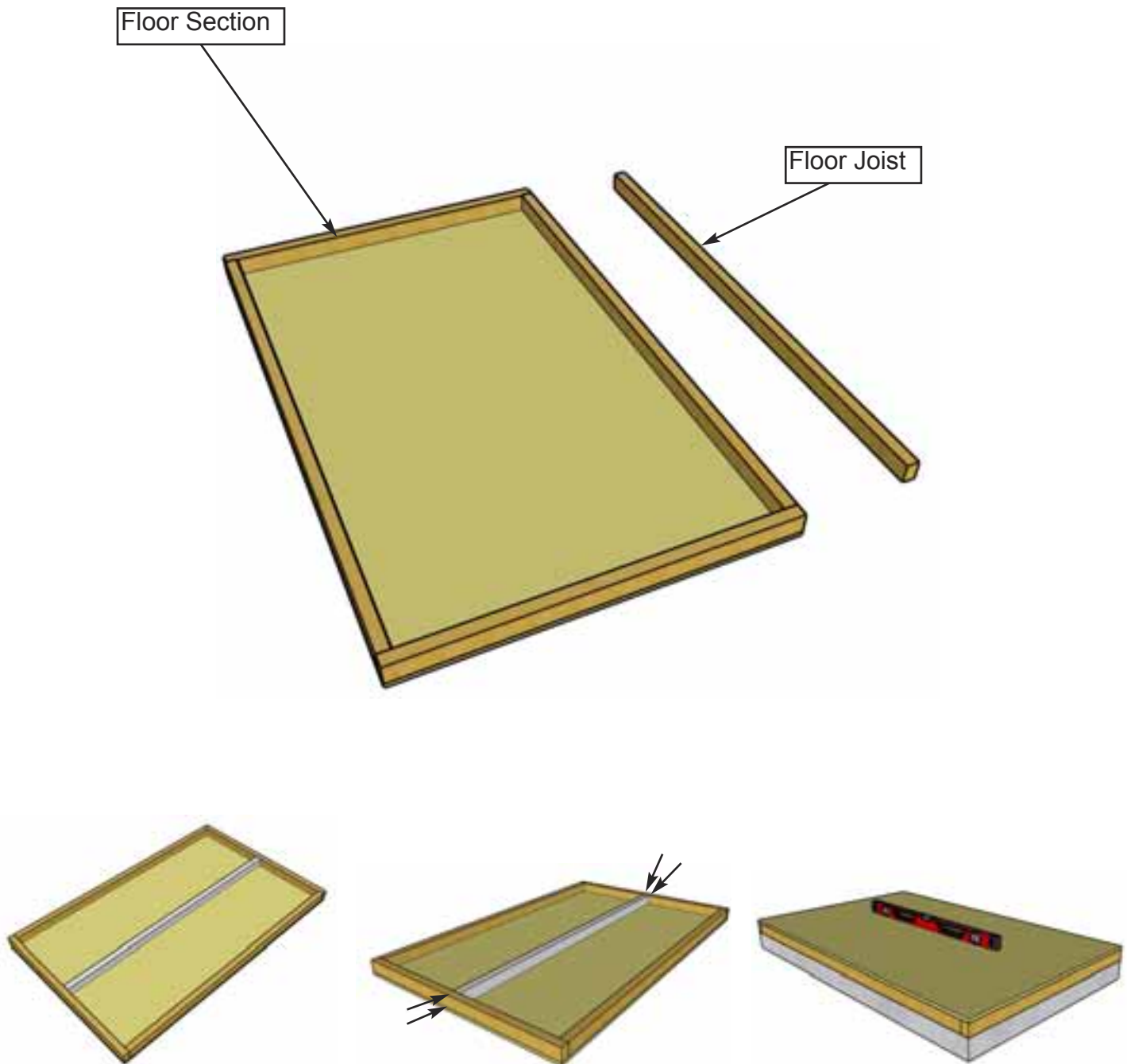

A1. Locate **Floor Joist** and position at center of **Floor Section** and flush with framing as illustrated above. Attach with 2 - 2 **1/2" Brown Screws** per end. Flip over and lay **Floor Section** on a level foundation only. Patio Stones or a Concrete Slab both make excellent foundations. (See Page 3 for more information on foundations). Use a level to confirm and shim **Floor Joist** as required.

Parts
Floor Joist
(1 1/2" x 2 1/2" x 70") x 1
Floor Section
(45" x 73") x 1

Hardware
2 1/2" Brown Screws
x 4 total

B. Wall Section

Exploded view of all parts necessary to complete the Wall Section. Identify all parts prior to starting.

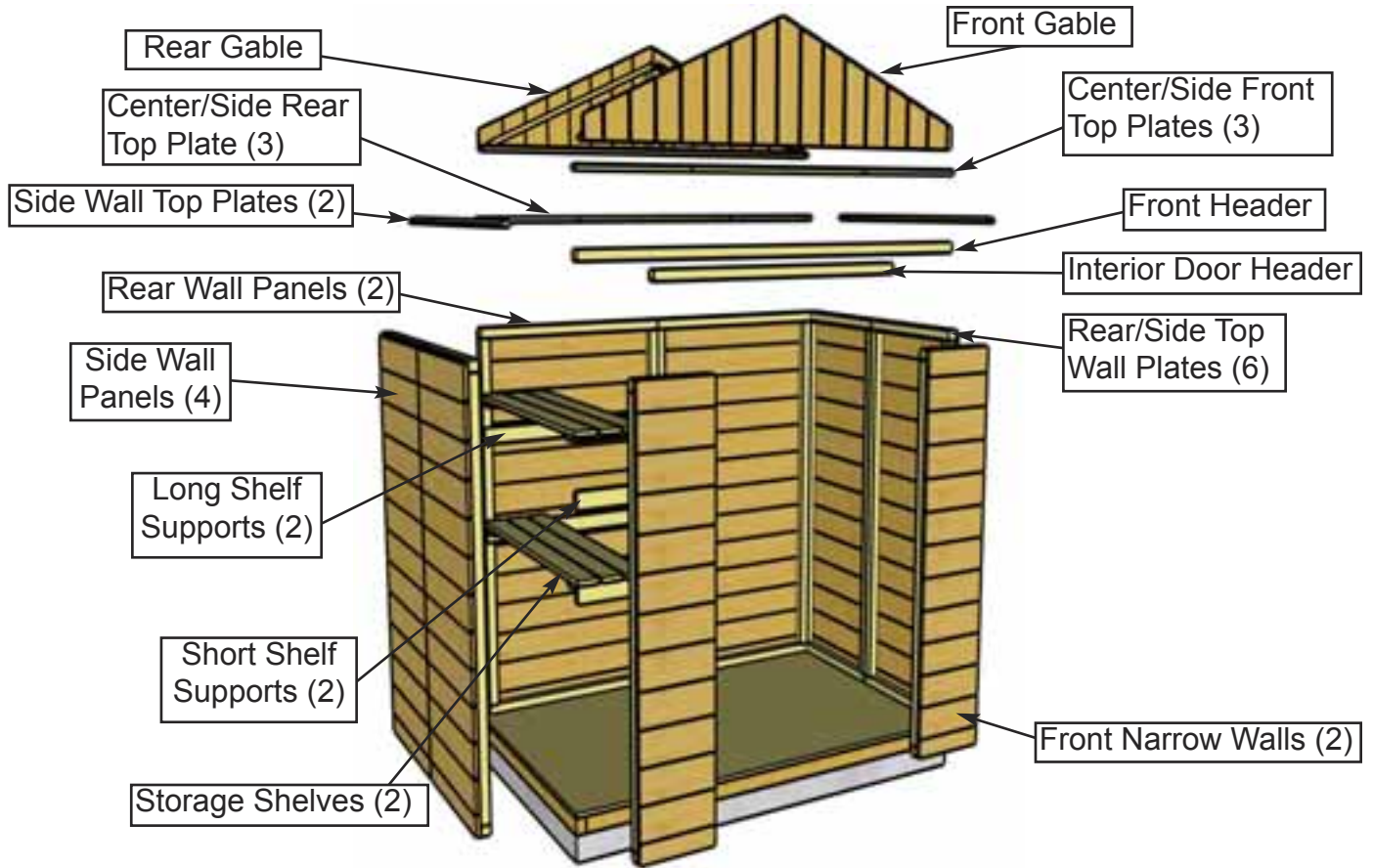

Due to packaging constraints, top wall plates must be attached prior to erecting walls.

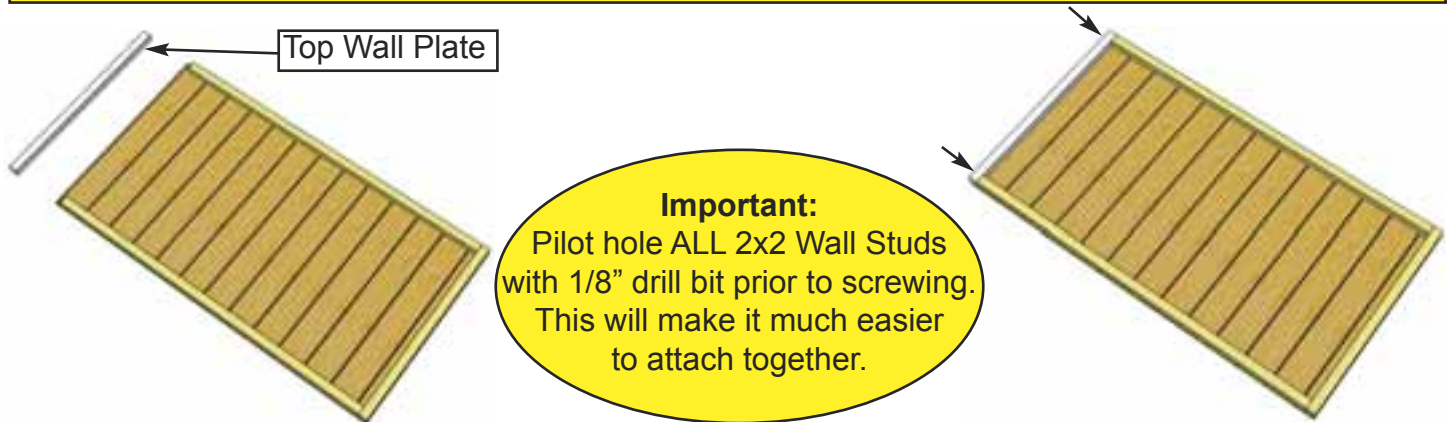

B1. For each Rear and Side Wall Panel, carefully lay Panel face down. Position and attach a Top Wall Plate to top of wall studs of each Wall Panel with 2 - 2 1/2" Brown Screws. Position so Plates are flush with framing.

Parts	Parts	Hardware
Rear Wall Panels (35" x 63 1/4") x 2	Side Wall Panels (22 1/2" x 63 1/4") x 4	2 1/2" Brown Screws x 12 total
Top Wall Plates (1 1/2" x 1 1/2" x 35") x 2	Top Wall Plates (1 1/2" x 1 1/2" x 22 1/2") x 4	

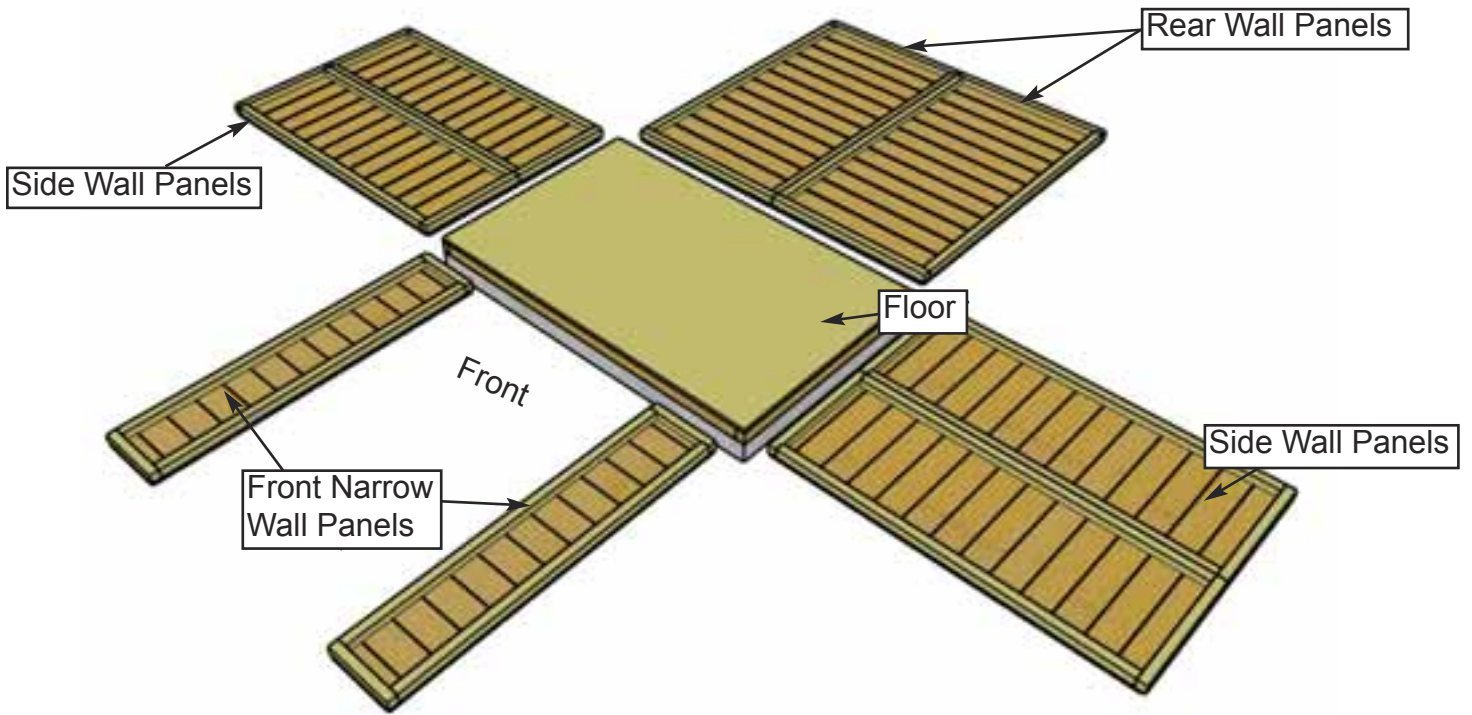

B2. With Wall Plates properly attached, orientate completed Walls around the Floor. Be sure to leave room to work. **Front Narrow Walls** will be required in this section.

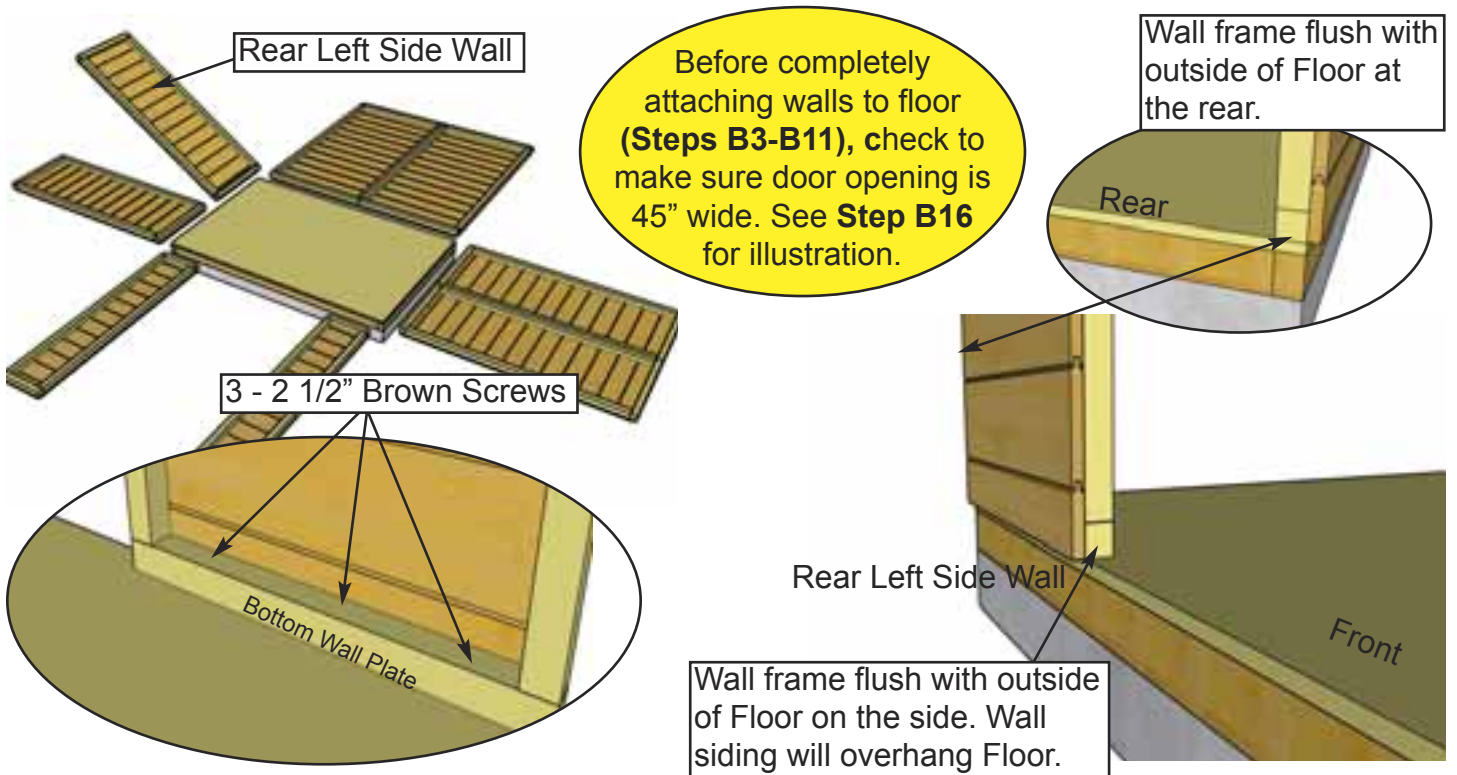

B3. Starting with **Rear Left Side Wall**, lift up and position so framing is flush with Floor at the rear of shed. Make sure Wall frame is flush with outside of Floor on the side. When Wall is positioned correctly, secure Bottom Wall Plate to Floor with **3 - 2 1/2" Brown Screws**.

Hardware (Steps 4 - 10)
2 1/2" Brown Screws
 x 20 total
3" Brown Screws
 x 15 total

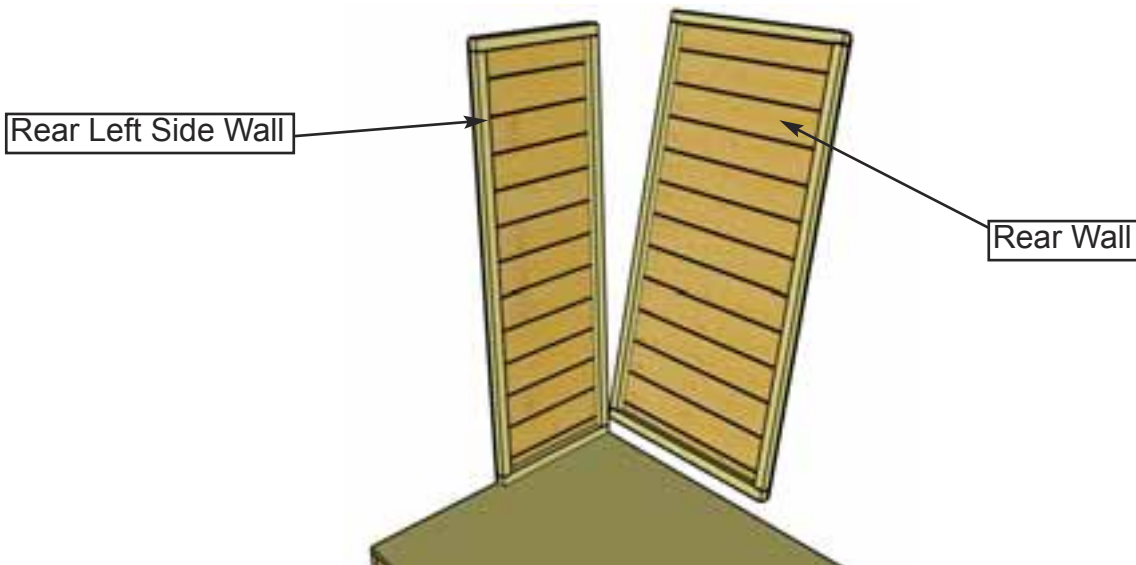

B4. With your helper holding the Side Wall Panel, position a **Rear Wall Panel** in rear corner. **Important: Align Wall Framing Flush with Floor Framing.**

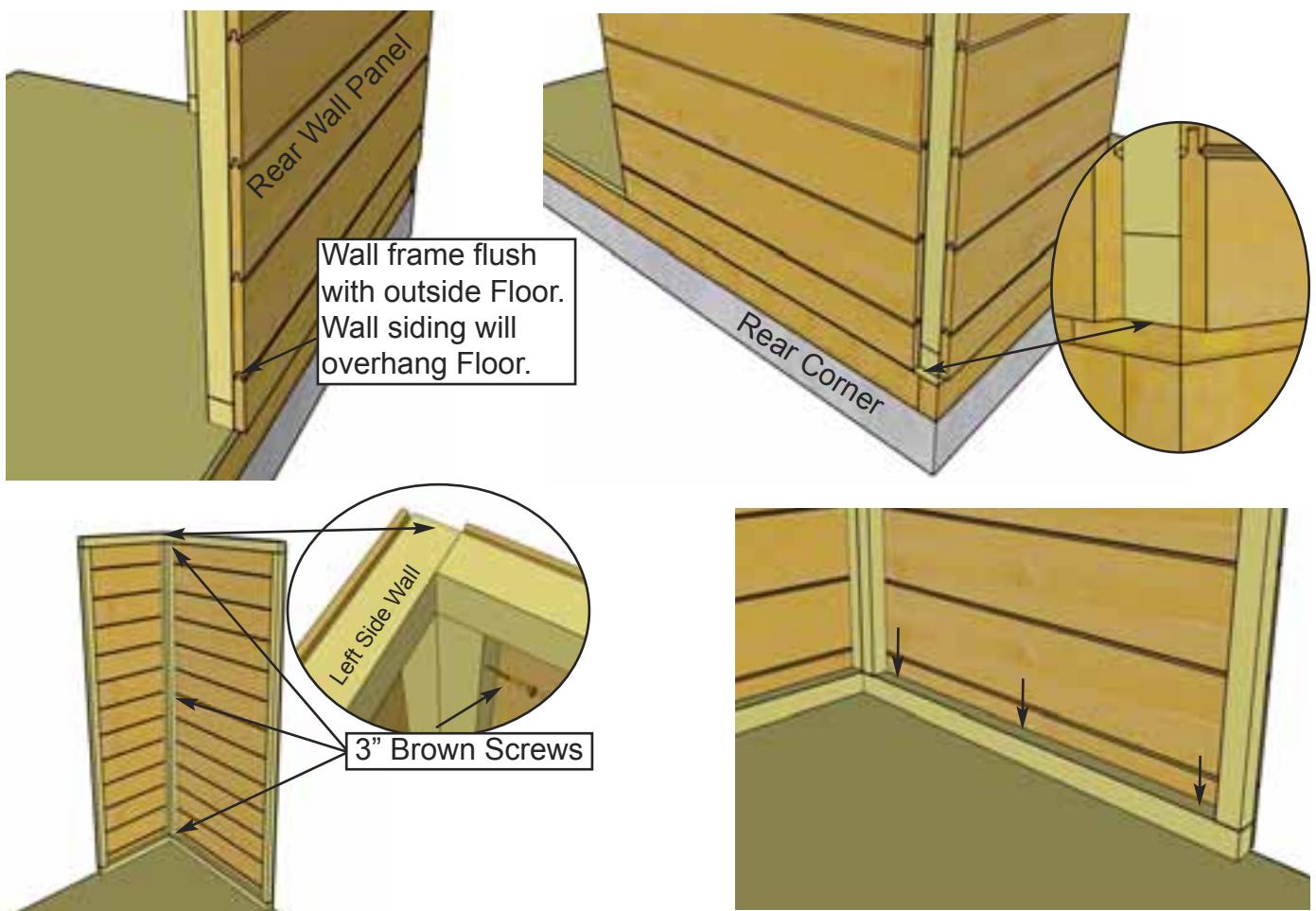

B5. When Side and Rear Walls are aligned in corner correctly, Wall framings will be flush. Attach Wall framings together with **3 - 3" Brown Screws**. Secure Bottom Wall Plate to Floor with **4 - 2 1/2" Brown Screws**.



B6. Position second Rear Wall Panel on Floor as per Step B5. Attach Wall frames together at top, middle and bottom with 3 - 3" Brown Screws. Secure Bottom Wall Plate to floor with 3 - 2 1/2" Brown Screws. Important: Confirm Siding on Rear Wall Panels are aligned.

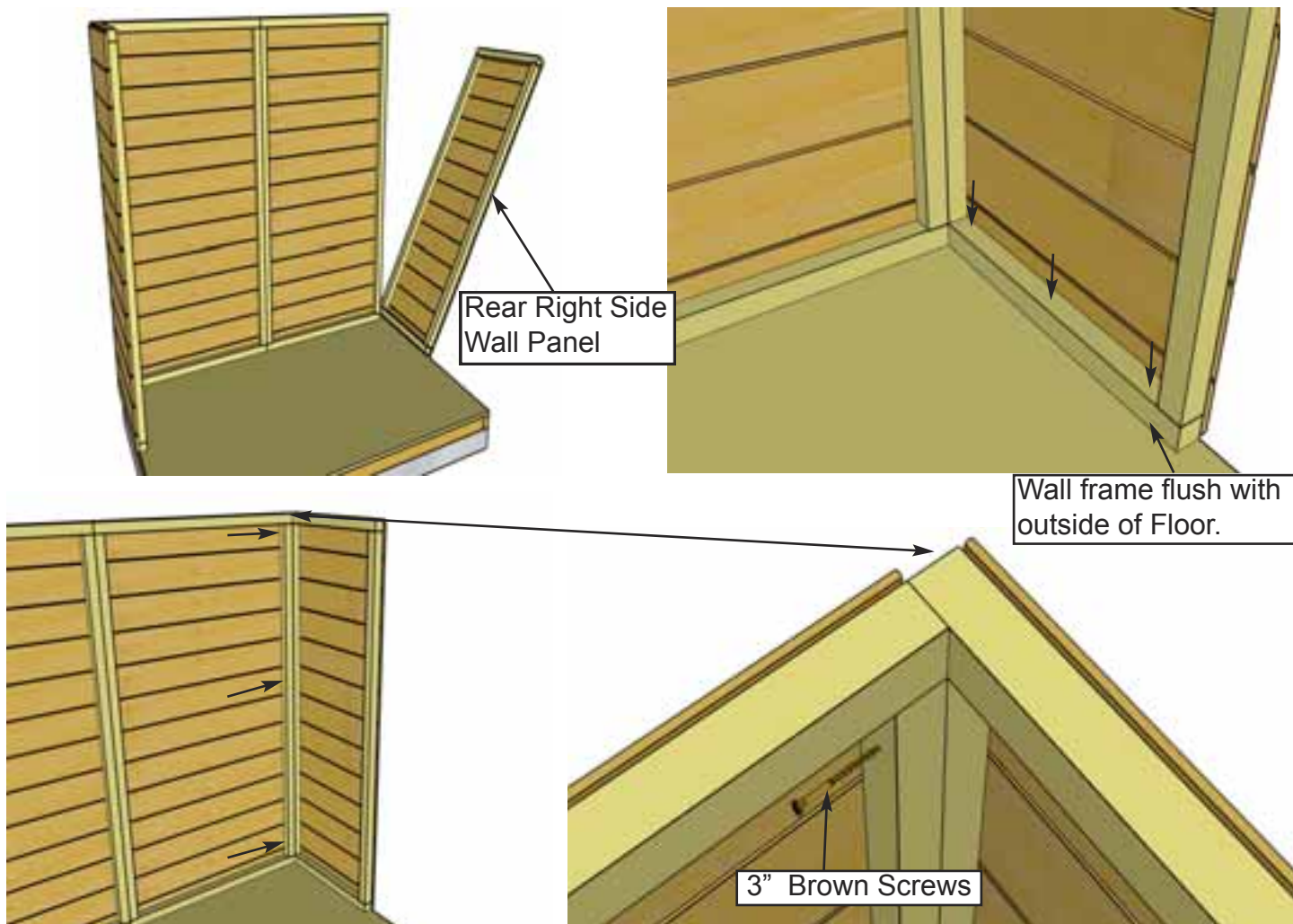

B7. In the corner, align and attach Right Side Wall framing to Rear Wall framing with 3 - 3" Brown Screws as per Step B5. Secure Bottom Wall Plate of Side Wall to Floor with 3 - 2 1/2" Brown Screws.



B8. Position second Left Side Wall Panel on Floor. Attach Wall frames together at top, middle and bottom with 3 - 3" Brown Screws. Secure Bottom Wall Plate to floor with 3 - 2 1/2" Brown Screws. Important: Confirm Siding on Side Wall Panels are aligned.

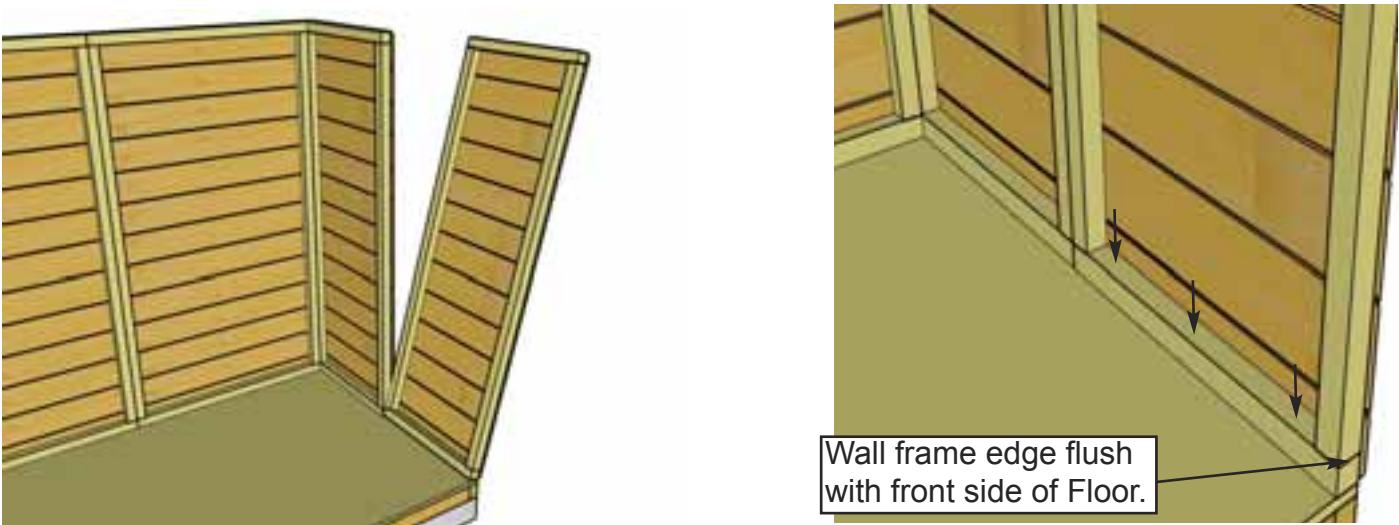

B9. Position second Right Side Wall on the floor. Attach walls frames together with 3 - 3" Brown Screws. Secure Bottom Wall Plate of Side Wall to Floor with 3 - 2 1/2" Brown Screws.

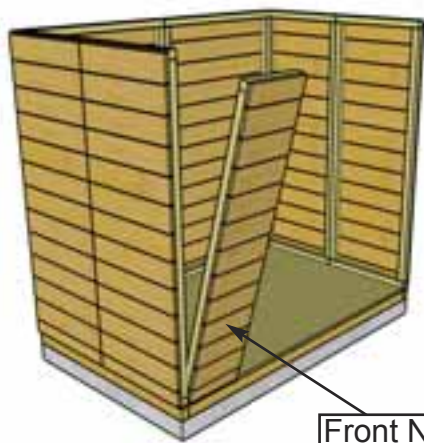

Front Narrow Wall



Wall Framings Flush

Side Wall

B10. Locate Front Narrow Walls and position Wall framing flush with Side Wall framing in corner. **Important: Make sure Narrow Wall is positioned right side up.**

Parts (Steps B10 - B12)
Front Narrow Wall Panels
 (12 1/2" x 61 3/4") x 2

Hardware (Steps B10 - B12)
2 1/2" Brown Screws
 x 4 total
3" Screws
 x 6 total

Wall frame flush with Floor. Siding will overhang Floor.

Before attaching, make sure door opening is 45" wide.

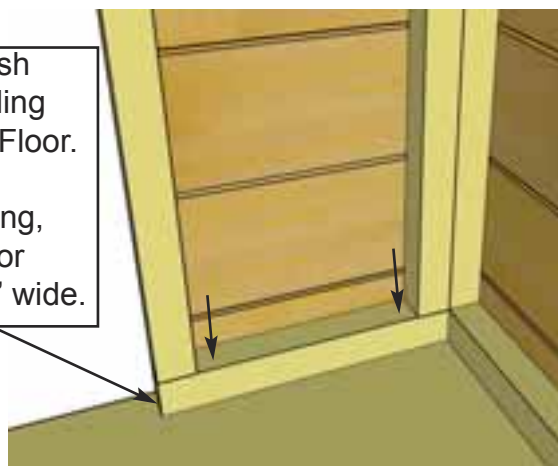

B11. Align Wall framing flush with outside of Floor framing. When correctly positioned, secure Bottom Wall Plate to Floor with 2 - 2 1/2" Brown Screws. Attach vertical Wall framings together at top, middle and bottom with 3 - 3" Brown Screws.



B12. Align and attach the second Front Narrow Wall Panel as per Step B11.

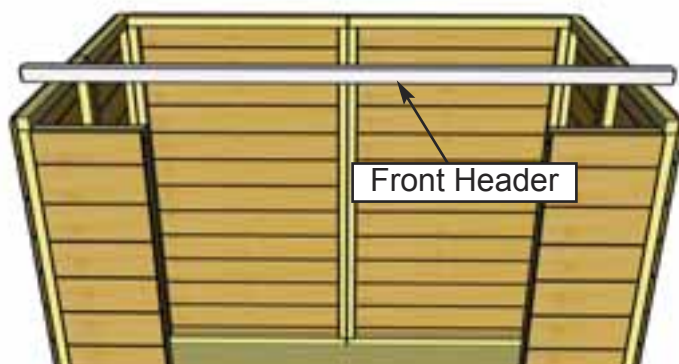

Front Header

B13. Locate Front Header and place on top of Front Narrow Wall framings.

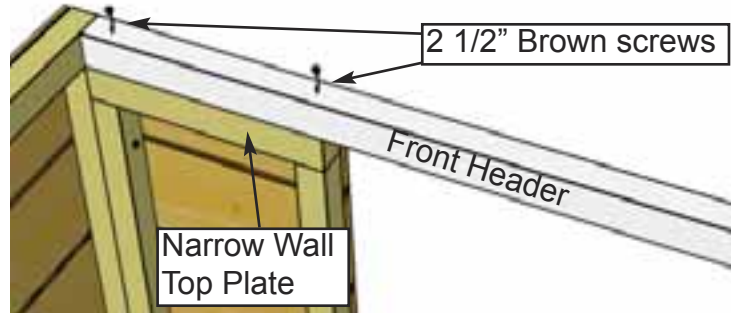
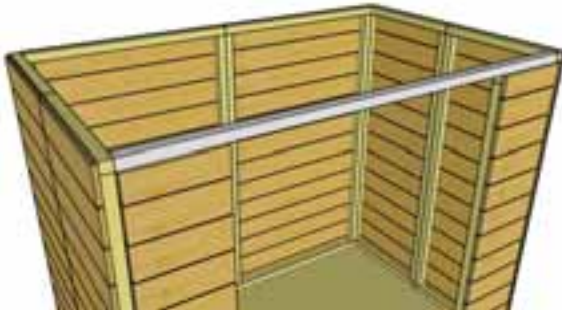

B14. With Front Header positioned evenly on Narrow Wall top plates and flush against Side Wall top framing, secure using 4 - 2 1/2" Brown Screws screwing down from the top of Front Header down into the upper Narrow Wall plates. Have your helper push side walls against the end of Front Header to achieve tight.

Parts
Front Header
 (1 1/2" x 1 1/2" x 70")

Hardware
2 1/2" Brown Screws
 x 4 total

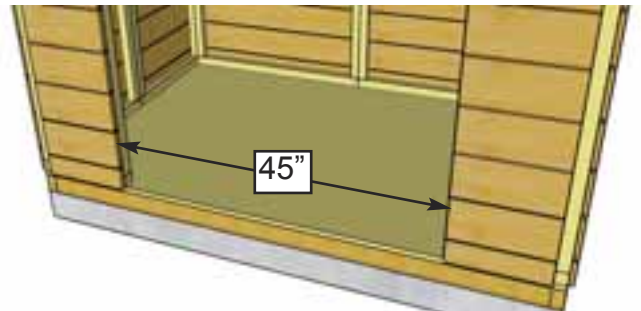
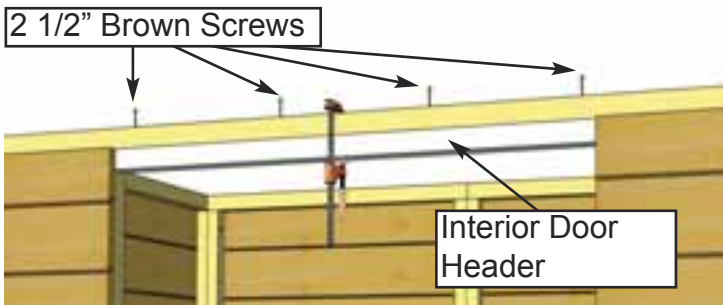

B15. Position Interior Door Header underneath and flush with Front Header. Attach with 4 - 2 1/2" Brown Screws. Screw down from the Front Header into Interior Door Header. Use Clamp to hold Interior Door Header.

Parts
Interior Door Header
 (1 1/2" x 1 1/2" x 44 7/8")

Hardware
2 1/2" Brown Screws
 x 4 total

B16. When all Walls are attached together, check door width at top and bottom. Door width should be 45" wide. If required, loosen Narrow and Side Wall plate screws, adjust door width and re-secure. There can be an 1/8" tolerance in the width but top and bottom width should be the same.

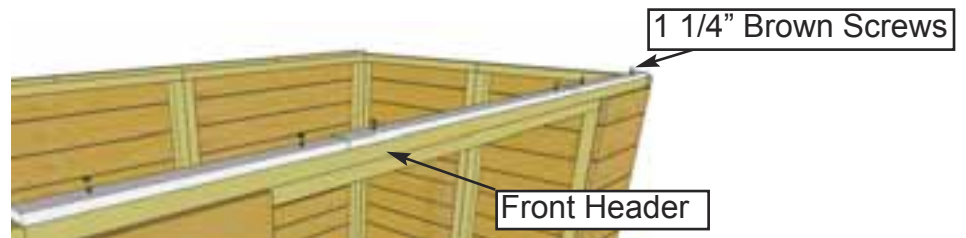
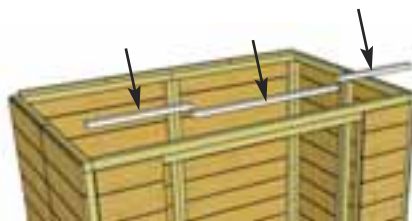

B17. Locate Side and Center Top Plates and place on top of the Front Header. With Front Top Plates positioned evenly and flush against Front Header, secure using 6 - 1 1/4" Brown Screws screwing down from the top of Top Plates down into Front Header.

Parts
Front Top Plate - Sides
 (3/4" x 1 1/2" x 19") x 2
Front Top Plate - Center
 (3/4" x 1 1/2" x 32")

Hardware
1 1/4" Brown Screws
 x 6 total

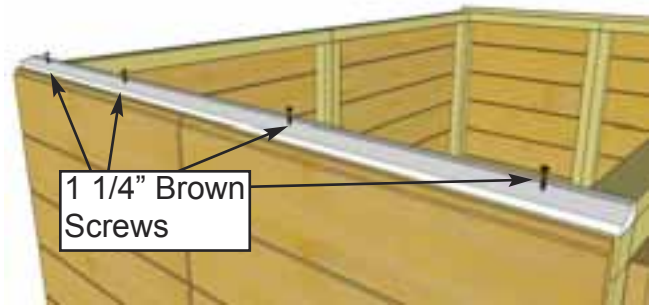
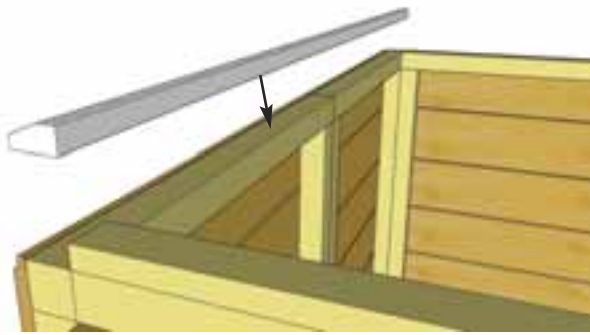

B20. Locate and position first **Side Wall Top Plate** on Side Wall frame so they are flush. Side Wall Top Plates are angle cut down the length. Attach Side Wall Top Plate to Side Wall framing with **4 - 1 1/4" Brown Screws**.

<u>Parts</u> Side Wall Top Plate (Angle) (3/4" x 1 1/2" x 45")	<u>Hardware</u> 1 1/4" Brown Screws x 4 total
---	--

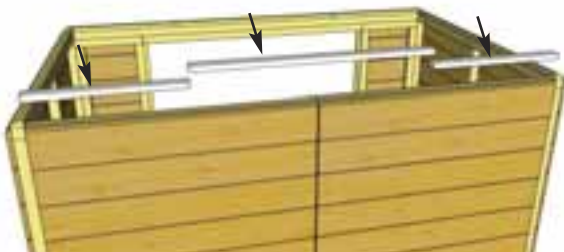

B21. Locate **Side and Center Top Plates** and place on top of Rear Walls. With Top Plate positioned evenly and flush against Rear Wall framing, secure using **6 - 1 1/4" Brown Screws** screwing down from the top of Rear Top Plate down into the Rear Wall top plates.

<u>Parts</u> Rear Top Plate - Sides (3/4" x 1 1/2" x 19") x 2 Rear Top Plate - Center (3/4" x 1 1/2" x 32")	<u>Hardware</u> 1 1/4" Brown Screws x 6 total
---	--

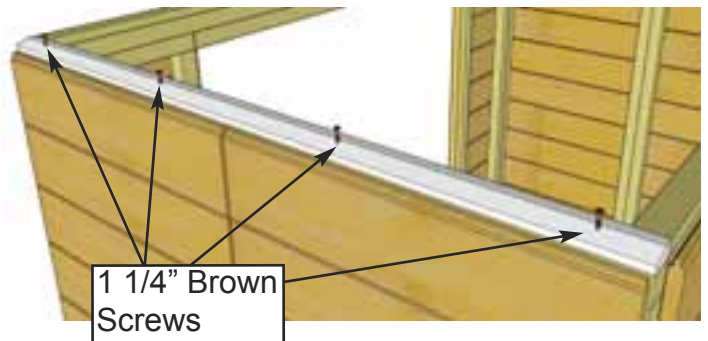
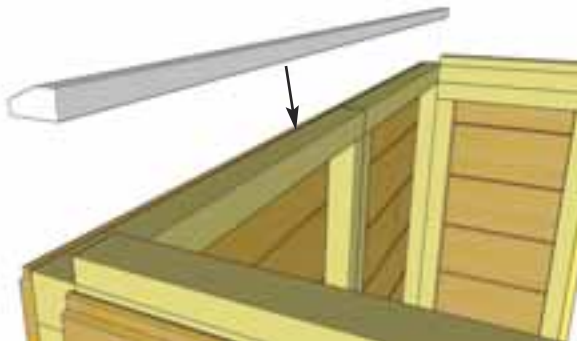

B22. Complete opposite **Side Wall Top Plate** positioning and attachment as per Step B20.

<u>Parts</u> Side Wall Top Plate (Angle) (3/4" x 1 1/2" x 45")	<u>Hardware</u> 1 1/4" Brown Screws x 4 total
---	--

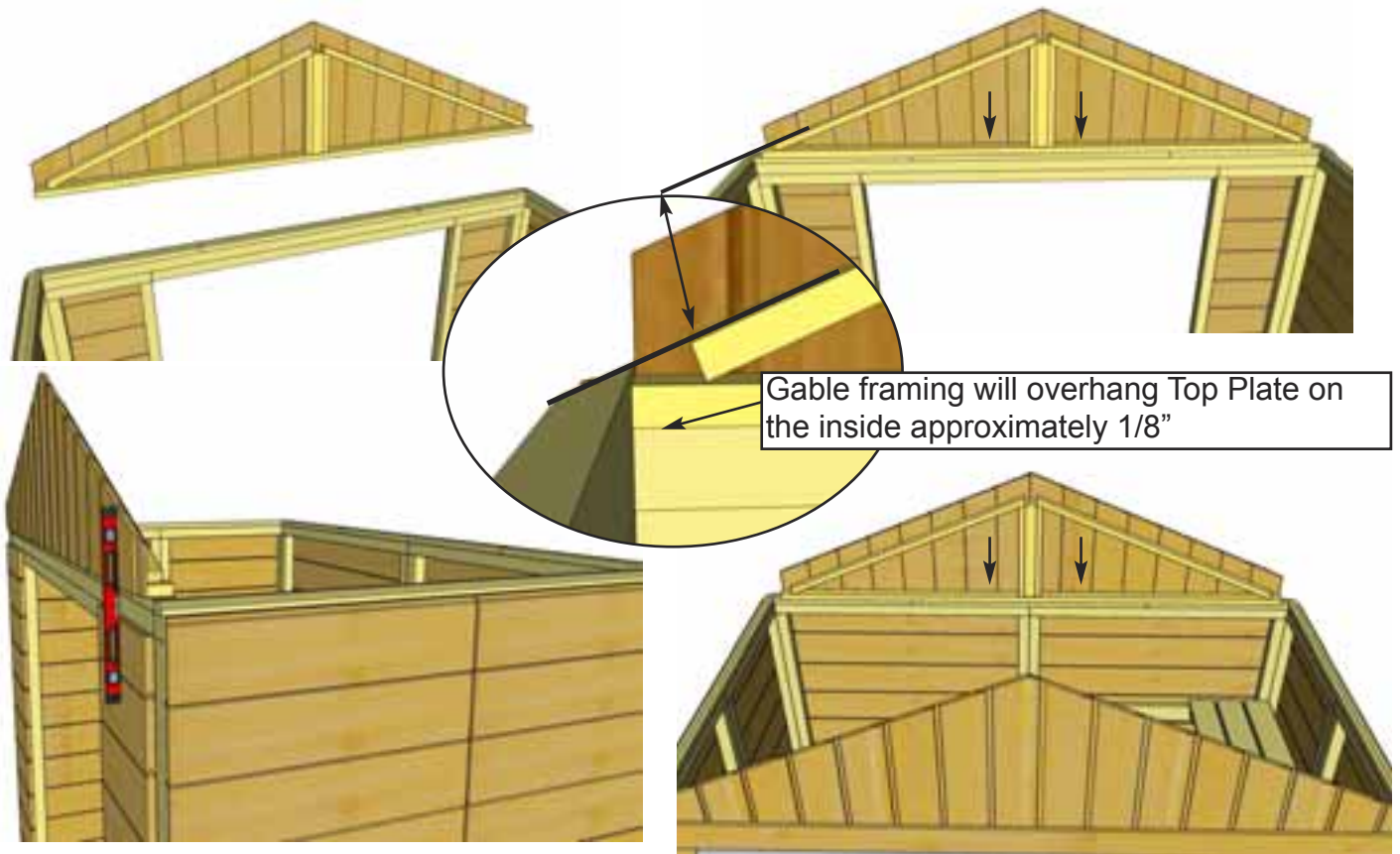

B23. Locate **Front/Rear Gables** and position so Gable siding sits flush with Wall siding on the outside. Gable will fit evenly between Side Wall Top Plates. Temporarily attach Rear Gable to Rear Top Wall Plate with 2 - **2" Brown Screws**. Gables may need slight adjustment in **Step C9** when attachment will be completed with an additional 4 Screws. Screw from the bottom of Gable framing down into Rear Top Wall Plate and Wall Framing. Complete Gable positioning and attachment on the other side. Note: Gable Framing may overhang Top Plate on the inside by approximately 1/8".

<u>Parts</u> Front/Rear Gables (17 1/2" x 67 3/4") x 2	<u>Hardware</u> 2" Brown Screws x 4 total
---	---

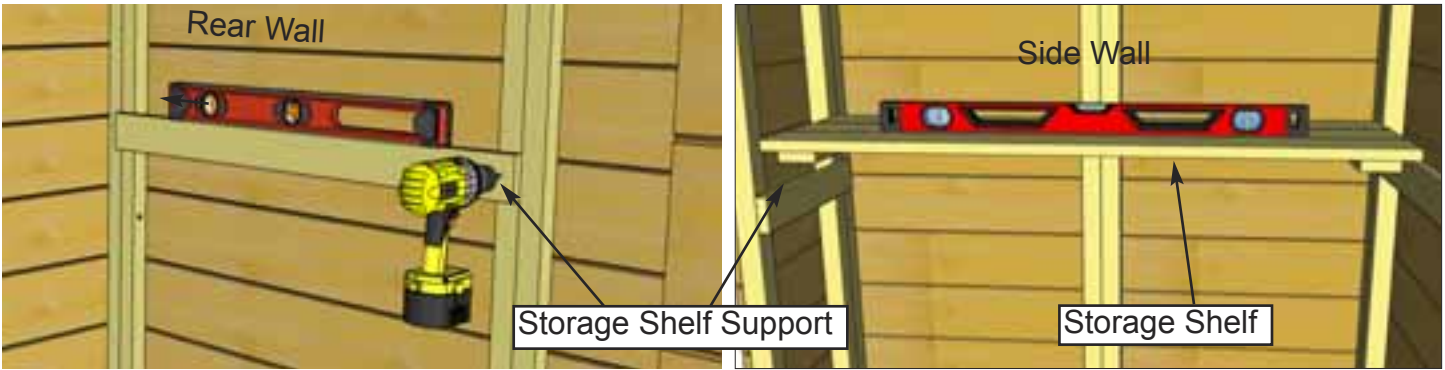

B24. Storage Shelf positioning is flexible so decide what height configuration suits your needs. Gather your **Storage Shelf Supports**. The short Support (12 1/2") attaches to the Narrow Wall, the long (35") to the Rear Wall. Position using a Level, and drill Pilot Holes to prevent ends of Supports from splitting. Attach first Support using 2 - 1 1/4" **Brown Screws**. Place **Storage Shelf** on attached Support, Level, and mark position of second Support. Pilot Hole and secure second Support.

<p><u>Parts (Steps B24 - B25)</u> Short Storage Shelf Supports (3/4" x 2 1/2" x 12 1/2") x 2 Long Storage Shelf Supports (3/4" x 2 1/2" x 35") x 2 Storage Shelves (11 1/2" x 41 7/8") x 2</p>	<p><u>Hardware Parts (Steps B24 - B25)</u> 1 1/4" Brown Screws x 8 total 1 1/2" Finishing Nails x 8 total</p>
---	---



B25. Place **Storage Shelf** on top of supports and secure with 4 - 1 1/2" **Finishing Nails**. Complete 2nd Shelf (if desired) as per **Steps B24 & B25**.

C. Rafter Section

Exploded view of all parts necessary to complete the Rafter and Roof Section. Identify all

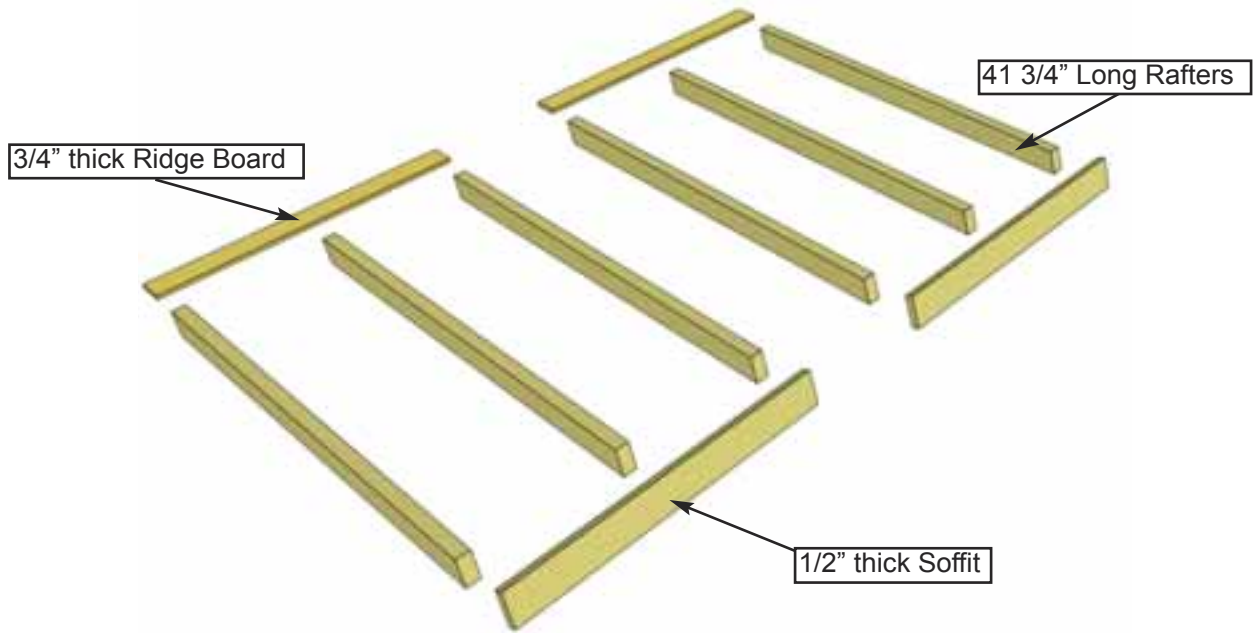

C1. Locate 6 Rafters, 2 Ridge Boards, and 2 Soffits. Evenly space out Rafters and lay out as illustrated, on a flat level surface.

Important:
Pilot Hole Ridge Board and Soffit prior to screwing to prevent splitting!

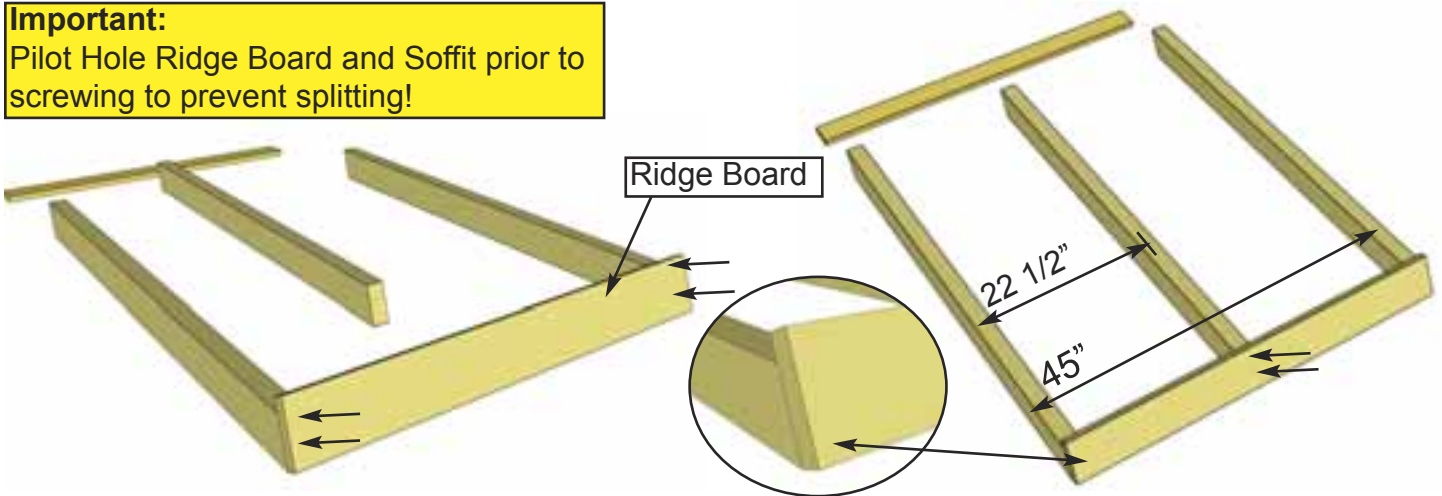

C2. Starting with first Rafter section, attach Ridge Board to ends of both outside rafters with 2 - 2" Brown Screws per end. Drill 1/8" pilot holes in Ridge Board to prevent splitting. Measure and position interior Rafter as illustrated. When positioned correctly, attach Ridge Board to remaining Rafter with 2 - 2" Brown Screws.

Parts (Steps C2 - C4)	Hardware (Steps C2 - C4)
Rafters x 6 (1 1/2" x 2 1/2" x 41 3/4")	2" Brown Screws x 12 total
Ridge Boards x 2 (3/4" x 3 1/2" x 45")	1 1/4" Brown Screws x 12 total
Soffits x 2 (1/2" x 2 1/2" x 45")	

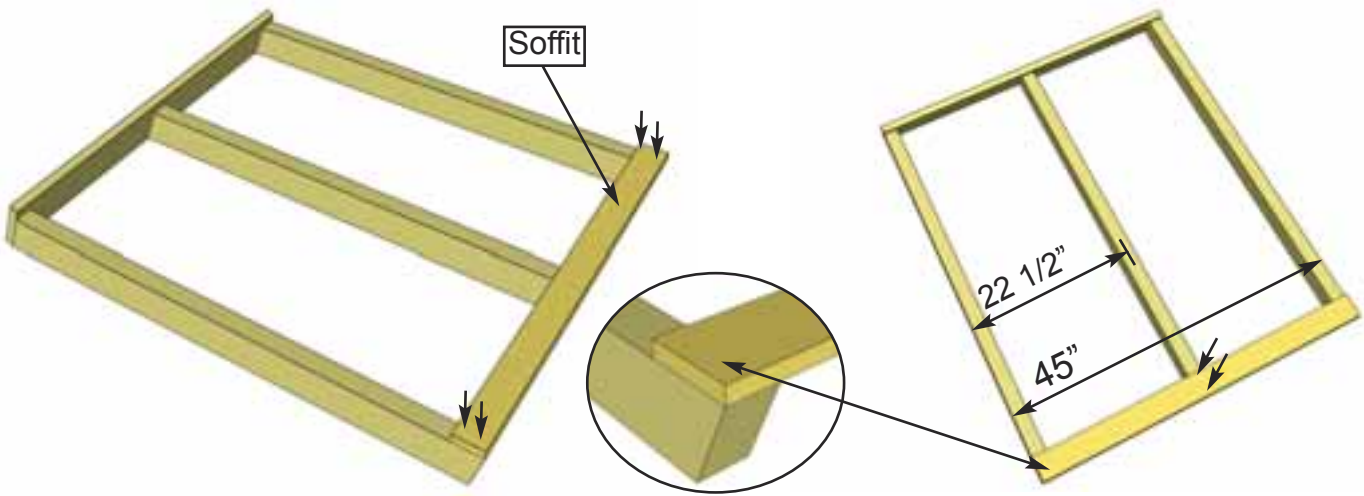

C3. Attach end of Soffit Board flush to ends of outside Rafters with 2 - 1 1/4" Brown Screws per rafter end. Drill 1/8" pilot holes in Soffit ends to prevent splitting. Measure and position interior Rafter as illustrated. When positioned correctly, attach Soffit to remaining Rafter with 2 - 1 1/4" Brown Screws.

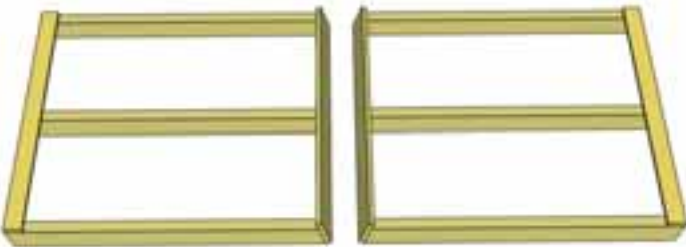

C4. Complete second Rafter section now as per Steps C2 - C5.

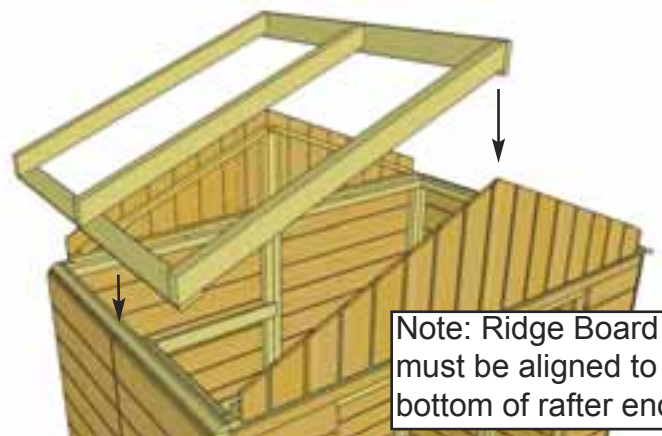
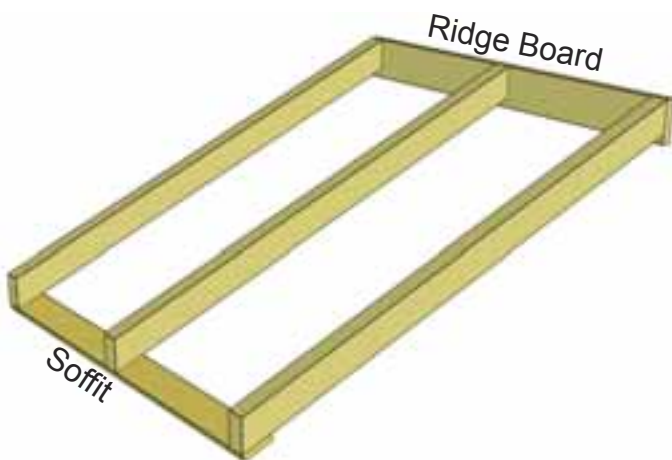

Note: Ridge Board must be aligned to bottom of rafter end

C5. Flip Rafter section over so Soffit is facing down. Starting with one side, lift completed Rafter Section up and place on Gable framing.

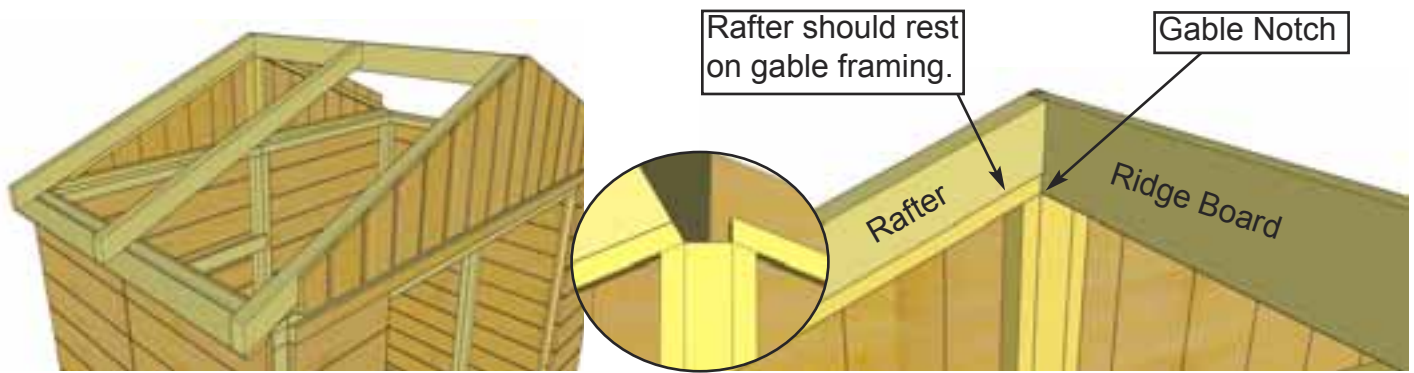

C6. Slide Rafter section up on Gable framing until bottom of Ridge Board slips into Gable notch.

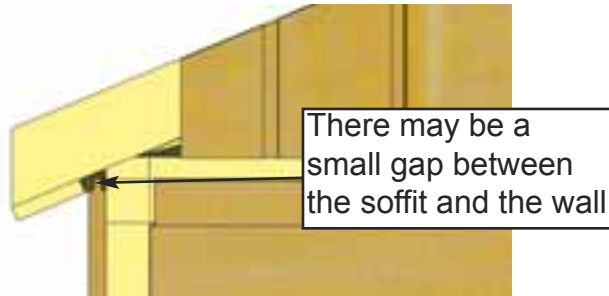

C7. When Rafter section is correctly positioned, outside rafters will sit equally on Gable framing and soffit will sit approximately 1/4" away from wall panels.

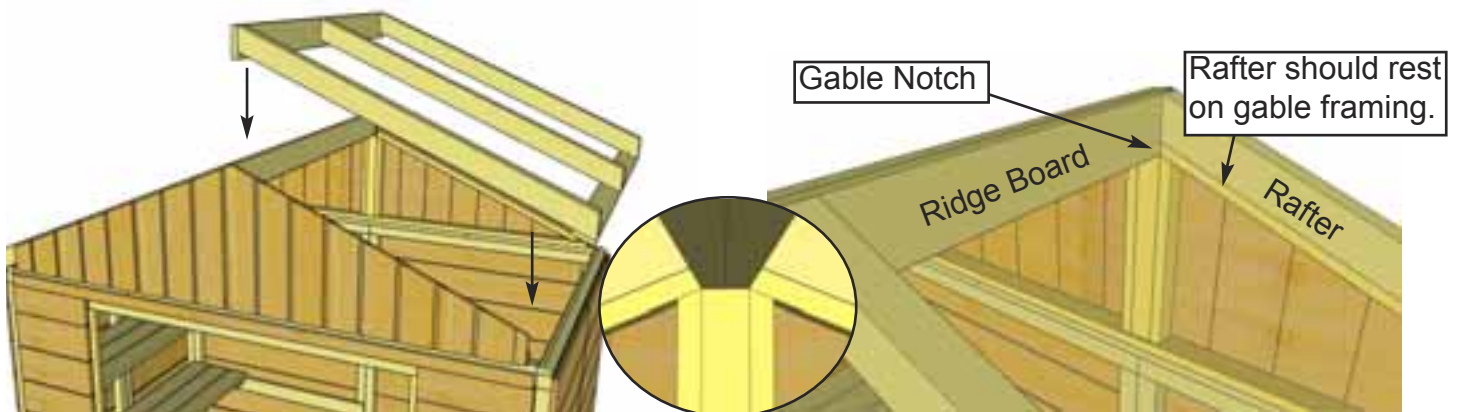

C8. Place second completed Rafter section on Gable framing as per Steps C5 - C7.

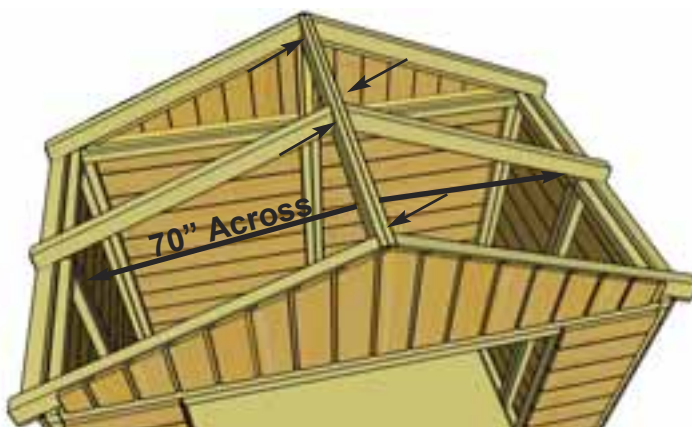

C9. At the peak, align Ridge Boards so they are flush together and secure them with 4 - 1 1/4" Brown Screws. **Important:** If there is a gap between Ridge Boards, have a helper push the Side Walls closer together from outside. Walls should be 70" apart at top from inside of Wall plate to opposite Wall plate.

Hardware
 1 1/4" Screws
 x 4 total



C10. With both Ridge Boards connected, completely secure Gable framing to Walls and Rafters. Use 3 - 2" Brown Screws per Rafter. Use an additional 4 - 2" Brown Screws to secure Gable to Wall. Note: you may have to remove the 2 temporary screws in Gable from Step B23 and reposition Gable for best fit prior to completing Gable attachment.

Hardware
2" Brown Screws x 20 total



C11. Attach middle Rafter to Side Wall Top Plate inside of shed using a rafter bracket and 4 - 1/4" Brown Screws. Complete attachment of opposite middle Rafter.

Hardware
Rafter Bracket x 2 total
1 1/4" Brown Screws x 8 total

D. Roof Section - Cedar

Exploded view of all parts necessary to complete the Roof Section. Identify all parts prior to starting.

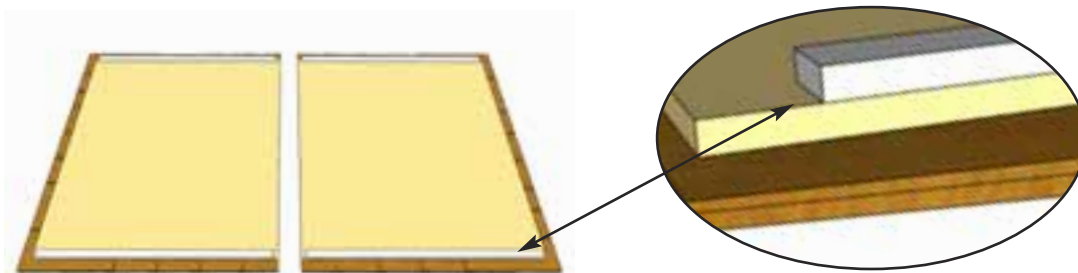
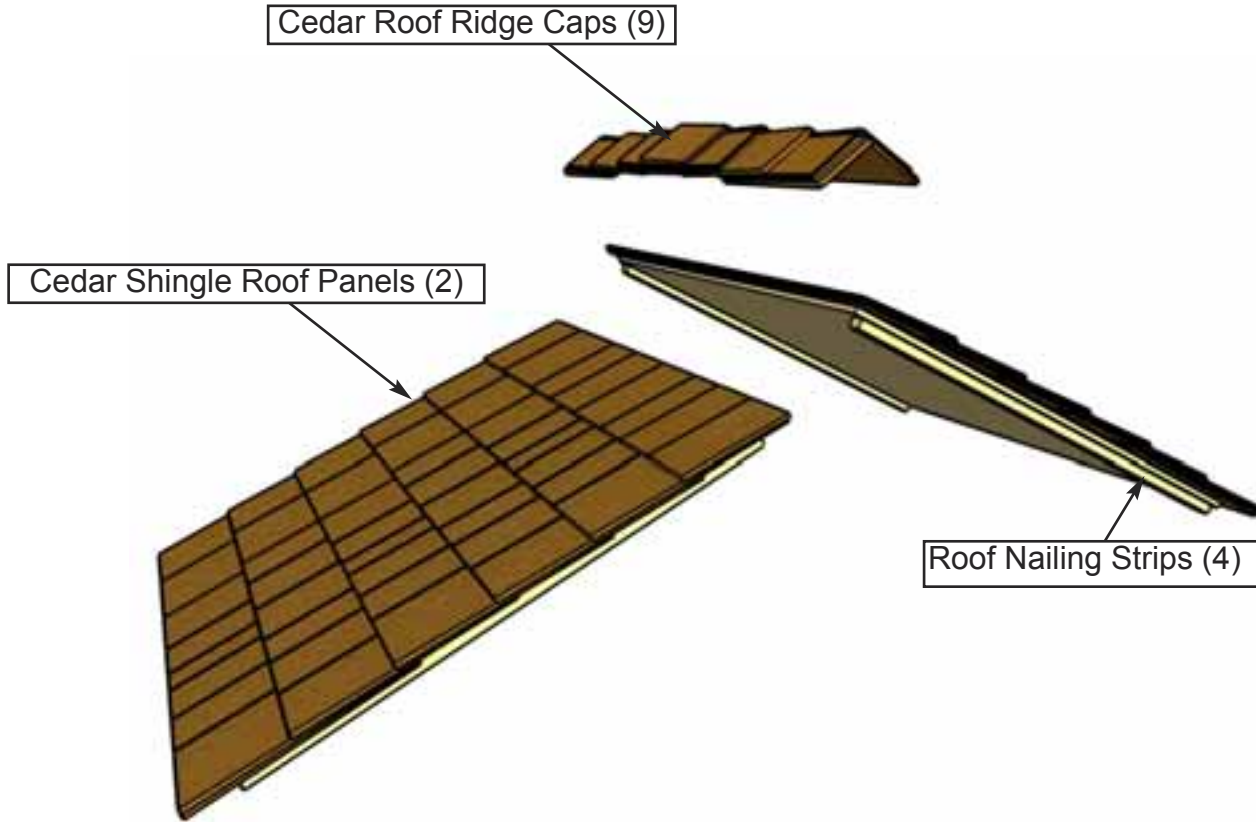

D1. Carefully flip Cedar Shingle Roof Panels over so plywood is facing up. Attach Roof Nailing Strips onto outside of each panel flush with plywood. Attach with 3 - 1 1/4" Screws evenly spaced. Nailing Strips provide for a greater nailing surface later when you attach Front/Rear Fascia Trim.

Parts	Hardware
Roof Nailing Strips (3/4" x 1 1/4" x 40") x 4	1 1/4" Screws x 12 total



D2. Lift up first Cedar Shingle Roof Panel and place on Rafters. At the front and rear, plywood roofing should overhang Rafters by 2" and recessed 1/8" back from Rafters at the side.

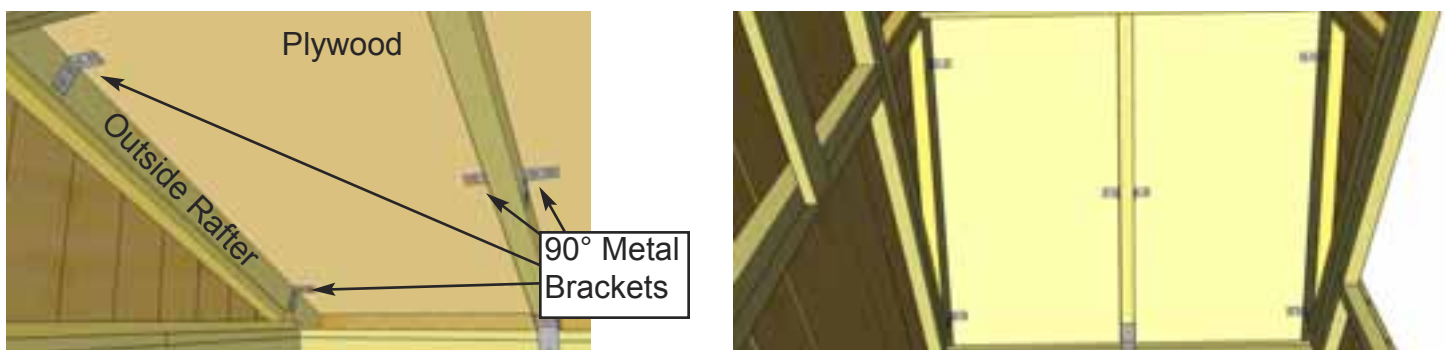

D3. Inside the shed, position 6 - 90° Metal Brackets onto the Roof plywood and Rafters and secure with 4 - 3/4" Silver Screws each Bracket. For each Roof Panel, 4 - 90° Metal Brackets will be used for the outside Rafters and 2 - 90° Metal Brackets will be used to secure the middle Rafter.

<p><u>Parts (Steps D3 - D4)</u> Cedar Shingle Roof Panel (45" x 53") x 2</p>	<p><u>Hardware (Steps D3 - D4)</u> 90° Metal Brackets x 12 total 3/4" Silver Screws x 48 total</p>
---	--

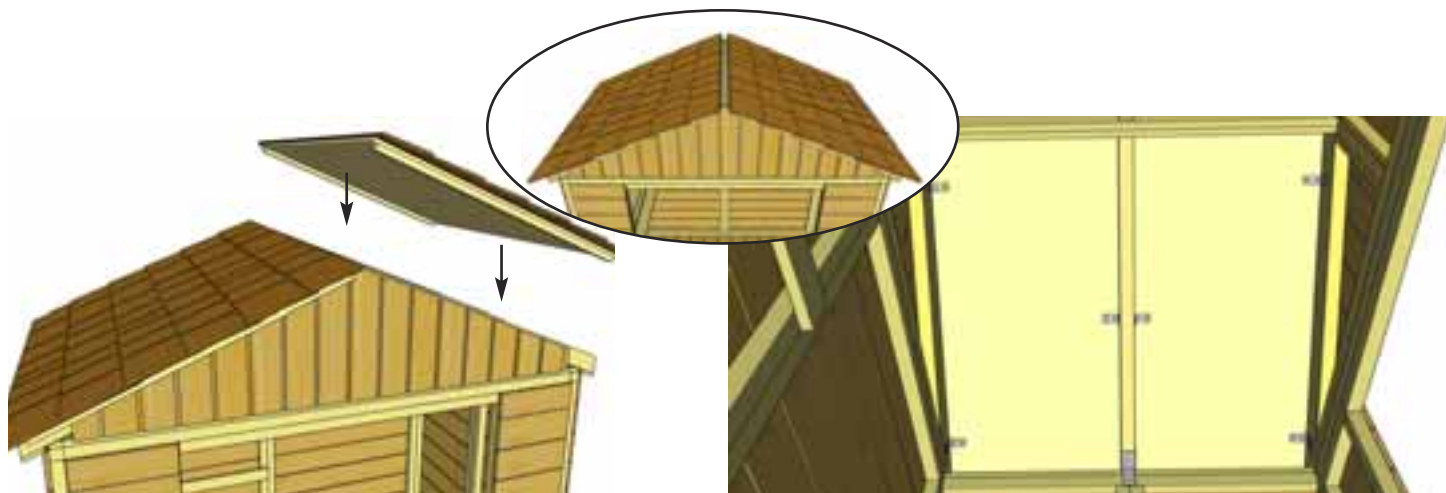

D4. Place second Roof Panel on Rafters and secure inside as per Steps D1 - D2.

Alternate Ridge Cap seams (offsetting angle cut at peak)

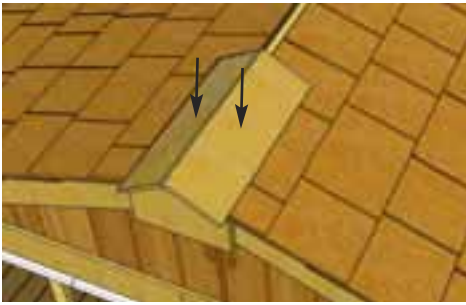

Important: Butt (thick) end of Ridge Cap will be facing towards the outside of shed.

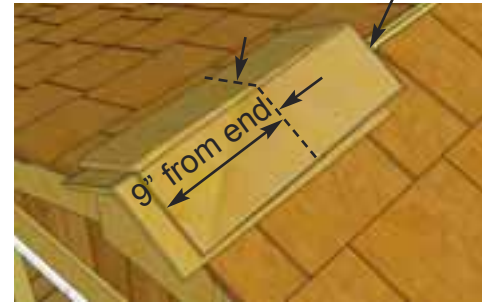

Thin End

D5. Place 1st **Roof Ridge Cap** on roof peak overhanging shingles by approximately 1". Attach with 2 - 1 1/2" **Shingle Nails** 9" from end. Place 2nd Ridge Cap 1" back from first cap. Attach with 2 - 1 1/2" **Shingle Nails** 9" from end. Alternate each Ridge Cap seam as you proceed.

Parts (Steps D5-D6)
Roof Ridge Caps x 8
Ridge Cap Short x 1

Hardware (Steps D5-D6)
1 1/2" Shingle Nails x 20

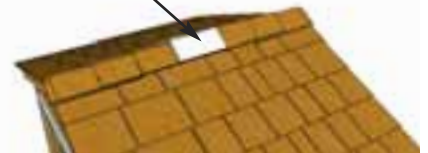
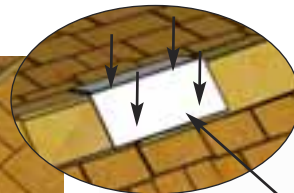
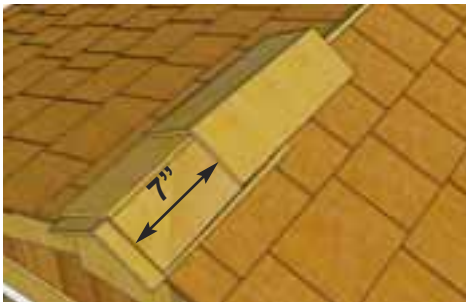

D6. Place 3rd **Ridge Cap** 7" back from 2nd (enough to cover shingle nails). Attach 3rd Ridge Cap as per **Step D5**. Continue to position and attach Ridge Caps until half the roof is complete. From opposite side, position and attach Ridge Caps as described above. One Ridge Cap is cut shorter to fit in the center of the roof. Attach center cap with 4 - 1 1/2" **Shingle Nails**.

D. Roof Section - Metal

Exploded view of all parts necessary to complete the Roof Section. Identify all parts prior to starting.

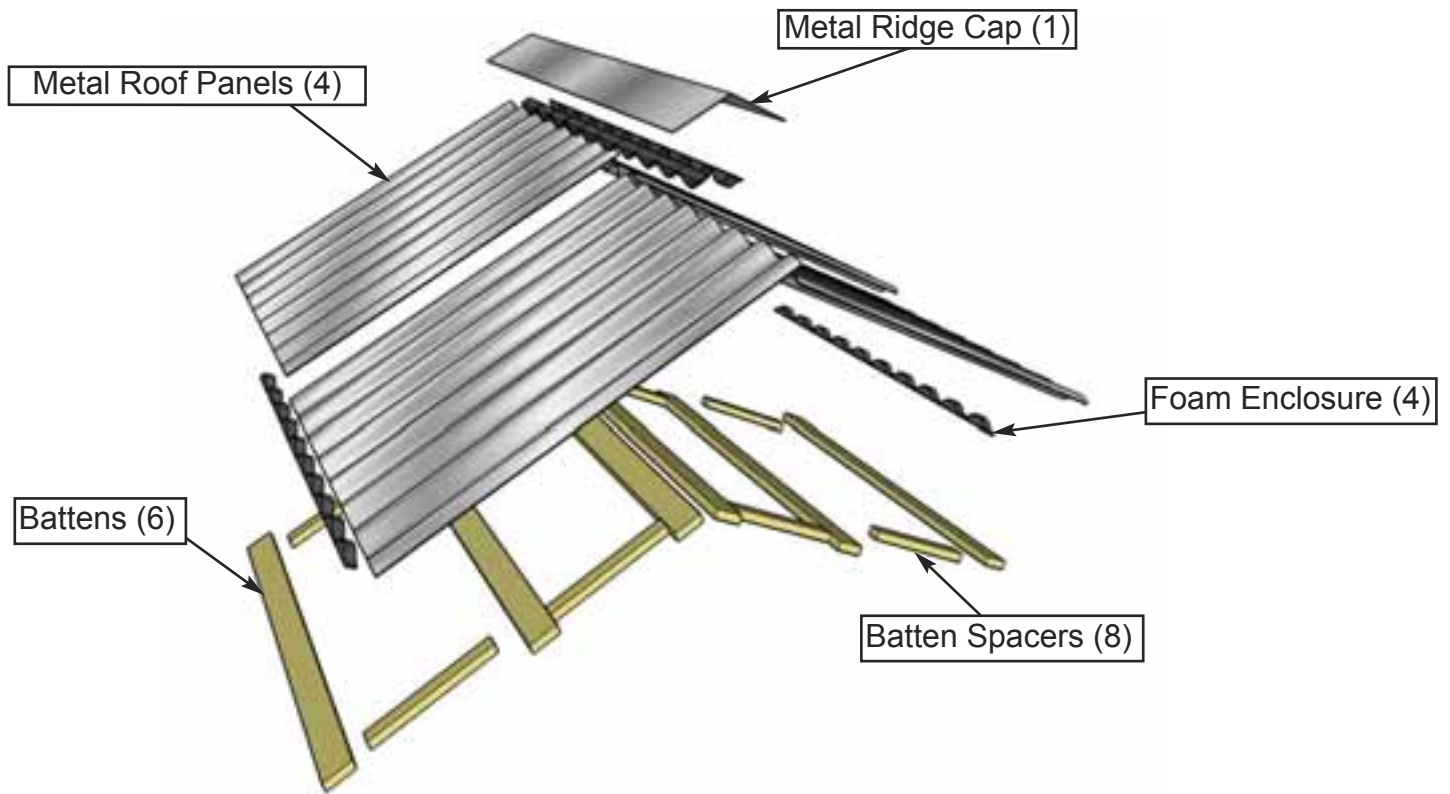

Important: Pre-drill Batten Spacers with 1/8" bit before fastening.

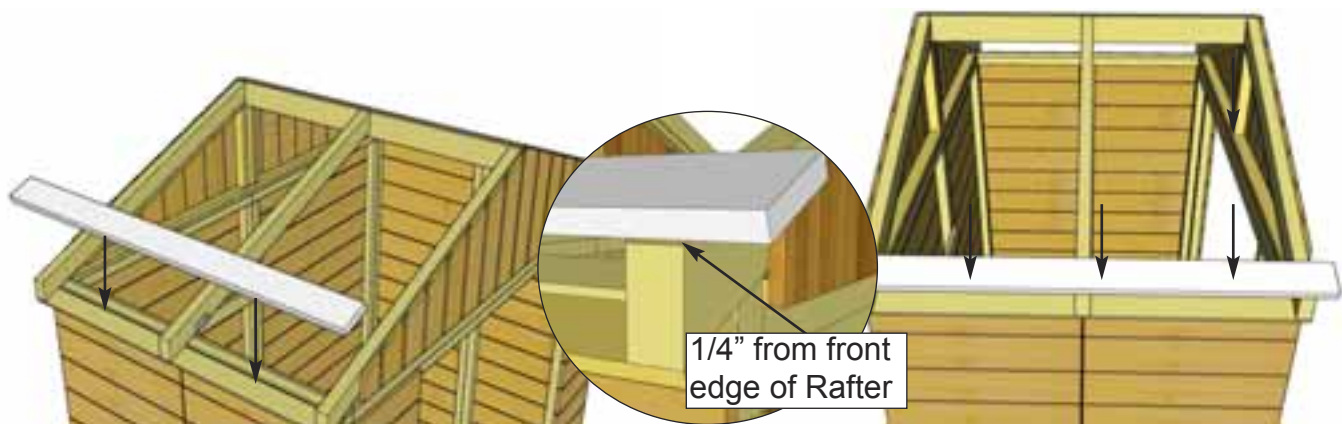

D1. Locate first row of **Roof Batts** and on Rafters 1/4" from front edge. Batten will overhang outside rafters by approximately 2" on each side. Before attaching Batten to rafters, pre-drill pilot hole with 1/8" bit to prevent rafters from splitting. Secure Batten to rafters with **3 - 1 1/4" Brown Screws**. Drill into center of rafter.

Parts (Step D1 - 40)

Batts (3/4" x 3 1/2" x 49") x 6

Batten Spacers (3/4" x 1 1/2" x 15 5/8") x 8

Hardware (Step D1 - 40)

1 1/4" Brown Screws

x 34 total

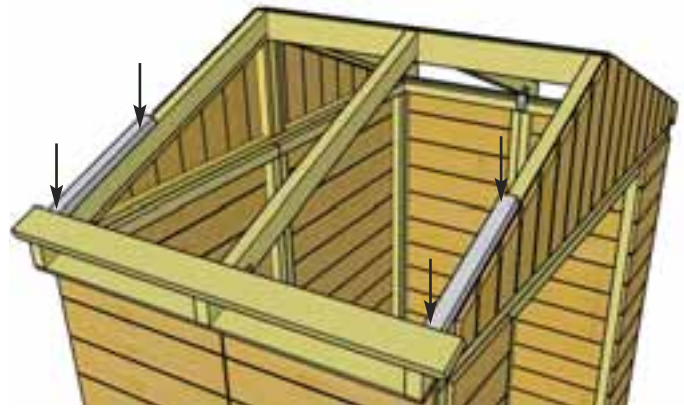
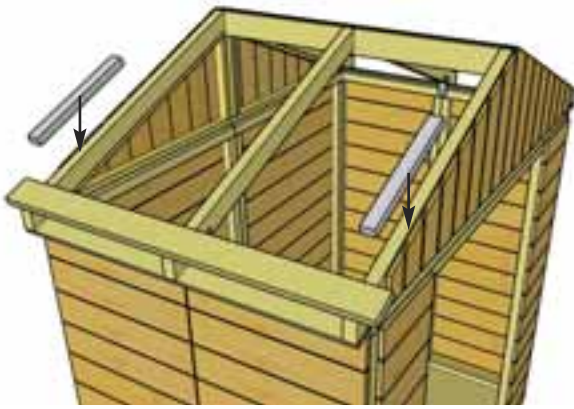

D2. Place 3 **Batten Spacers** against attached Batten, lengthwise along outside Rafters. Ensure Batten Spacer is tight with Batten. Attach Batten Spacer to top of Rafter using 2 - 1 1/4" **Brown Screws**. Batten Spacers are flush with Rafter edges.

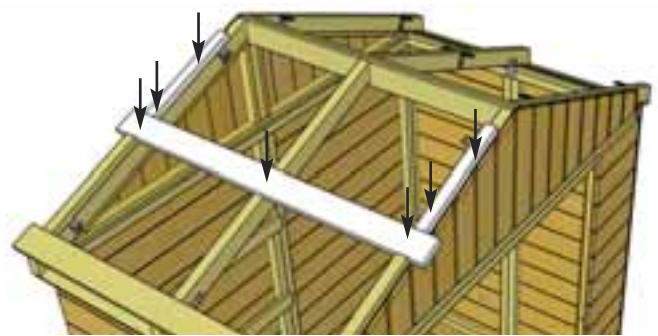

D3. Locate another **Roof Batten** and position flush with previously attached Batten Spacers. Attach with 3 - 1 1/4" **Brown Screws**, into Rafters. Attach a second row of **Batten Spacers** flush with the edge of this middle Batten row via the same method as **Step D1**.

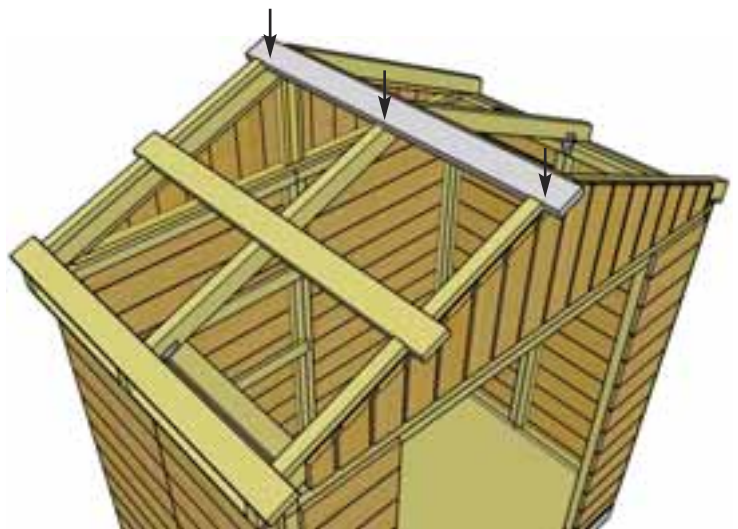

D4. Locate the last **Roof Batten** and attach flush with previously attached **Batten Spacers** via the same method as **Step D1**, using a total of 3 - 1 1/4" **Brown Screws**.

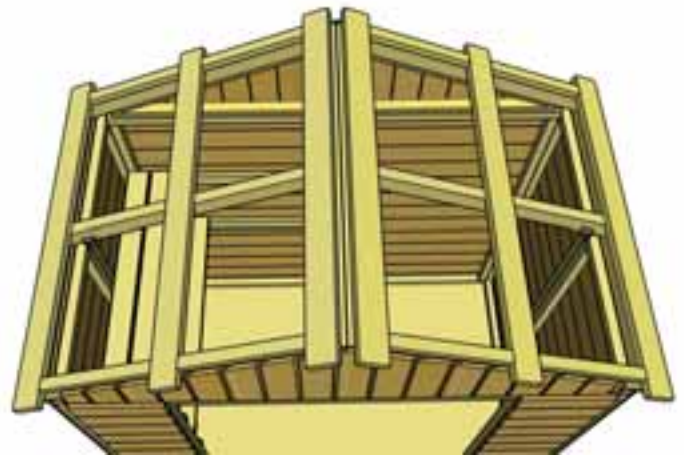
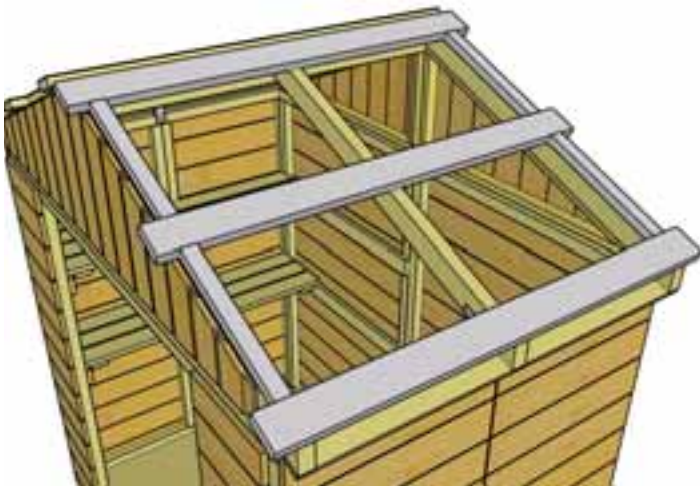

D5. Complete opposite side of roof using remaining **Battens** and **Batten Spacers** by following Steps D1 - D4



Overhang by 2"

Bead of Caulking

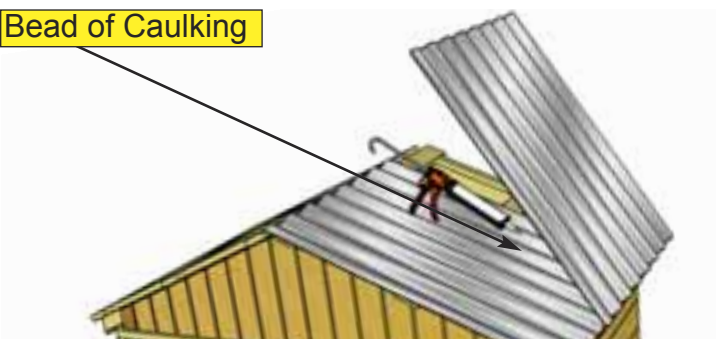

D6. Starting on one side, locate two **Metal Roof Panels** and place on **Battens**. Overhang the **Metal Roof Panels** past the **Battens** on the sides by approximately 2". Panels will overlap. Once **Metal Roof** is spaced correctly from side-to-side and top-to-bottom, lift panels up and run a bead of caulking down the overlapping seams of each panel to seal the joints. You will likely need assistance from a helper in this step.

Parts
Metal Roof Panel (43") x 2

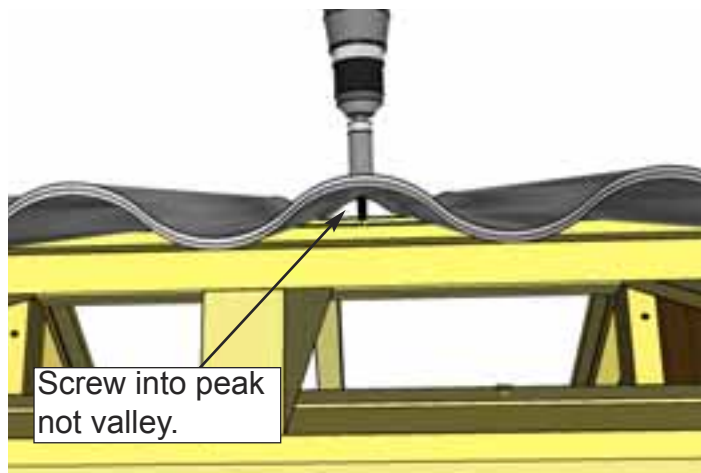
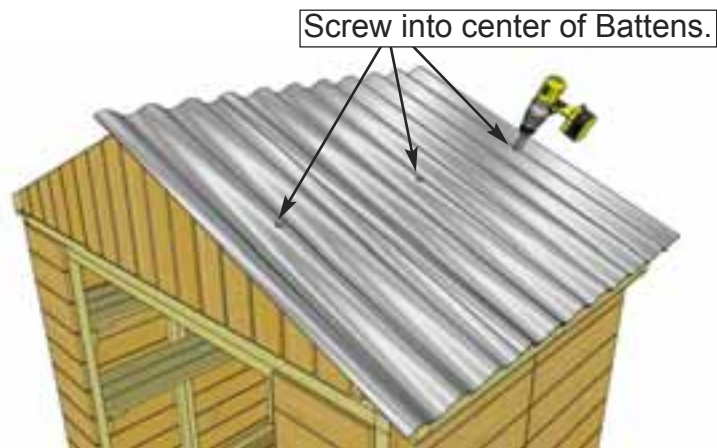

D7. Using 3 - 2" Metal Roof Screws and 1/4" Nut Driver (included), secure Metal Roof Panels down to middle Batten row. Metal screw is self-tapping, do not overtighten. Screw through Roof Panels into center of Batten.

Parts
 1 1/2" Metal Roof Screws
 x 3
 1/4" Nut Driver
 x 1

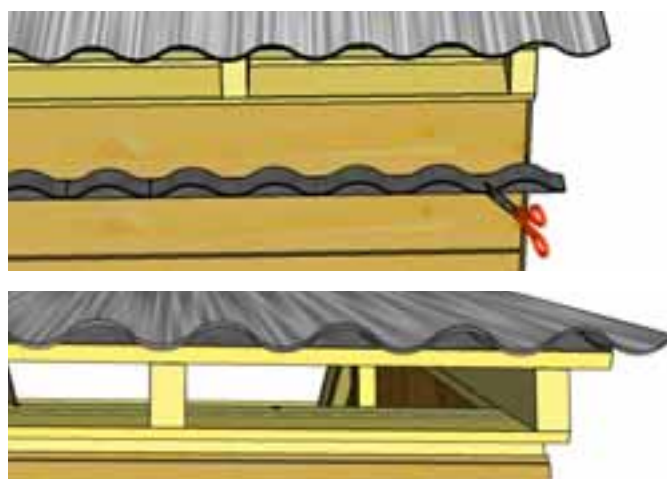
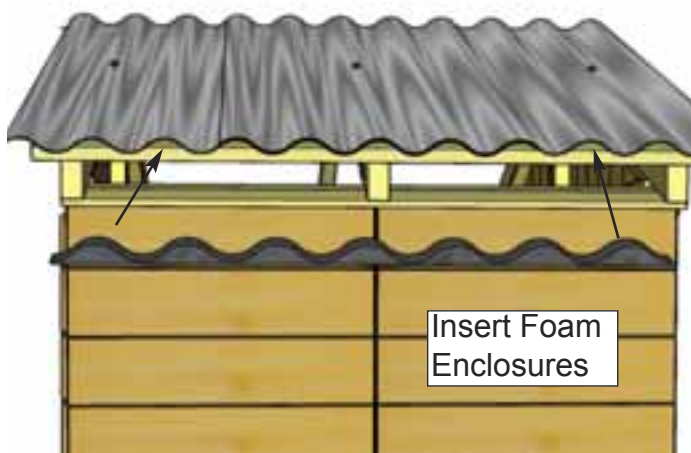

D8. Insert Foam Enclosures between Metal Roof Panels and Battens at the side. Enclosures may need to be snipped down in length to fit. Enclosures will prevent moisture and unwanted bugs, etc. from entering your shed through here.

Parts
 Foam Enclosures
 x 2



D9. Using 3 - 2" Metal Roof Screws and 1/4" Nut Driver, secure Metal Roof Panels down to lower Battens. Metal screws are self-tapping, do not overtighten!

Hardware
1 1/2" Metal Roof Screws x 3
1/4" Nut Driver x 1

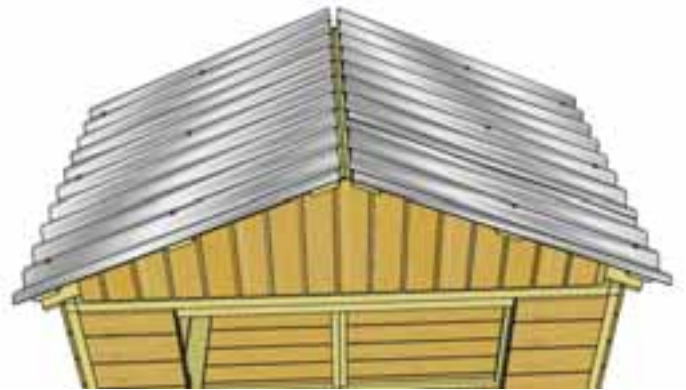

D10. Complete the opposite side of the Roof with 2 remaining Metal Roof Panels and 2 Foam Enclosures, following Steps D6 - D9.

Parts
Metal Roof Panel (43") x 2
Foam Enclosures x 2

Hardware
1 1/2" Metal Roof Screws x 6
1/4" Nut Driver x 1

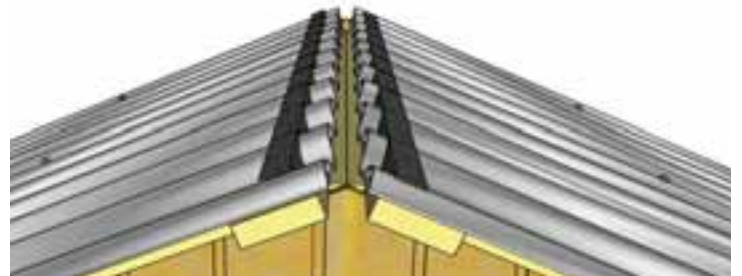

D11. Before attaching Metal Ridge Cap, place strips of Foam Enclosures near to top. Foam Enclosures will prevent moisture from coming in from the top. Complete for both sides.

Parts
Foam Enclosures x 2

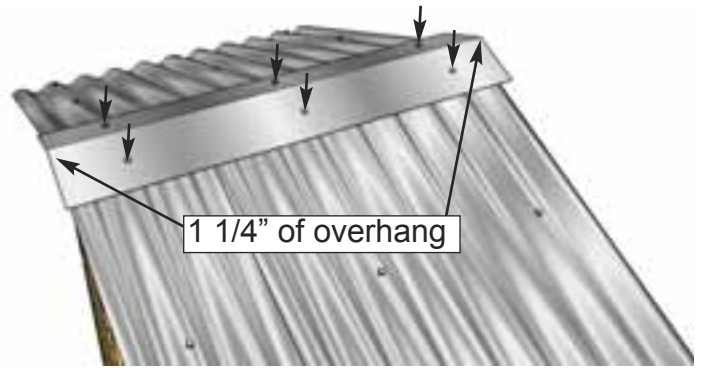

D12. Place **Metal Ridge Caps** on apex of roof. Evenly space from front to back. **Metal Ridge Caps** will overlap each other. Overhang the cap by approximately 1-2" past each end.

<u>Parts</u>	<u>Hardware</u>
Metal Roof Ridge Cap x1 (54")	1 1/2" Metal Roof Screws x 6 1/4" Nut Driver x 1



D13. Attach **Facia Nailing strips** (3/4" x 1 1/4" x 40") to the underside edge of **Roof Battens** with **3 - 1 1/4"** screws per piece. **Nailing Strip** will make it easier to attach Front and Rear Facia in **Step E**. Complete front and rear strips (4 pieces total).

<u>Parts</u>	<u>Hardware</u>
Roof Nailing Strips (3/4" x 1 1/4" x 40") x 4	1 1/4" Screws x 12 total

E. Miscellaneous Section

Exploded view of all parts necessary to complete the Skirting, Trim, Fascia and Miscella-

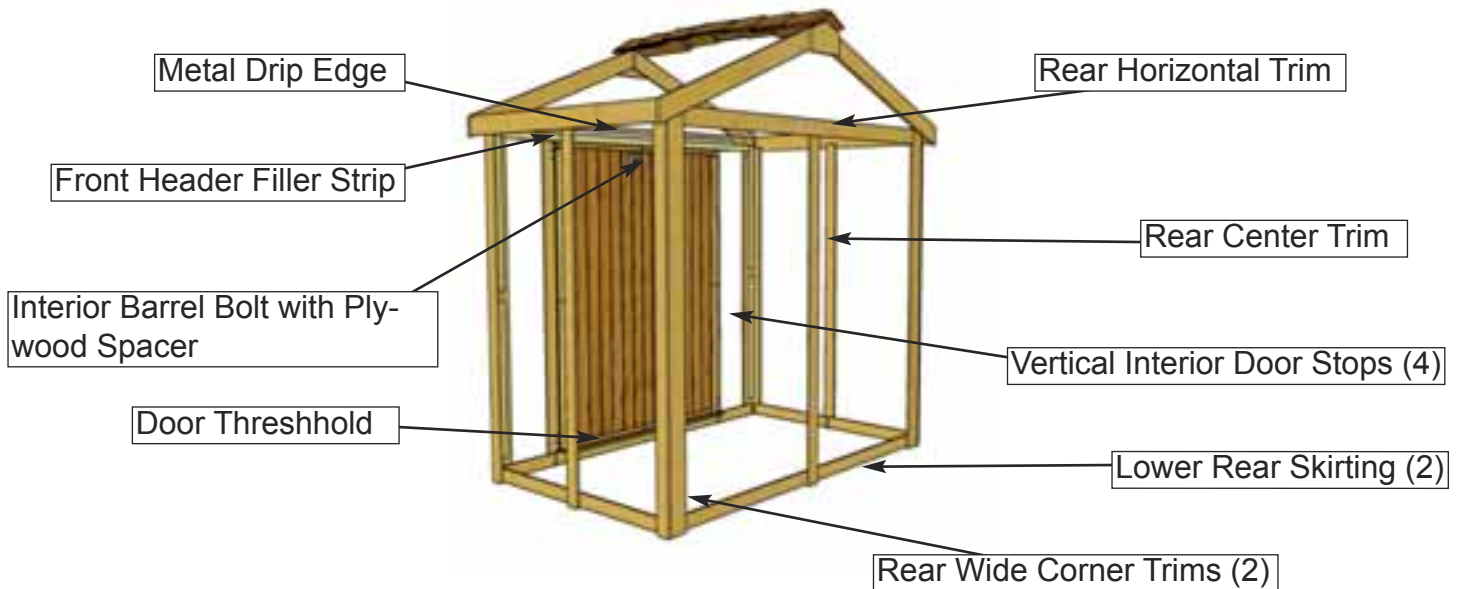
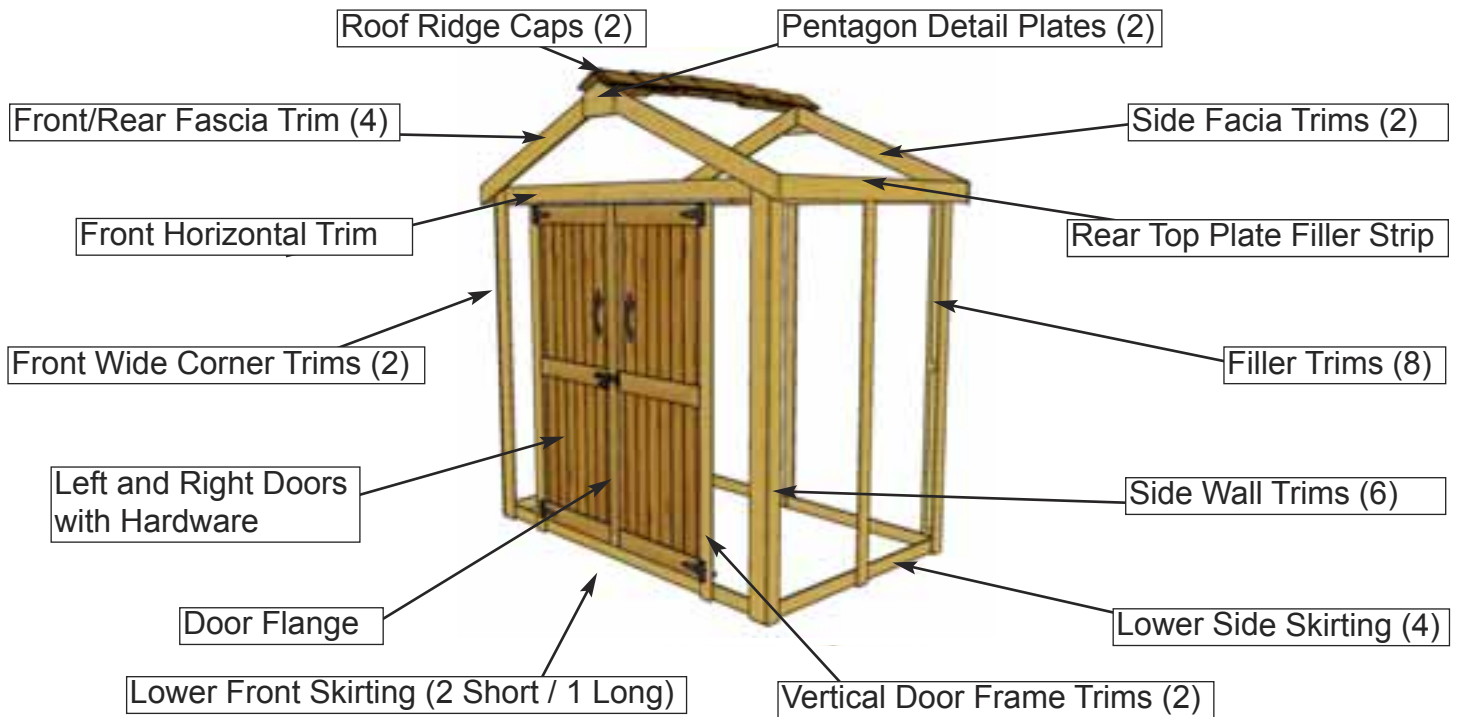

E1. Check the wall seams for visible gaps prior to attaching Filler Trim and apply caulk where needed. Caulking gaps will help prevent moisture from entering and will help the longevity of your shed. **Caulking not included in kit.**

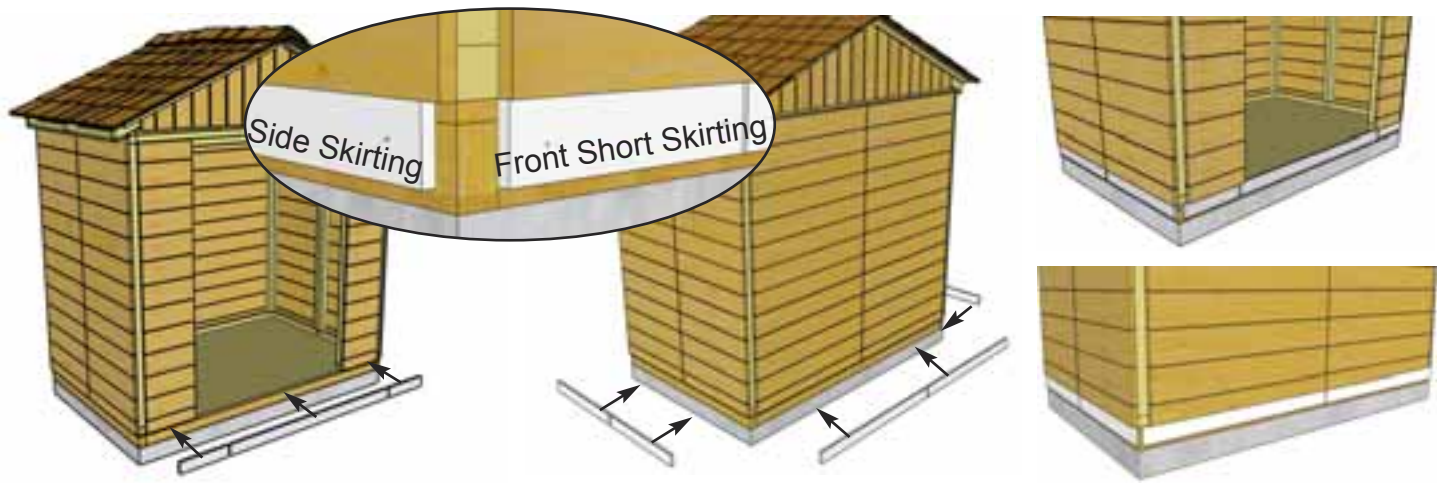

E2. Locate **Lower Front Skirting (2 Short and 1 Long)**. Skirting will hide floor framing. Gaps will be covered by Wide Trim pieces later. Attach 2 Lower Short Front Skirting pieces with 2 - 1 1/2" Finishing Nails per piece. Attach Lower Front Long Skirting with 4 - 1 1/2" Finishing Nails. Locate Lower Side and Rear Skirting and attach with 3 - 1 1/2" Finishing Nails per piece.

<p><u>Parts</u></p> <p>Lower Front Skirting Short (1/2" x 2 1/2" x 11 3/4") x 2 Long (1/2" x 2 1/2" x 47") Lower Side Skirting (1/2" x 2 1/2" x 21 3/4") x 4 Lower Rear Skirting (1/2" x 2 1/2" x 35 3/4") x 2</p>	<p><u>Hardware</u></p> <p>1 1/2" Finishing Nails x 26 total</p>
---	--



E3. Locate 4 **Front Filler Trims**. Filler trim will be covered by Corner Trim in **Step E6**. Attach in each front corner with 3 - 1 1/2" Finishing Nails per piece.

<p><u>Parts (Step E3 - E4)</u></p> <p>Front/Rear Filler Trims (5/8" x 1 1/2" x 30") x 8 total</p>	<p><u>Hardware (Step E3 - E4)</u></p> <p>1 1/2" Finishing Nails x 24 total</p>
---	---



Gaps will be covered.



E4. Position and attach **Rear Filler Trims** in the rear as per **Step E3**.

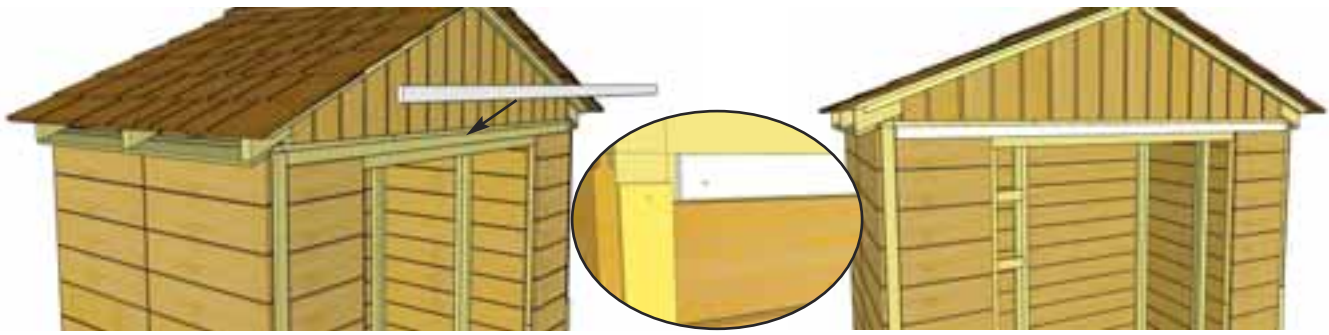

E5. Locate **Front Header Filler Strip**. Position Front Header Filler Strip onto Front Header. Evenly space from side to side. Secure with **6 - 1 1/2" Finishing Nails** into Front Header.

<p><u>Parts</u> Front Header Filler Strip (5/8" x 1 1/2" x 69 1/2")</p>	<p><u>Hardware</u> 1 1/2" Finishing Nails x 6 total</p>
--	--



Expert Advice:
 Do a dry run with Front and Rear Corner Trims before attaching. Confirm the rough face is configured correctly and small trim gaps are satisfactory before attaching.

Align bottoms of both Corner Trim pieces flush.

Front Corner Trim 3 1/2" wide.

Front Side Corner Trim 2 1/2" Wide.

E6. Locate a **Front Wide Corner Trim** and **Side Wall Trim**. Starting in one corner, position both Trims up underneath Cedar Roof and Soffit. Align Front Wide Corner Trim with bottom of Side Corner Trim. Side Corner Trim will cap Front Wide Corner Trim. When correctly aligned, attach each piece with **6 - 1 1/2" Finishing Nails**.

<p><u>Parts</u> Front Wide Corner Trim (1/2" x 3 1/2" x 67 7/8") Side Wall Trim (1/2" x 2 1/2" x 65 1/2")</p>	<p><u>Hardware</u> 1 1/2" Finishing Nails x 12 total</p>
---	---

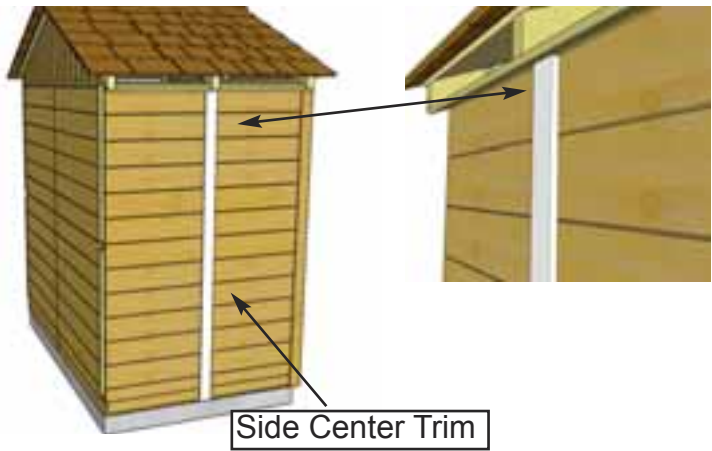

E7. Locate **Side Wall Trim**. Place in the center of the two side walls. Attach trim close to the roof soffit with **6 - 1 1/2" Finishing Nails**.

<u>Parts</u> Side Wall Trim (1/2" x 2 1/2" x 65 1/2")
<u>Hardware</u> 1 1/2" Finishing Nails x 6 total

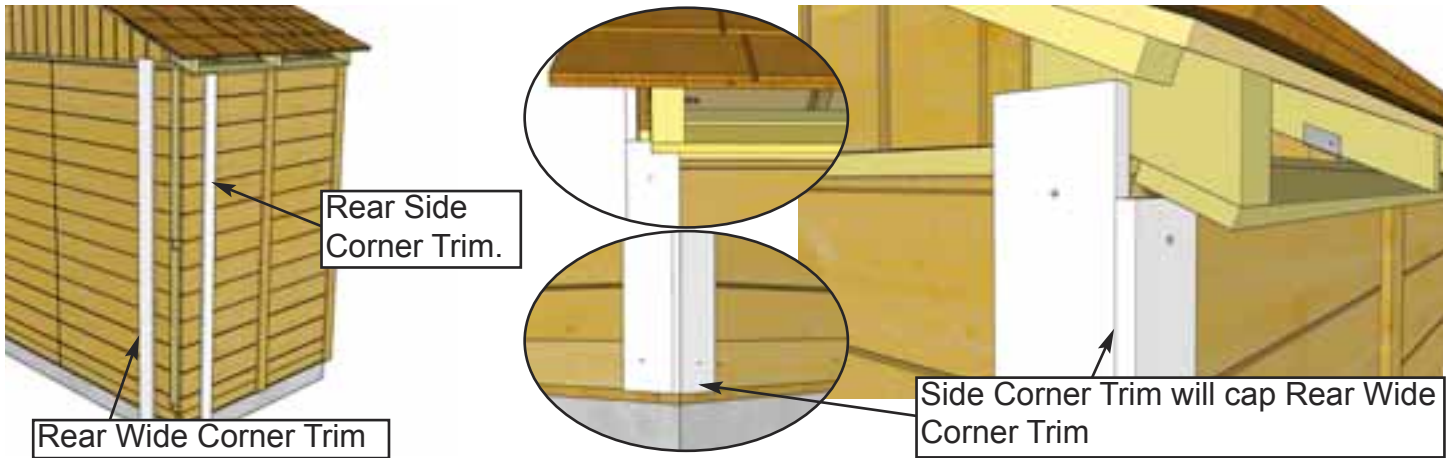

E8. Locate a **Side Wall Trim** and **Rear Wide Corner Trim** and position both Trims up underneath Cedar Roof and Soffit. Align **Rear Wide Corner Trim** with bottom of **Side Corner Trim**. **Side Corner Trim** will cap **Rear Wide Corner Trim**. When correctly aligned, attach each piece with **6 - 1 1/2" Finishing Nails**.

<u>Parts</u> Rear Wide Corner Trim (1/2" x 3 1/2" x 67 7/8") Side Wall Trim (1/2" x 2 1/2" x 65 1/2")	<u>Hardware</u> 1 1/2" Finishing Nails x 12 total
---	--

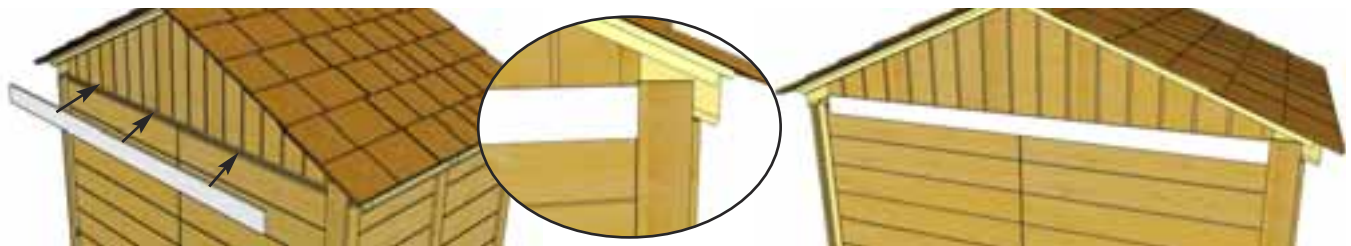

E9. Locate **Upper Rear Horizontal Trim** and align tight against **Rear Wide Corner Trim**. Attach with **6 - 1 1/2" Finishing Nails**.

<u>Parts</u> Upper Rear Horizontal Trim (1/2" x 3" x 67 1/4")	<u>Hardware</u> 1 1/2" Finishing Nails x 6 total
--	---

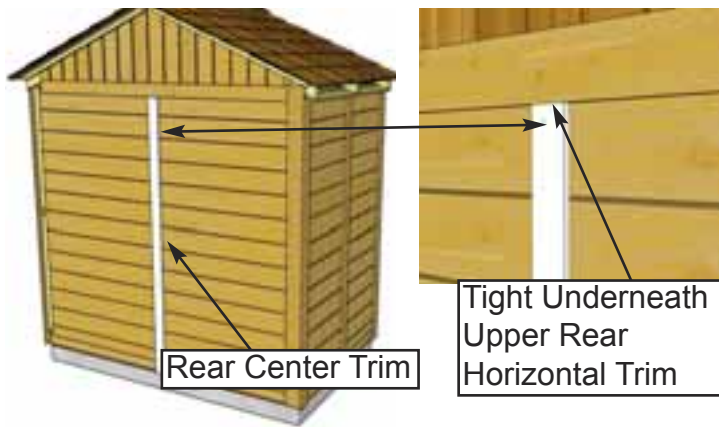

E10. Locate **Rear Center Trim**. Align tight against **Upper Rear Horizontal Trim** and attach with **6 - 1 1/2" Finishing Nails**.

<u>Parts</u> Rear Center Trim (1/2" x 2 1/2" x 64 3/4")
<u>Hardware</u> 1 1/2" Finishing Nails x 6 total



E11. Complete other **Rear and Front Corner Trims** as per **Steps E6 - E8**.

<u>Parts</u> Front/Rear Wide Corner Trim x 2 (1/2" x 3 1/2" x 67 7/8") Side Wall Trim x 3 (1/2" x 2 1/2" x 65 1/2")	<u>Hardware</u> 1 1/2" Finishing Nails x 30 total
---	--

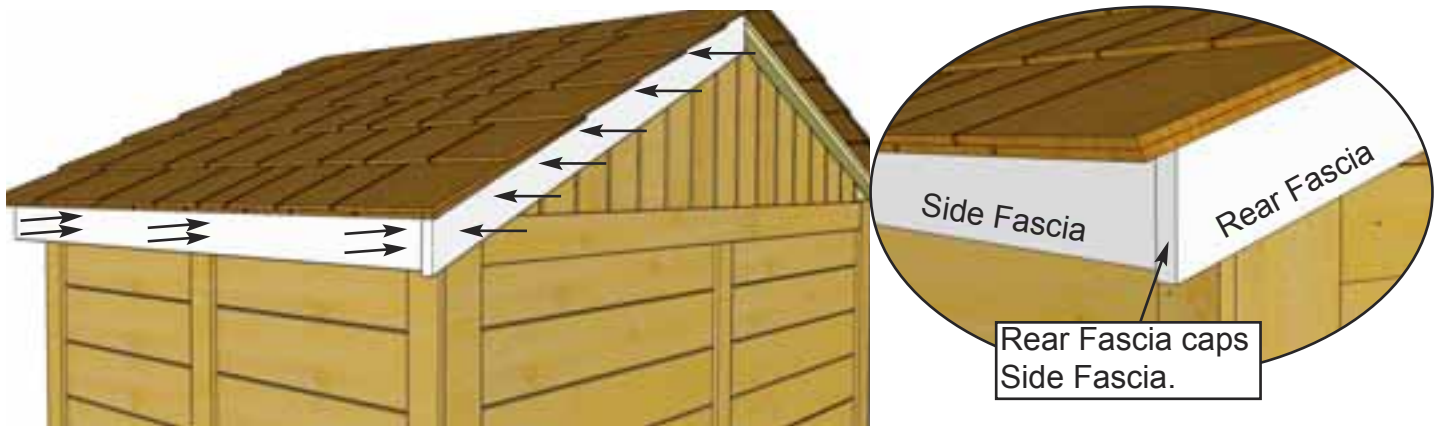

E12. Position **Rear Fascia** (angle cut on ends) and **Side Fascia** (square cut ends) in corner. Line Fascia up so Rear Fascia caps Side Fascia. Attach Rear Fascia to Nailing Strip with **6 - 1 1/2" Finishing Nails** and Side Fascia to ends of Rafters with **6 - 1 1/2" Finishing Nails**. Gap where Fascia boards come together at peak will be covered in Step E13. Do a dry run using Side Fascia to help you correctly position before attaching.

<p>Parts (Steps E12 - E13) Front & Rear Fascia (Angle Cut Both Ends) x 4 (3/4" x 3 1/2" x 43") Side Fascia x 2 (3/4" x 3 1/2" x 49")</p>	<p>Hardware (Steps E12 - E13) 1 1/2" Finishing Nails x 36 total</p>
--	---

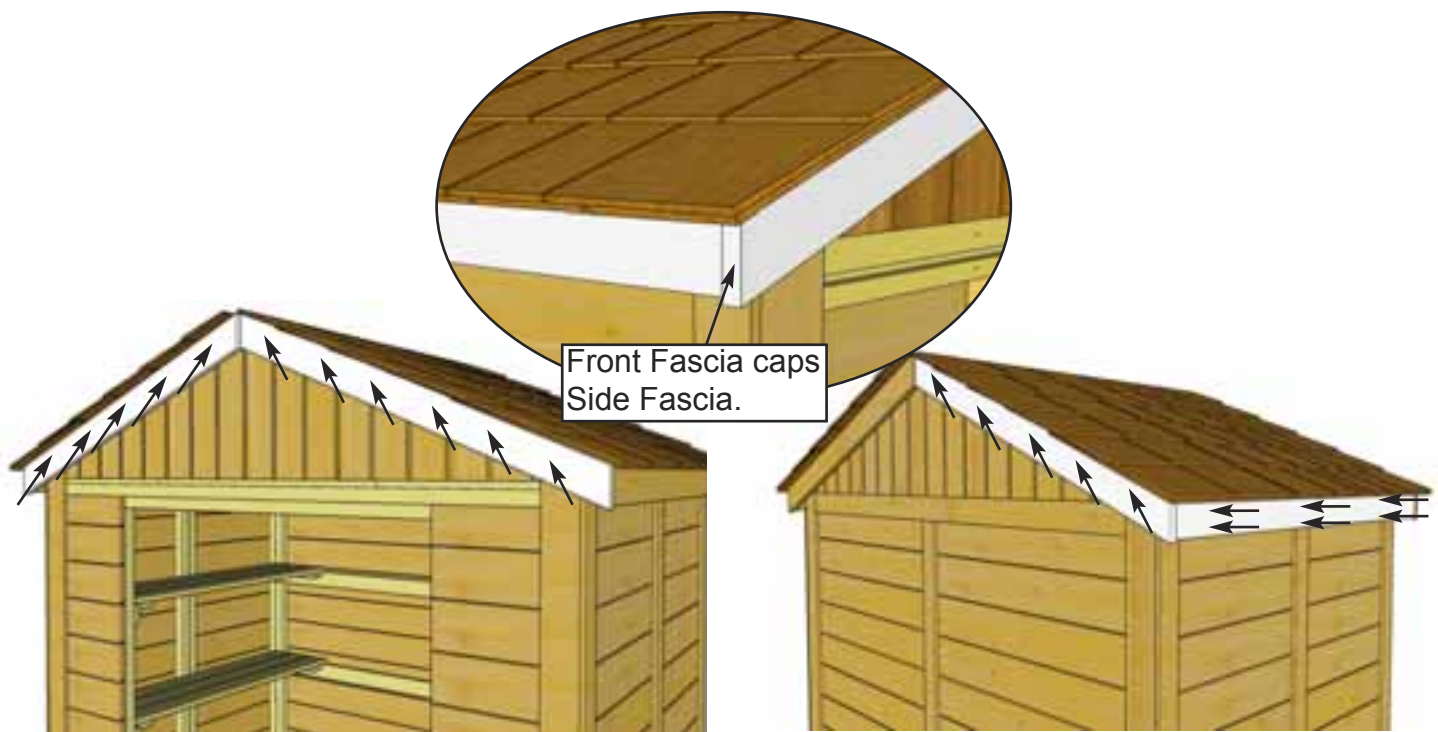

E13. Attach remaining **Front and Rear Fascia** to Nailing Strips and attach remaining **Side Fascia** to Rafter ends as per **Step E12**.



E14. Attach **Pentagon Detail Plates** where Front and Rear Fascia Trims meet at the peak. Secure with **4 - 1 1/2" Finishing Nails** per piece.

<u>Parts</u> Pentagon Detail Plates (1/2" x 5 1/2" x 8") x 2	<u>Hardware</u> 1 1/2" Finishing Nails x 8 total
---	--

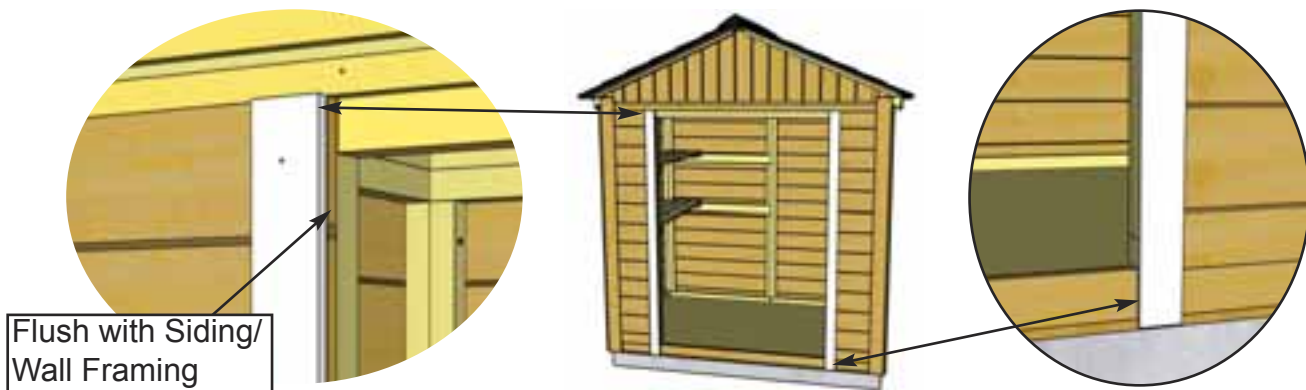

E15. Locate **2 Vertical Door Frame Trims**. Position on Front Narrow Wall flush with Wall siding/ framing and underneath Front Header Filler Strip. Attach with **6 - 1 1/2" Finishing Nails**.

<u>Parts</u> Vertical Door Frame Trims (1/2" x 2 1/2" x 64 1/4") x 2	<u>Hardware</u> 1 1/2" Finishing Nails x 12 total
---	--

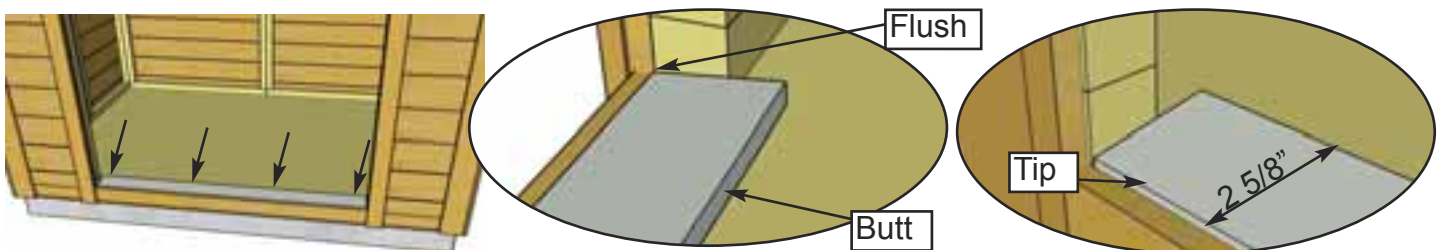

E16. Locate **Door Threshold (Bevel)** and position on Floor at the opening. Align tip of the bevel flush with the outside of Bottom Wall Plate. Attach with **4 - 1 1/4" Brown Screws**

<u>Parts</u> Door Threshold (Bevel) (1/2" x 2 5/8" x 44 7/8")	<u>Hardware</u> 1 1/4" Brown Screws x 4 total
--	--

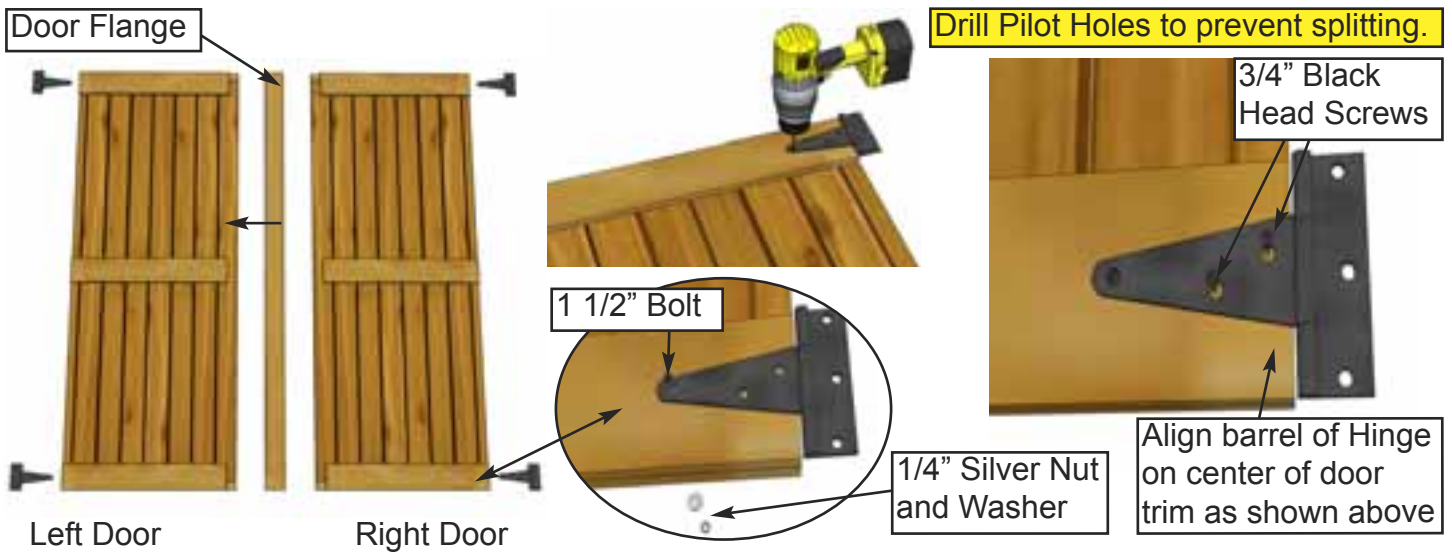

E17. Locate **Left and Right Doors** and **Door Flange**. Orientate Doors so the outside of each Door is facing up. Locate **Black T Hinges**. Prior to attaching, position Hinges equally on Door trim as shown above and with a 1/8" drill bit, drill a hole through the tip of the Hinge and all the way through the Door. Complete for all 4 hinges. Attach each Hinge to Door as above with 1 - 1 1/2" **Black Headed Bolt**, and a 1/4" **Silver Nut and Washer**, using a 3/8" wrench. Finish Hinge by securing with 2 - 3/4" **Black Headed Screws**. Drill small pilot holes first to prevent wood from splitting. Complete both Doors (4 Hinges).

<p><u>Parts (Step E17 - E21)</u> Left and Right Doors (22 1/4" x 61 3/8") Door Flange (1/2" x 2 1/2" x 61 3/8")</p>	<p><u>Hardware (Step E17 - E21)</u> Black T Hinge x 4 total 1 1/2" Black Headed Bolt x 4 total 1/4" Silver Nut and Washer x 4 total 3/4" Black Headed Screws x 8 total 1" Silver Screws x 6 total 2" Black Headed Screws x 12 total</p>
---	---

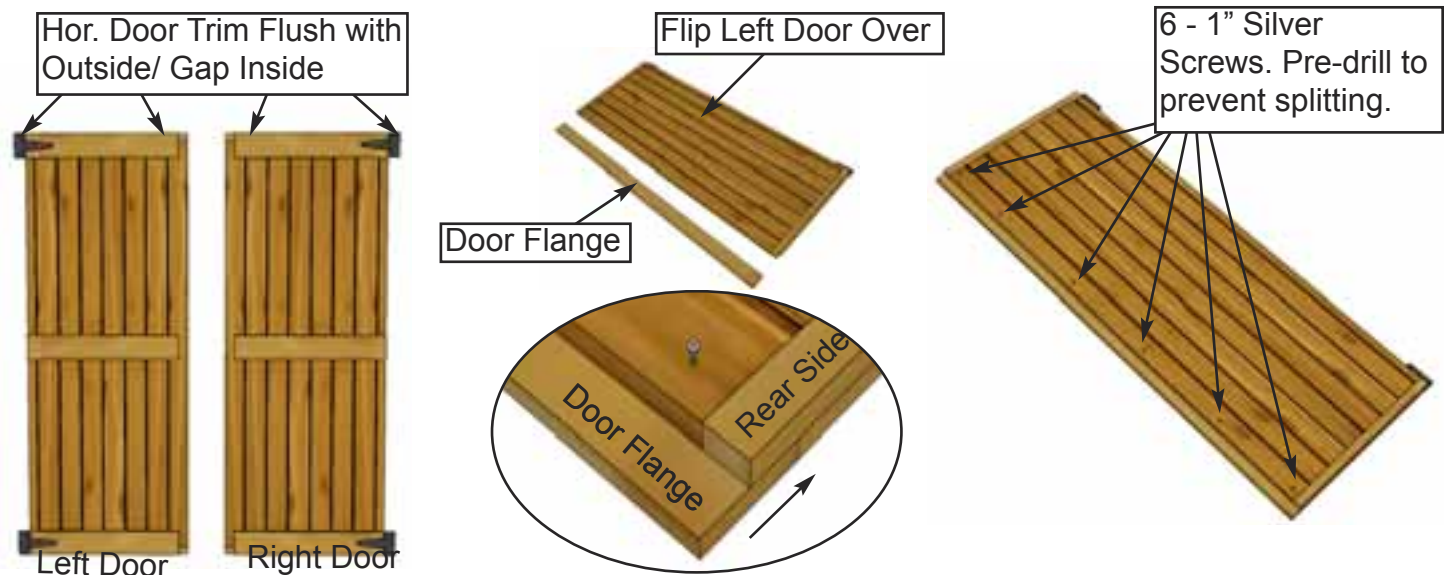

E18. Flip **Left Door** over to attach **Door Flange**. Position Door Flange tight against horizontal trim and even with trim on top and bottom. If out slightly, make sure top horizontal trim and Flange are even. Pre-drill with 1/8" bit to prevent wood from splitting. Attach with 6 - 1" **Silver Screws**.

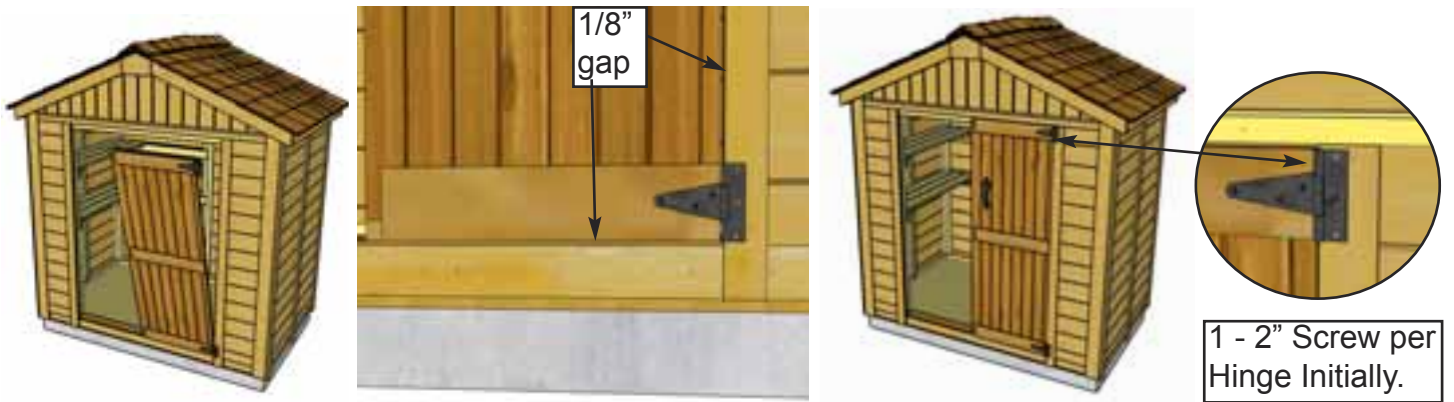

E19. Starting with Right Door first, lift and position Door in opening. Leave a 1/8" gap on right side and 1/8" gap on the bottom. Use a **Cedar Shingle Shim** to shim the Door at bottom to help position door evenly. When Door is aligned correctly, screw Hinge into Vertical Door Frame Trim with **1 - 2" Black Headed Screw**. Use only 1 screw initially per Hinge until both Door alignments are confirmed. Drill pilot holes to prevent wood from splitting.



E20. Position Left Side Door (with Flange) as per **Step E19**. Once again, use only **1 - 2" Black Headed Screw** per Hinge initially to secure door to Vertical Door Frame Trim.

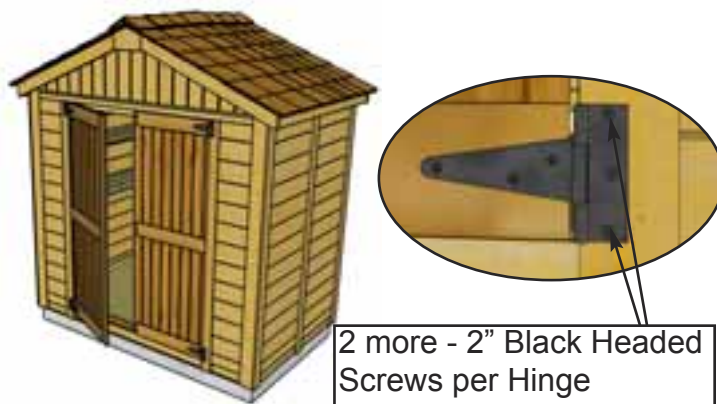

E21. With both Doors partially attached, check to see Doors open and close correctly. Make any necessary adjustments and when satisfied, completely secure Hinges to Vertical Door Frame Trim with **two more 2" Black Headed Screws** per Hinge. Drill pilot holes to prevent wood from splitting.



E22. Attach **Door Handles** to Doors with **4 - 3/4" Black Headed Screws** per Handle. Choose desired Handle height.

Hardware
Black Handle x 2 total
3/4" Black Headed Screws x 8 total

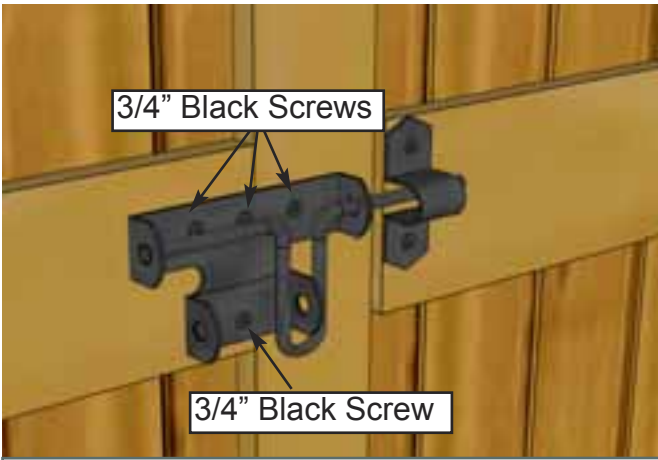

Important: Drill shallow Pilot Holes to prevent splitting.

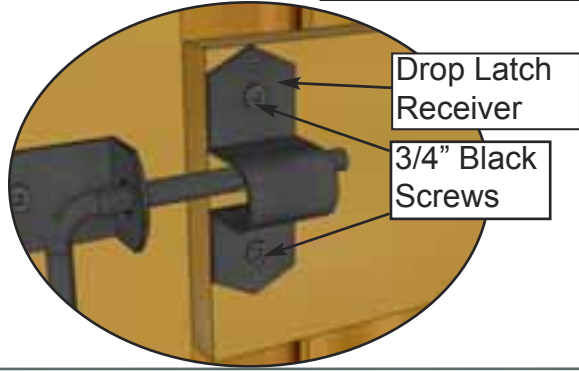

E23. Attach **Black Drop Latch** as illustrated above with 6 - **3/4" Black Headed Screws**.
Note: Black Drop Latch receiver is positioned higher than male. Do a dry run first to position Black Drop Latch correctly. **Important** - Drill pilot holes with 1/8" drill bit prior to securing with screws to prevent wood splitting.

Hardware
Black Drop Latch
3/4" Black Headed Screws x 6 total

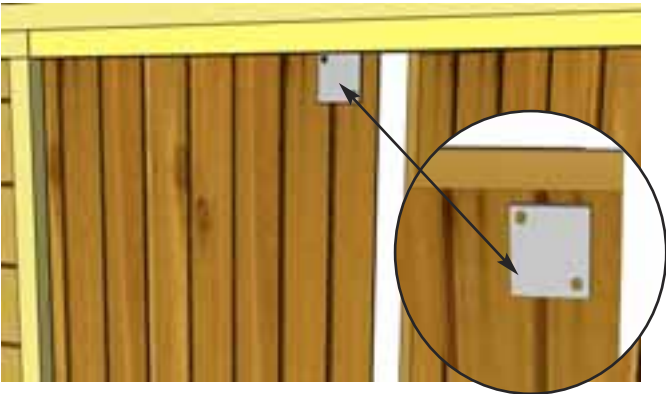

E24. Install the **Plywood Spacer** to interior Door frame approximately 1 1/2" from top of Door frame and 1" from edge, as pictured. Use 2 - 1 1/4" **Brown Screws** to secure. Plywood Spacer should fit flush underneath Interior Door Header when Door is closed.

Hardware
Plywood Spacer (1/2" x 2 1/2" x 2 1/2")
1 1/4" Brown Screws x 2 total



E25. Position the **Interior Silver Barrel Bolt** on the Plywood Spacer and attach with 4 - **3/4" Silver Screws**. Tap Silver Barrel Bolt with hammer on underside of Interior Door Header to mark location.

Hardware
Interior Silver Barrel Bolt
3/4" Silver Screws x 4 total



E26. Open Door and drill out marked Silver Barrel Bolt impression with a 3/8" Drill Bit. Close Door, slide Interior Silver Barrel Bolt in drilled hole to confirm fit.

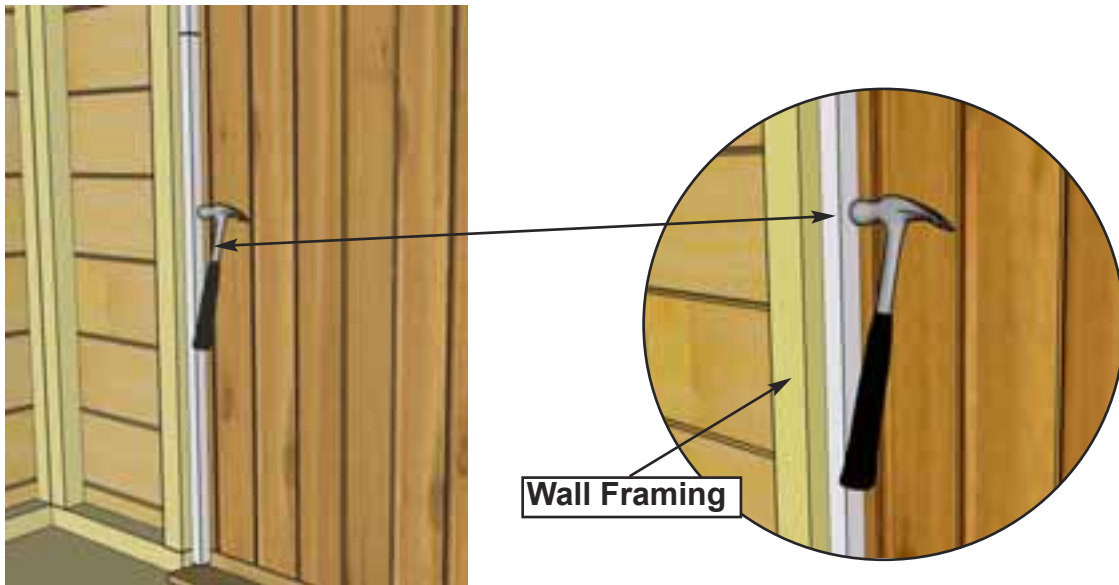

E27. Attach Interior Vertical Door Stops to inside Wall framing with 4 - 1 1/2" Finishing Nails per piece. To align correctly, close Door to make sure Stops are close to the Door but don't interfere with their closing. Attach bottom piece first with hammer.

<p><u>Parts (Step E26 - E27)</u> Interior Vertical Door Stops x 4 (3/4" x 3/4" x 29 7/8")</p>	<p><u>Hardware (Step 66 - 67)</u> 1 1/2" Finishing Nails x 16 total</p>
--	--

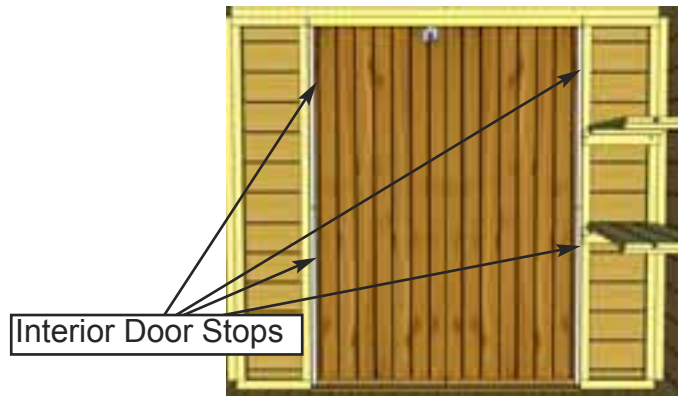

E28. Attach top Interior Door Stop as per Step E26 and then complete the opposite side.



E29. Locate Front Horizontal Trim and Metal Drip Edge. Position Metal Drip Edge behind Door Trim. Evenly space from side to side. While holding down both Metal Drip Edge and Front Horizontal Trim, secure with 6 - 1 1/2" Finishing Nails into Front Header Filler Strip.

Parts	Hardware
Front Horizontal Trim (1/2" x 3" x 67 1/4") Metal Drip Edge (60")	1 1/2" Finishing Nails x 6 total



Outdoor Living Today



Congratulations on assembling your 6x4 Space Master!

Note: Our Sheds are shipped as an unfinished product. If exposed to the elements, the lumber will weather to a silvery-gray color. If you prefer to keep the lumber looking closer to the original color, we suggest that you treat the wood with a good oil base wood stain. You may also wish to paint your new shed rather than stain it. In both cases we recommend that you consult with a paint and stain dealer in your area for their recommendations.

We hope your experience constructing our 6x4 Space Master has been both positive and rewarding. We value your feedback and would like to hear back from you on how well we are doing in the following areas:

1. Customer Service
2. On Time Shipping
3. Motor Freight Delivery
4. Quality of Materials
5. Assembly Manual
6. Overall Satisfaction



The materials contained in this Assembly Manual may be downloaded or copied provided that ALL copies retain the copyright and any other proprietary notices contained on the materials. No material may be modified, edited or taken out of context such that its use creates a false or misleading statement or impression as to the positions, statements or actions.

Please call, write or email us at:

Canadian Address
9393 287th Street
Maple Ridge, British Columbia
Canada V2W 1L1

United States Address
P.O. Box 96
Sumas, Washington
USA 98295

Toll Line: 1.888.658.1658

Fax: 1.604.462.5333

sales@outdoorlivingtoday.com