

Classic Rocking Chair

NOTE:
DO NOT CUT THE PLASTIC WRAP
AROUND THE BACK FRAME
UNTIL ASSEMBLY
IS COMPLETE.

- Materials:
- (1) Hardware pack
 - (1) Head piece
 - (1) Back frame
 - (1) Seat frame
 - (2) Side frame
 - (1) Front Brace
 - (1) Back Brace
 - (2) Rocker Bottom

TOOLS REQUIRED



Allen Wrench
Included

Phillips Screw-Driver
Not included

Note:

Do not use an impact driver to install hardware.
Use battery operated drill or provided Allen wrench

- (14) A - $\frac{1}{4}$ -20 x 2- $\frac{5}{8}$ " Hex screw



- (4) B - 2" Phillips screw



Step 1:

Set one side frame on the ground with the pockets facing up. Place the head and seat frame into the pockets. Set the back frame onto the side frame

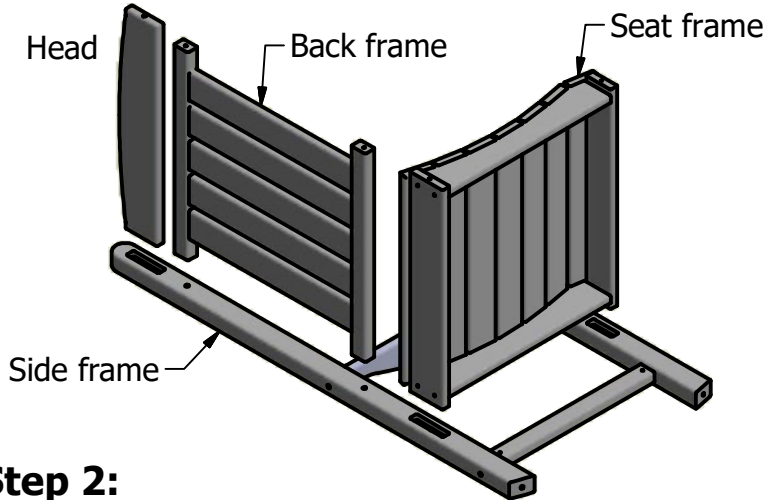

Step 2:

Place the other side frame on top and insert the head and seat frame into the pockets. Also, line up the back frame with the holes of the side frame. Attach using A- screws. Flip and repeat on the other side .

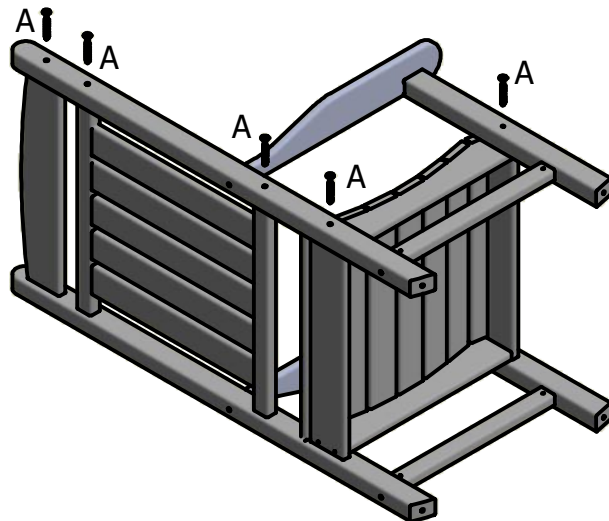

Step 3:

Attach the front and back brace using B- screws.

Note: Back brace has the logo.
It should be facing up towards the back of rocker

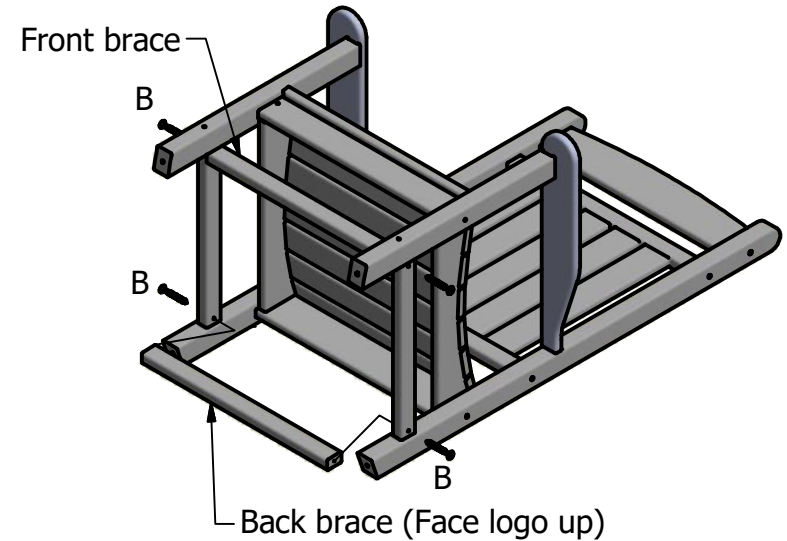

Step 4:

Set rocker on its side.
Attach rocker bottoms with A-screws

