

PART LIST

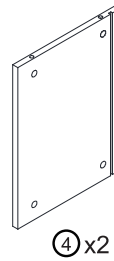

HARDWARE

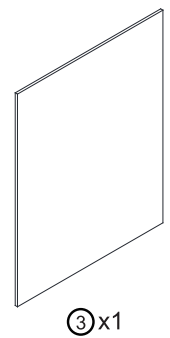
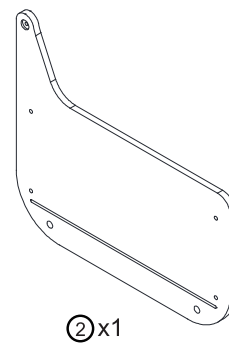
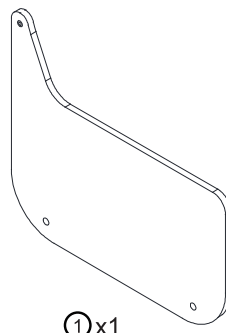
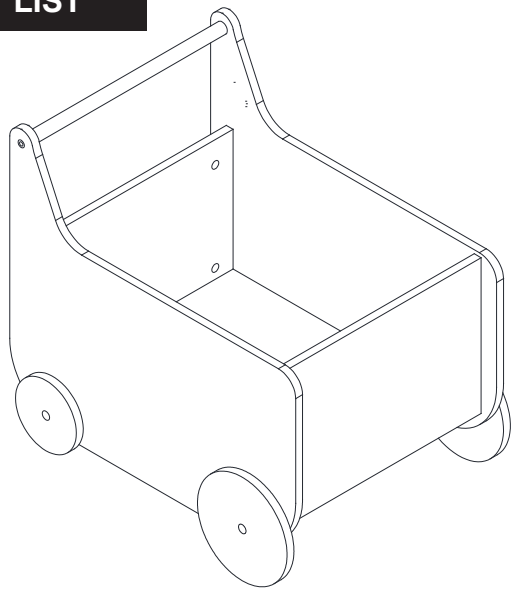

Ax8

Cam Dowels



Cx2

Screws



Ex4

Split Washer

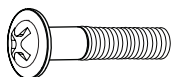

Gx4

Connector



Bx8

Cam Lock



Dx4

Connector



Fx4

Connector

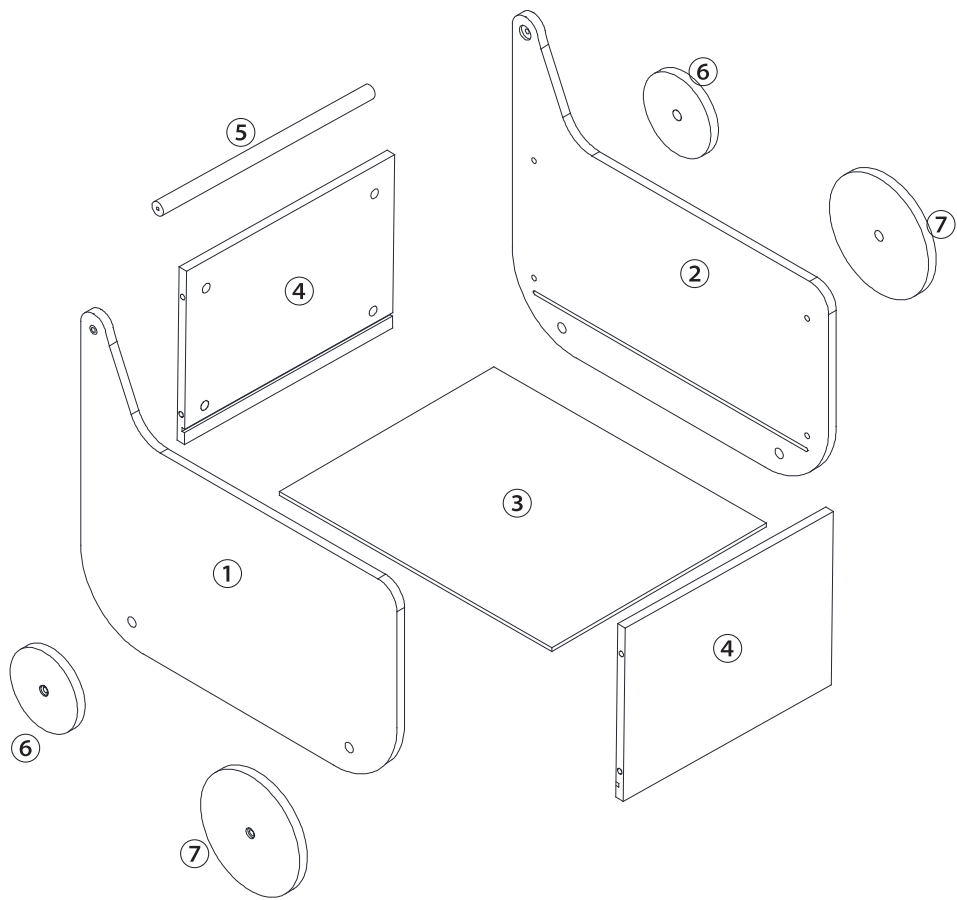

WHEEL ASSEMBLY

Step 1

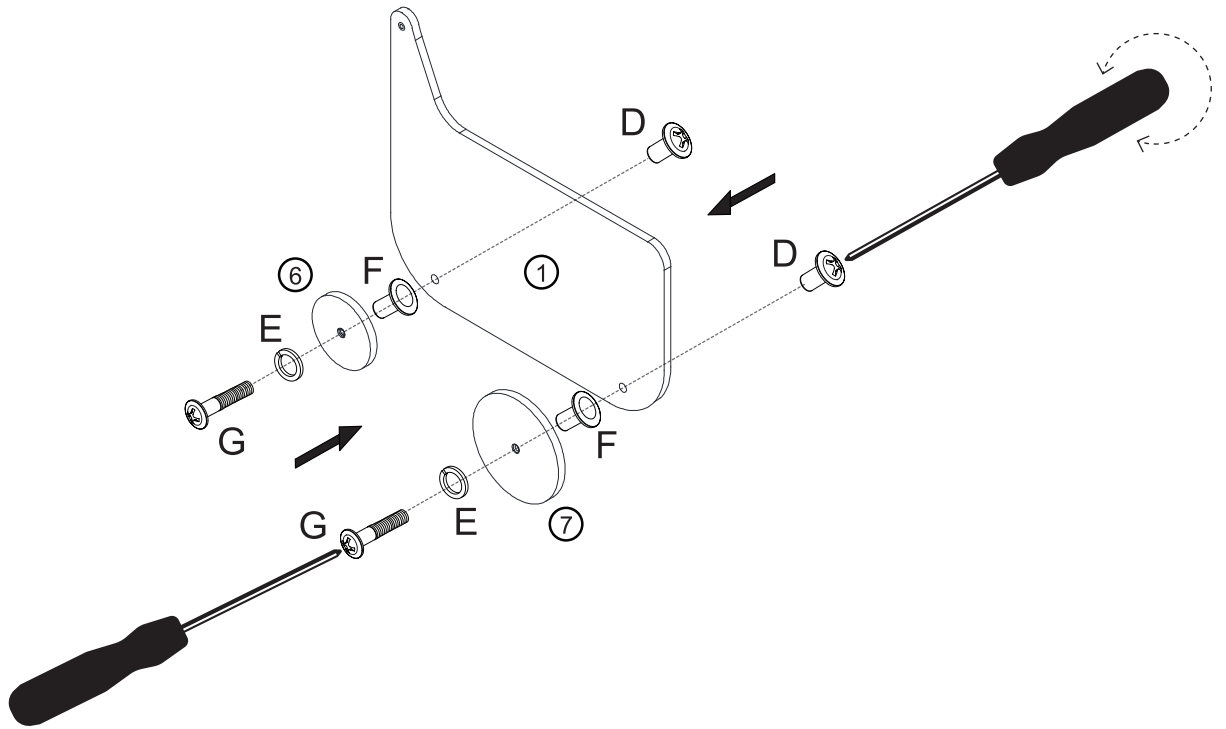

Insert Connector D in to Panel 1. Insert Connector F in to Wheels 6 and 7.
Insert Connector G through Split Washer E, through wheel and Connector F in to Connector D as shown above.

**NB: Using 2 x Phillips Screwdrivers hold Connector G tight as you turn Connector D.
Check wheels spin freely.**

Step 2

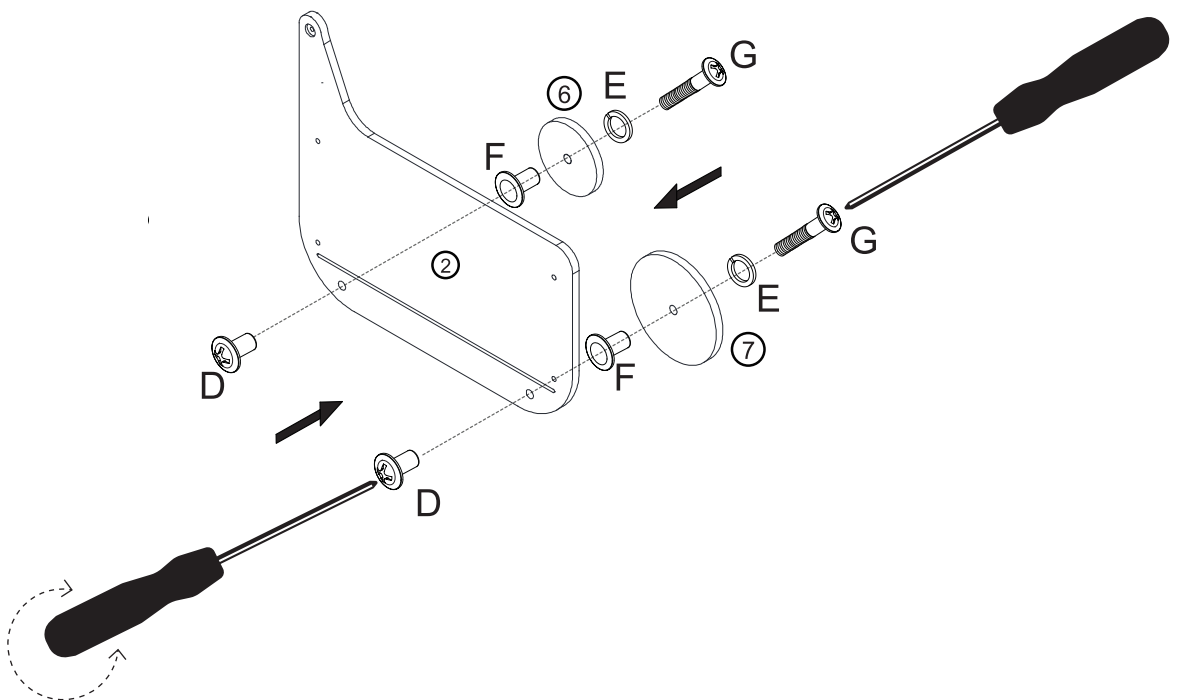

Insert Connector D in to Panel 2. Insert Connector F in to Wheels 6 and 7.
Insert Connector G through Split Washer E, through wheel and Connector F in to Connector D as shown above.

**NB: Using 2 x Phillips Screwdrivers hold Connector G tight as you turn Connector D.
Check wheels spin freely.**

Step 3

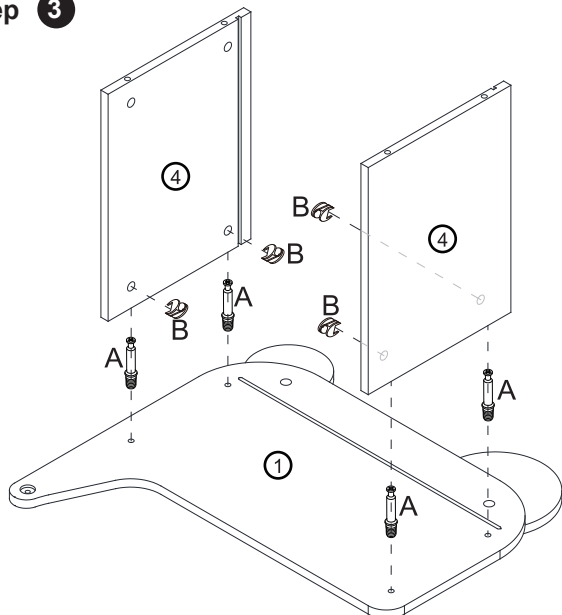

Insert Cam Lock B in to Panels 4.
Screw 4 x Cam Dowels A in to Panel 1.
Fit Panels 4 to Panel 1.
Turn Cam Locks.

Step 4

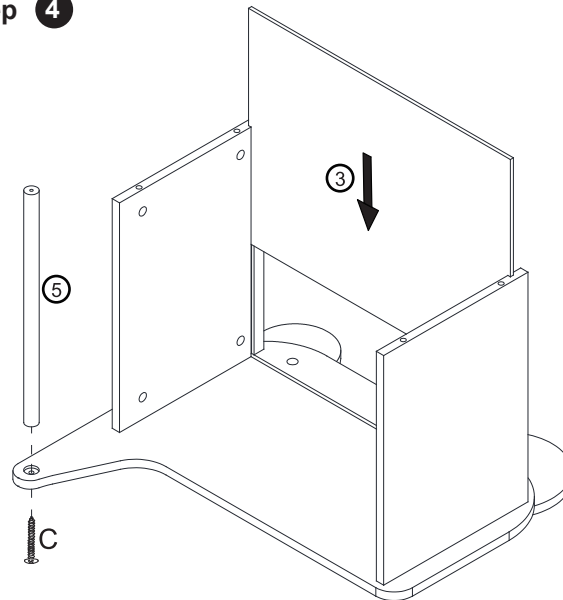

Use 1 x Screw C to secure Part 5.
Insert Bottom Panel 3 in to grooves.

Step 5

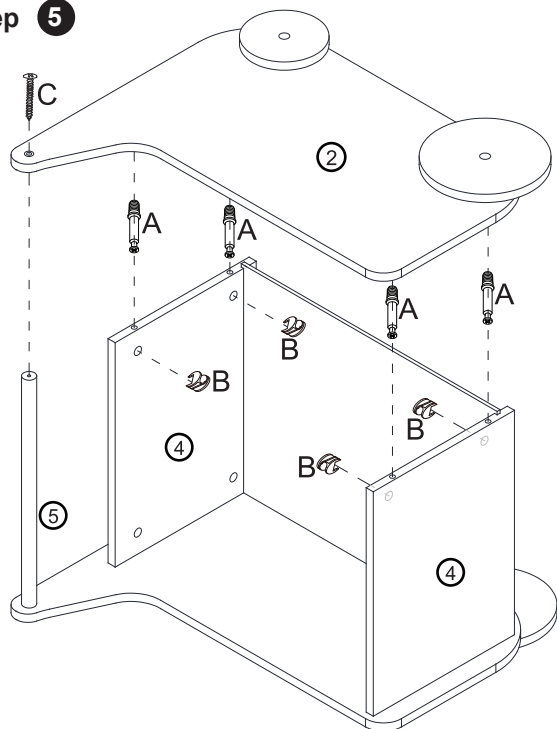

Insert Cam Lock B in to Panels 4.
Screw 4 x Cam Dowels A in to Panel 2.
Fit Panel 2 to Panels 4.
Turn Cam Locks.
Use 1 x Screw C to secure Part 5.

Step 6

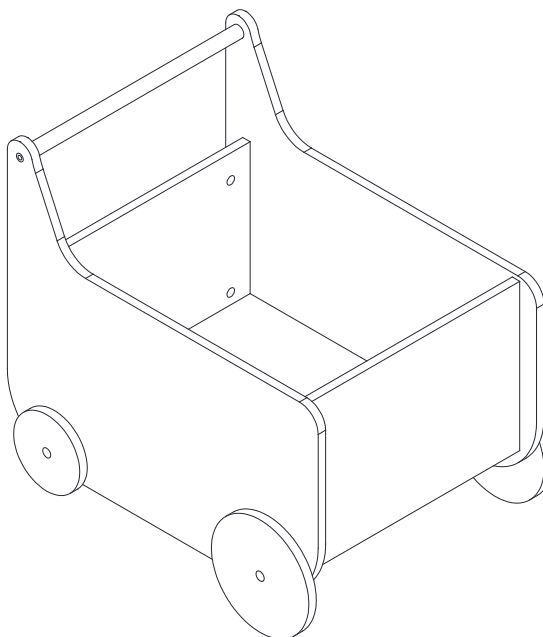

Assembly is now complete.



WARNING:
CHOKING HAZARD – Small parts.