

HARDWARE LIST

Ax1

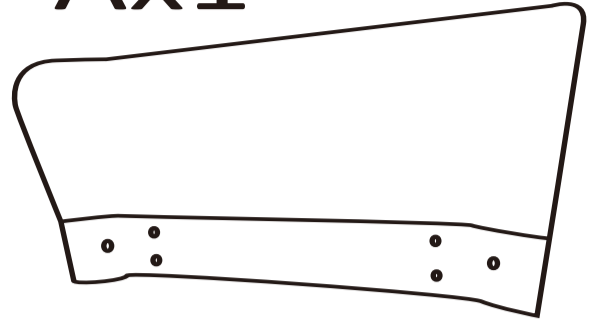

Bx1



Cx4

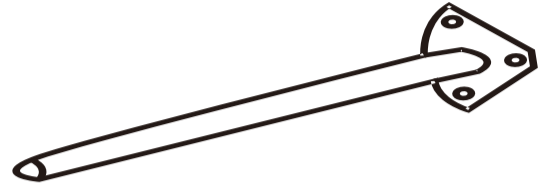

Dx6
M8x55mm

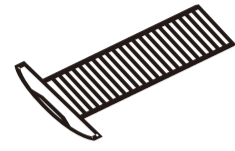

Ex12
M6x20mm



Fx6

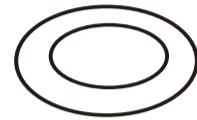

Gx6

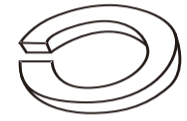

Hx1 M6



Be sure to check all packing material carefully for small parts, which may have come loose inside the carton during shipment.

ASSEMBLY INSTRUCTIONS

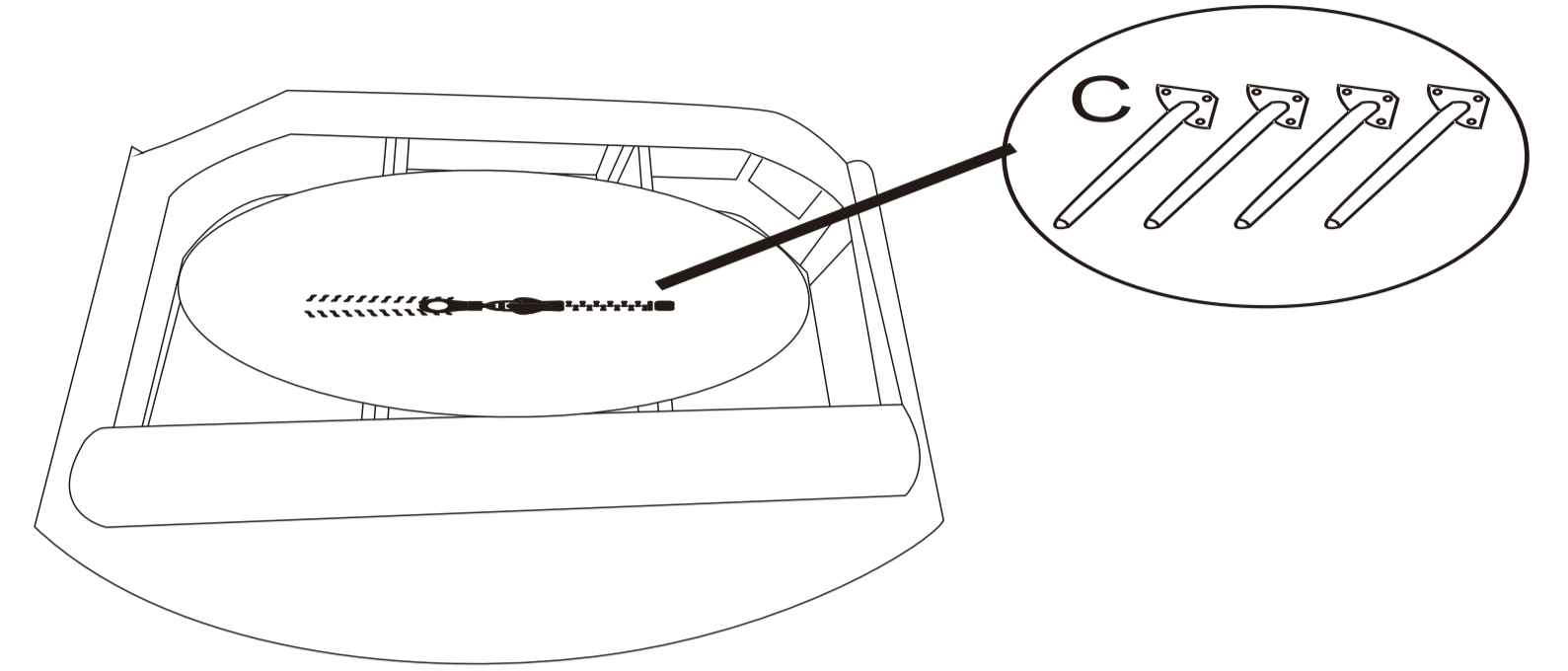

STEP 1: Place seat B on clean padded surface. Open the zipper pocket under seat and take legs C and hardware pack out.

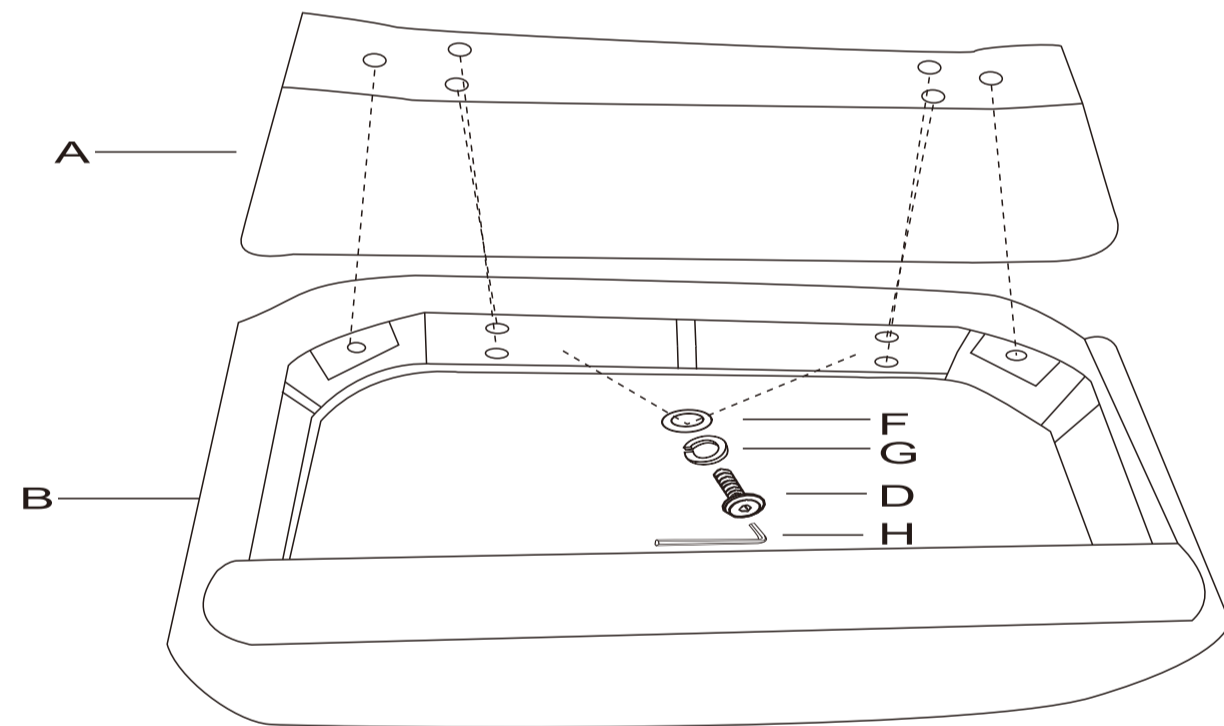

STEP 2: Align hole position on seat cushion B and back A, use bolt D, flat washer F, spring washer G, allen wrench H to connect seat and back, make sure bottom edge of back align with rear bottom edge of seat then fasten all bolts to secure.

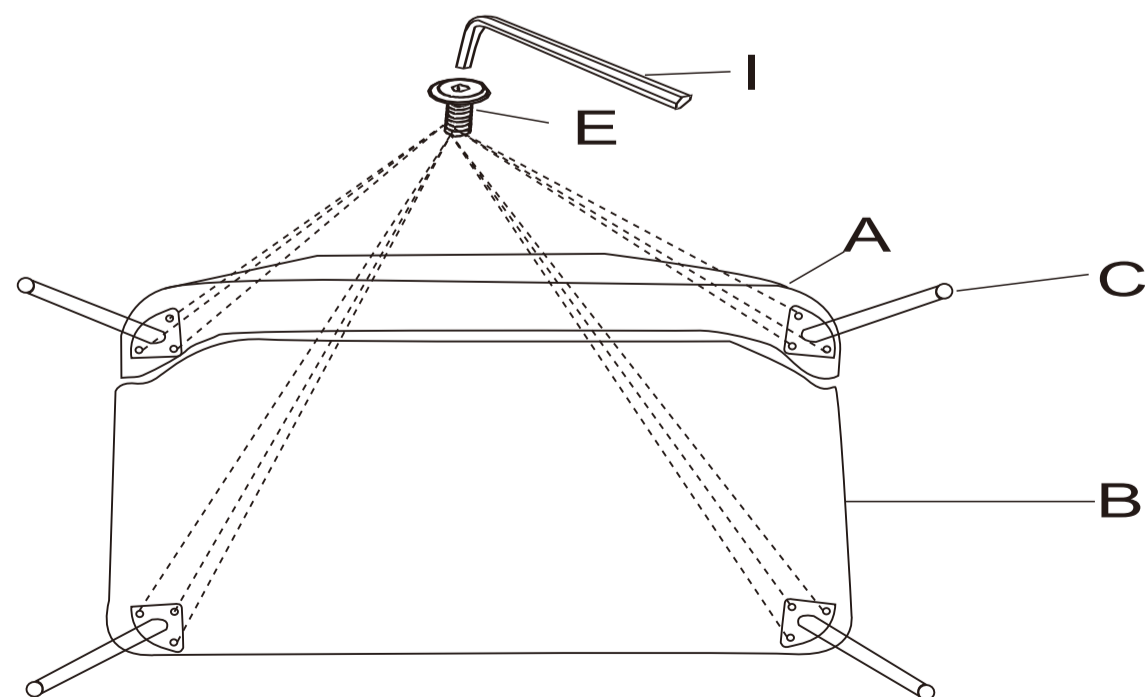

STEP 3 : Use bolt E , allen key I to attach legs C to bottom of the seat, fasten all bolts to secure.

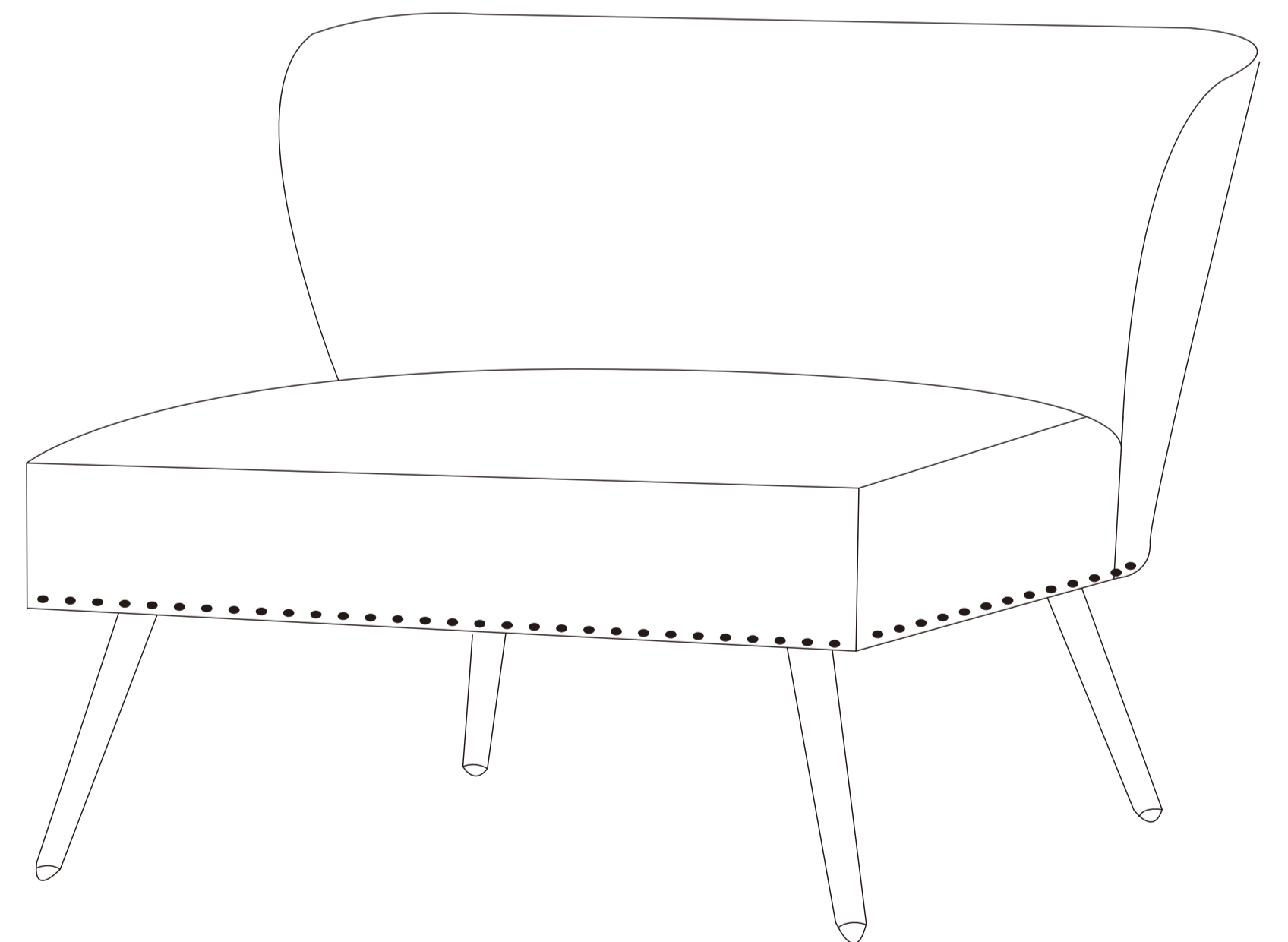

Adjust levelers under legs to set the seat level.

STEP 4 :Assembly completed.