

# ASSEMBLY INSTRUCTION

## Sofa Sectional Set

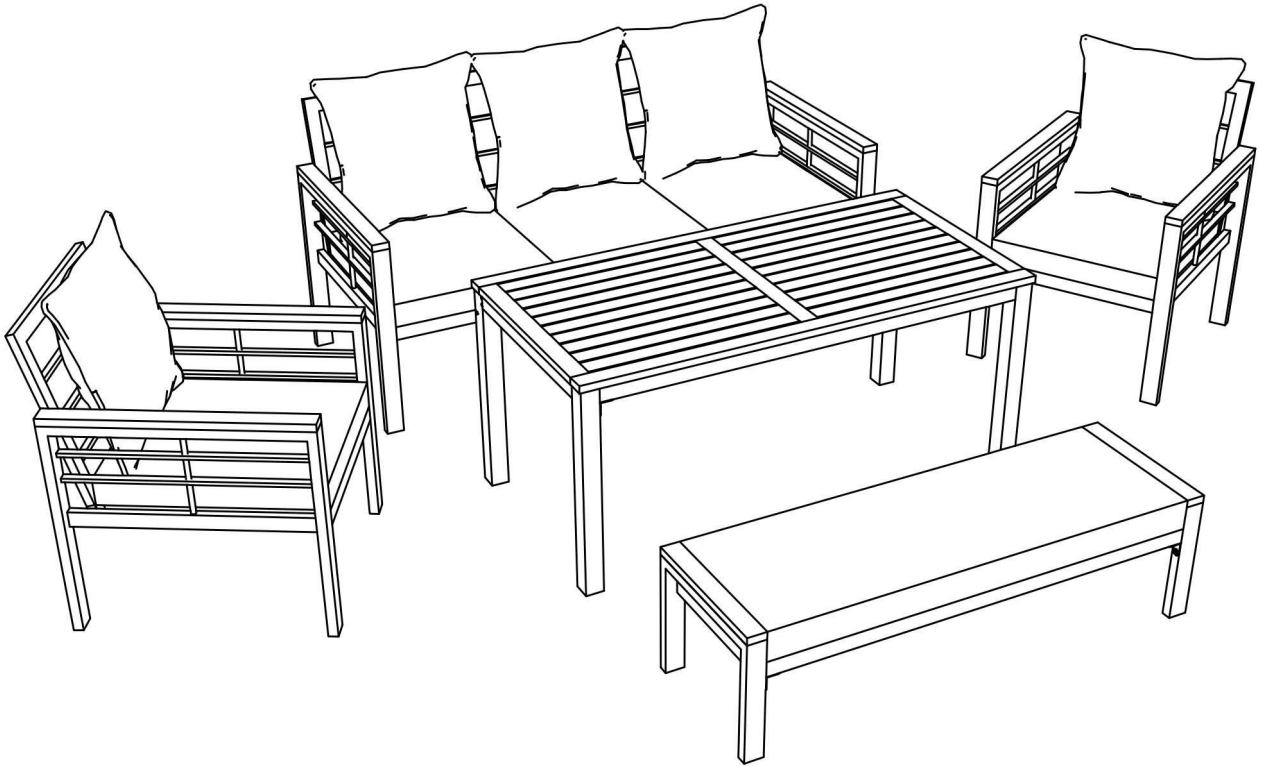

**Please read all instructions carefully:**

- 1. Have 2 adults on hand for assembly.**
- 2. 50% Tighten before fixing all screws, Allen wrench is recommended instead of an electric drill.**
- 3. Place the item on a flat ground to adjust and make sure it remains stable.**
- 4. Tighten up all screws with tools gradually.**
- 5. If the screws are not aligned with holes during assembly, please loosen all the other screws to 50% and continue the assembly process.**
- 6. If the item is not stable, please loosen all the screws, adjust it on a flat ground and tighten up all screws again.**
- 7. Note : If one or some screws are fully tightened during assembly, chances are the others will not be aligned with holes. In addition, all the holes are designed to be relatively larger to provide more space for the adjustment of the screws.**



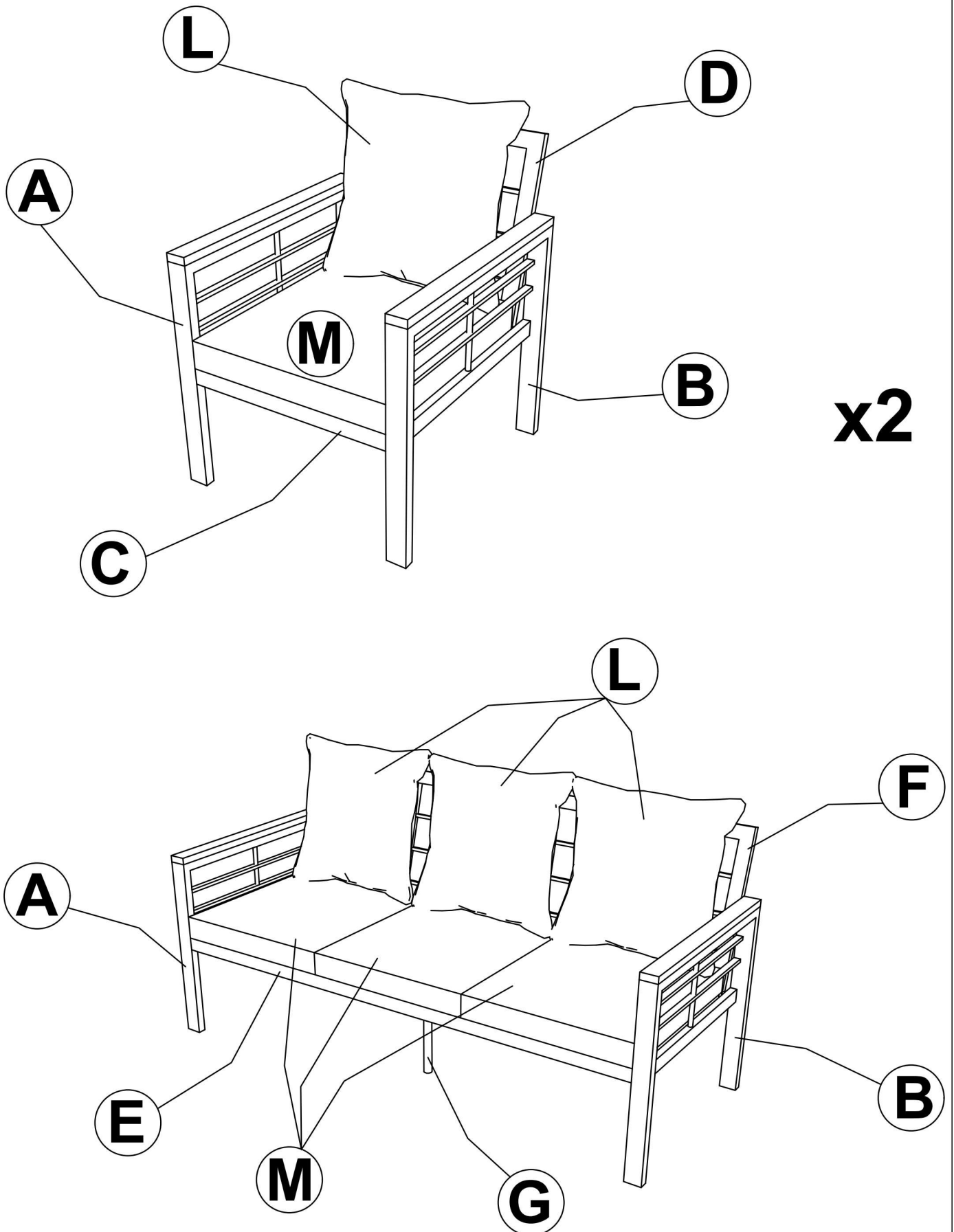

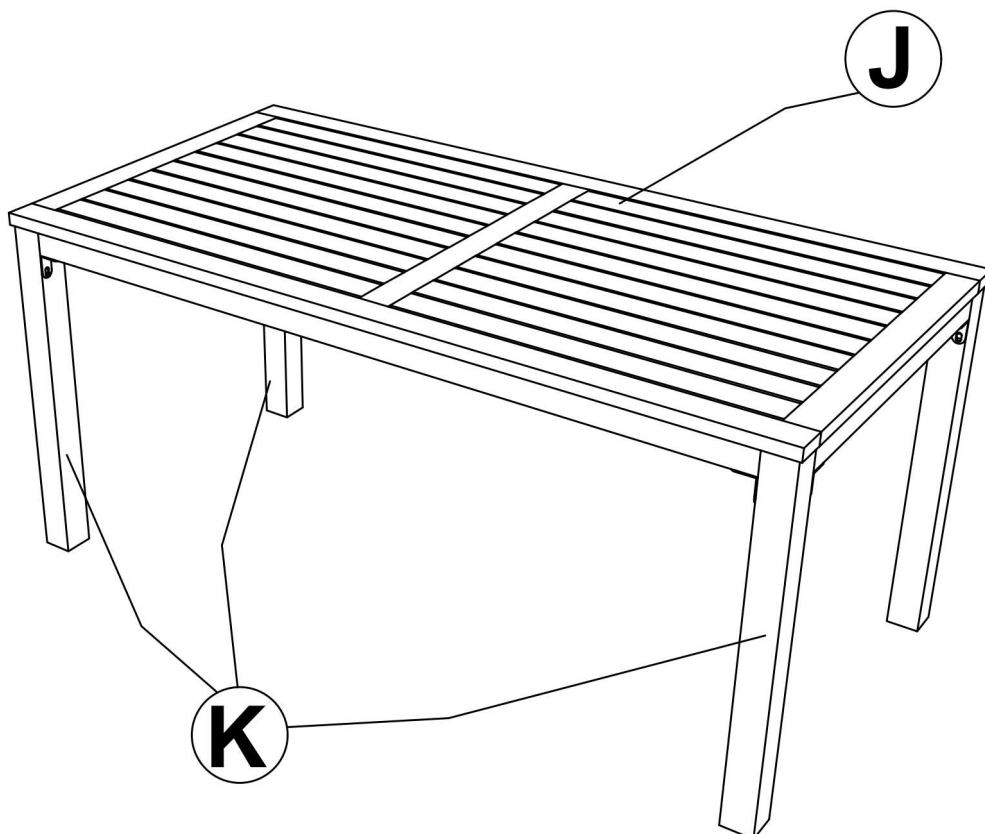
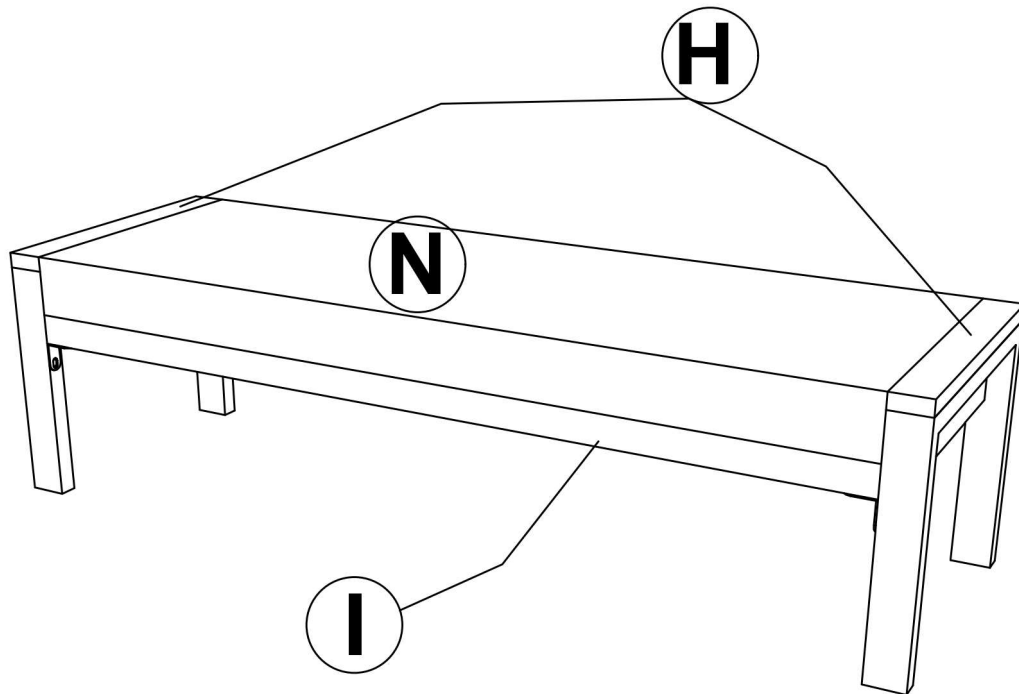

# Employed View



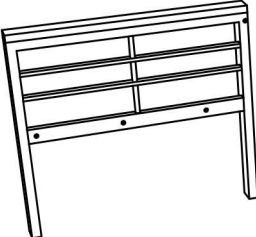

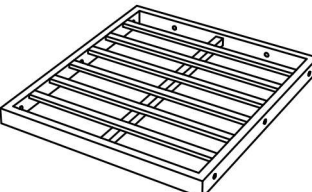
# Employed View

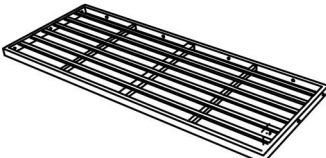
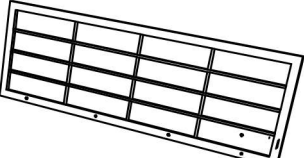

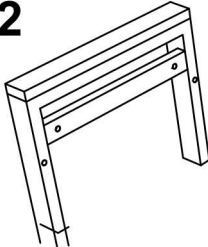
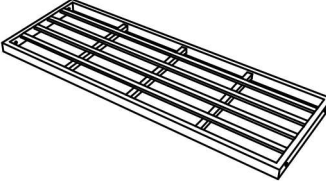
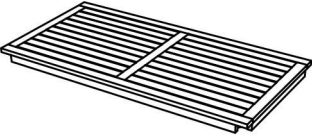
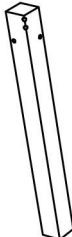
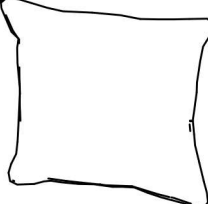
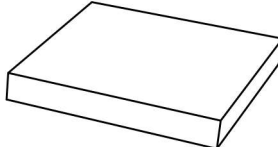
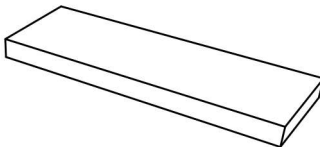
# PART LIST

<p><b>Ax3</b></p>  <p>Left armrest</p>	<p><b>Bx3</b></p>  <p>Right armrest</p>	<p><b>Cx2</b></p>  <p>Seat chair</p>	<p><b>Dx2</b></p>  <p>Back chair</p>
<p><b>Ex1</b></p>  <p>Seat bench</p>	<p><b>Fx1</b></p>  <p>Back bench</p>	<p><b>Gx1</b></p>  <p>Middle leg</p>	<p><b>Hx2</b></p>  <p>Leg stool</p>
<p><b>Ix1</b></p>  <p>Seat Stool</p>	<p><b>Jx1</b></p>  <p>Table top</p>	<p><b>Kx4</b></p>  <p>Table leg</p>	<p><b>Lx5</b></p>  <p>Pillow</p>
<p><b>Mx5</b></p>  <p>Seat cushion</p>	<p><b>Nx1</b></p>  <p>Cushion stool</p>		

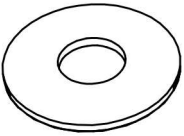
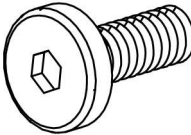
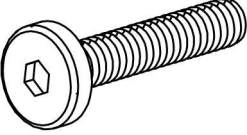
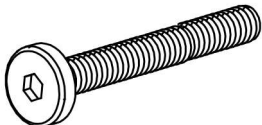
# HARDWARE LIST

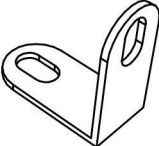
 <p><b>1-</b> Washer : 72 pcs Extra : 2 pcs</p>	 <p><b>2-</b> Bolt 6x15 : 28 pcs Extra : 2 pcs</p>	 <p><b>3-</b> Bolt 6x35 : 30 pcs Extra : 2 pcs</p>
 <p><b>4-</b> Bolt 6x55 : 14 pcs Extra : 2 pcs</p>	 <p><b>5-</b> Allen key : 2 pcs</p>	 <p><b>6-</b> Bracket : 12 pcs</p>

# CARTON CONTENT :

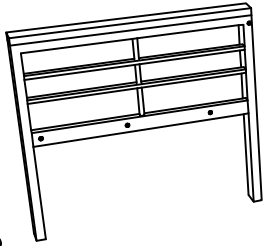

**Ax3** Left armrest

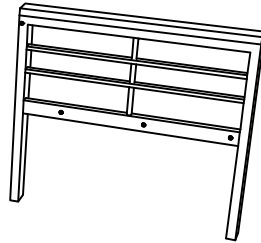

**Bx3** Right armrest

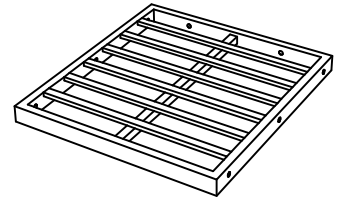

**Cx2** Seat chair

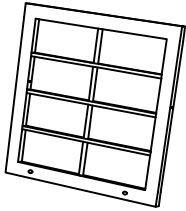

**Dx2** Back chair

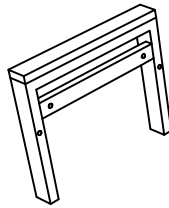

**Hx2** Leg stool



**Kx4** Table leg

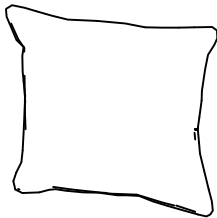

**Lx2** Pillow

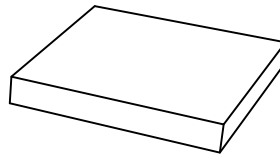

**Mx2** Seat cushion



Hardware

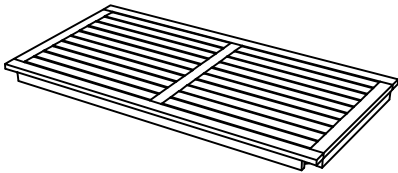

**Jx1** Table top

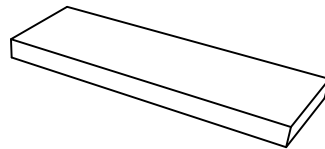

**Nx1** Cushion stool

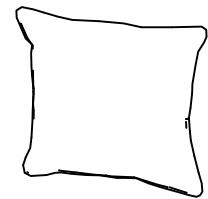

**Lx3** Pillow

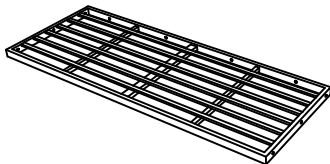

**Ex1** Seat bench

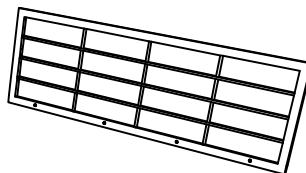

**Fx1** Back bench



**Gx1** Middle leg

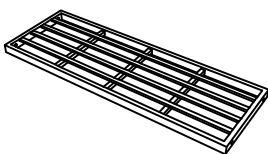

**Ix1** Seat stool

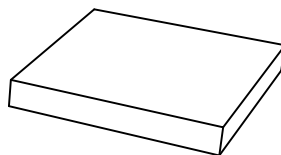

**Mx3** Seat cushion

# Step 1

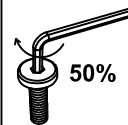

x2

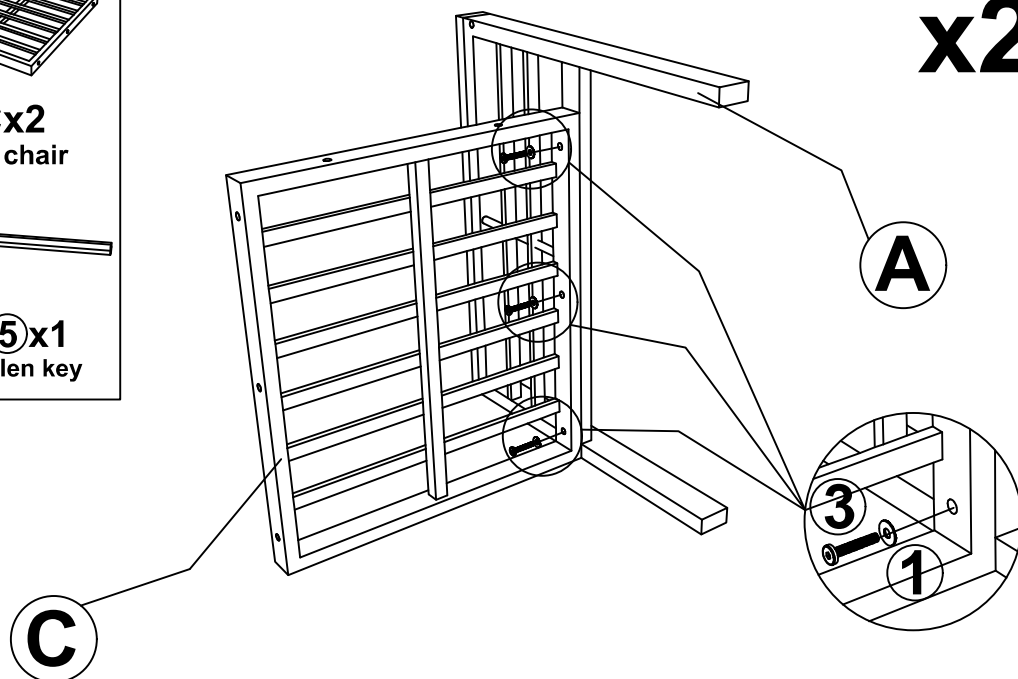
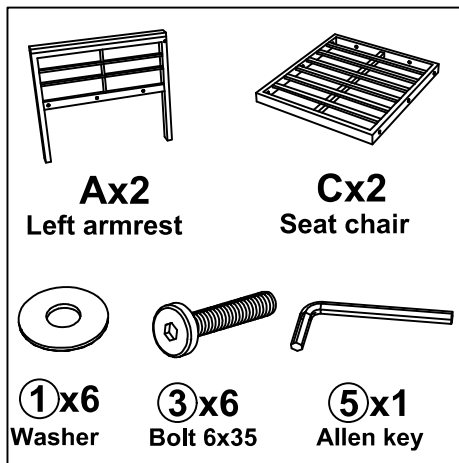

Connect the Left armrest (A) & Seat chair (C), tighten Bolt (3), Flat Washer (1) With Allen key (5)

# Step 2

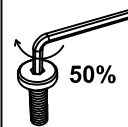

x2

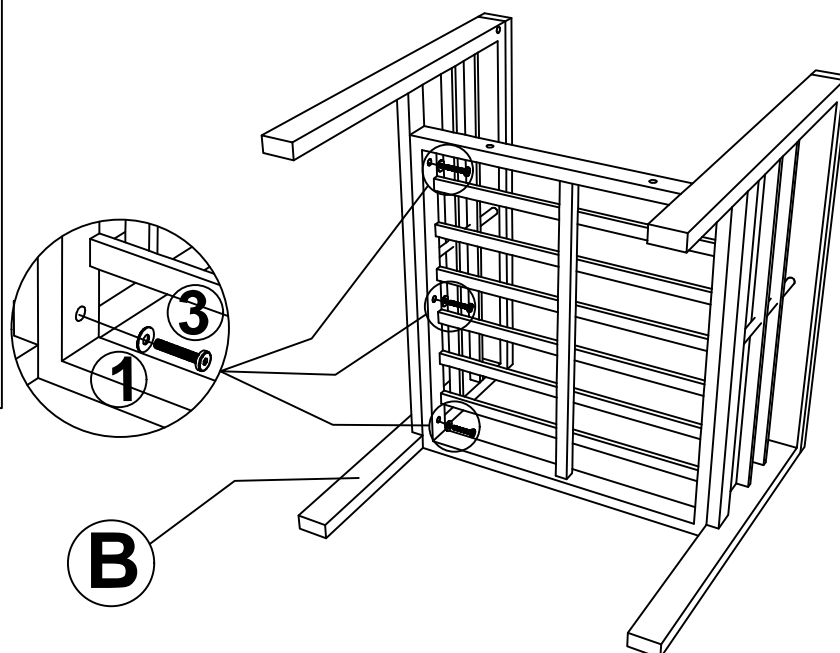
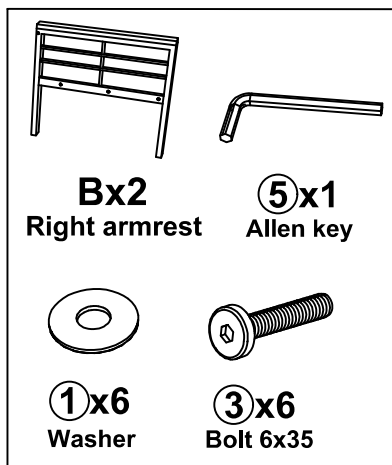

Connect The part from Step (1) & Right armrest (B), tighten Bolt (3), Flat Washer (1) With Allen key (5)

### Step 3

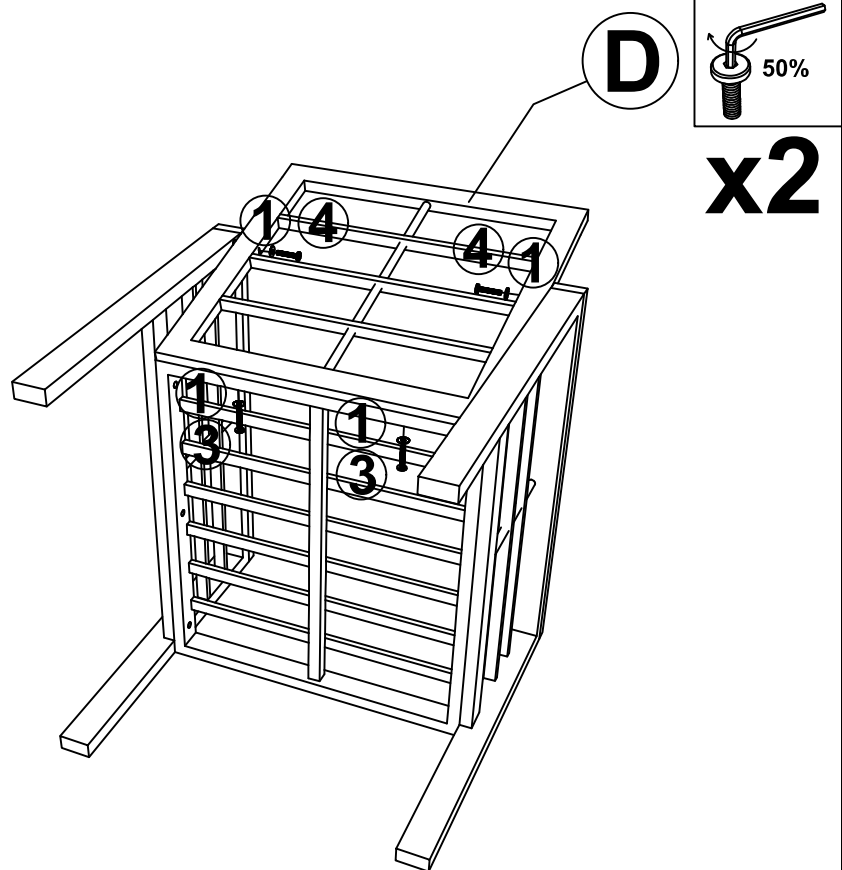
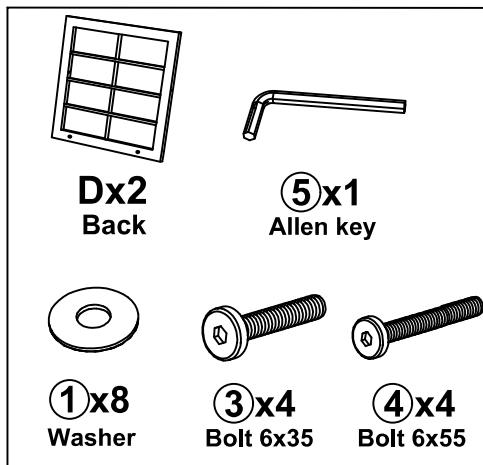

Connect The part from Step (2) & Back (D), tighten Bolt (3) & Bolt (4), Flat Washer (1) With Allen key (5)

### Step 4

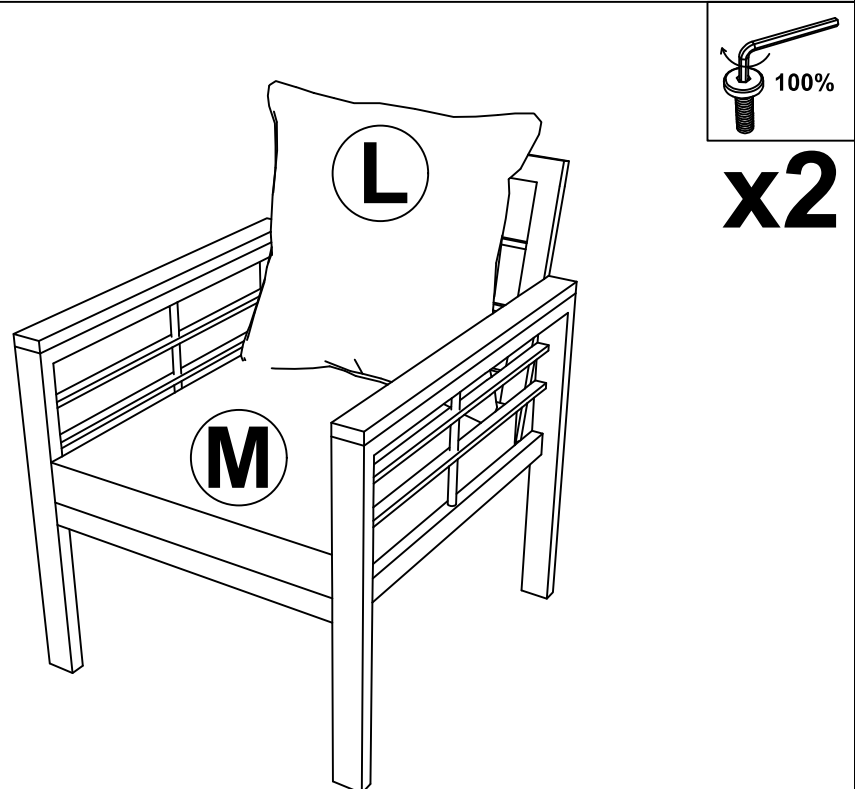
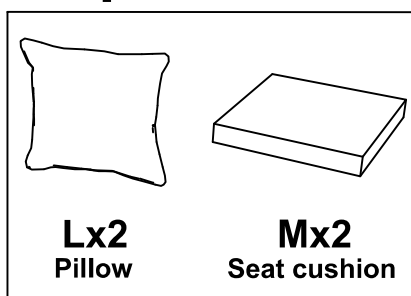

Put on Seat cushion (M), Pillow (L) to single chair to finish single chair

## Step 5

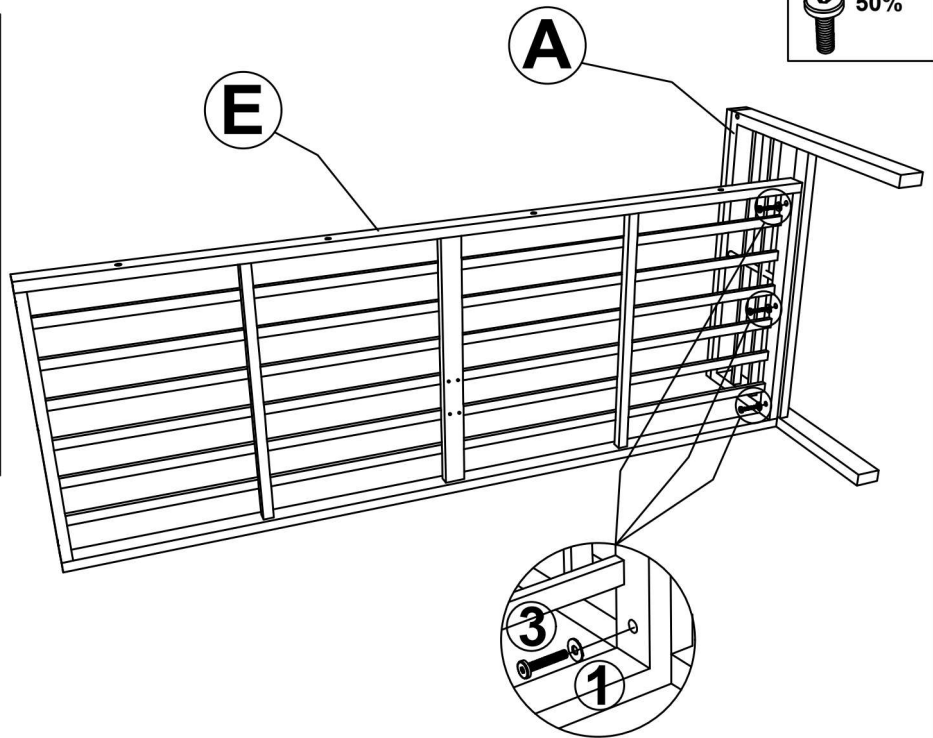
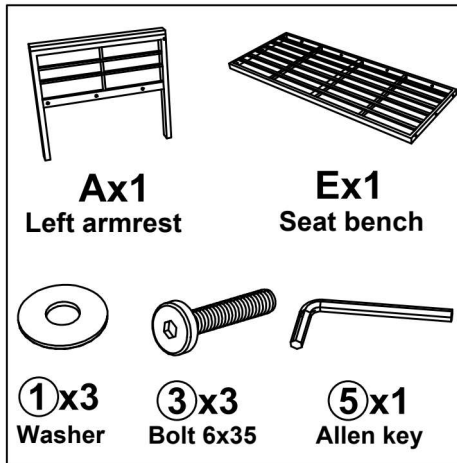

Connect the Left armrest (A) & Seat bench (E), tighten Bolt (3), Flat Washer (1) With Allen key (5)

## Step 6

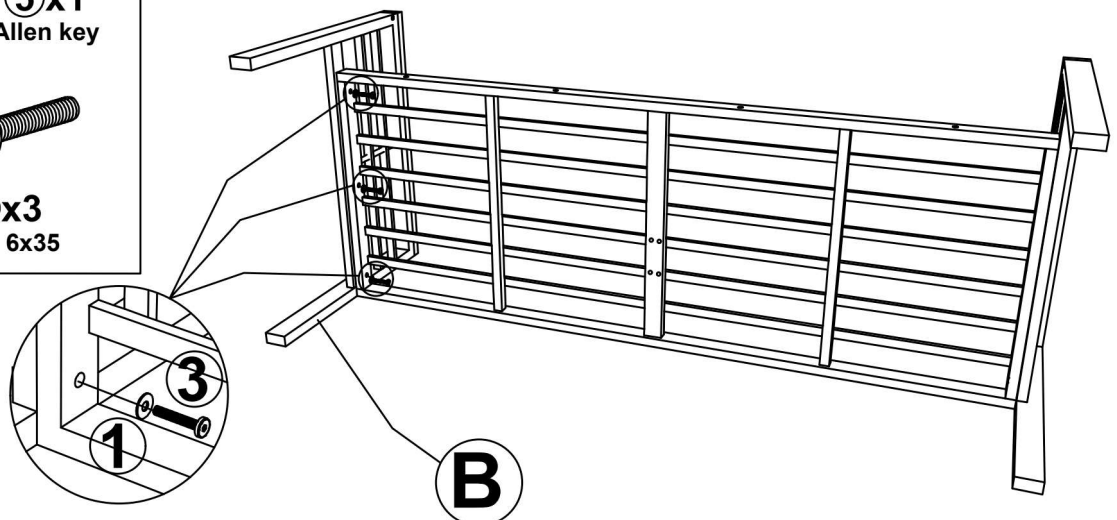
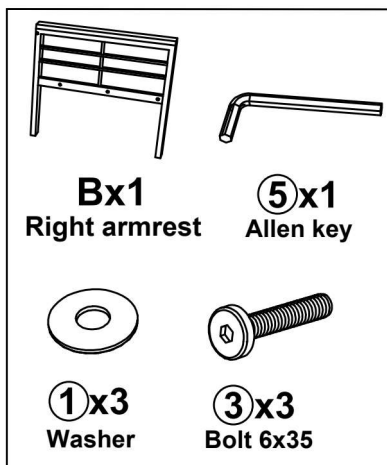

Connect The part from Step (5) & Right armrest (B), tighten Bolt (3), Flat Washer (1) With Allen key (5)

## Step 7

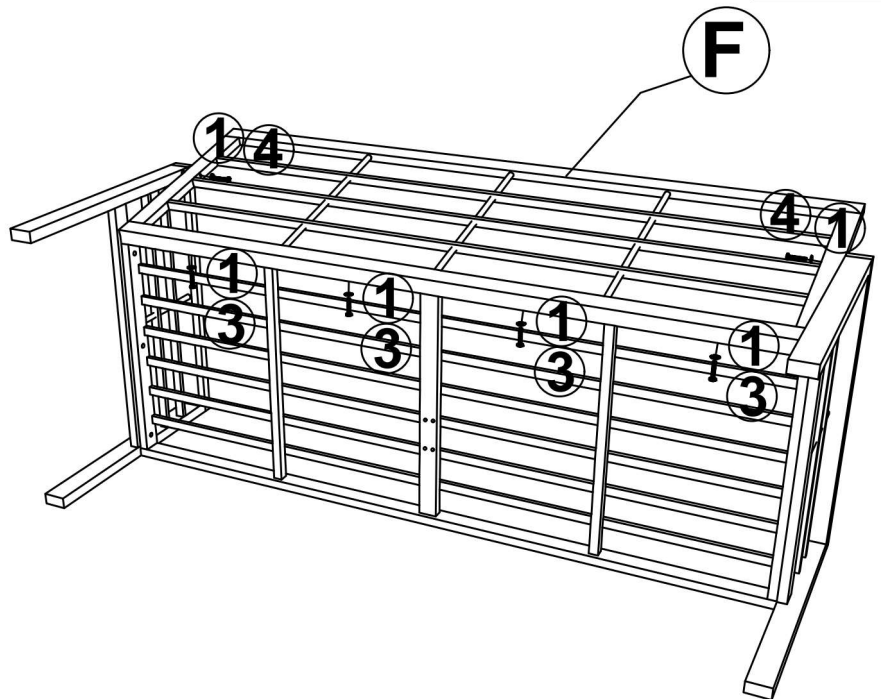
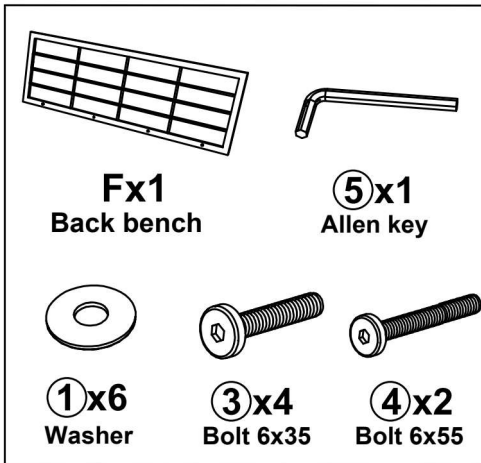

Connect The part from Step (6) & Back bench (F), tighten Bolt (3) & Bolt (4), Flat Washer (1) With Allen key (5)

## Step 8

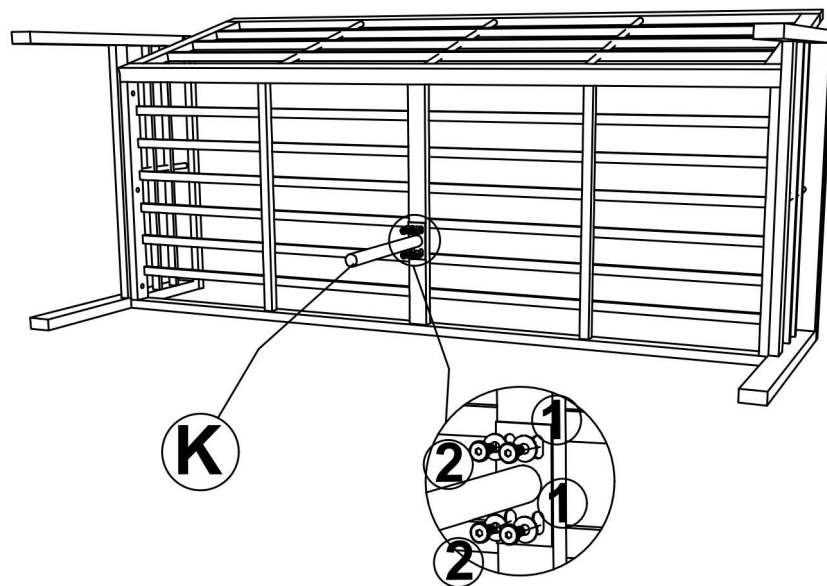
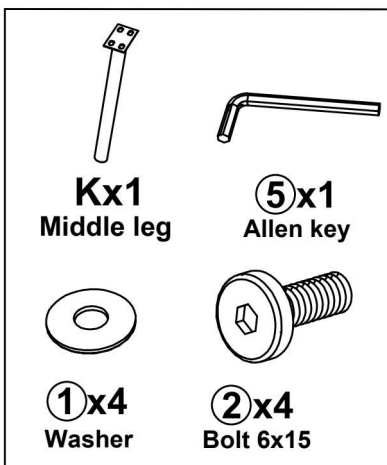

Connect The part from Step (7) & Middle leg (K), tighten Bolt (2), Flat Washer (1) With Allen key (5)

## Step 9

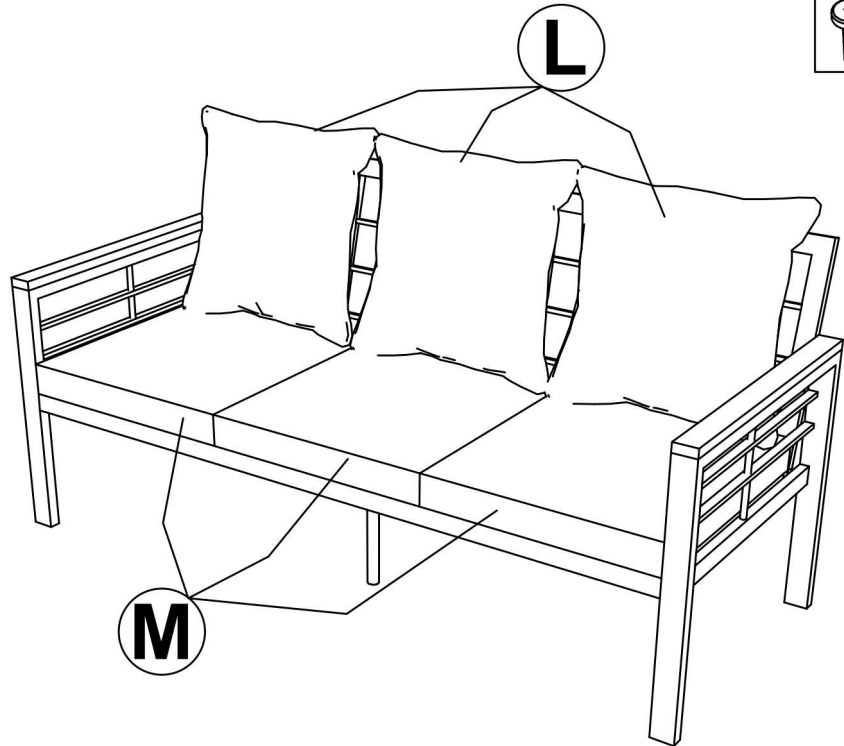
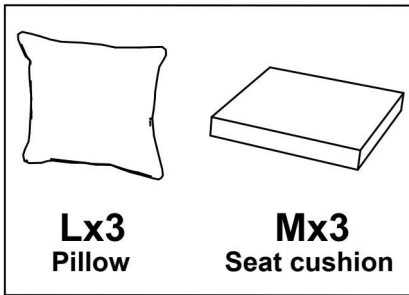

Put on Seat cushion (M), Pillow (L) to bench chair to finish bench chair

## Step 10

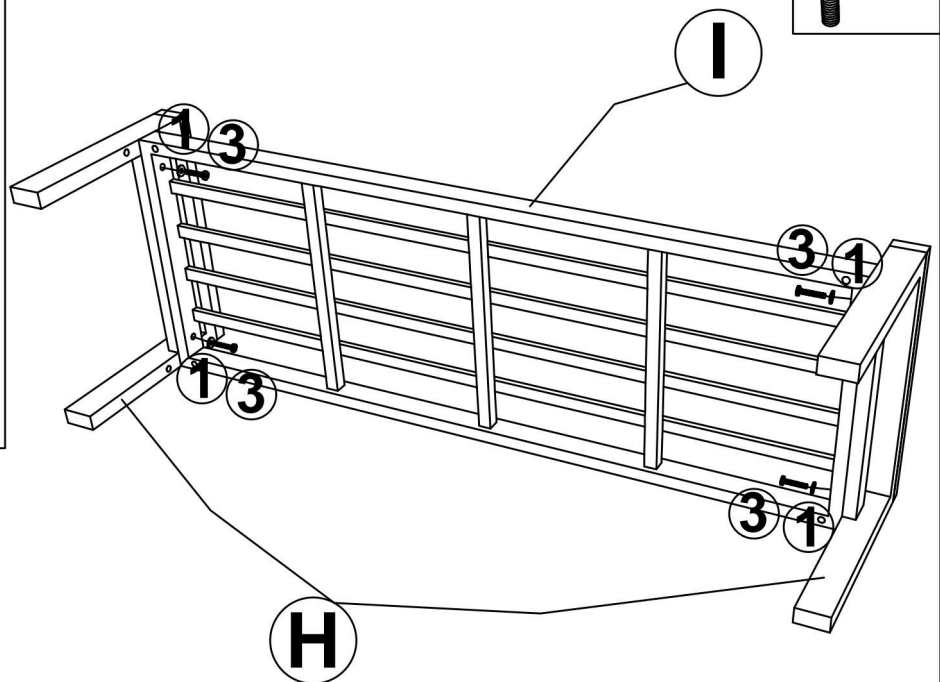
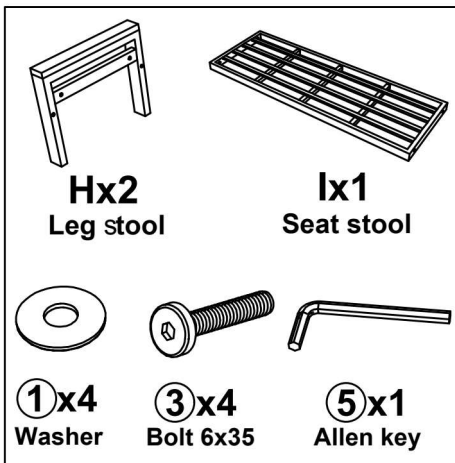

Connect the Leg stool (H) & Seat stool (I), tighten Bolt (3), Flat Washer (1) With Allen key (5)

## Step 11

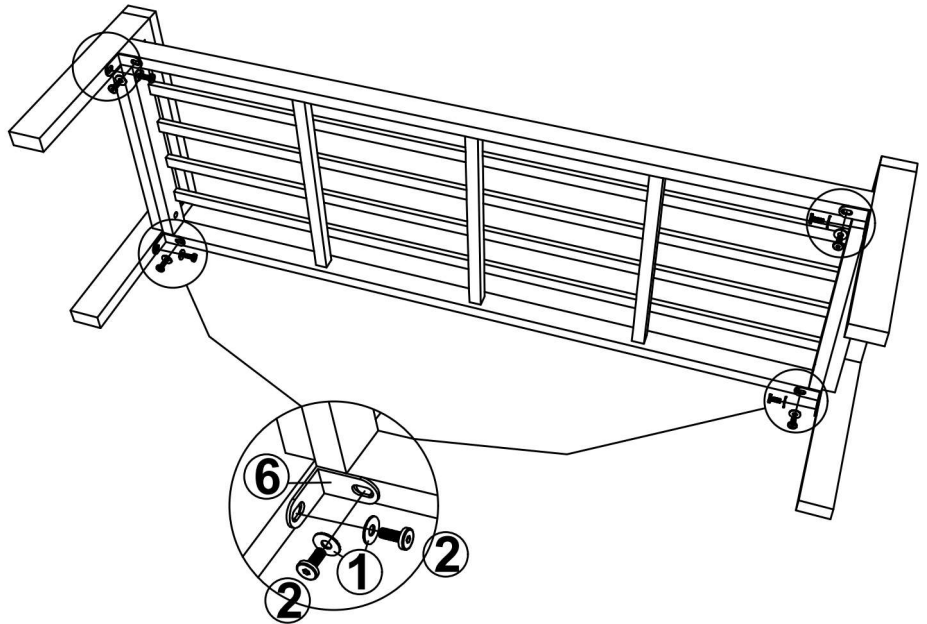
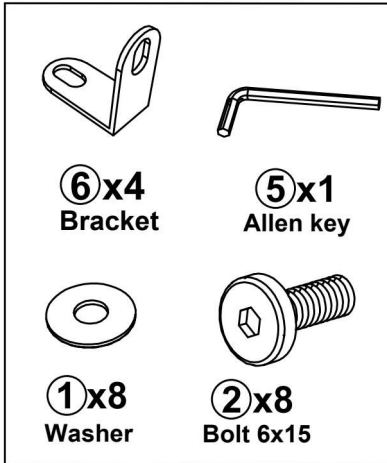

Connect The part from Step (10) & Bracket (6), tighten Bolt (2), Flat Washer (1) With Allen key (5)

## Step 12

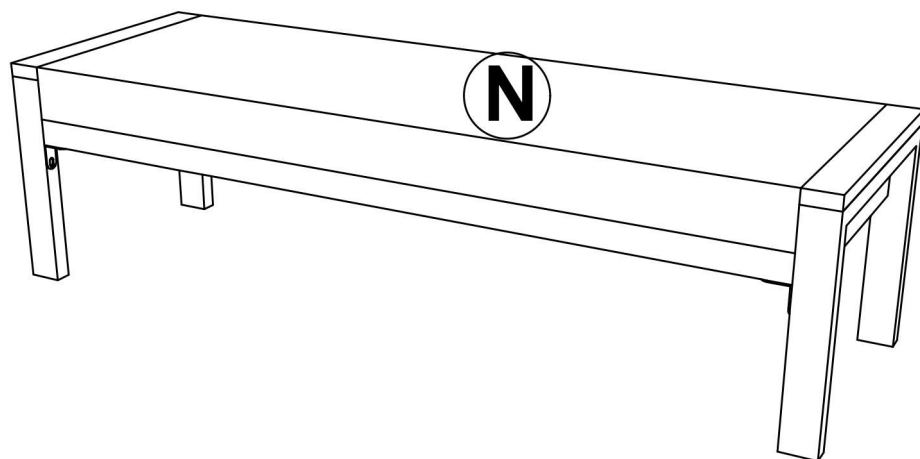
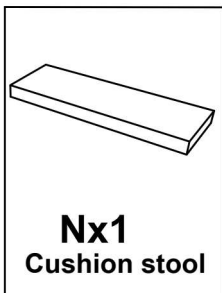

Put on Cushion stool (N) to finish stool

# Step 13

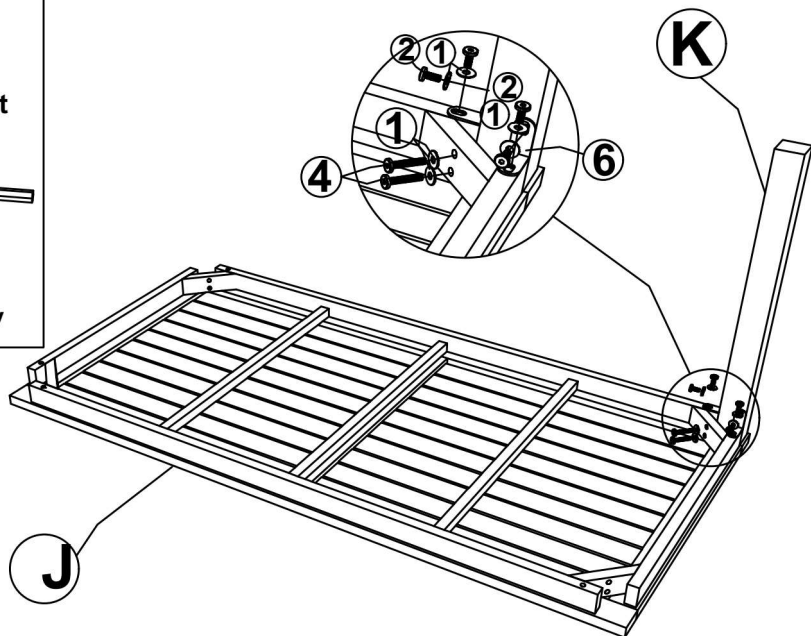
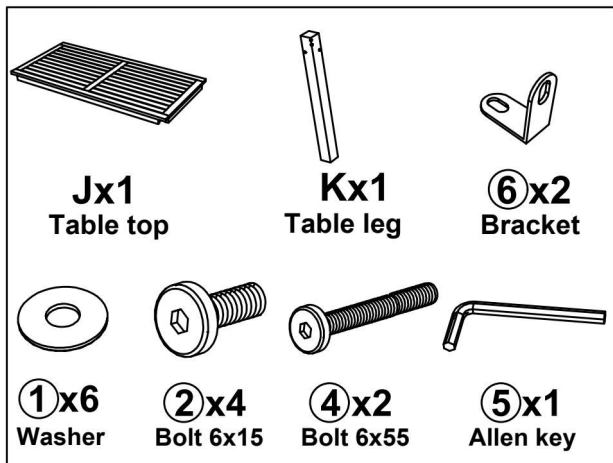
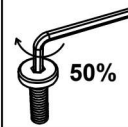

Connect the table top (J) & Table leg (K), Bracket (6), tighten Bolt (2), tighten Bolt (4), Flat Washer (1) With Allen key (5)

# Step 14

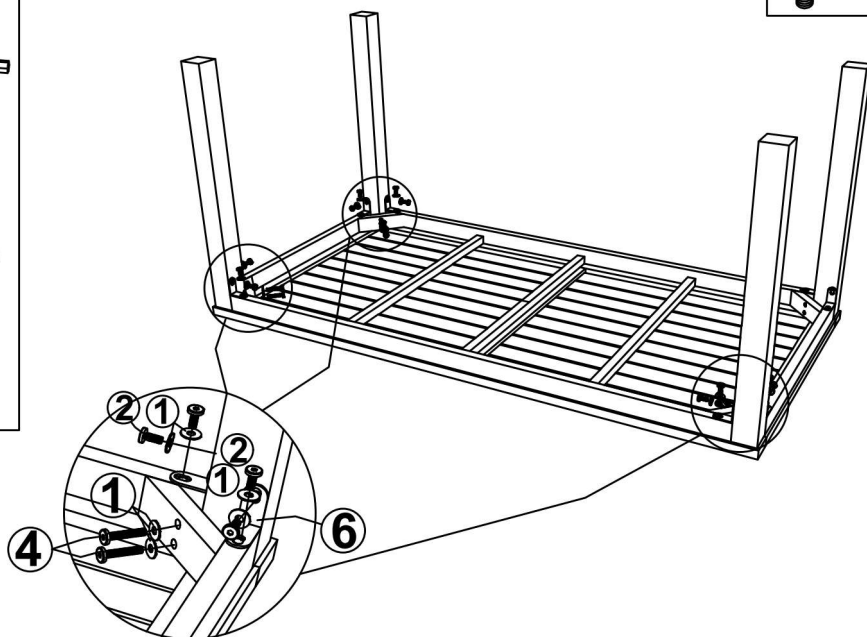
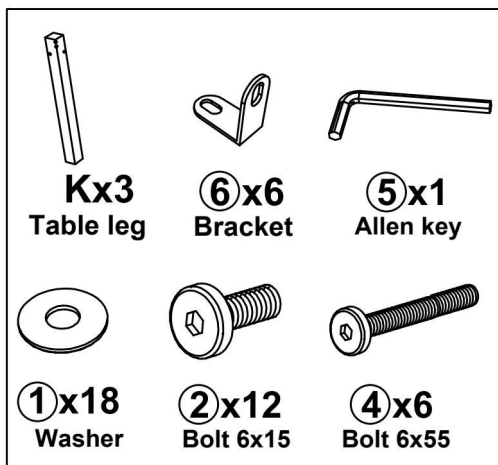
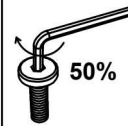

Connect the Table top (J) & Table leg (K), Bracket (6), tighten Bolt (2), tighten Bolt (4), Flat Washer (1) With Allen key (5)

# Step 15

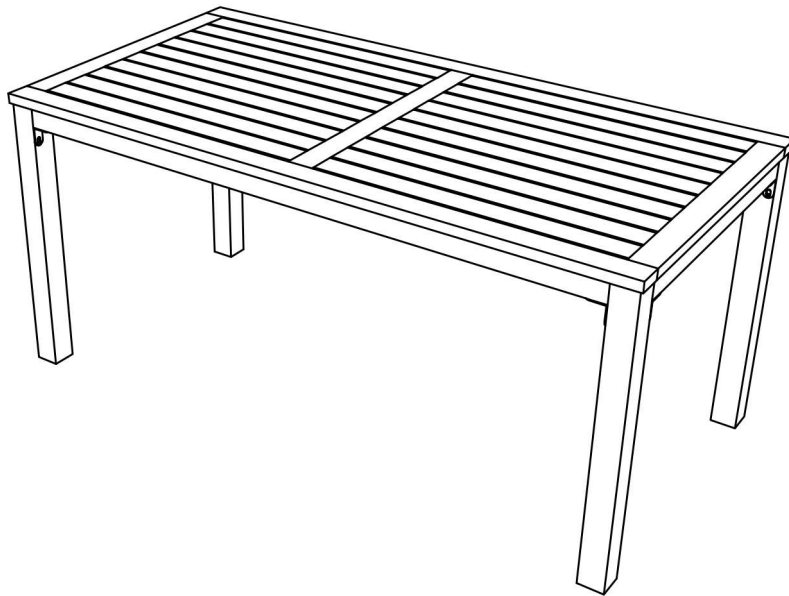

**Finish table**

# Step 16

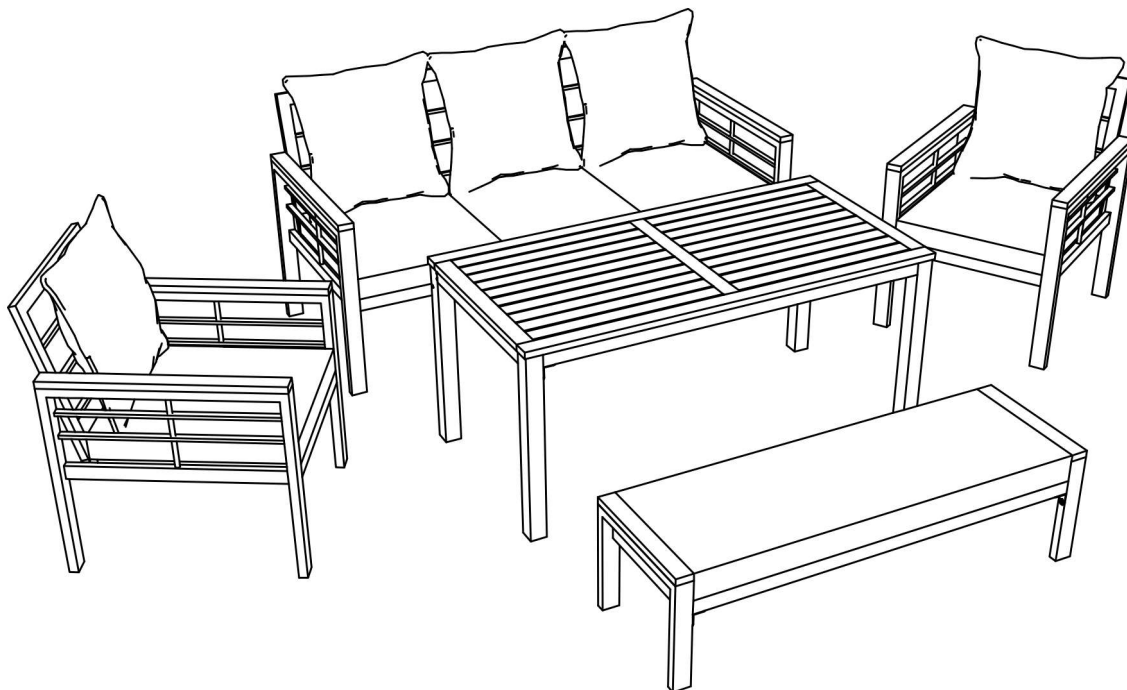

**Finish**