

# ASSEMBLY INSTRUCTIONS

A1



x1

A2



x1

B



x1

C

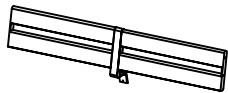

x1

D



x1

1/4

E



x6

1/4\*35

F



x9

1/4

G



x9

1/4

H



x4

1/4\*70

I



x3

1/4\*20

J



x1



Lock the screws into 3/4 parts according to the instructions, after levelling the product, tighten all the screws at the end

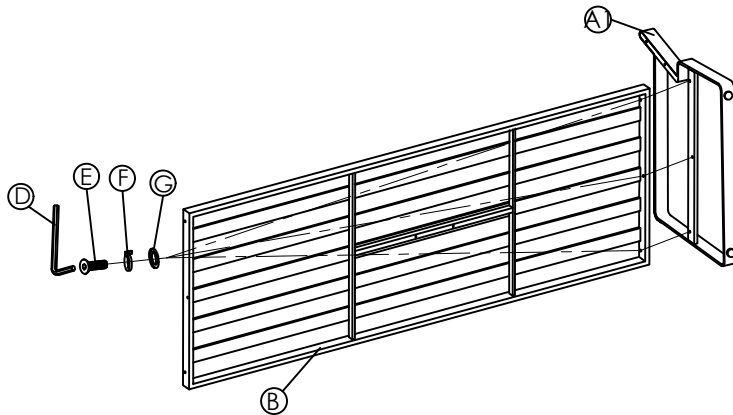

①

②

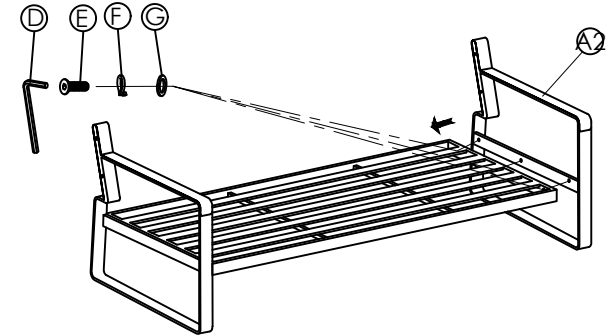

③

④

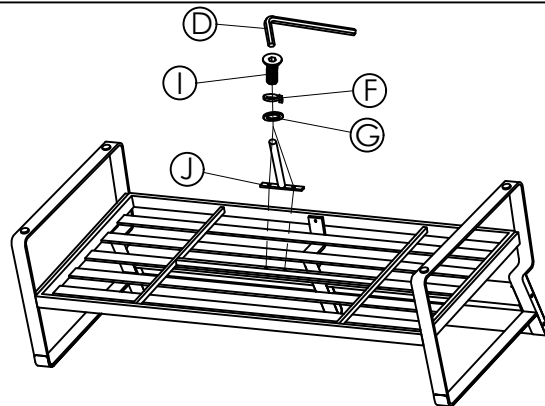
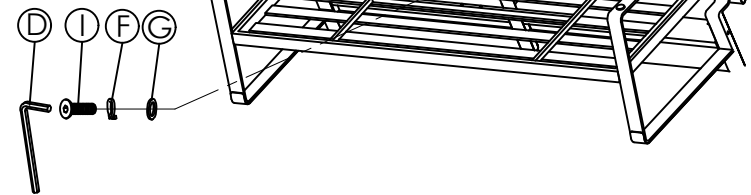
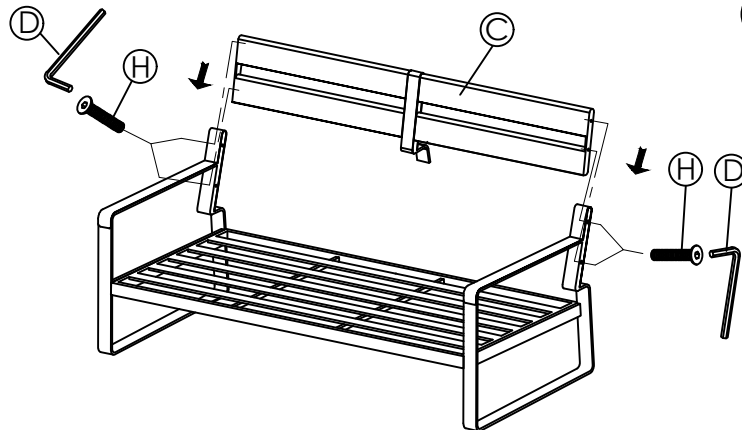

⑤

⑥

