

ASSEMBLY INSTRUCTION

Thank you for purchasing this quality product. Be sure to check all packing material carefully for small parts which may have come loose inside the carton during shipment. Separate, identify and count all parts and hardware. Compare with the parts list to be sure all parts are present.

IMPORTANT : PLEASE READ INSTRUCTION BEFORE STARTING THE ASSEMBLY.

"DO NOT TIGHTEN SCREWS UNTIL COMPLETELY ASSEMBLED"

"DO NOT OVERTIGHT ANY HARDWARE"

WARNING : SMALL PARTS AND HARDWARE NOT FOR CHILDREN UNDER 3 YEARS. ADULT ASSEMBLY REQUIRED.

TABLE OF CONTENTS

HARDWARES LIST	PAGE 2
PARTS LIST	PAGE 3 - 4
PARTS' LOCATION	PAGE 5
ASSEMBLY STEPS	PAGE 6 - 12
ASSEMBLY COMPLETED	PAGE 12

ASSEMBLY TOOLS REQUIRED

1. Screwdriver (not provide)



2. Hammer (not provide)









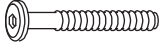

Skip the power drill this time.

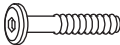



ASSEMBLY INSTRUCTION

HARDWARES LIST

ITEM	DESCRIPTION	DRAWING	QTY
A	JCBC SCREW M8 x 35MM		4 PCS
B	JCBC SCREW M6 x 15MM		20 PCS
C	JCBC SCREW M6 x 35MM		4 PCS
D	SPRING WASHER M6 x 12MM		4 PCS
E	FLAT WASHER M6 x 19MM		4 PCS
F	SPRING WASHER M8 x 13MM		4 PCS
G	FLAT WASHER M8 x 22MM		4 PCS
H	M4 ALLEN KEY (100MM)		1 PC
I	M5 ALLEN KEY (65MM)		1 PC
J	SUPPORT LEG ADJUSTABLE FEET		4 PCS

ASSEMBLY INSTRUCTION

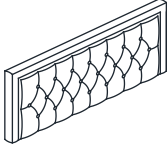
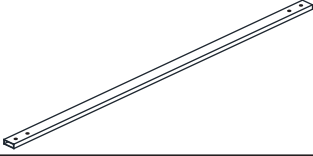
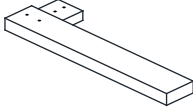
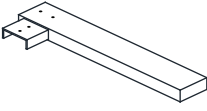
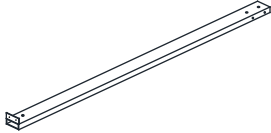
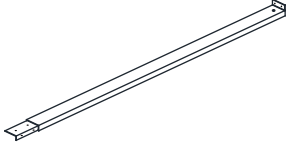
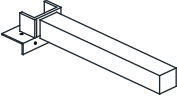
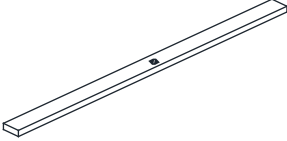

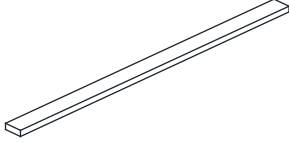
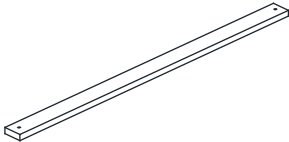

PARTS LIST

ITEM	DESCRIPTION	DRAWING	QTY
1	HEADBOARD		1 PC
2	FOOTBOARD METAL TUBE		1 PC
3	FOOTBOARD LEG (L)		1 PC
4	FOOTBOARD LEG (R)		1 PC
5	SIDE RAIL		2 PCS
6	SIDE RAIL		2 PCS
7	SIDE RAIL LEG		2 PCS
8	SLAT WITH NUT		4 PCS
9	SUPPORT LEG WITH HANGER BOLT		4 PCS
10	SLAT		8 PCS
11	CENTER SUPPORT		2 PCS

MORE PARTS DETAIL IN NEXT PAGE...

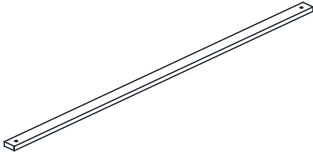
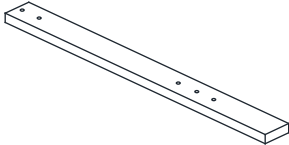
ASSEMBLY INSTRUCTION

PARTS LIST

ITEM	DESCRIPTION	DRAWING	QTY
12	SOCKET		24 PCS
13	SUPPORT RAIL		2 PCS
14	HEADBOARD LEG		2 PCS
15	SIDE RAIL COVER		2 PCS
16	FOOTBOARD COVER		1 PC
17	PLUG		1 PC
24	VELCRO TAPE		1 PC

ASSEMBLY INSTRUCTION

PARTS ' LOCATION

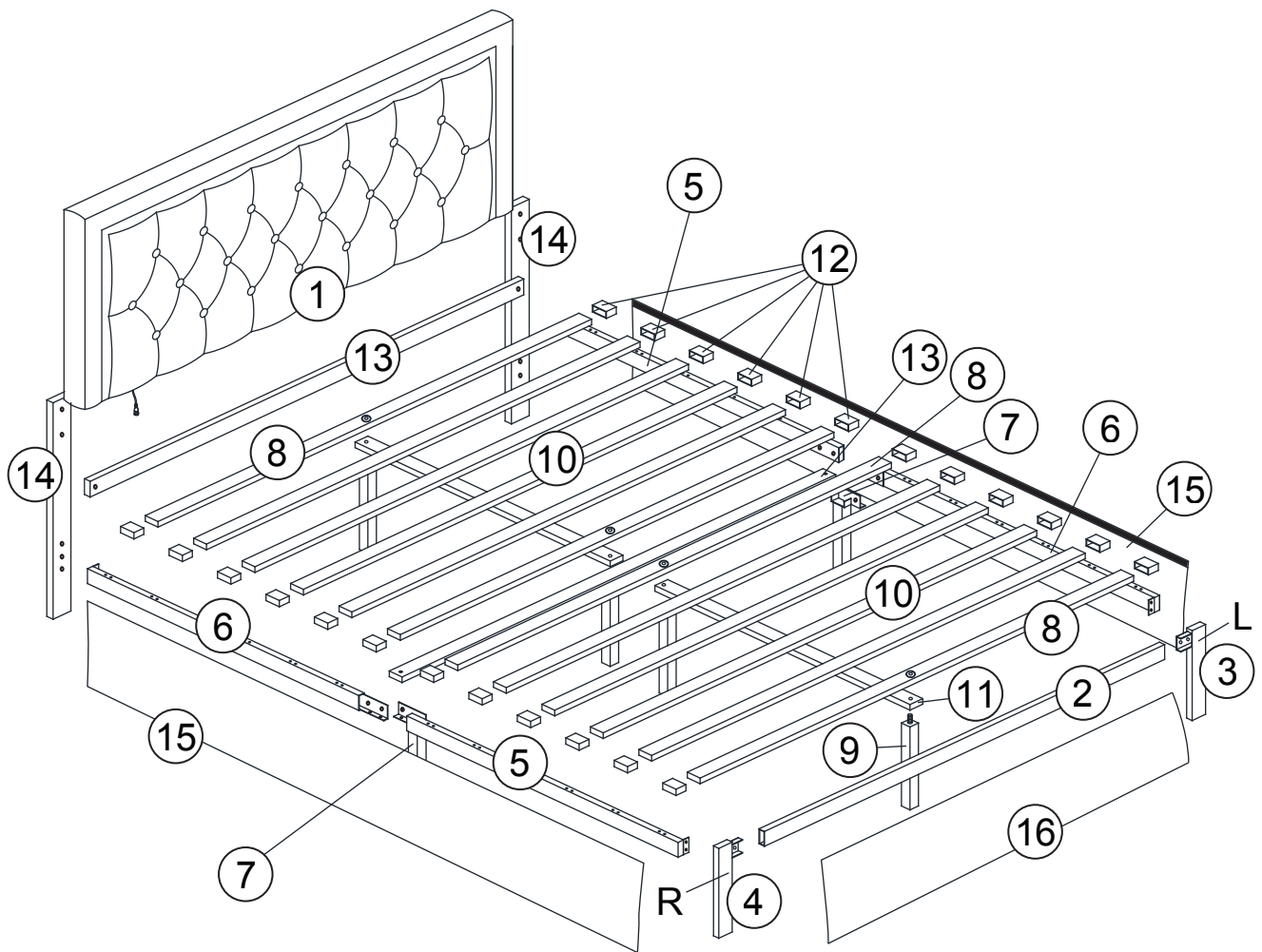

ASSEMBLY INSTRUCTION

STEP 1

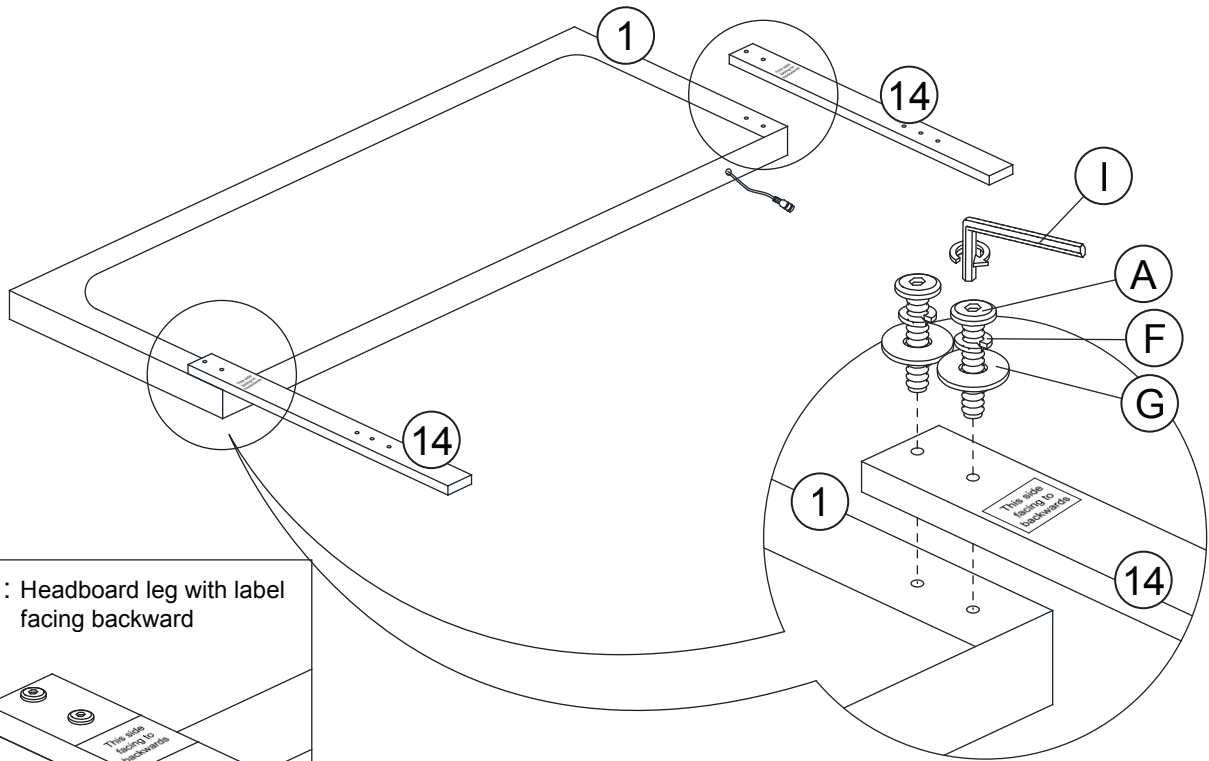

REMARK : Headboard leg with label facing backward

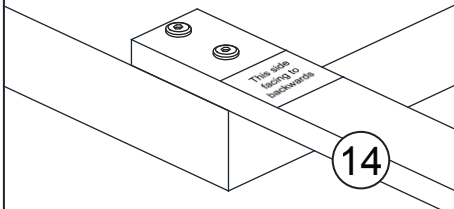

STEP 2

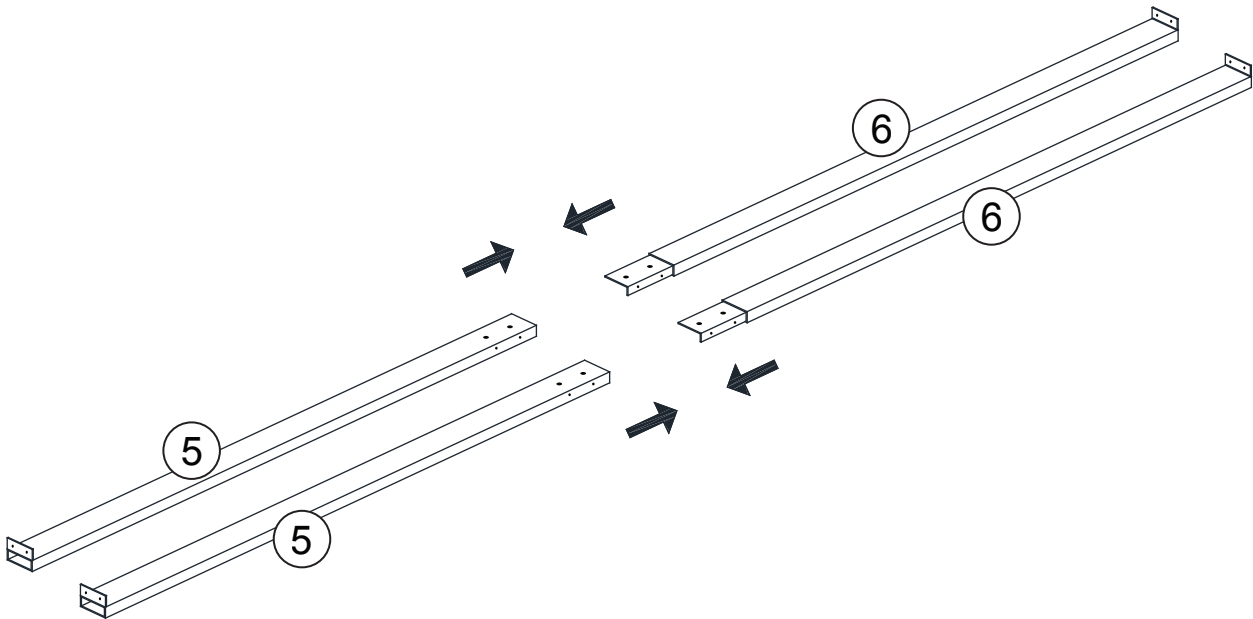

ASSEMBLY INSTRUCTION

STEP 3

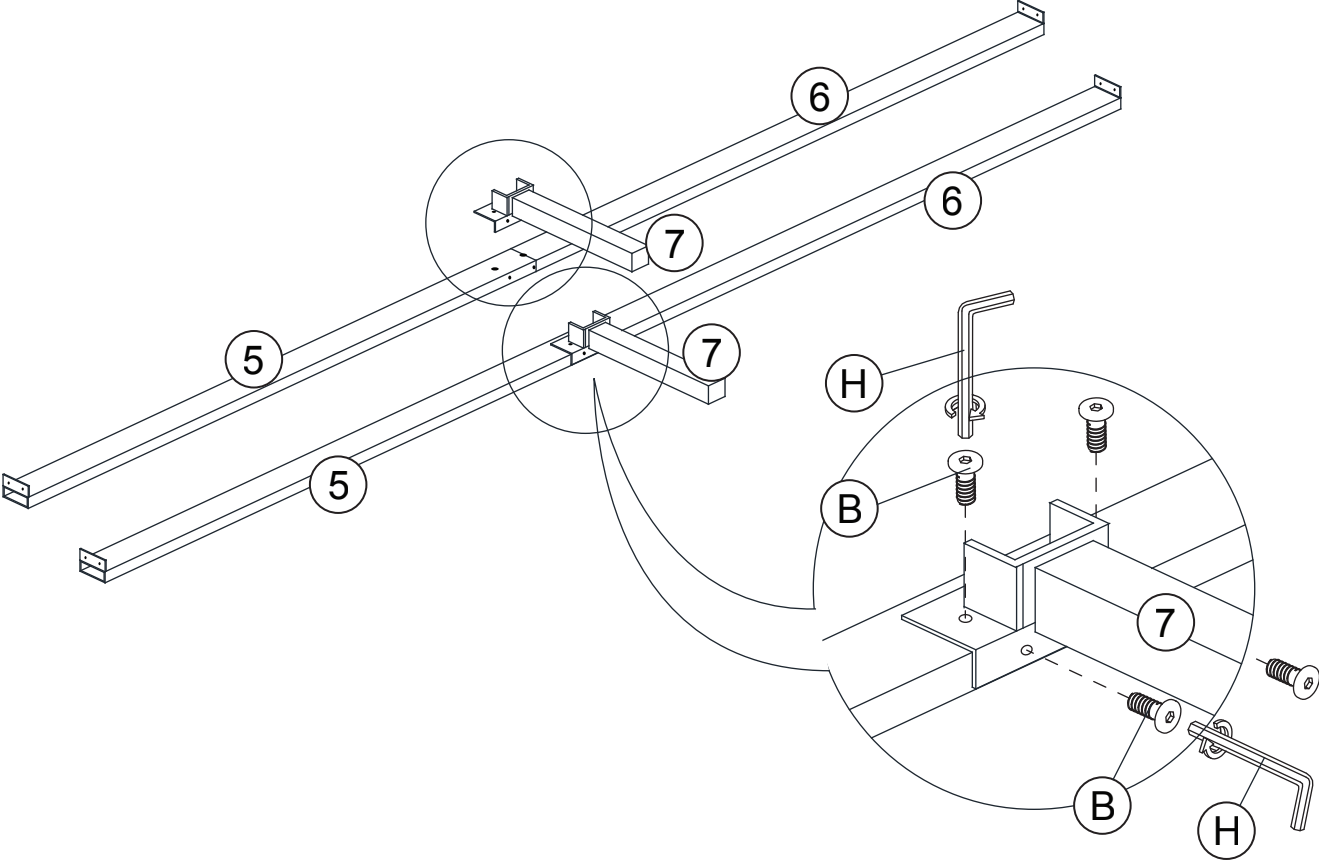

STEP 4

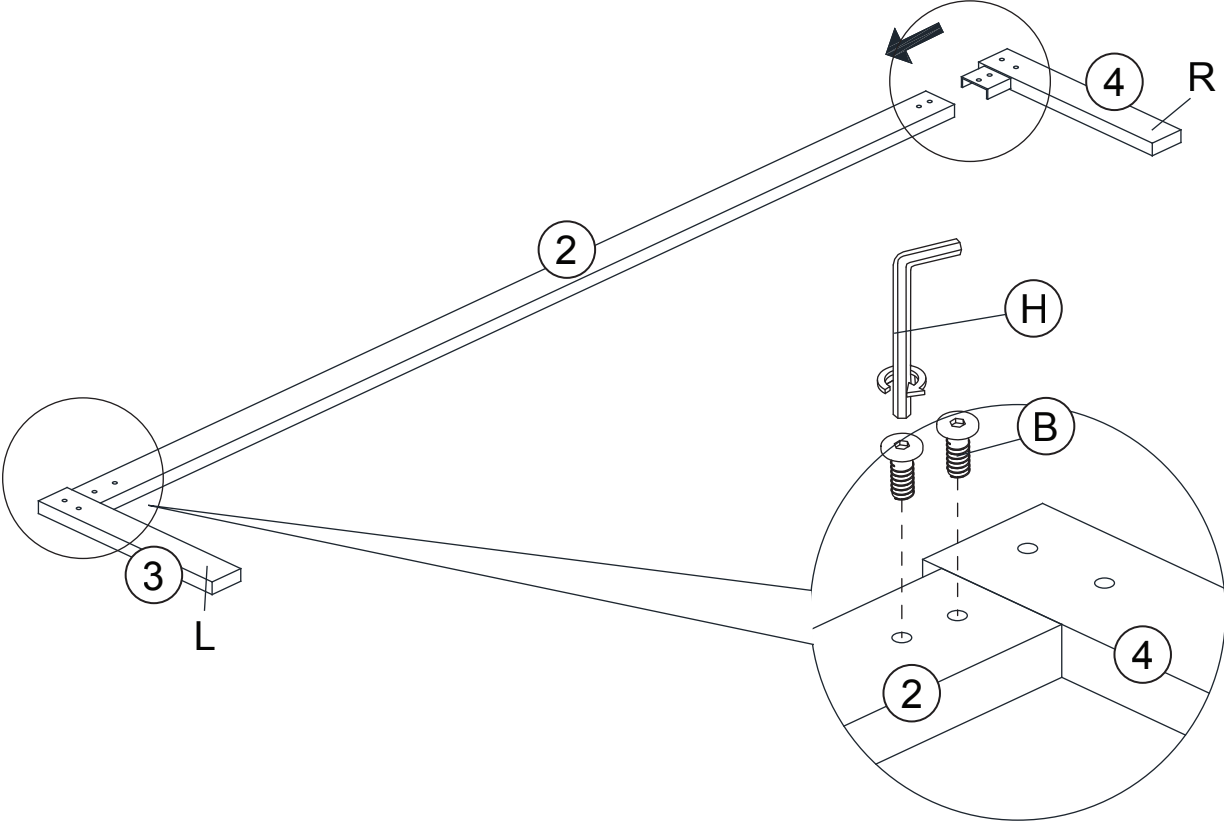

ASSEMBLY INSTRUCTION

STEP 5

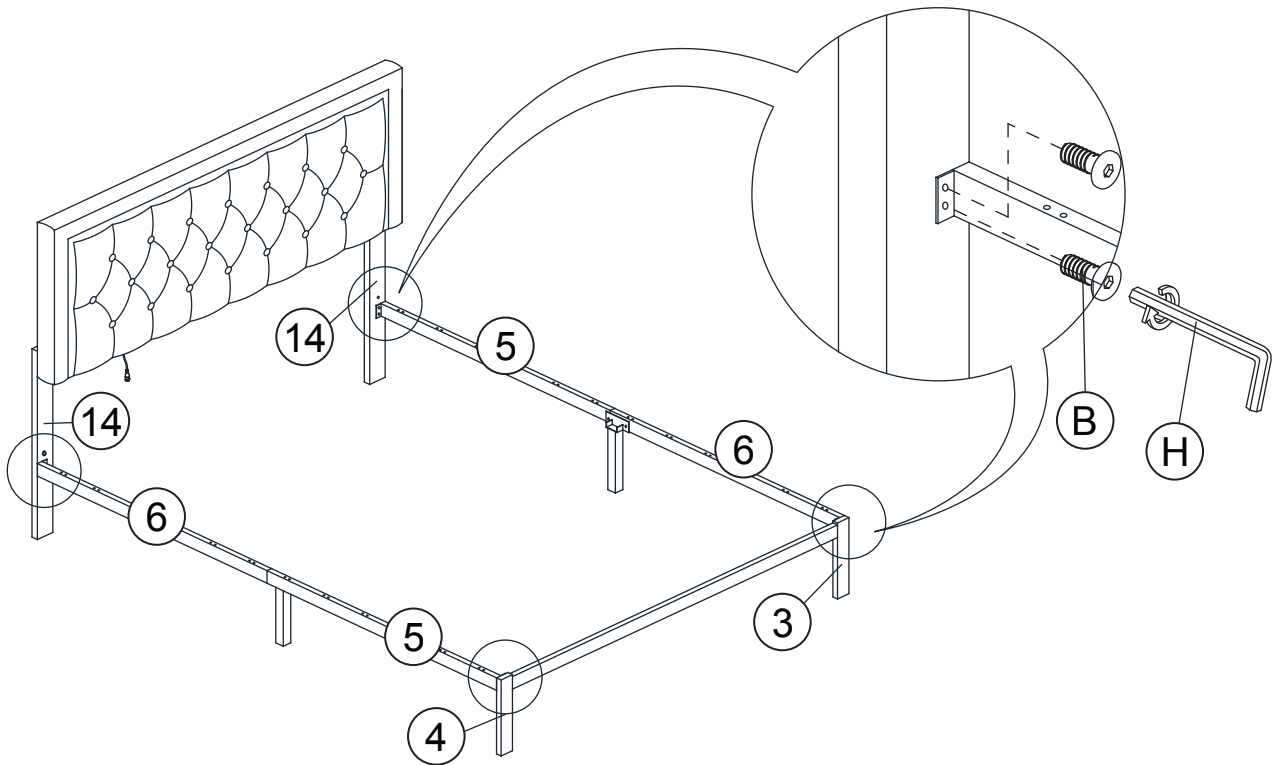

STEP 6

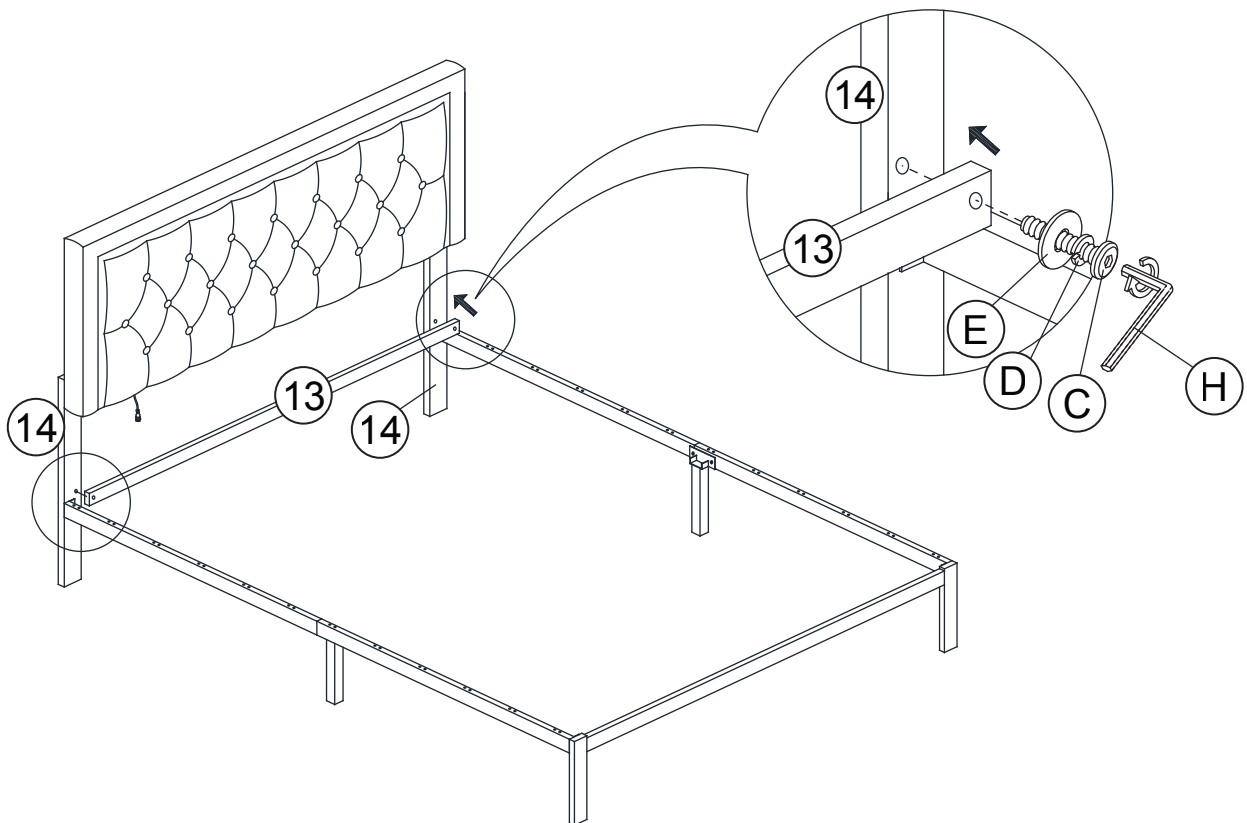

ASSEMBLY INSTRUCTION

STEP 7

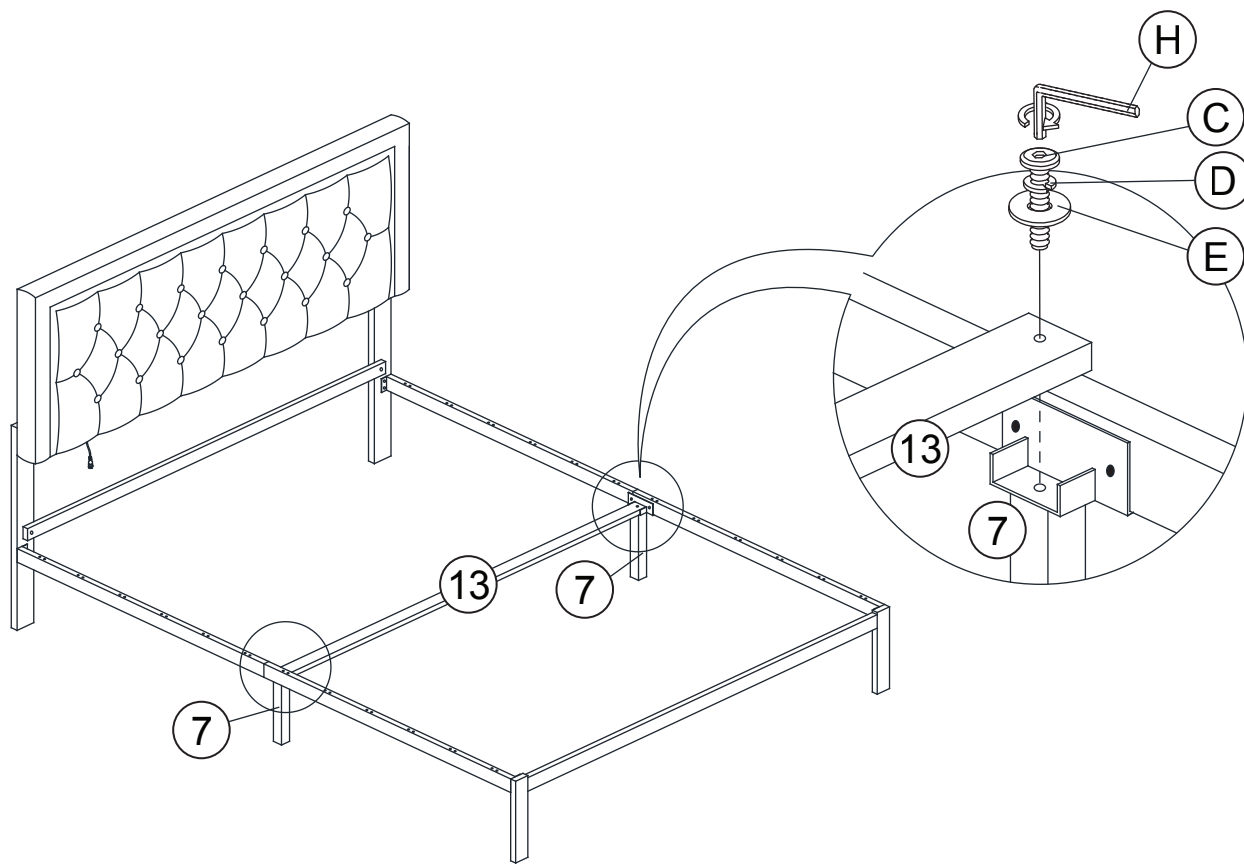

STEP 8

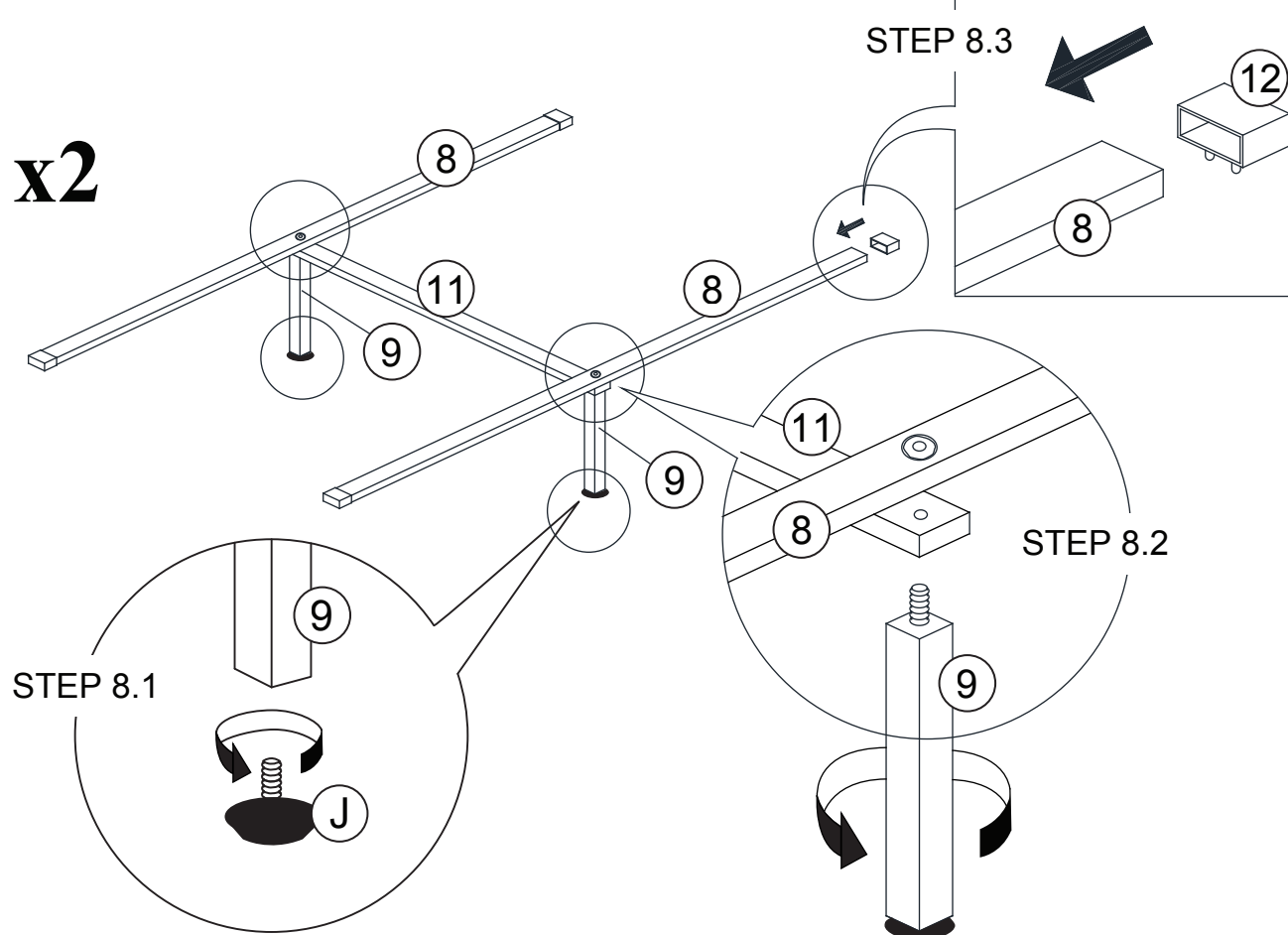

ASSEMBLY INSTRUCTION

STEP 9

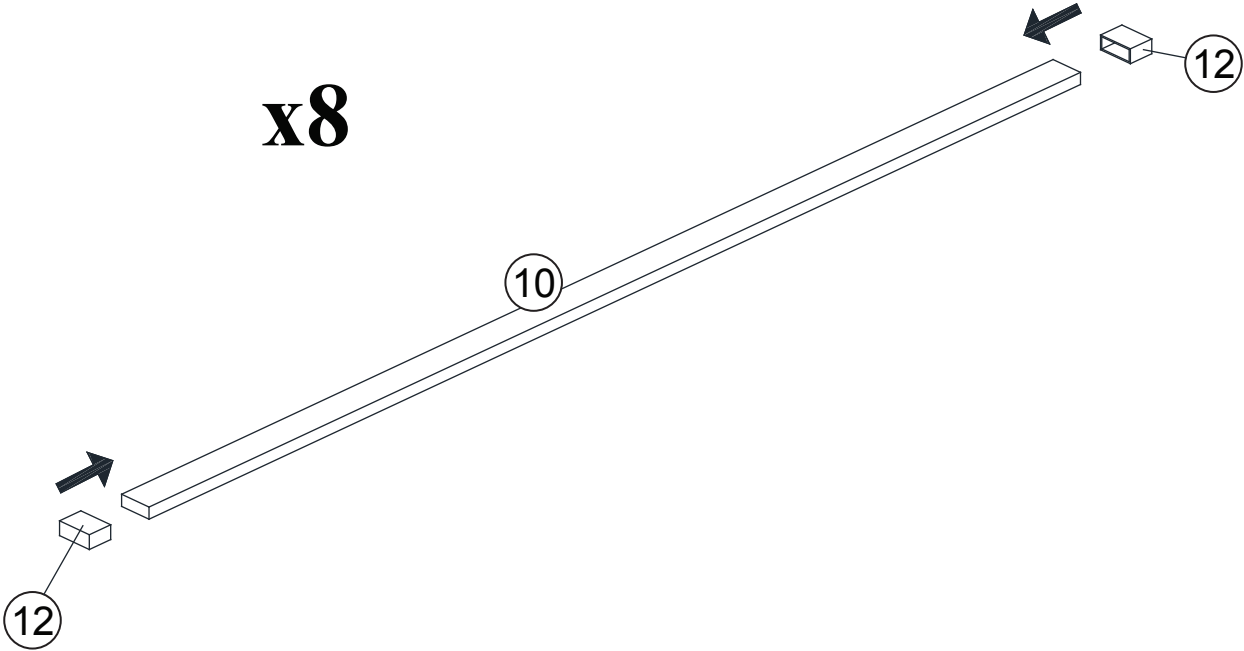

STEP 10

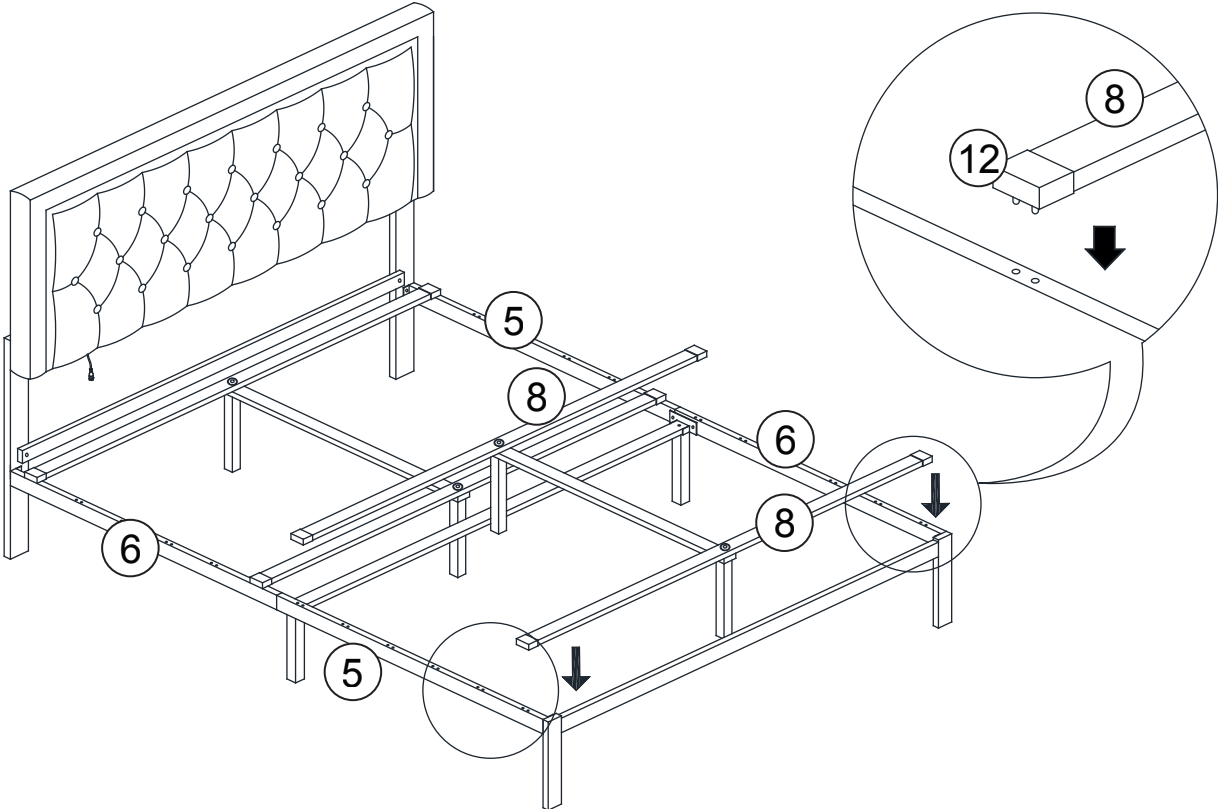

ASSEMBLY INSTRUCTION

STEP 11

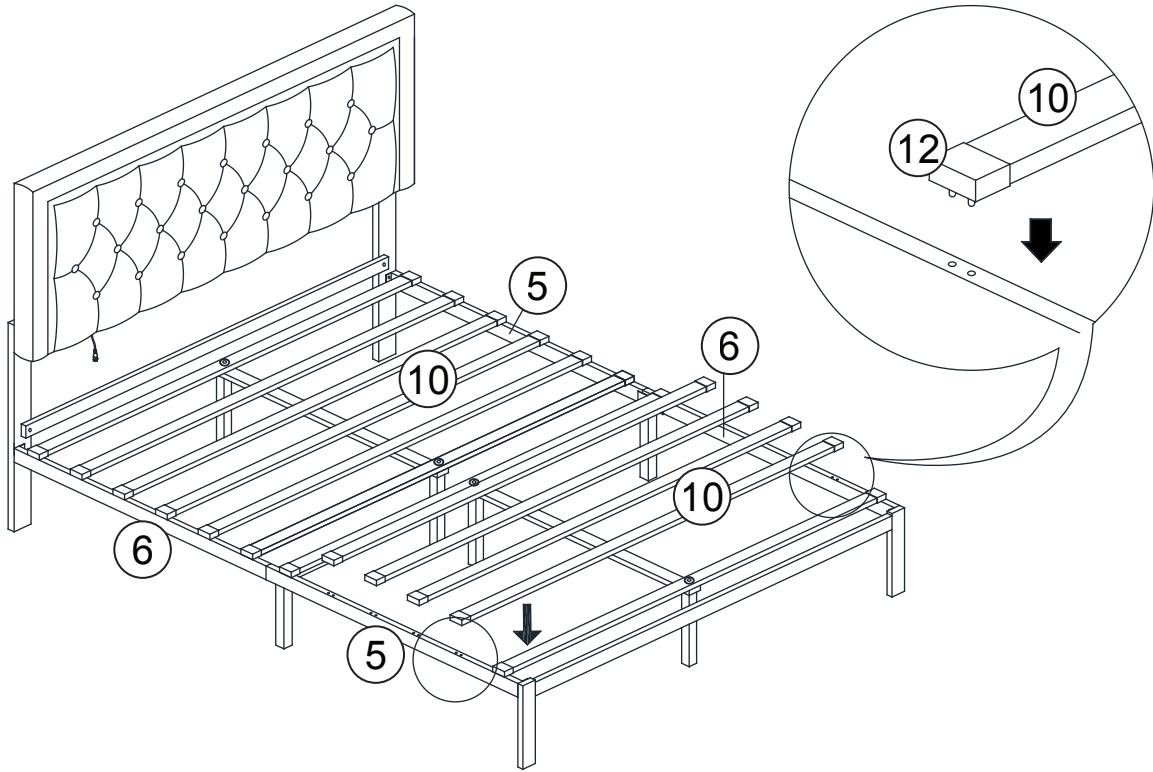

STEP 12

REMARK:
Clean the sticking part and keep it clean before sticking the velcro, to avoid affecting the stickiness.

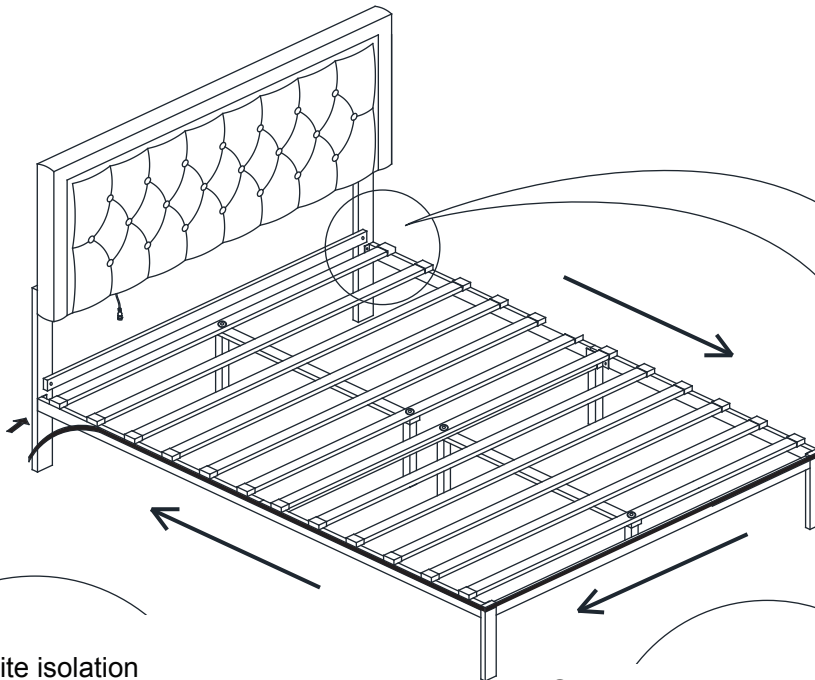

REMARK:
Tear off the white isolation paper on the back of velcro hook

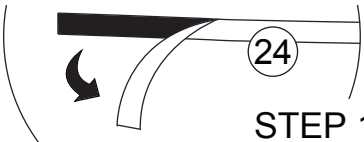

STEP 12.1

STEP 12.2

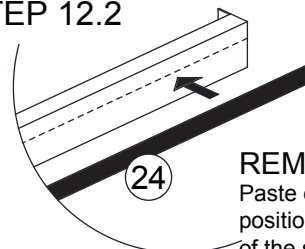

REMINER:
Paste on the upper position of the side view of the side rail as shown.

ASSEMBLY INSTRUCTION

STEP 13

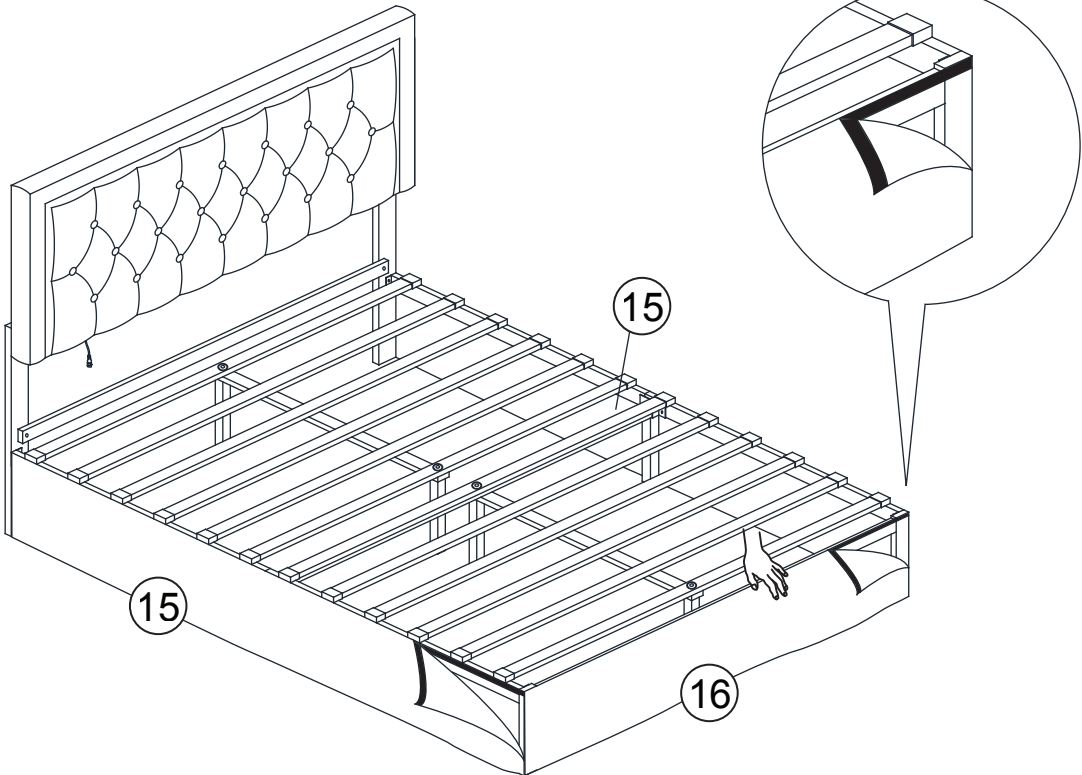

STEP 14

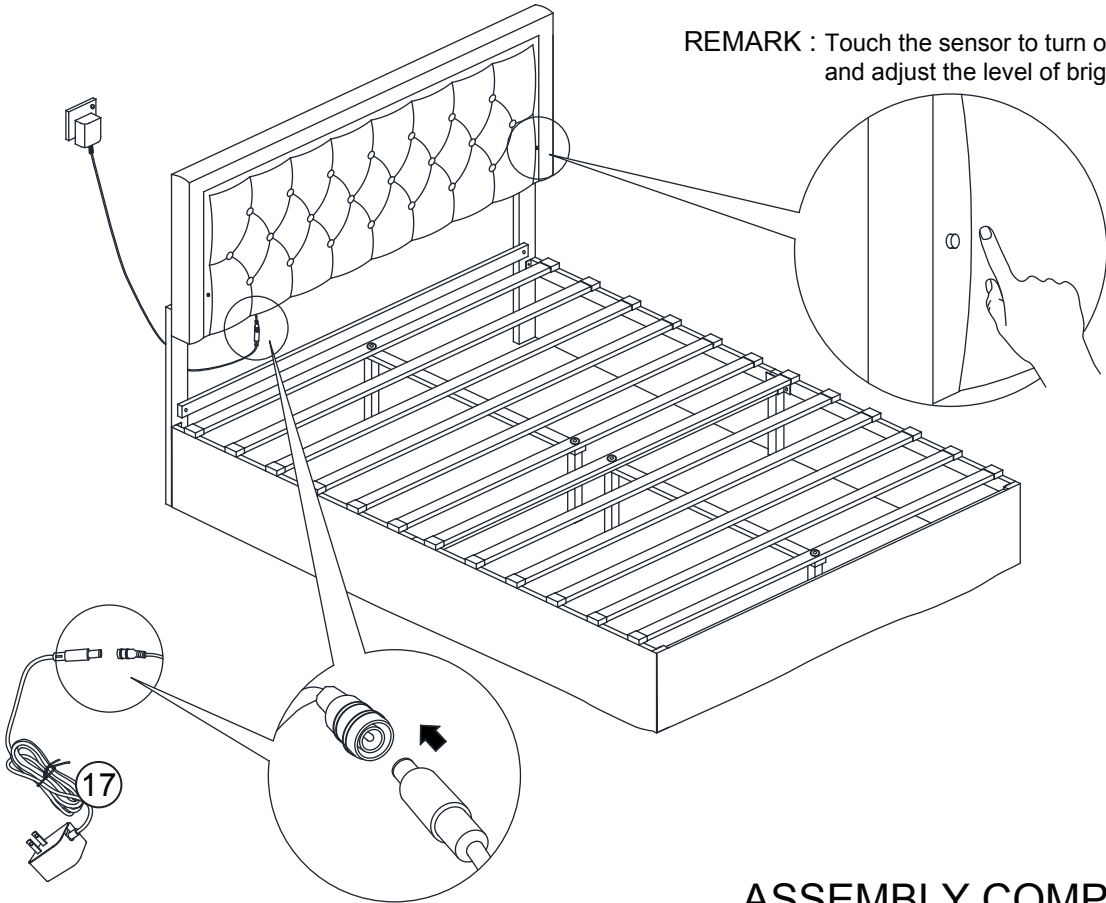

ASSEMBLY COMPLETED