

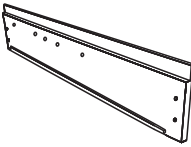

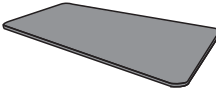

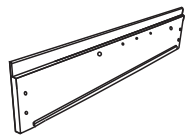



















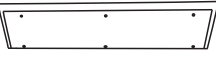
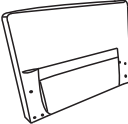



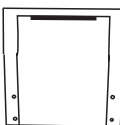

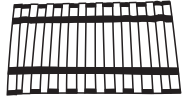

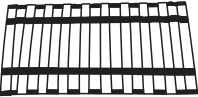
Part NO.	Part Image	Part Name	QTY	Part NO.	Part Image	Part Name	QTY
A		Chaise Left Side Board	1	M		Chaise Seat Board	1
B		Chaise Right Side Board	1	N		Chaise Seat Frame	1
C		Chaise Front Board	1	O-R		Right Spring Hinge	1
D-L		Left Connect Metal	3	O-L		Left Spring Hinge	1
D-R		Right Connect Metal	3	P		USB Charger	1
E	 M6x20mm	Screws	41	Q		Liminting Stopper	2
F		Allen Key	1	R		Connect Road of 2 Seater	1
G	 M6x55mm	Screws	2	S		2-Seater Backrest	1
H		Gasket	2	T		Pullout Bed Seat Frame	1
I		Legs	6	U		Pullout Bed Front Board	1
J		Left Armrest	1	V		Pullout Bed Bar	1
K		Right Armrest	1	W	 M6x40mm	Screws	6
L		Chaise Backrest	1	X		Pull Belt Of Chaise	1
				Y		Pull Belt Of 2 Seat	1

Part NO.	Part Image	Part Name	QTY	Part NO.	Part Image	Part Name	QTY
Z		Chaise & Pullout Bed Slat	2	e		Armrest Pillows	2
a		2 Seater Slat	1	f		Back Cushions	3
b		Chaise Seat Cushion	1	g	 M8x20mm	Screws	1
c		2 Seater Seat Cushion	2	A1		Pull Out Bed Wheel	2
d		Pullout Bed Seat Cushion	1	A2		Screw M4*10	4
				A3		M2.5 Allen Key	1

**STEP 1 SOME PARTS ARE INSIDE THE ARMRESTS, PLEASE OPEN THE VELCRO ON THE BOTTOM OF ARMRESTS TO TAKE THEM OUT WHEN YOU ASSEMBLE THE SOFA.**

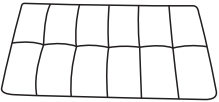

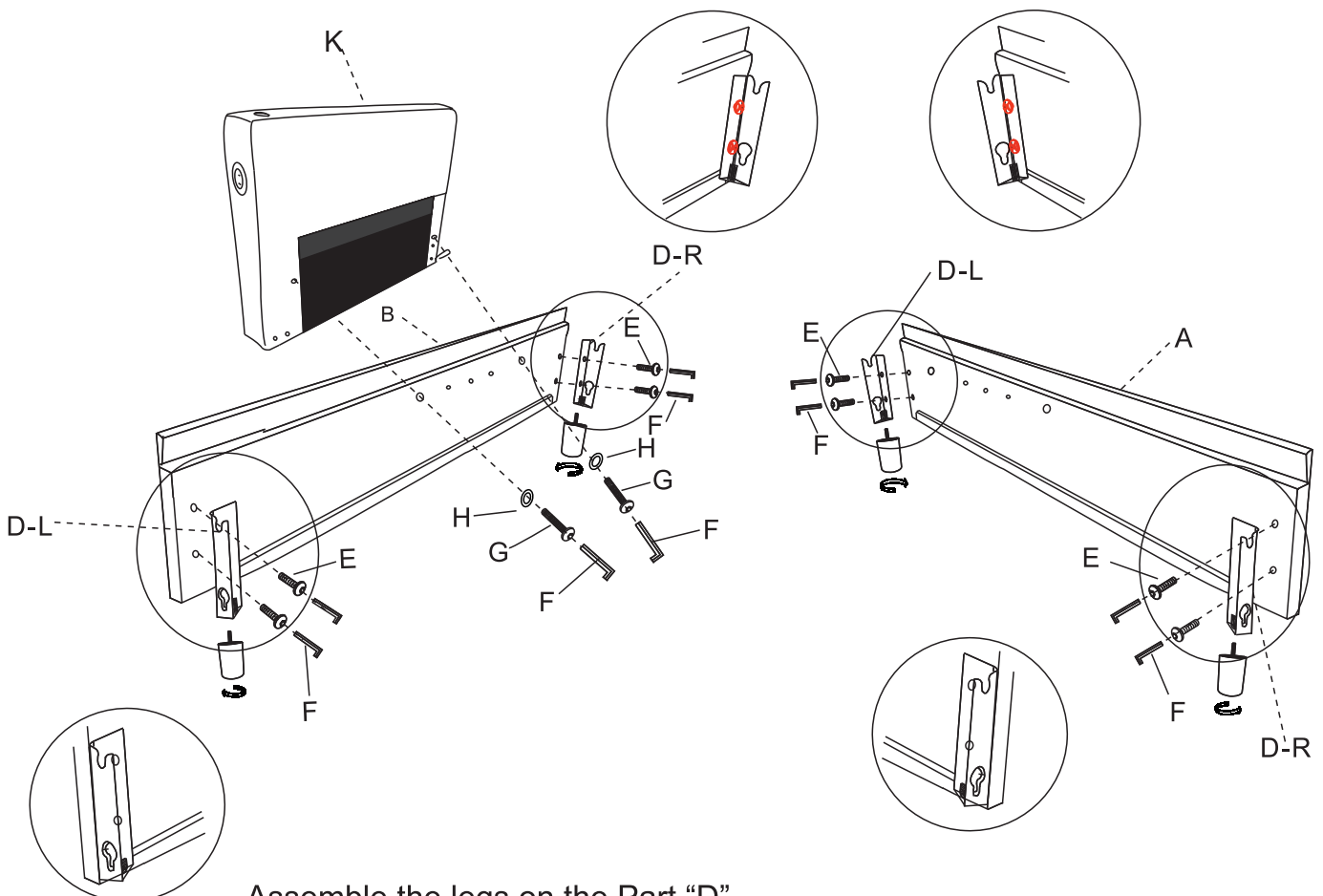
Assemble the legs on the Part "D"  
 Connect the Part "B" and Armrest "K" with Screws "G" "H"  
 Connect the Part "D" and "A" "B" with Screws "E"

**STEP 2**

Insert the Screws "E" into Part "C" but do not tighten fully, then slide Screws "E" into Part "D" to tighten the screws fully at that time

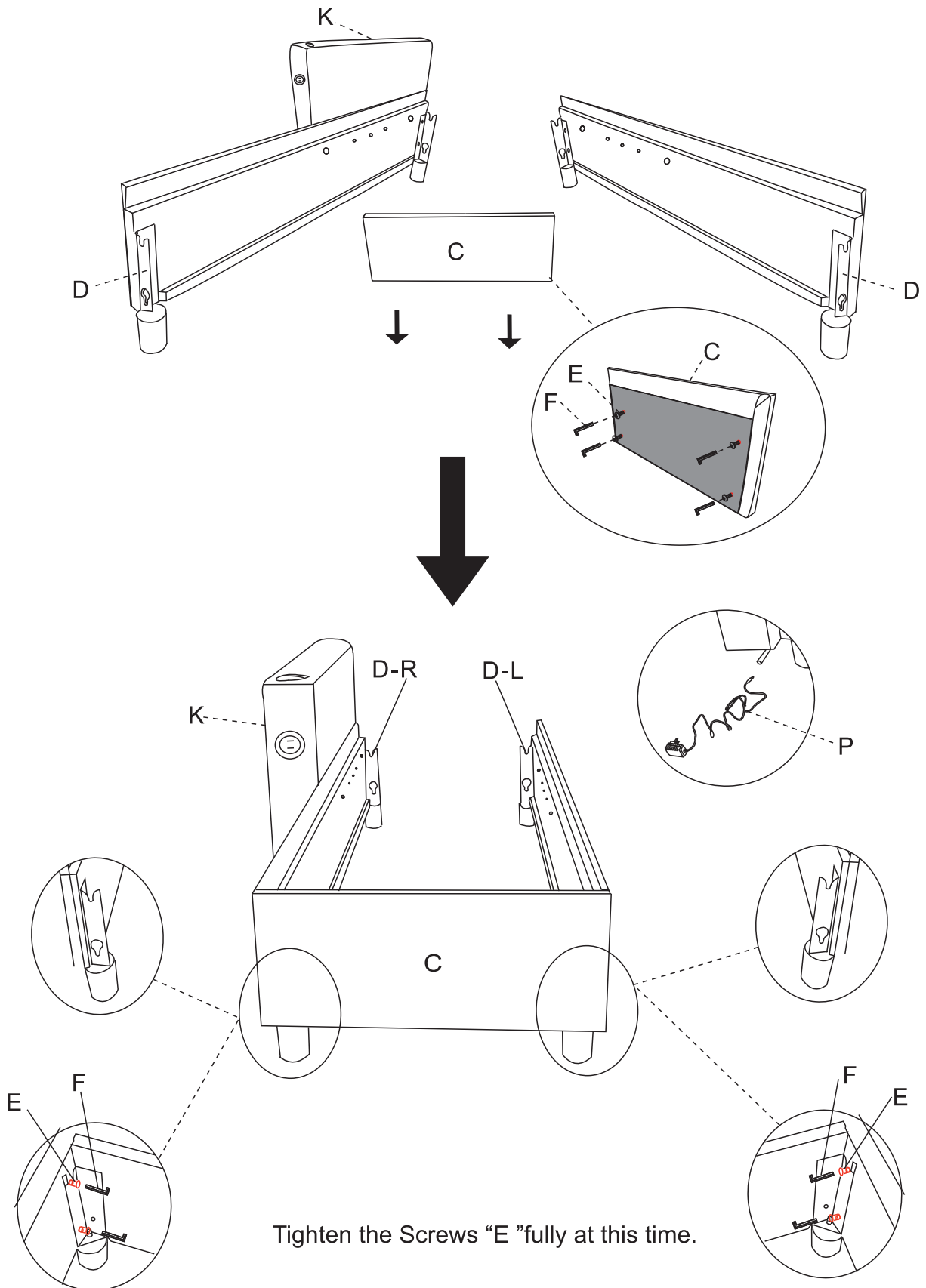

**STEP 3**

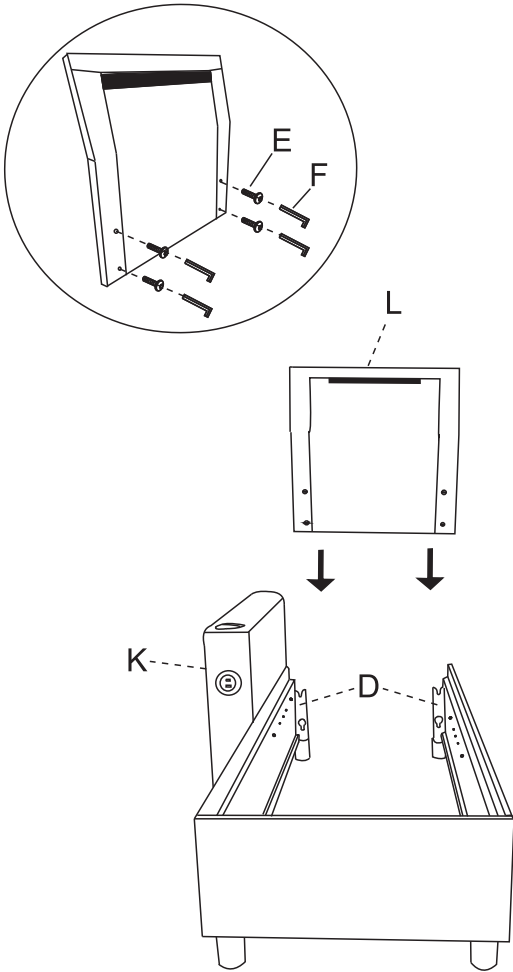

**STEP 4**

Insert the Screws "E" into Part "L" but do not tighten fully, then slide the Screws "E" into Connect Metal "D" to tighten the screws fully at that time

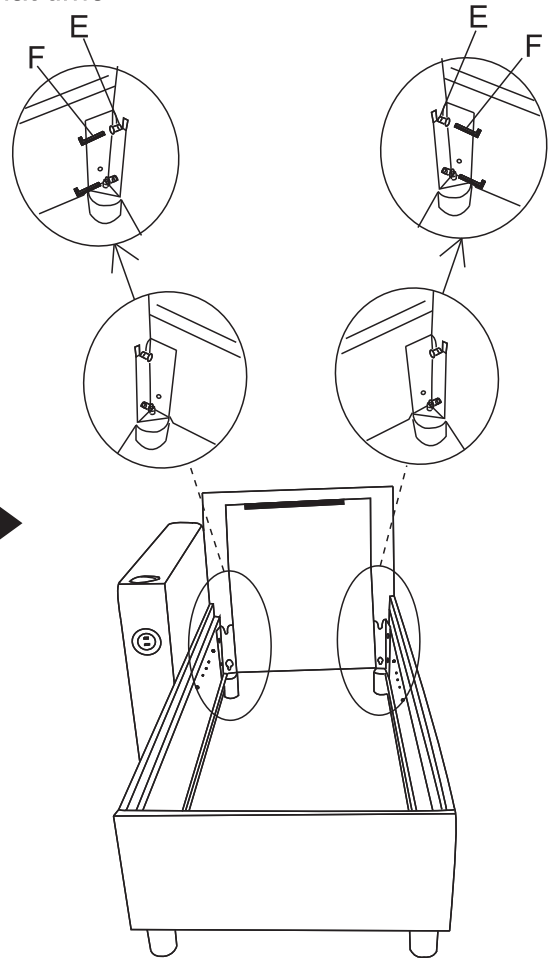

**STEP 5** Put the Chaise Seat Board "M" inside

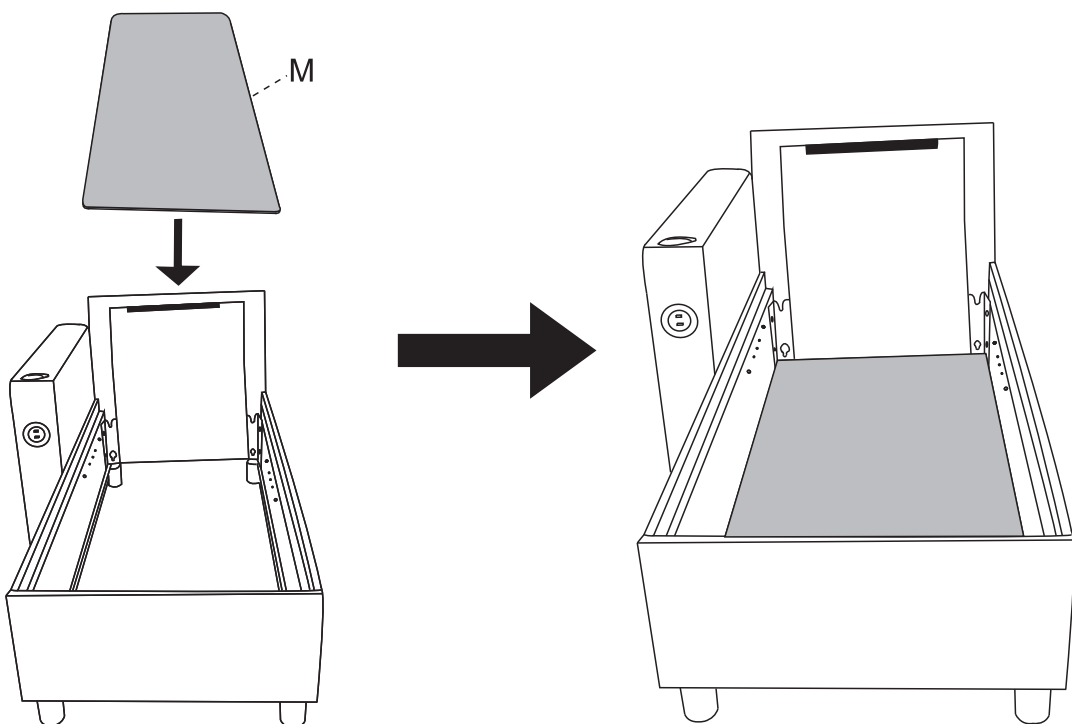

**STEP 6**

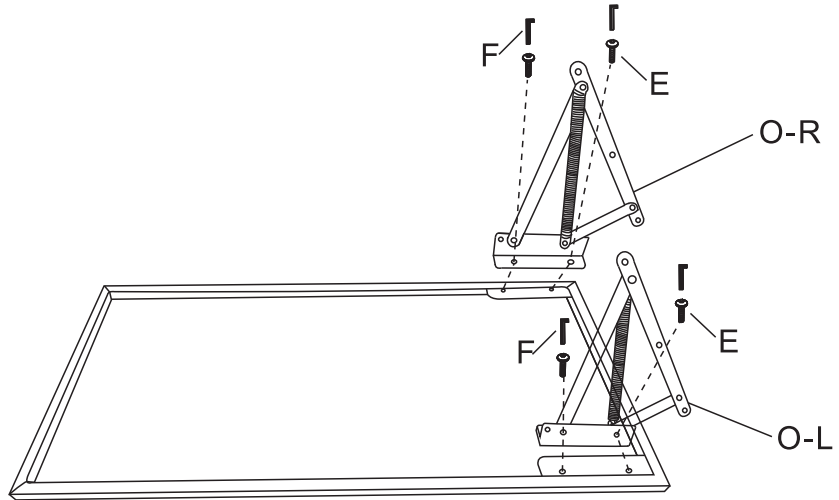

**STEP 7**

Insert 3 pieces Screws "E" separately into both side board

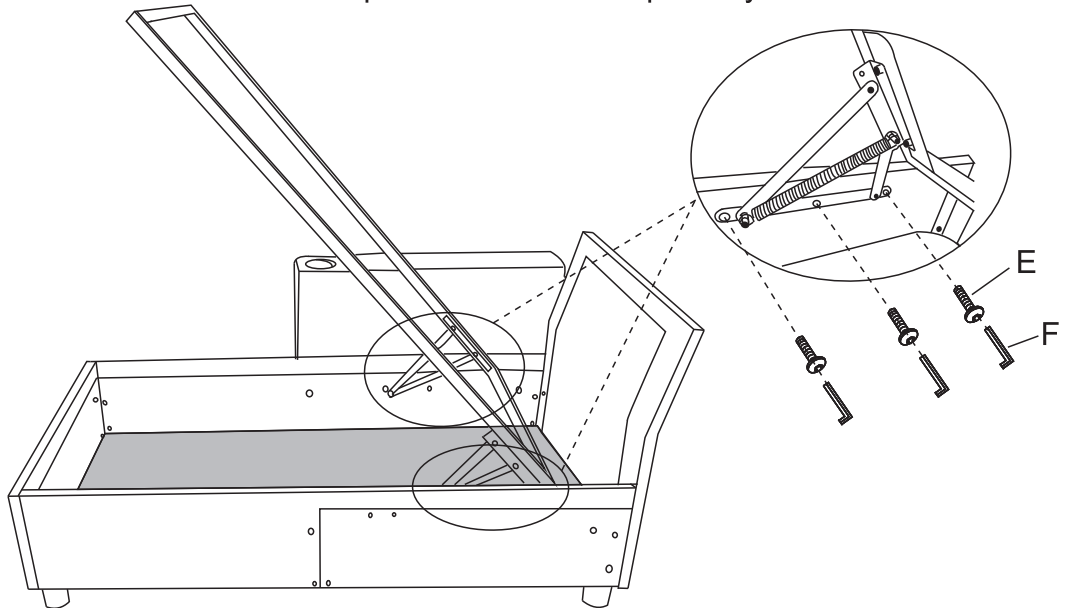

**STEP 8** Push down the Panel N

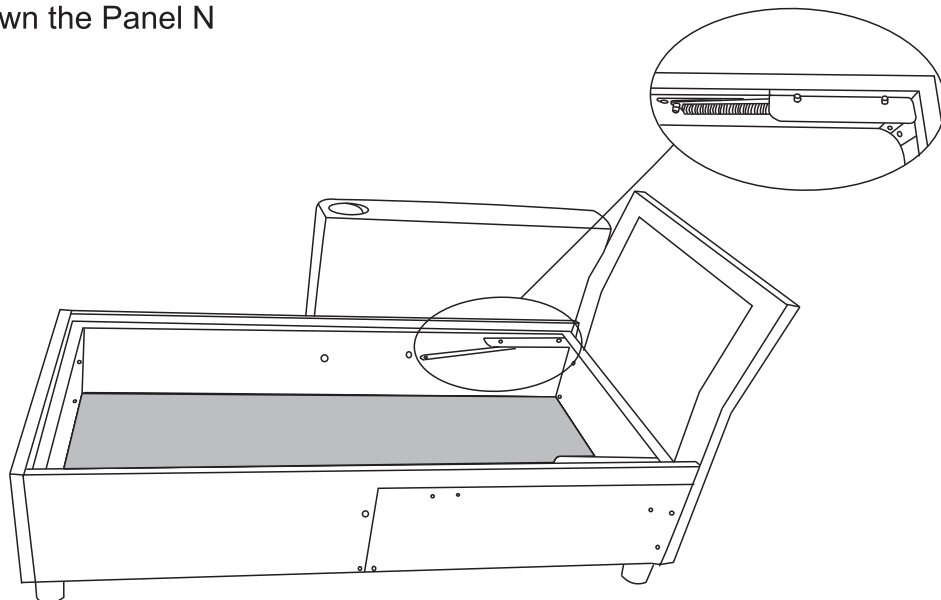

**STEP 9**

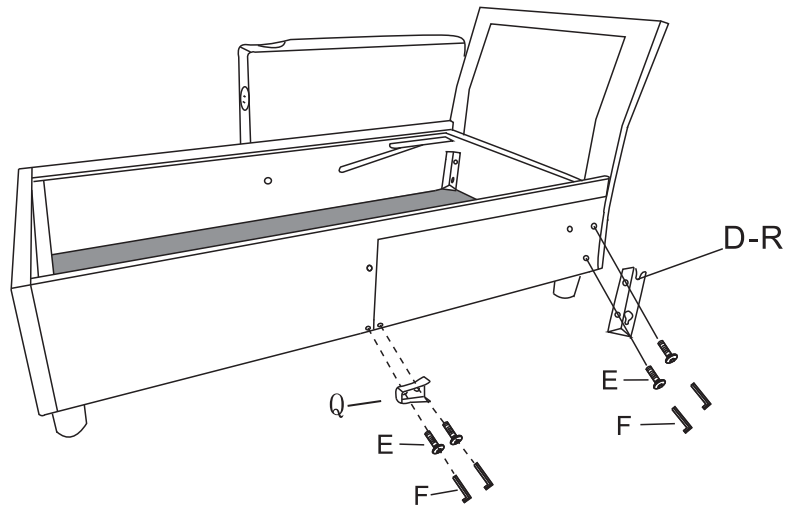

**STEP 10**

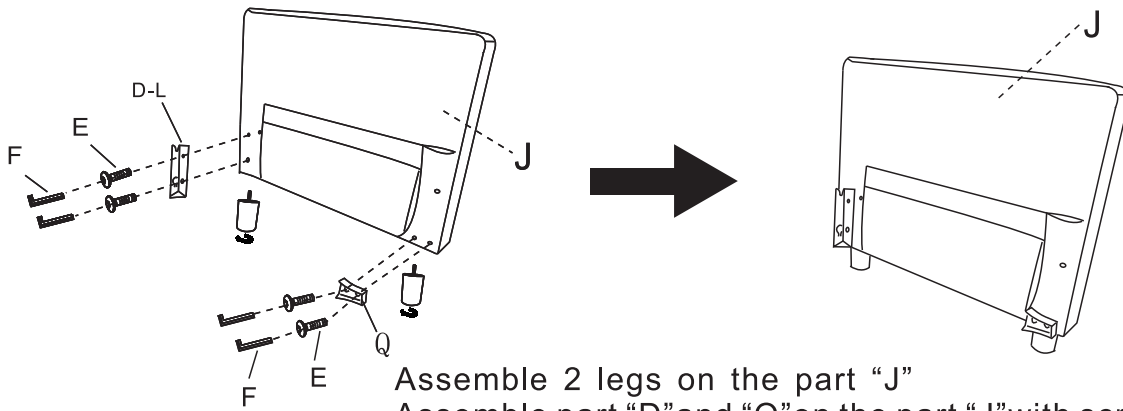

Assemble 2 legs on the part "J"  
Assemble part "D" and "Q" on the part "J" with screws "E"

**STEP 11**

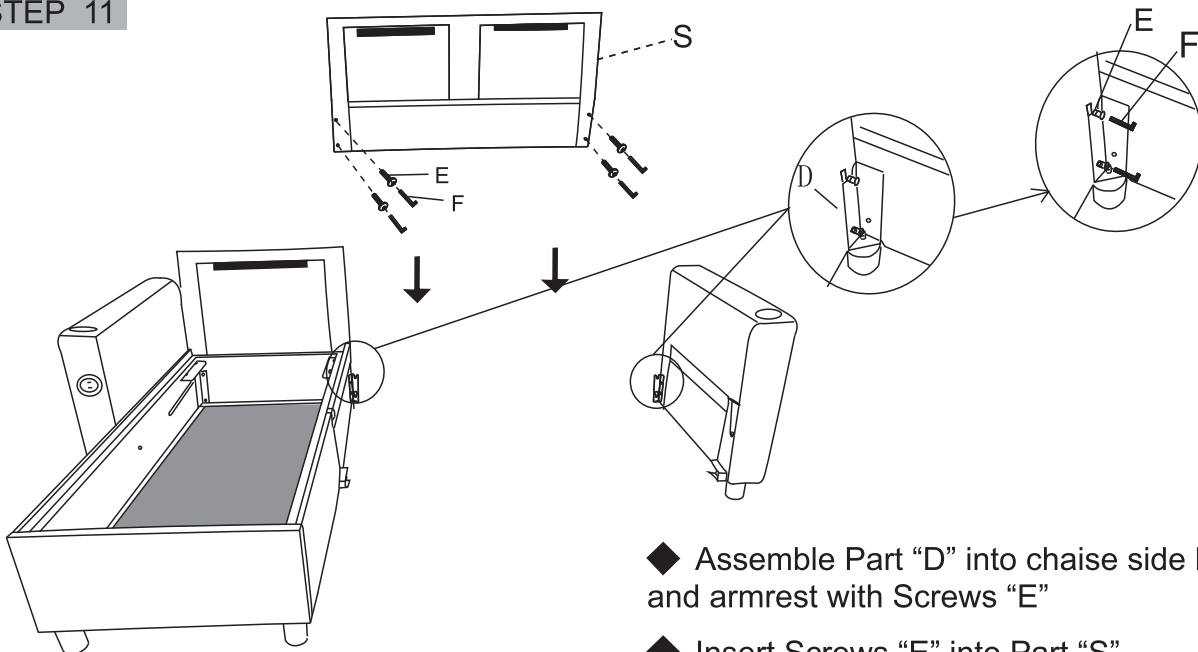

- ◆ Assemble Part "D" into chase side board and armrest with Screws "E"
- ◆ Insert Screws "E" into Part "S", but Do Not Tighten Fully, then slide the Screws "E" into Connect Metal "D"  
**Please tighten after next step finished**

STEP 12

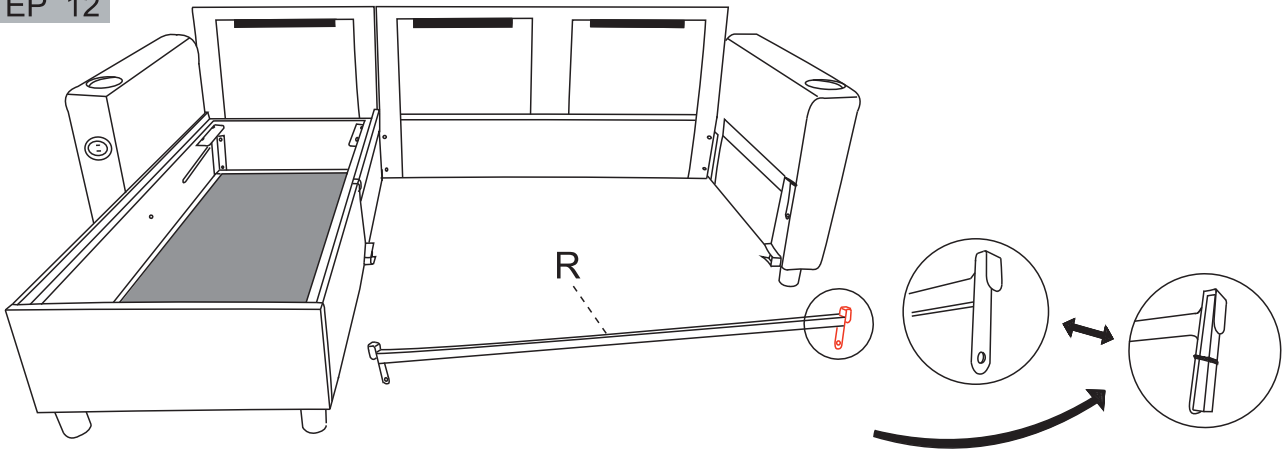

Remove small pieces protective wood while assembling

STEP 13

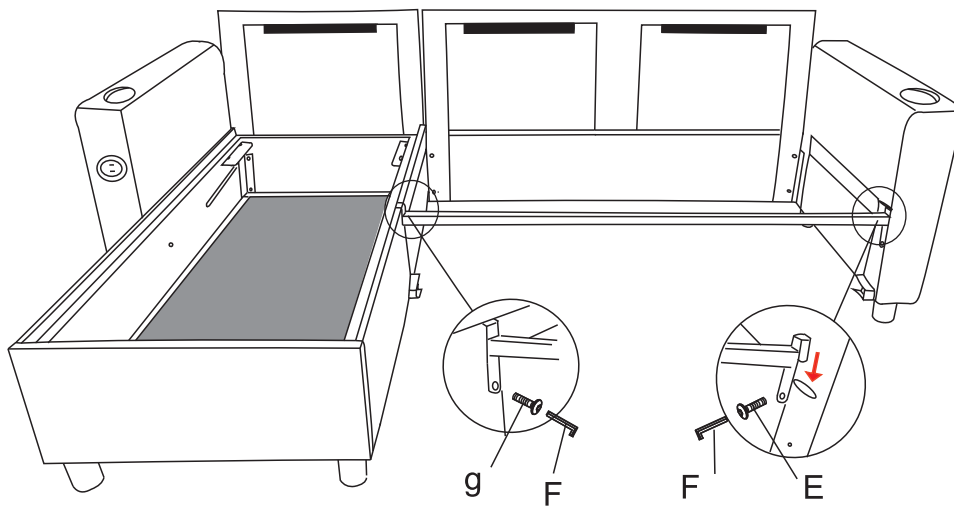

Insert this Part "R" into the hole on the armrest securing fabric and wood together. Then insert another side of Part "R" into the edge of the chaise side board . Then insert Screws "g" into the chaise side board. Then insert Screws "E" into armrest to fix "R". Finally tighten all Screws including "E " on Part "S".

STEP 14

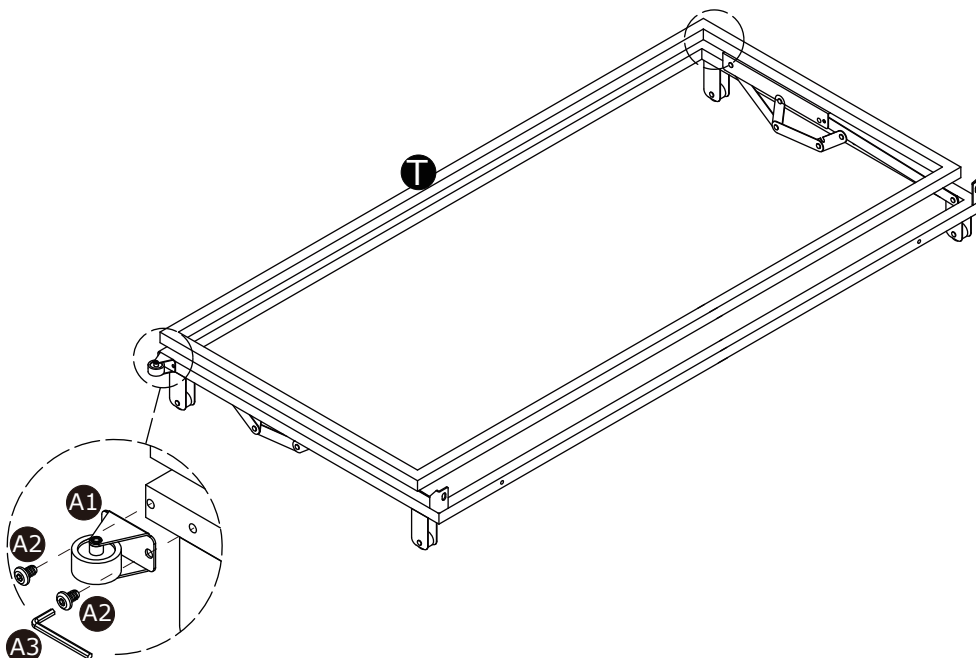

**STEP 15**

Tighten all screws fully after next step finished.

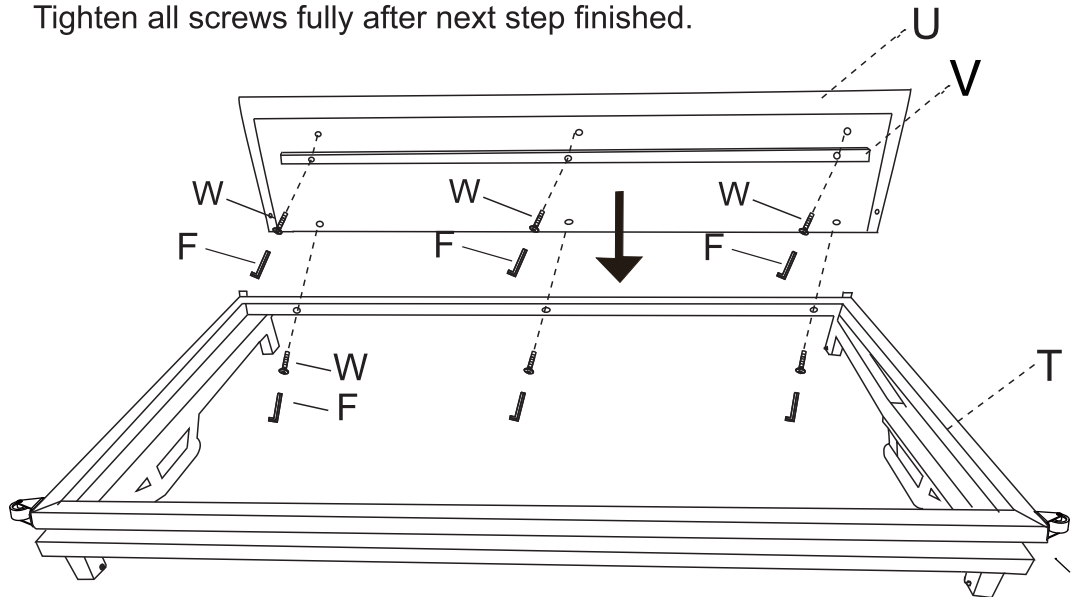

**STEP 16**

Tighten all screws including Screws "W" when you finish this step.

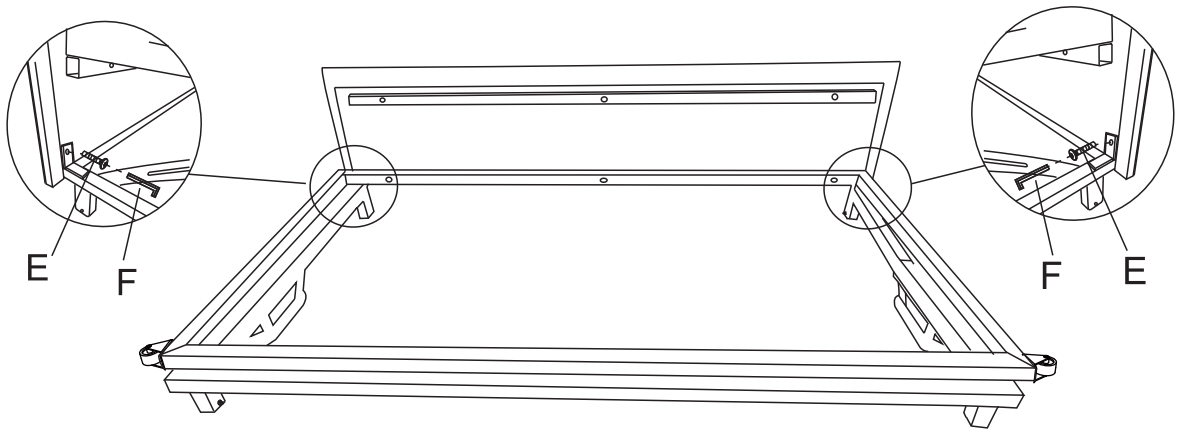

**STEP 17**

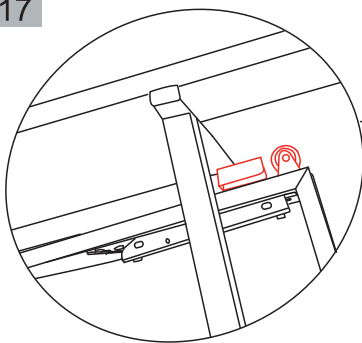

Slide Part "T" inside

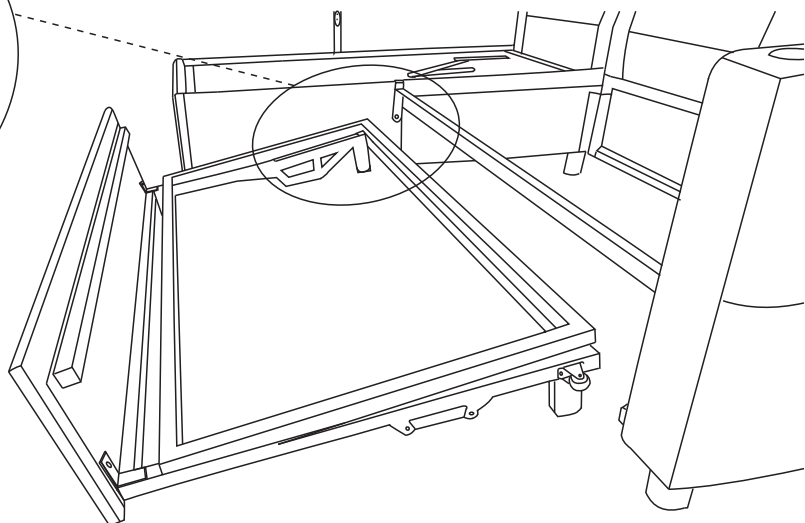

STEP 18

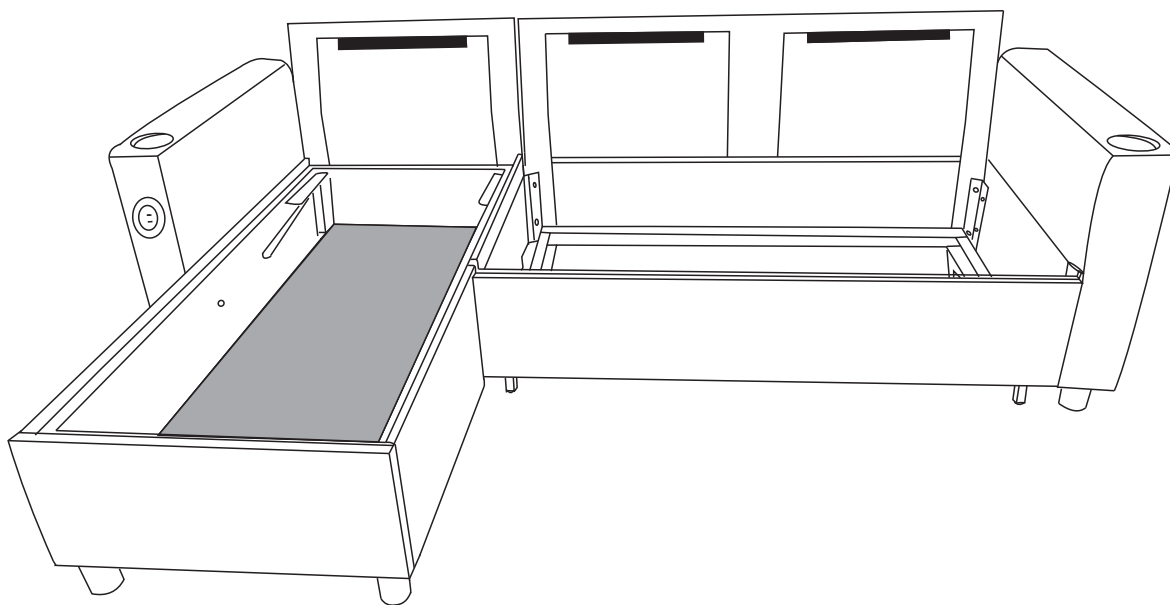

STEP 19

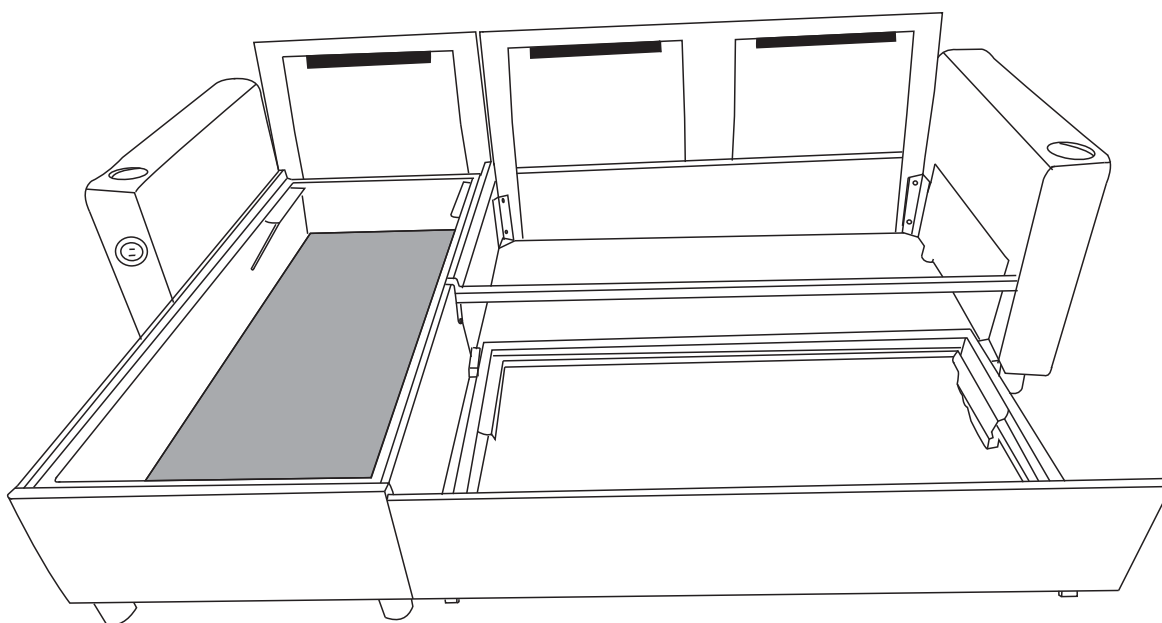

STEP 20

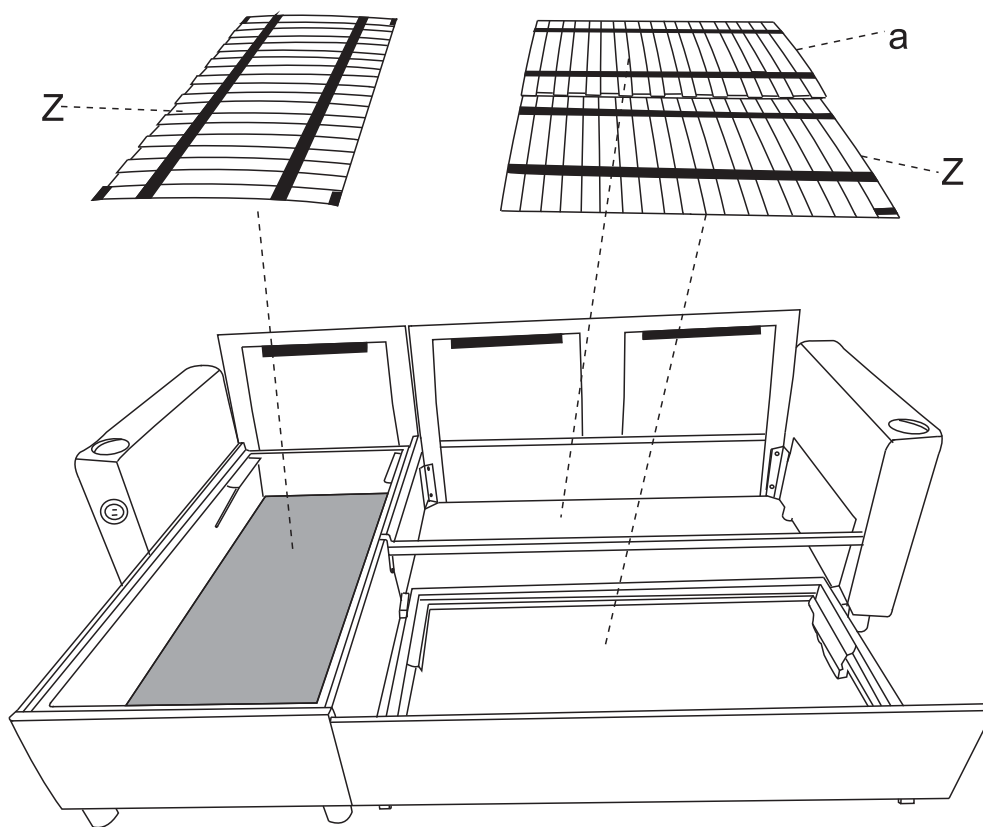

STEP 21

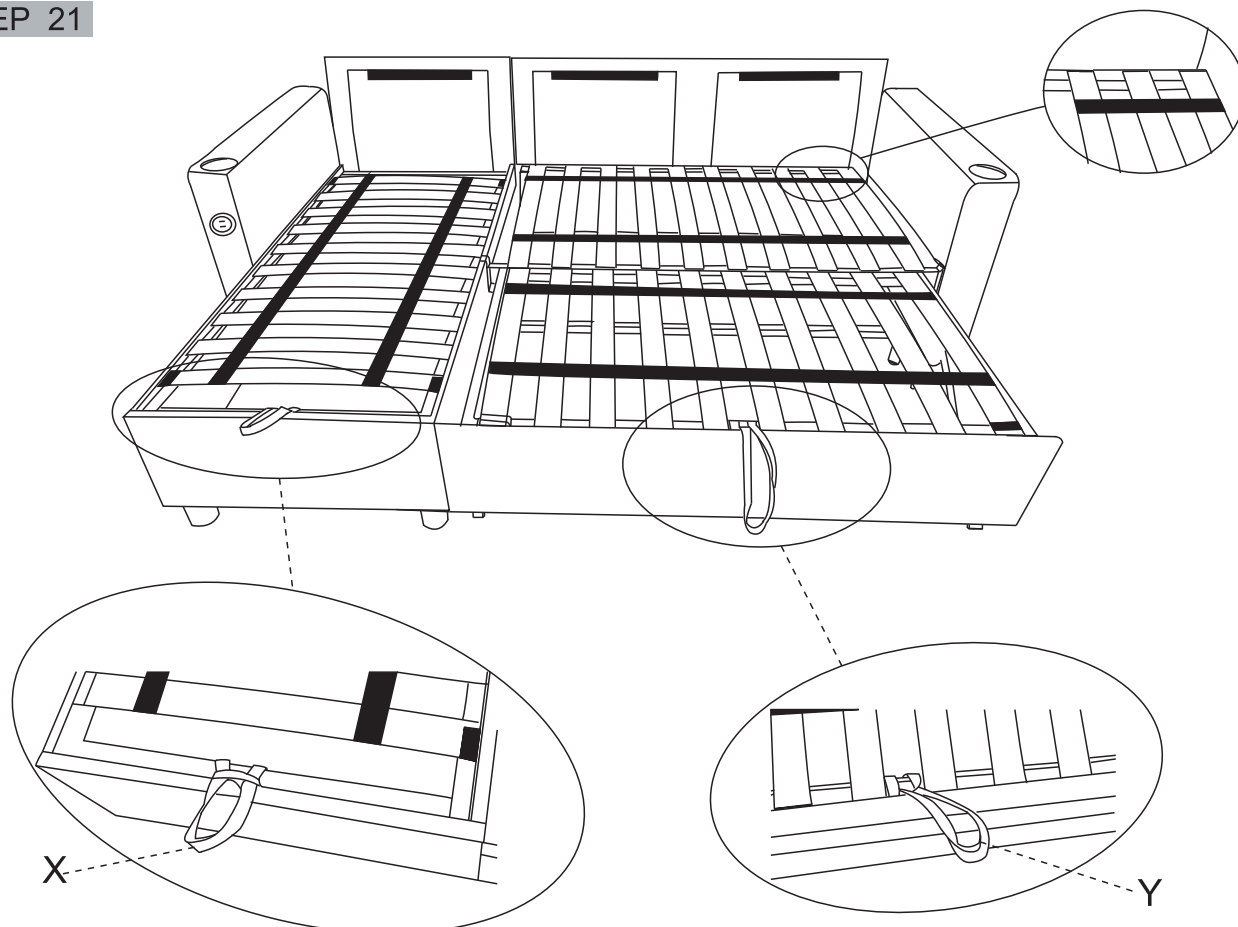

STEP 22

Push the backrest forward first then lay down the backrest **COMPLETELY** and then lift up the backrest to each angle as you need

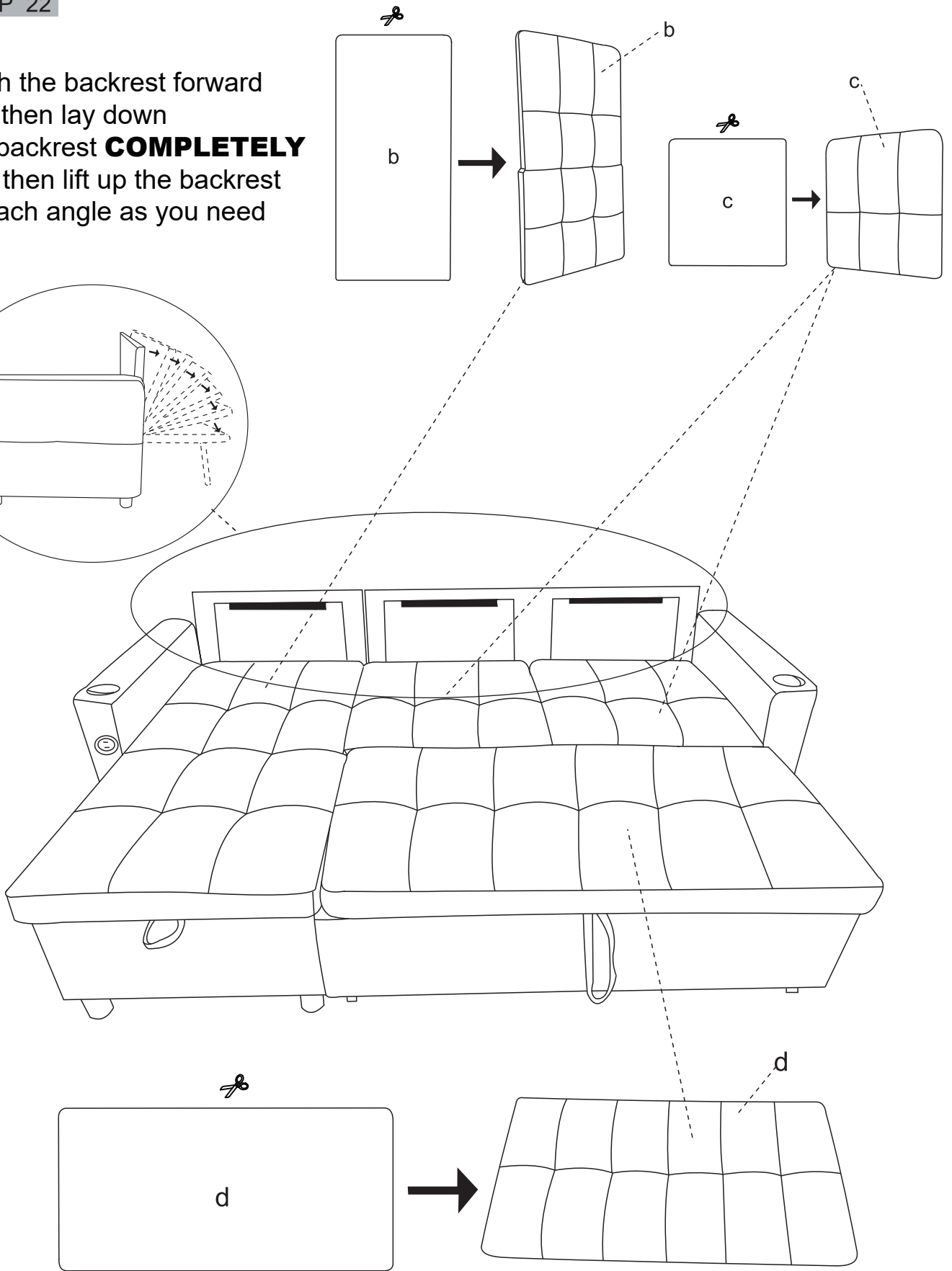
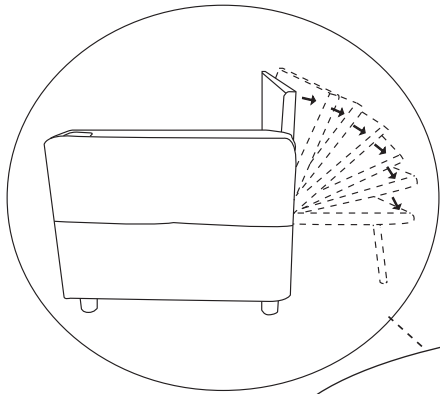

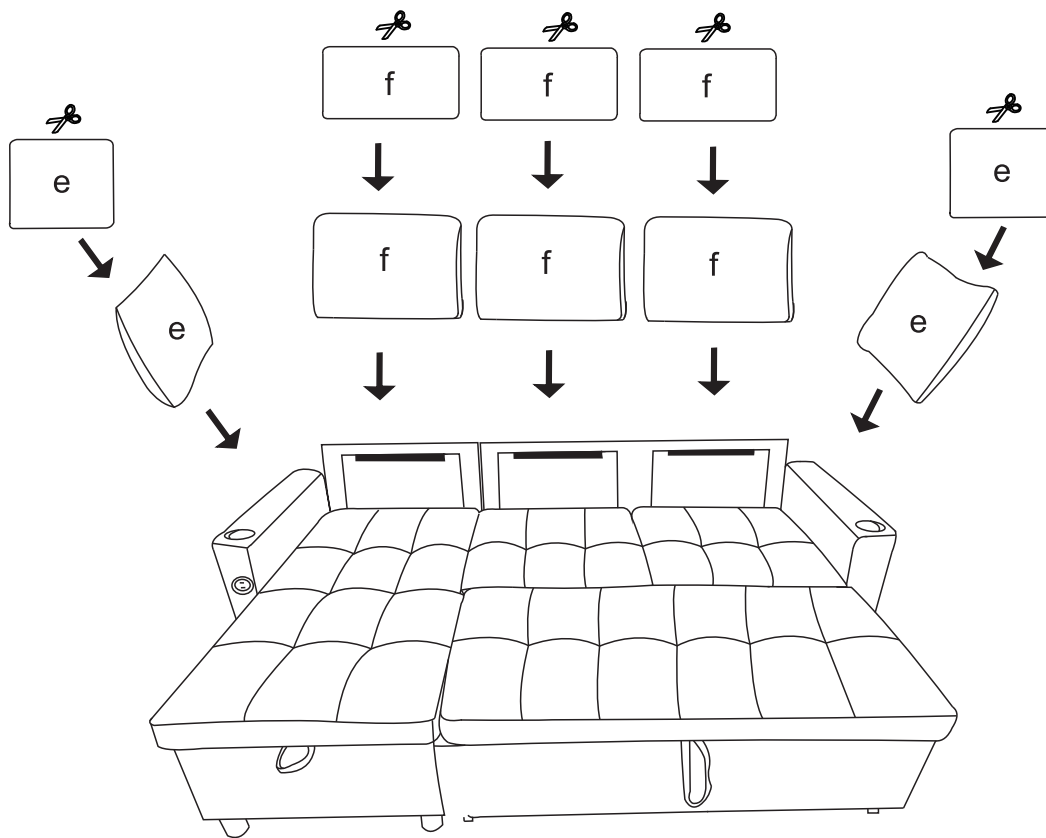

All the seat cushions and back cushions are compressed, before using, please allow 72H for the pillows and cushions to inflate totally

### Another Side Chaise Assembly

#### STEP 1

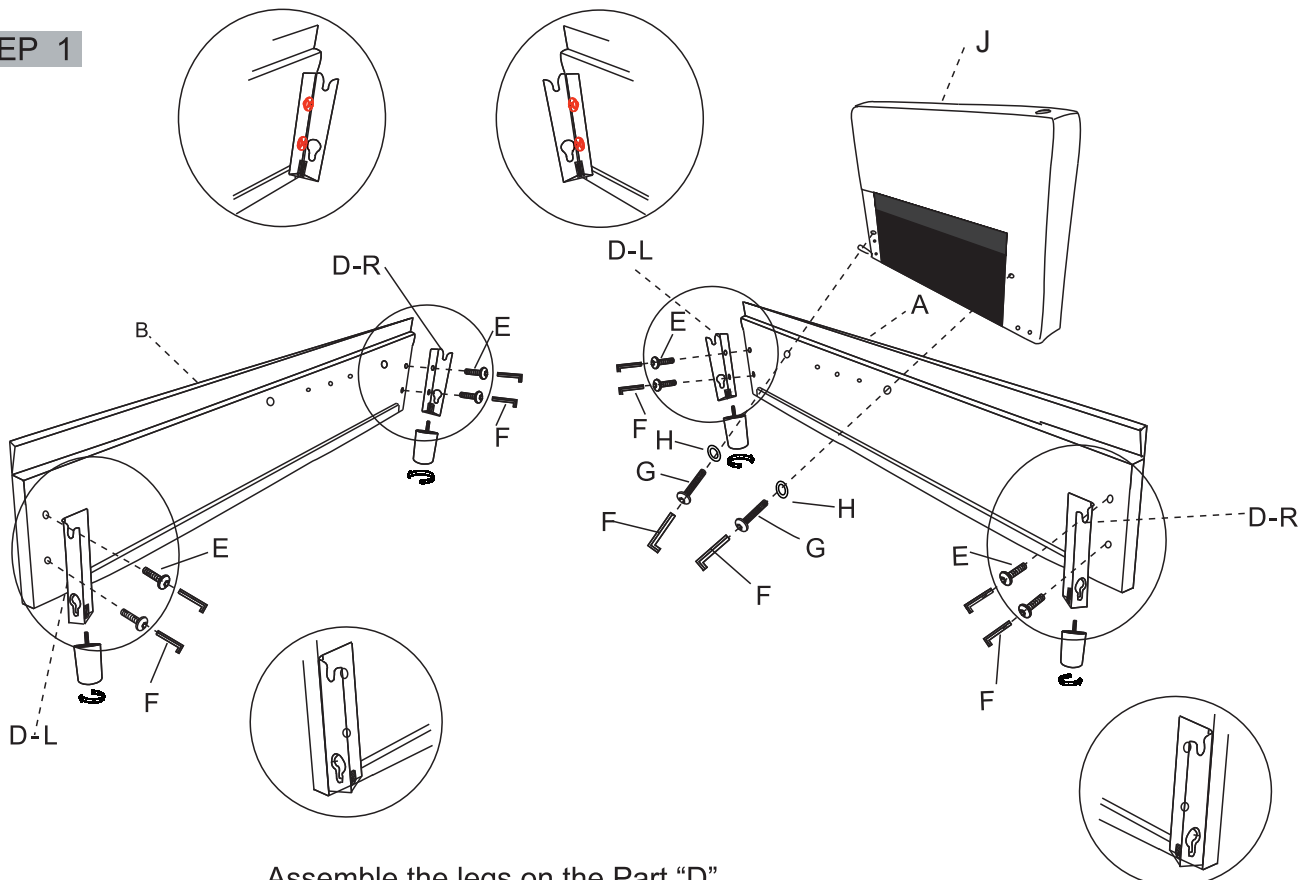

Assemble the legs on the Part "D"  
 Connect the Part "A" and Armrest "J" with Screws "G" "H"  
 Connect the Part "D" and "A" "B" with Screws "E"

**STEP 2**

Insert the Screws "E" into Part "C" but do not tighten fully, then slide Screws "E" into Part "D" to tighten the screws fully at that time

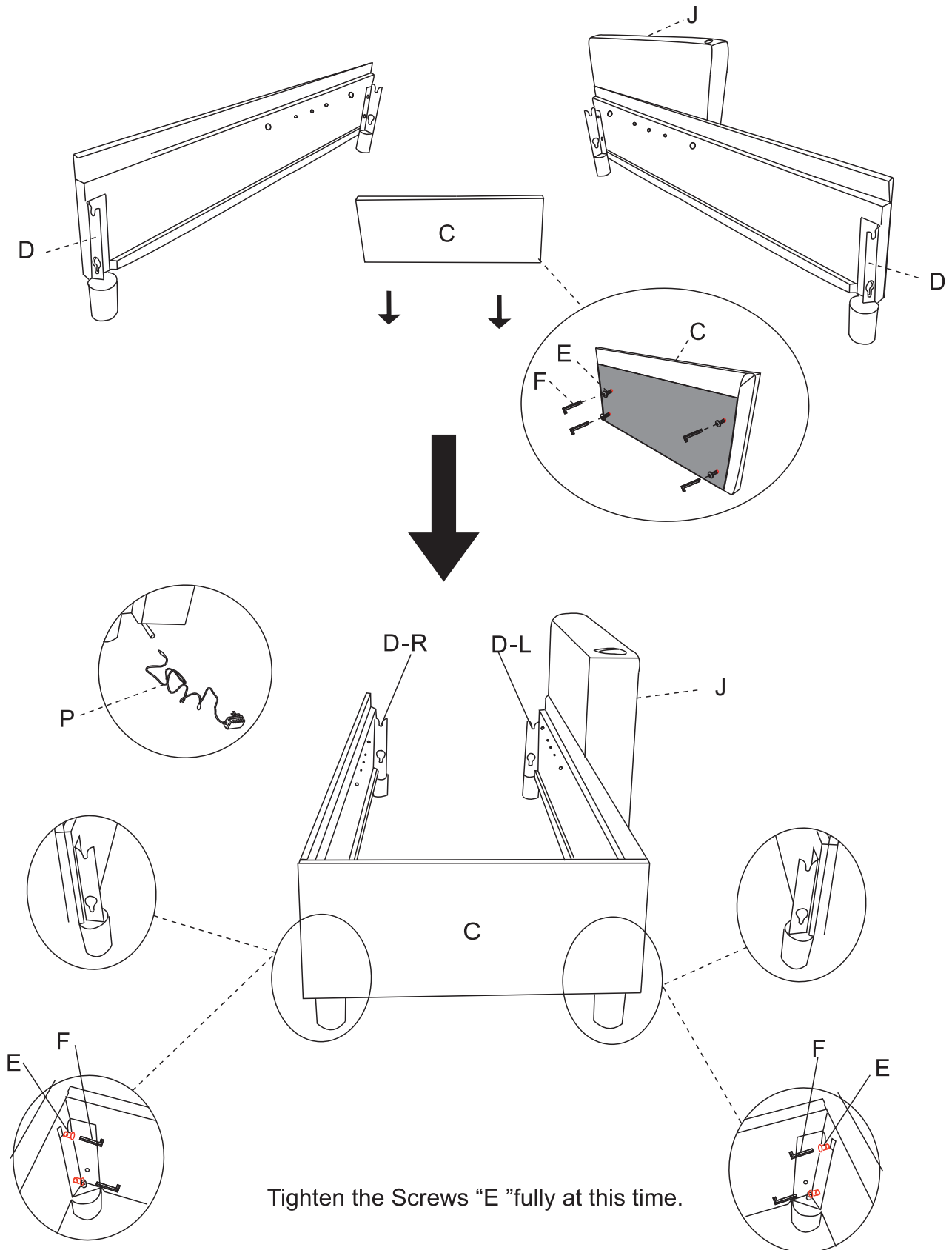

**STEP 3**

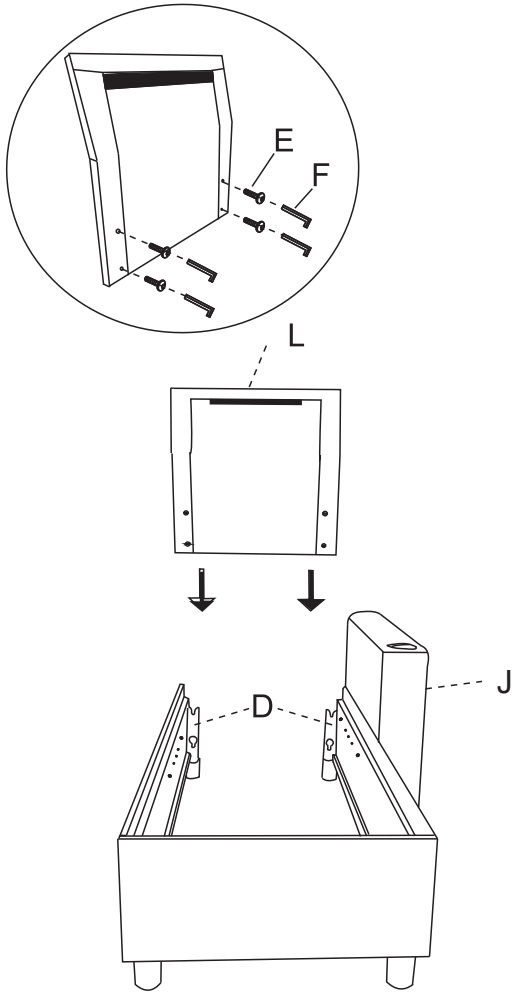

**STEP 4**

Insert the Screws "E" into Part "L" but do not tighten fully, then slide the Screws "E" into Connect Metal "D" to tighten the screws fully at that time

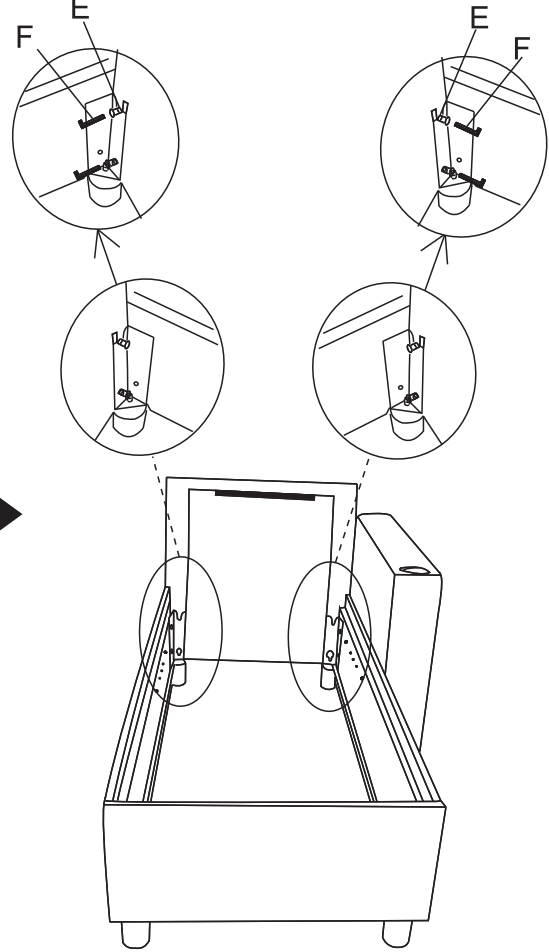

**STEP 5** Put the Chaise Seat Board "M" inside

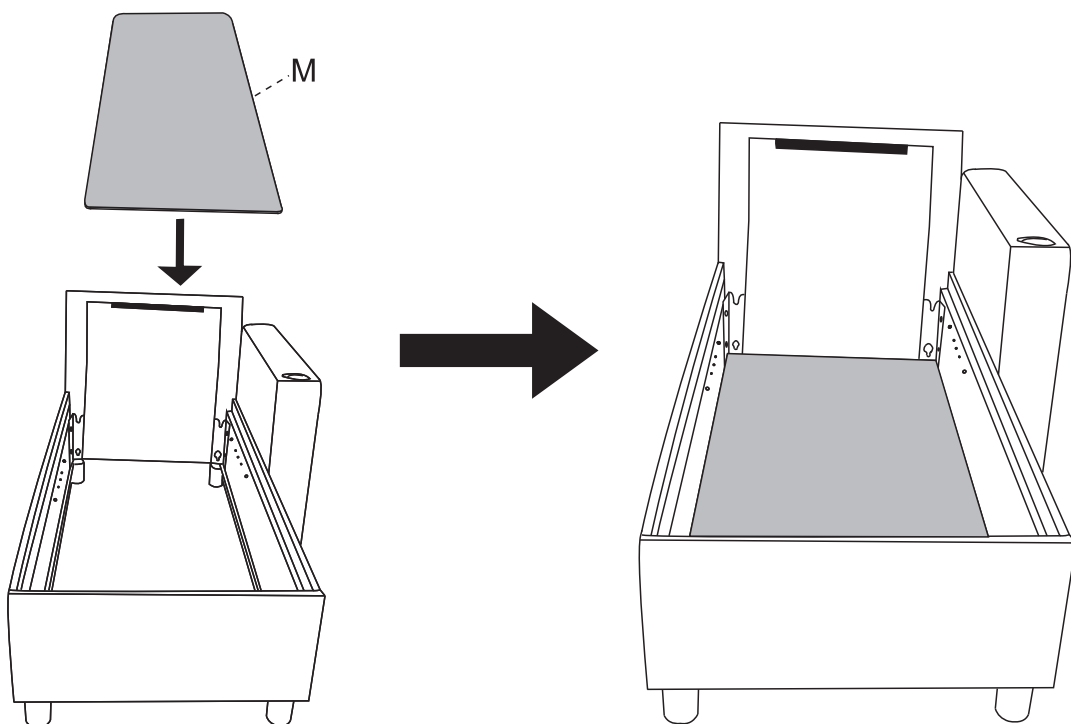

**STEP 6**

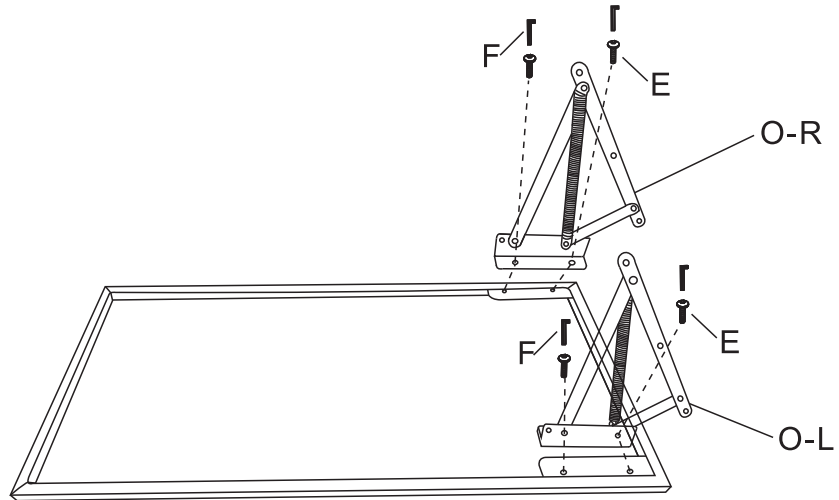

**STEP 7**

Insert 3 pieces Screws "E" separately into both side board

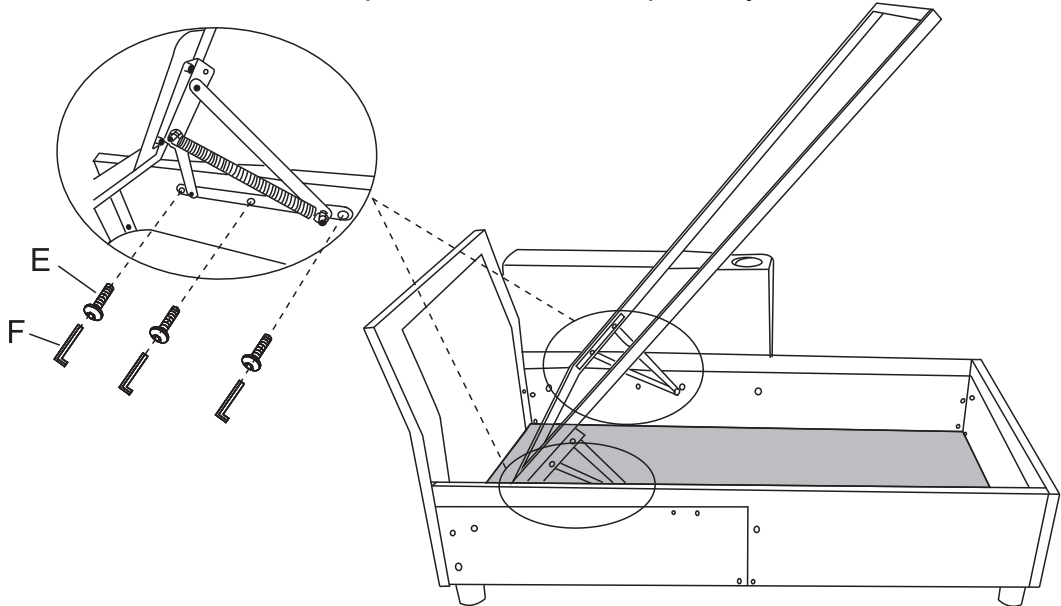

**STEP 8**

Push down the Panel N

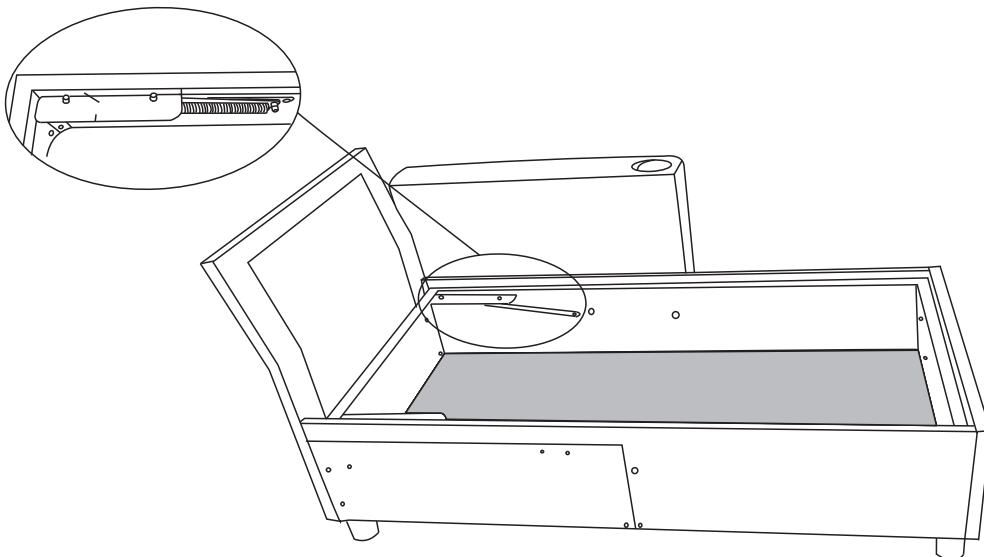

**STEP 9**

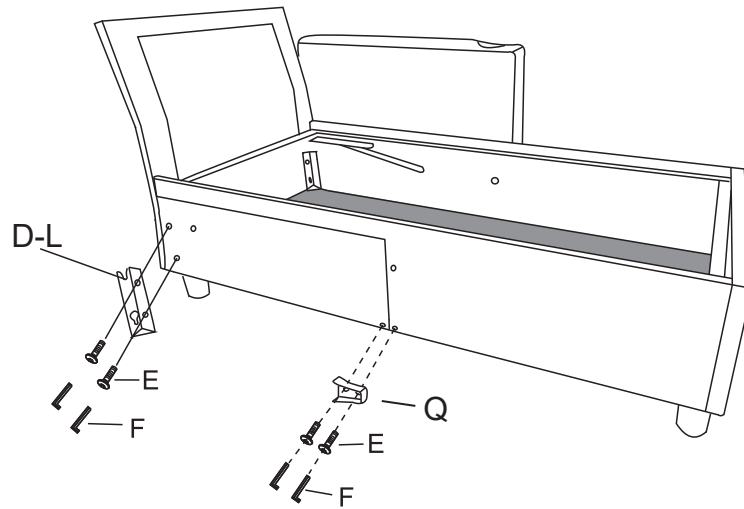

**STEP 10**

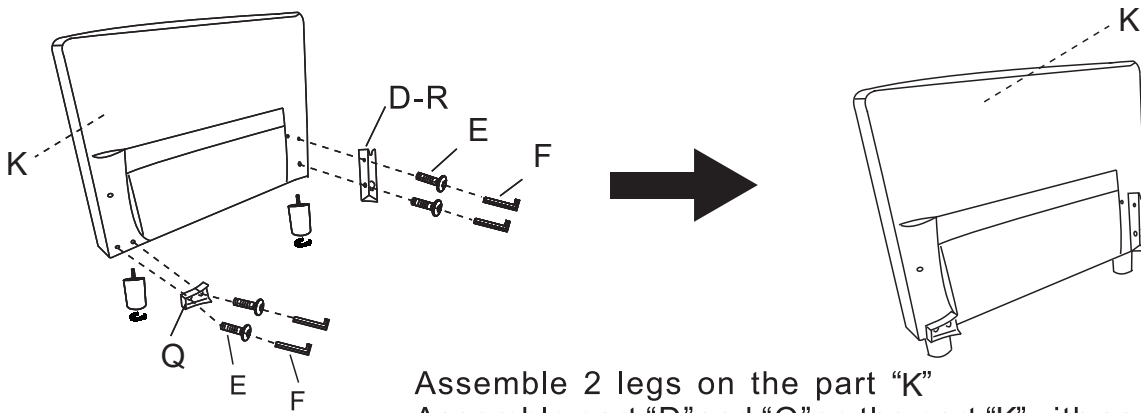

Assemble 2 legs on the part "K"  
Assemble part "D" and "Q" on the part "K" with screws "E"

**STEP 11**

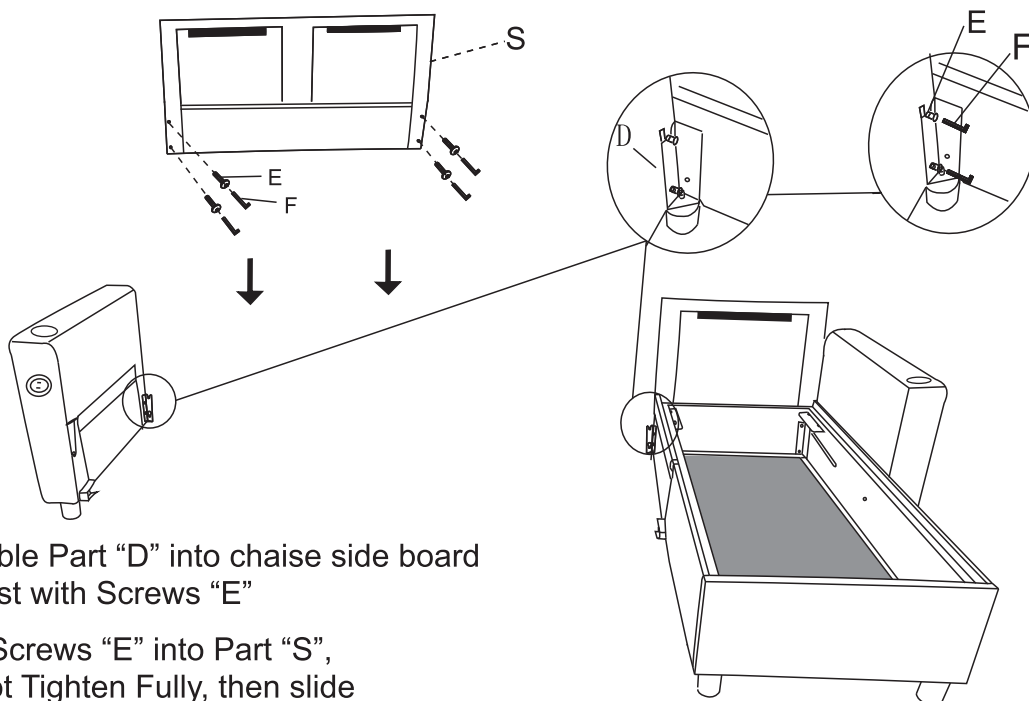

◆ Assemble Part "D" into chaise side board and armrest with Screws "E"

◆ Insert Screws "E" into Part "S", but Do Not Tighten Fully, then slide the Screws "E" into Connect Metal "D"

**Please tighten after next step finished**

STEP 12

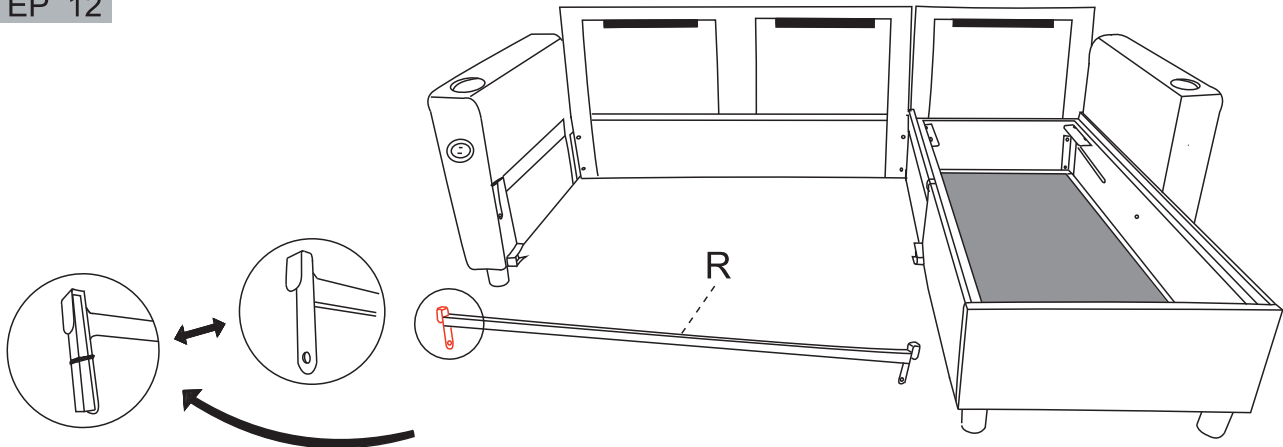

Remove small pieces protective wood while assembling

STEP 13

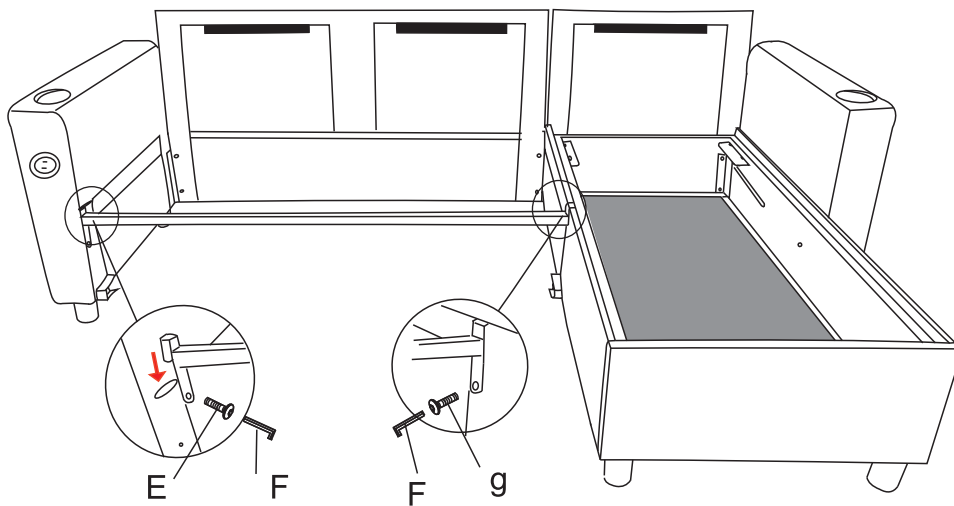

Insert this Part "R" into the hole on the armrest securing fabric and wood together. Then insert another side of Part "R" into the edge of the chaise side board. Then insert Screws "g" into the chaise side board. Then insert Screws "E" into armrest to fix "R". Finally tighten all Screws including "E" on Part "S".

STEP 14

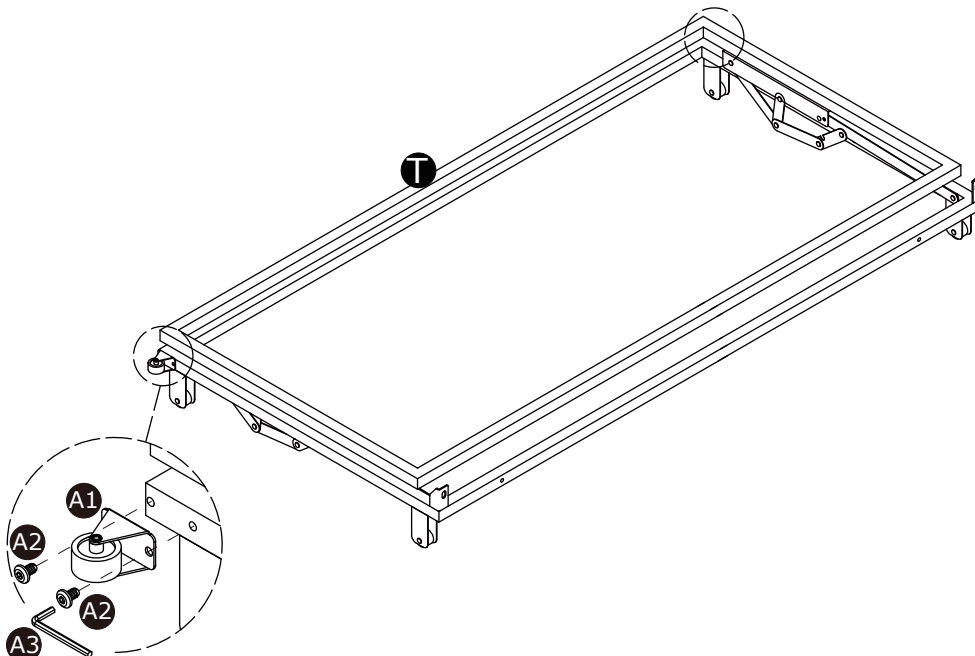

**STEP 15**

Tighten all screws fully after next step finished.

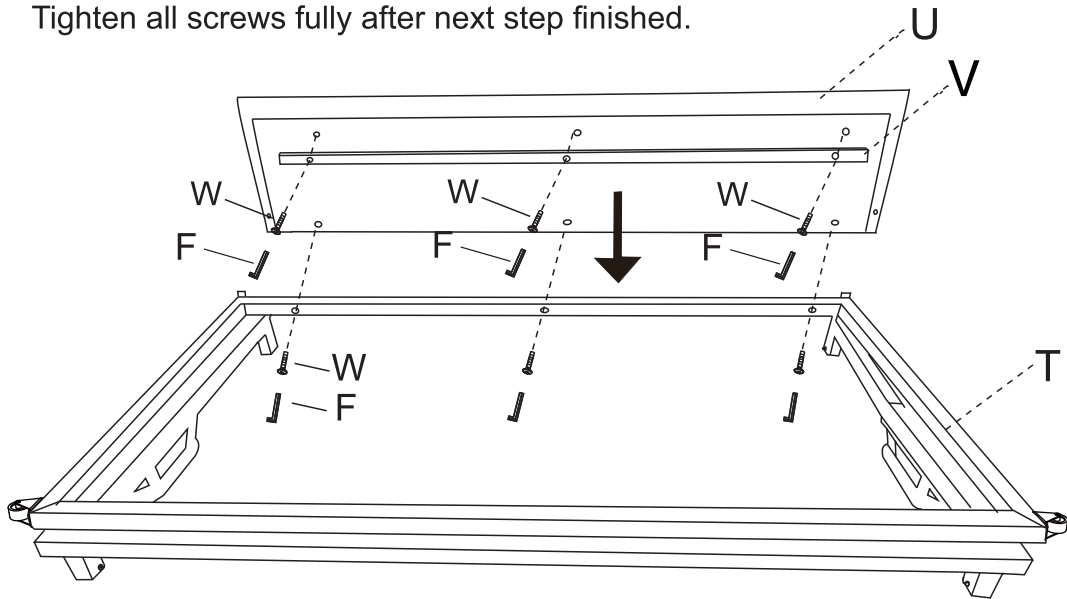

**STEP 16**

Tighten all screws including Screws "W" when you finish this step.

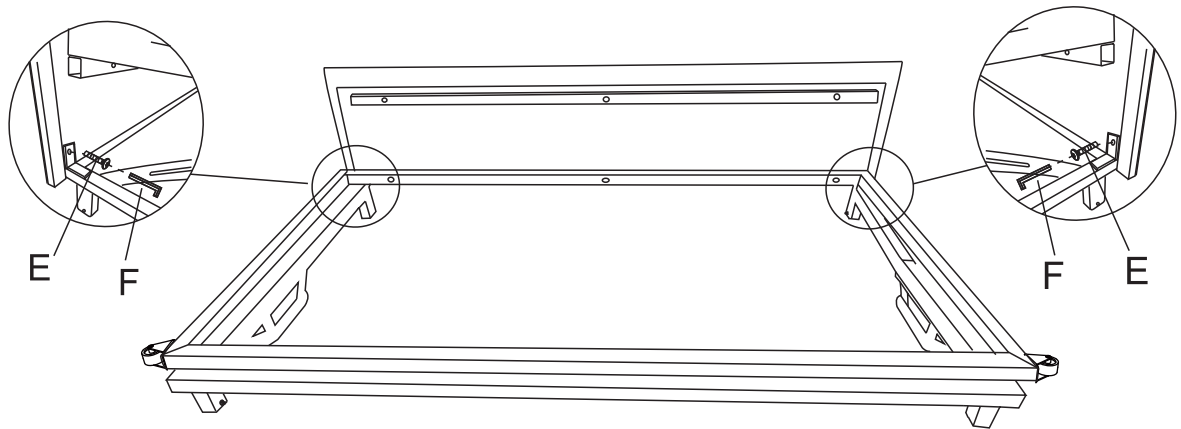

**STEP 17**

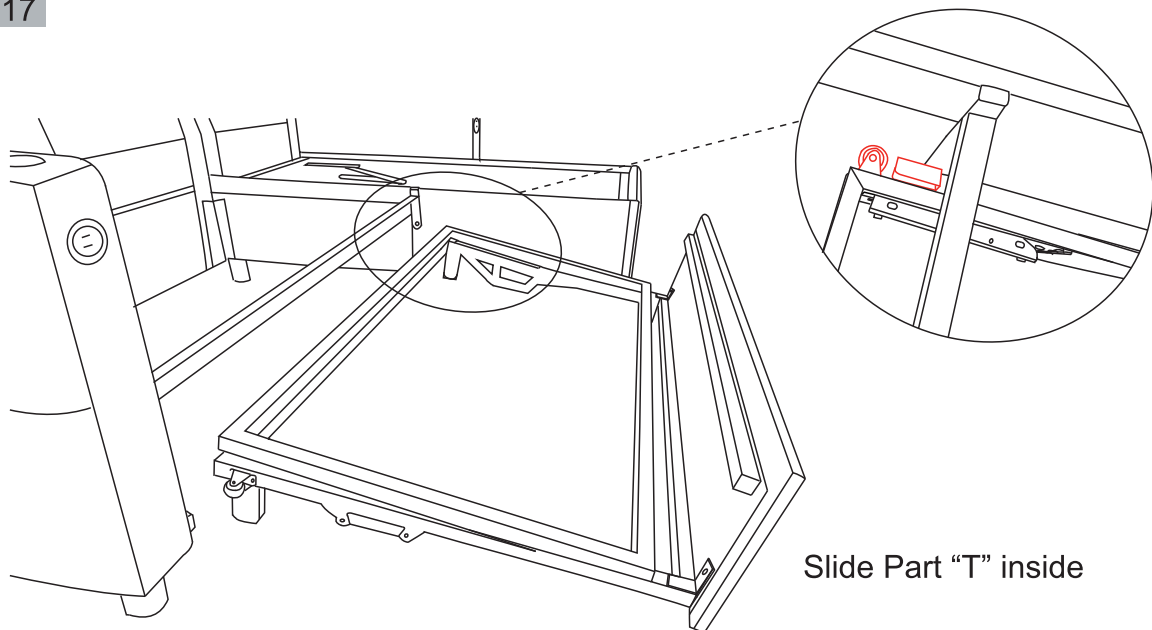

STEP 18

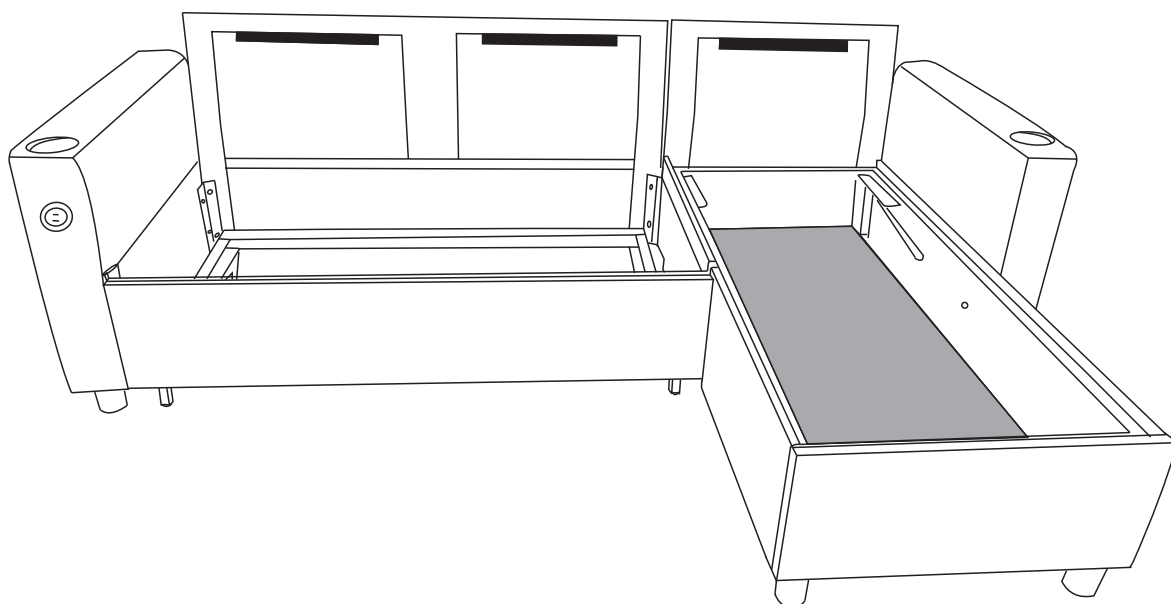

STEP 19

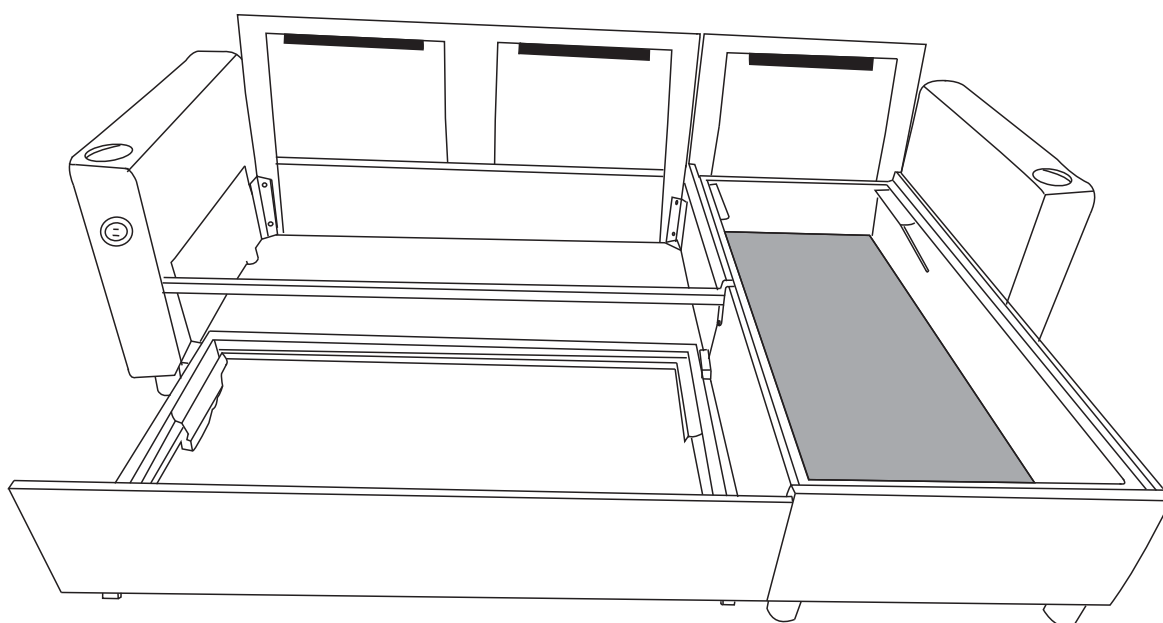

STEP 20

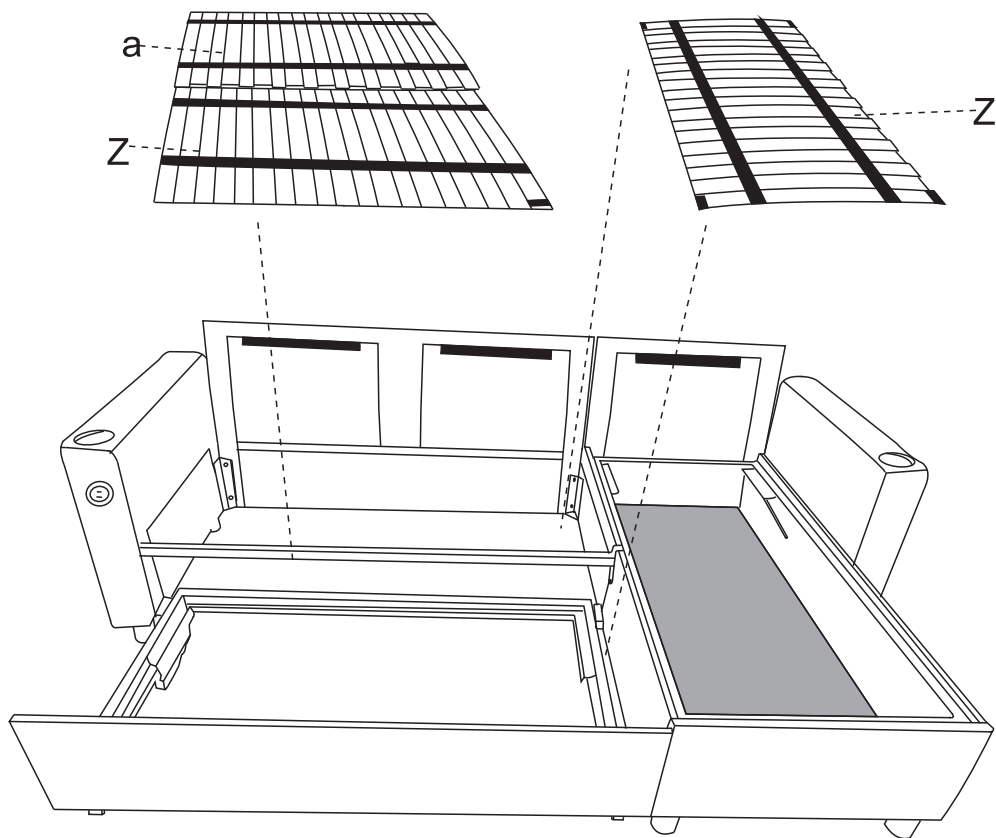

STEP 21

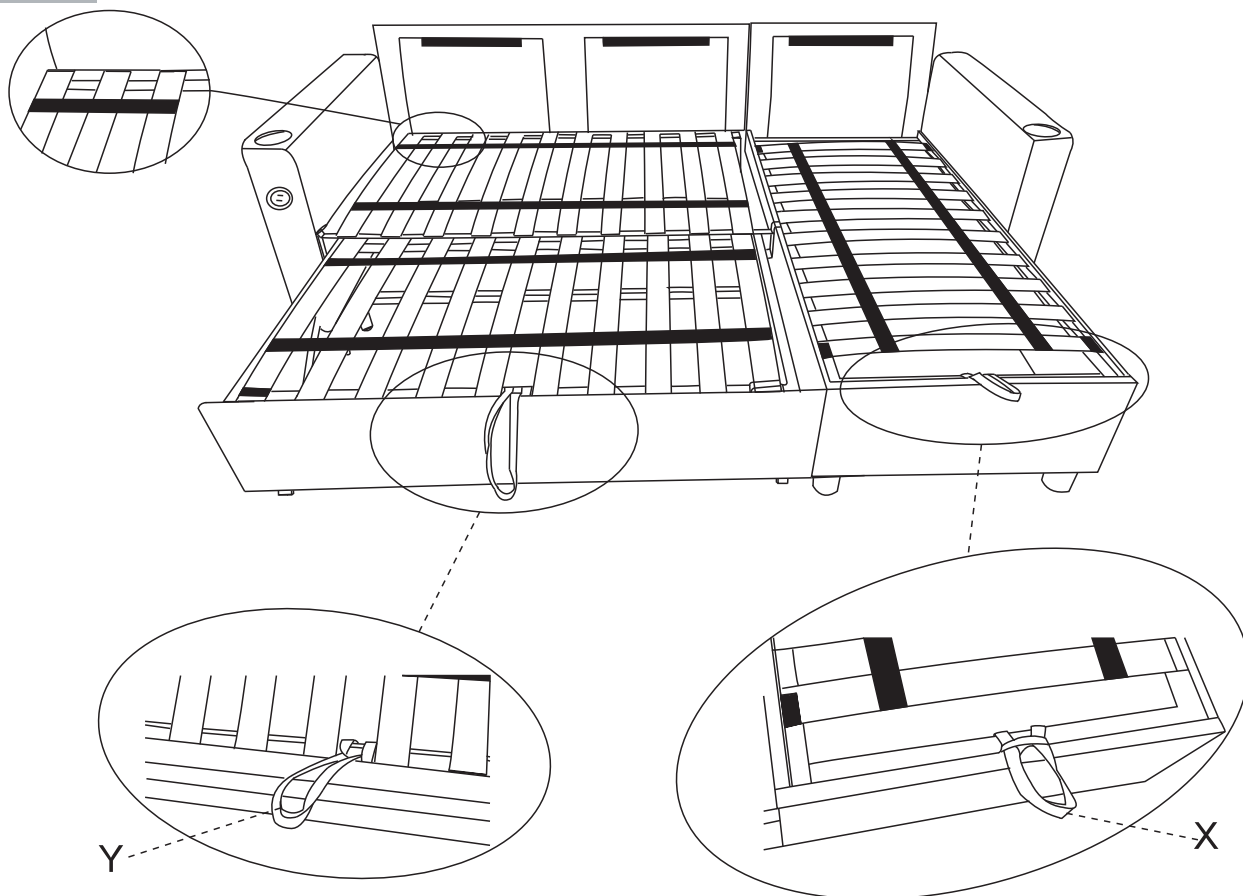

STEP 22

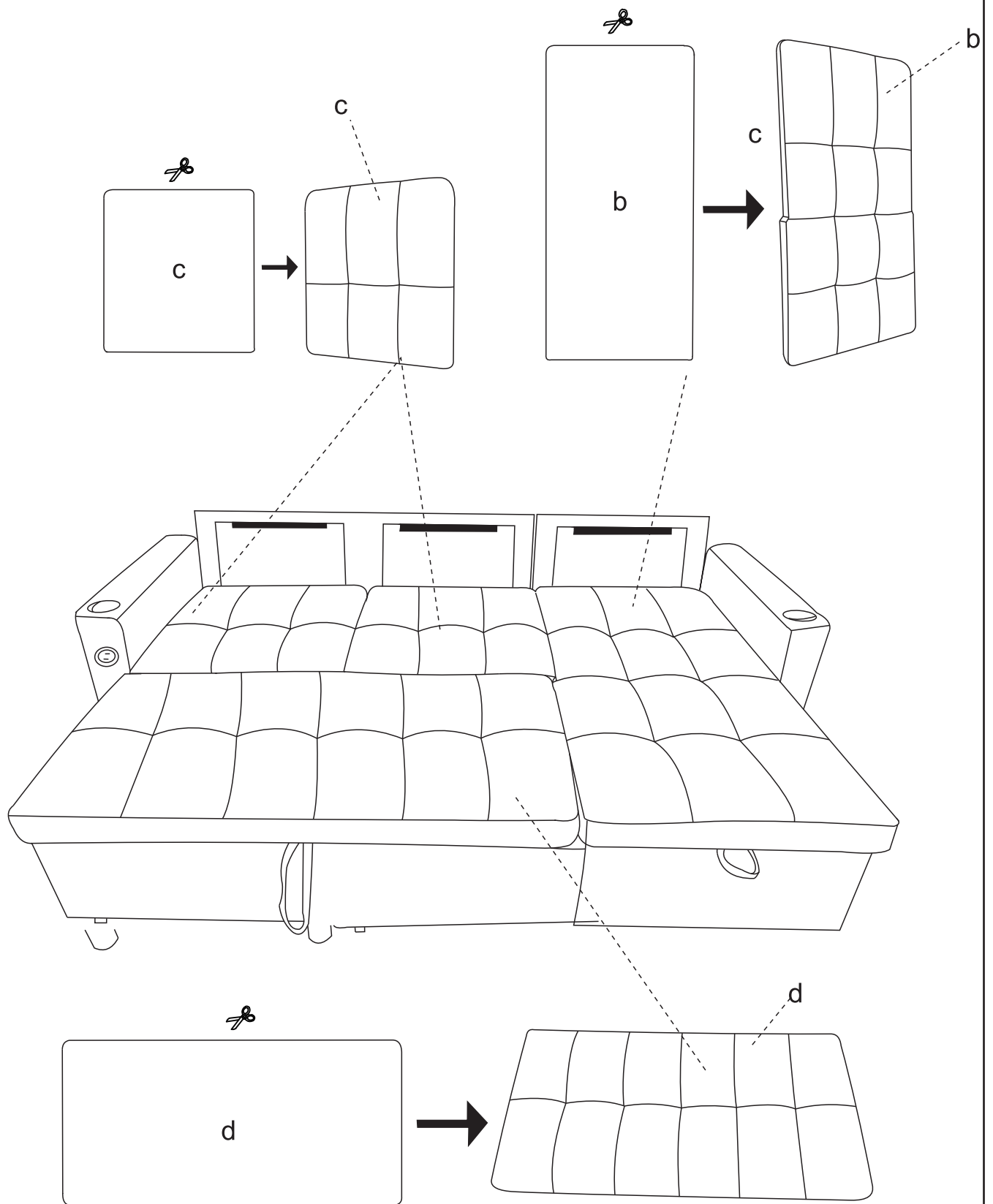

STEP 23

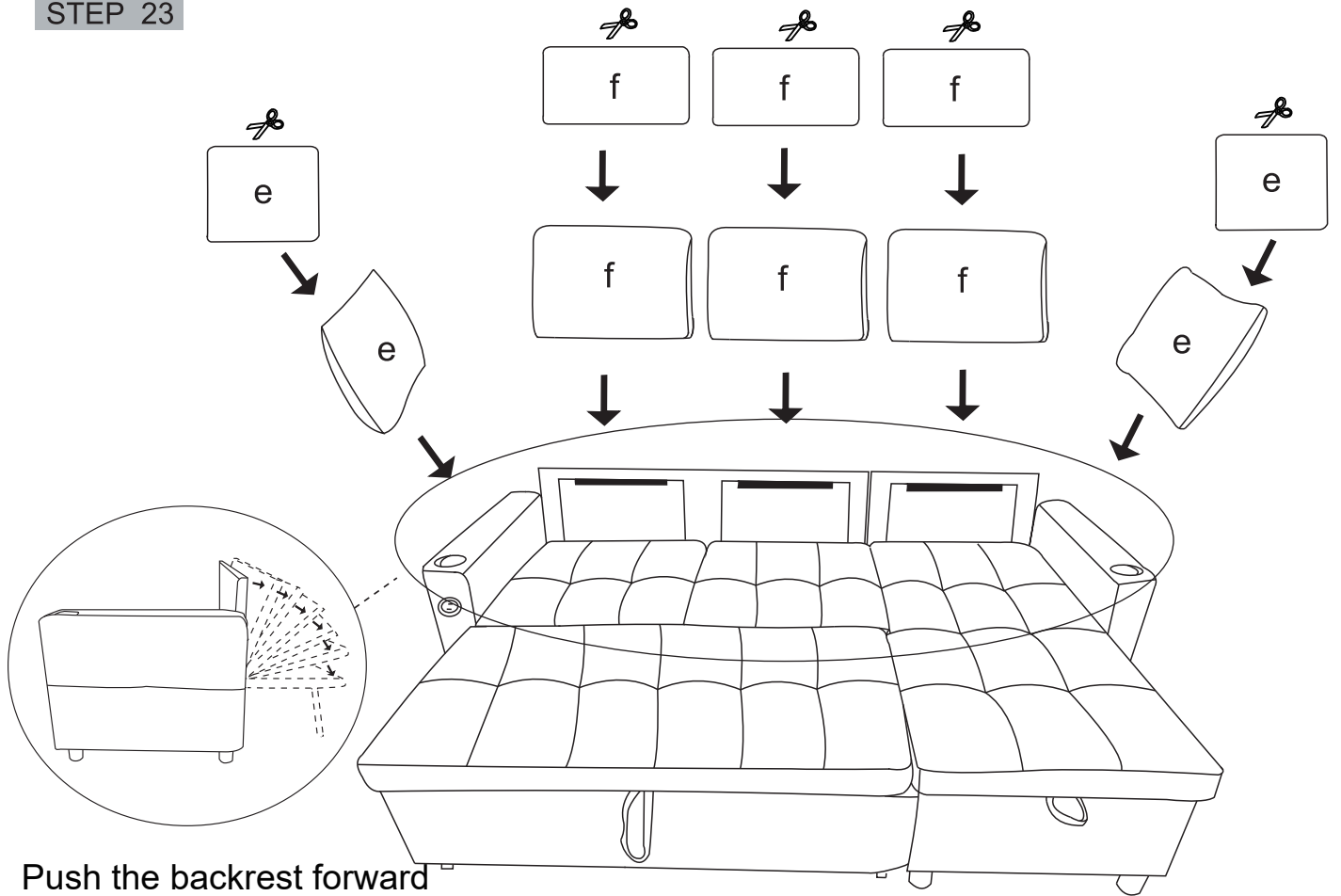

Push the backrest forward first then lay down the backrest **COMPLETELY** and then lift up the backrest to each angle as you need

STEP 24

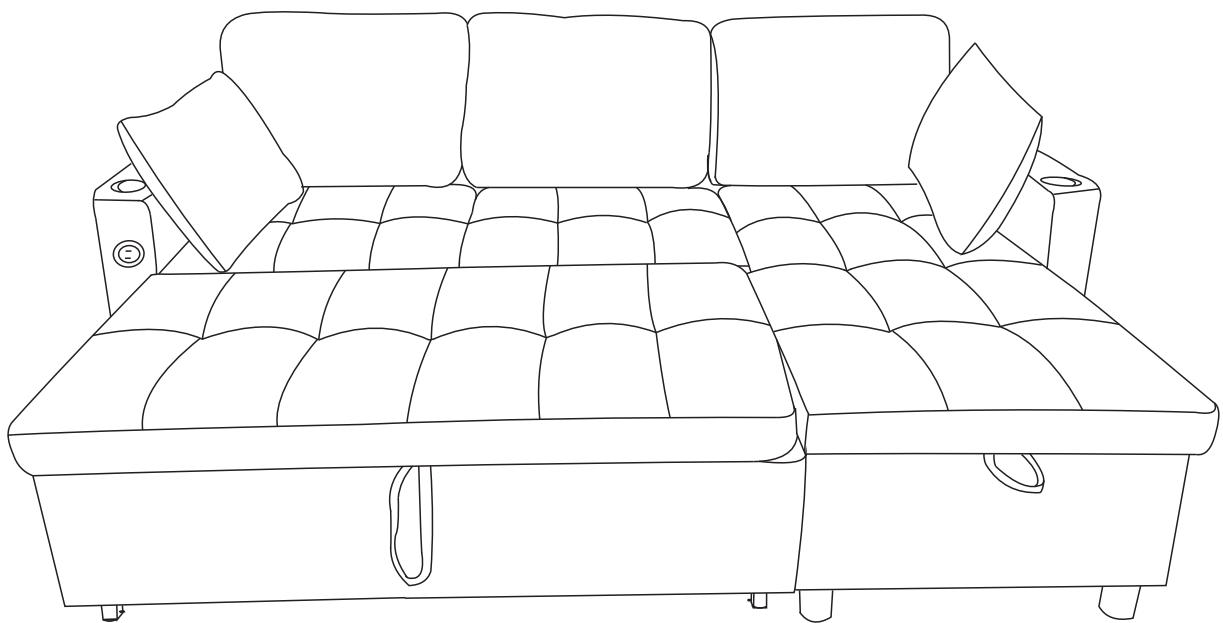

All the seat cushions and back cushions are compressed, before using, please allow 72H for the pillows and cushions to inflate totally