

ASSEMBLY INSTRUCTIONS

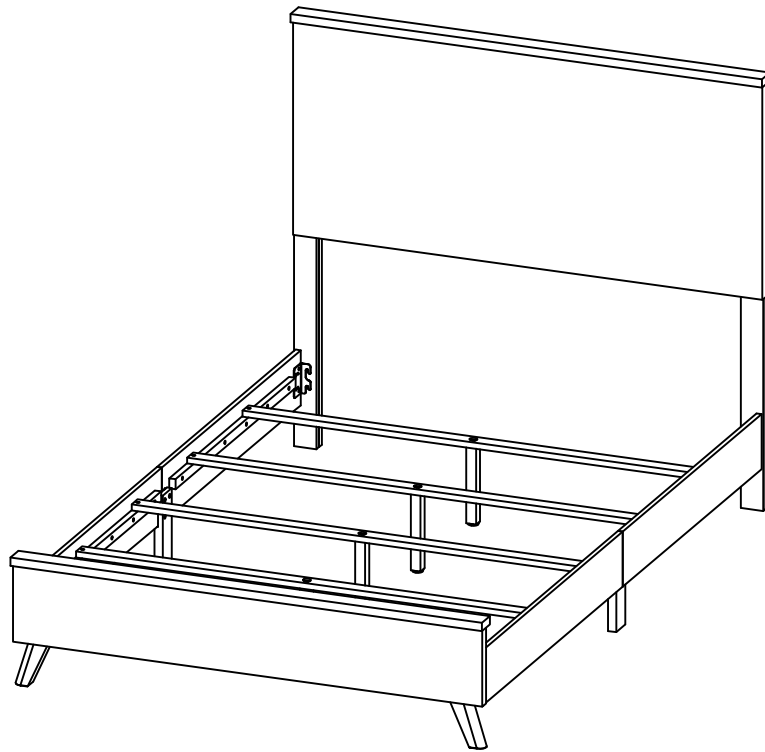

Queen Bed

ASSEMBLY INSTRUCTIONS

ASSEMBLY TIPS:

1. Remove hardware from box and sort by size.
2. Please check to see that all hardware and parts are present prior to start of assembly.
3. Please follow attached instructions in the same sequence as numbered to assure fast & easy assembly.



WARNING!



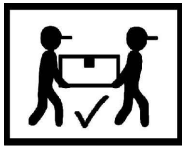





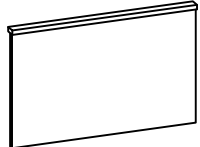

1. Don't attempt to repair or modify parts that are broken or defective. Please contact the store immediately.
2. This product is for home use only and not intended for commercial establishments.



ASSEMBLY TIME

30 MINUTES

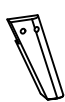
PARTS IDENTIFICATION

A HEADBOARD PANEL		1PC	G BED RAIL (WITH "G" LABEL)		2PCS
B LEFT HEADBOARD LEG (WITH "L" LABEL)		1PC	H BED RAIL (WITH "H" LABEL)		2PCS
C RIGHT HEADBOARD LEG (WITH "R" LABEL)		1PC	I BED RAIL SUPPORT		2PCS
D FOOTBOARD PANEL		1PC	J BED SLAT		4PCS
E LEFT FOOTBOARD LEG (WITH "L" LABEL)		1PC	K BED SLAT SUPPORT WITH LEVELER		4PCS
F RIGHT FOOTBOARD LEG (WITH "R" LABEL)		1PC			

ASSEMBLY INSTRUCTIONS

ASSEMBLY TIPS:

1. Remove hardware from box and sort by size.
2. Please check to see that all hardware and parts are present prior to start of assembly.
3. Please follow attached instructions in the same sequence as numbered to assure fast & easy assembly.



WARNING!

1. Don't attempt to repair or modify parts that are broken or defective. Please contact the store immediately.
2. This product is for home use only and not intended for commercial establishments.

HARDWARE IDENTIFICATION

1 **BOLT 1**
(M8 x 16MM - RBW)

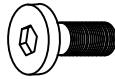

8PCS

2 **BOLT 2**
(M8 x 25MM - RBW)

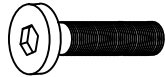

8PCS

3 **BOLT 3**
(M8 x 35MM - RBW)

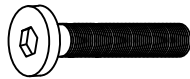

6PCS

4 **BIG LOCK WASHER**
(5/16" x 14Ø - RBW)

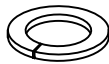

14PCS

5 **BIG FLAT WASHER**
(5/16" x 22Ø - RBW)

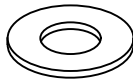

14PCS

6 **BOLT 4**
(M6 x 35MM - RBW)



4PCS

7 **SMALL LOCK WASHER**
(1/4" x 13Ø - RBW)



4PCS

8 **SMALL FLAT WASHER**
(1/4" x 19Ø - RBW)



4PCS

9 **FLAT HEAD SCREW**
(M4 x 32MM - RBW)



8PCS

10 **SMALL ALLEN WRENCH**
(M4 x 60MM - BLK)



1PC

11 **BIG ALLEN WRENCH**
(M5 x 68MM - BLK)



1PC

NOTE:

Phillips head screw driver is required in the assembly process; however, manufacturer does not provided this item.

ASSEMBLY INSTRUCTIONS

STEP 1

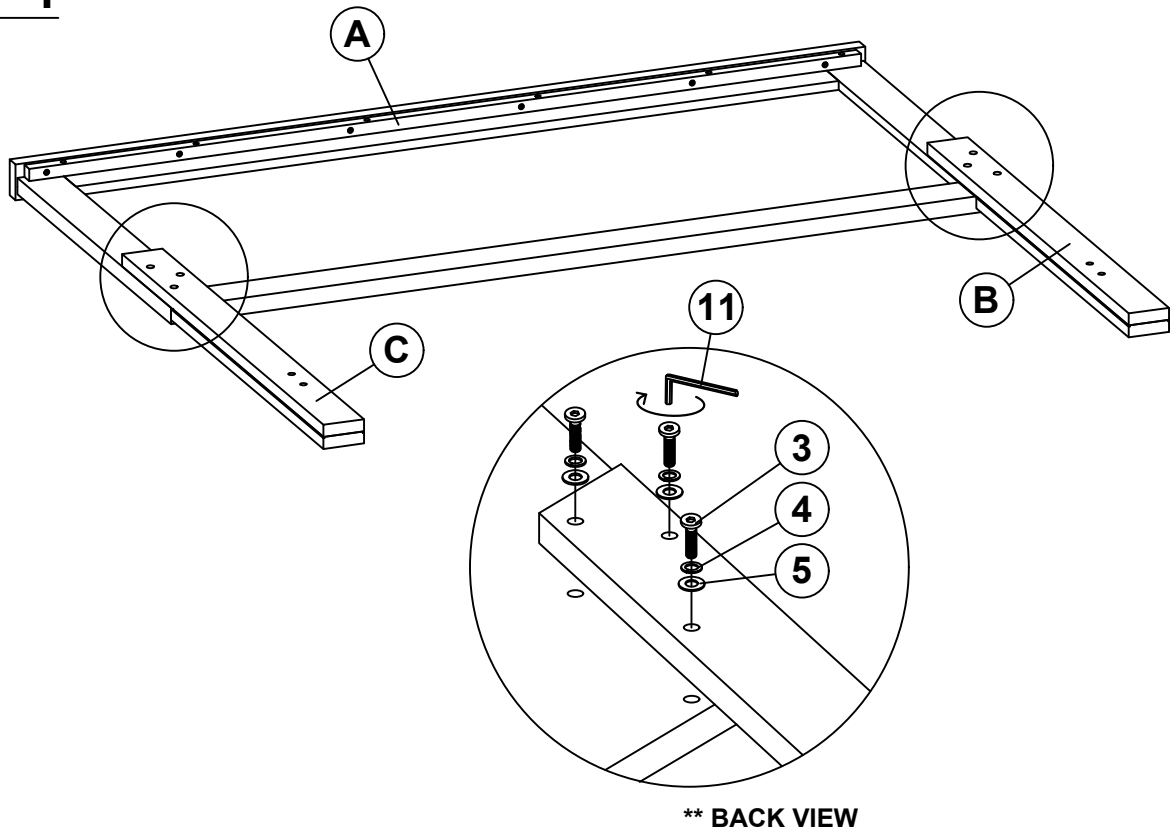

STEP 2

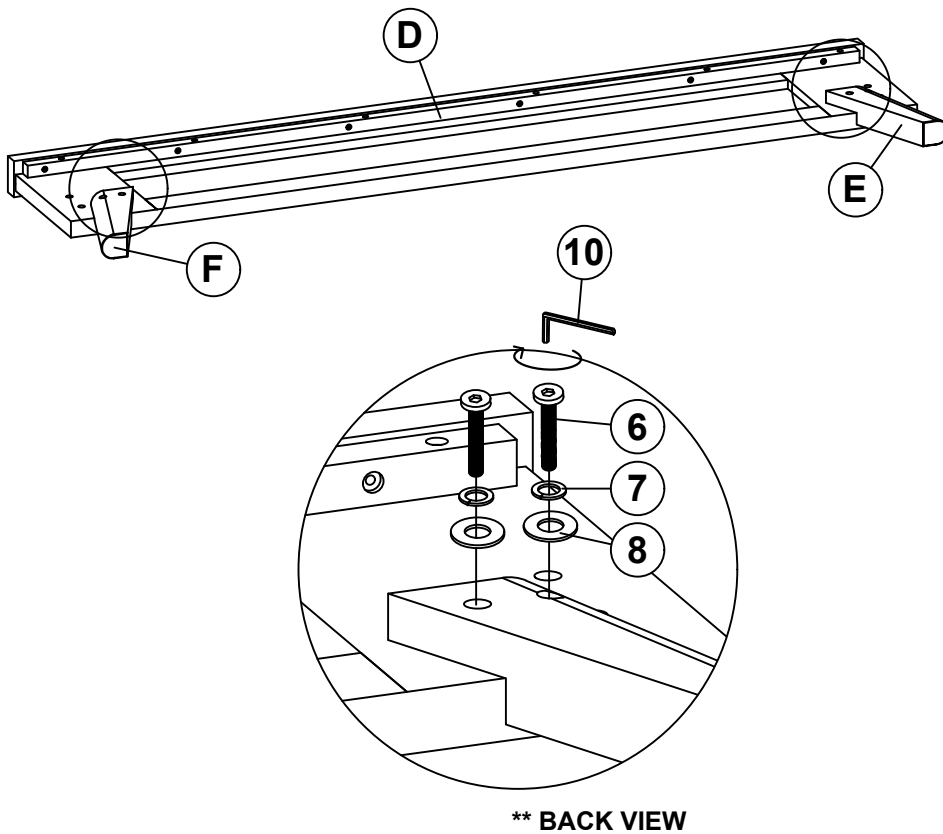

ASSEMBLY INSTRUCTIONS

STEP 3

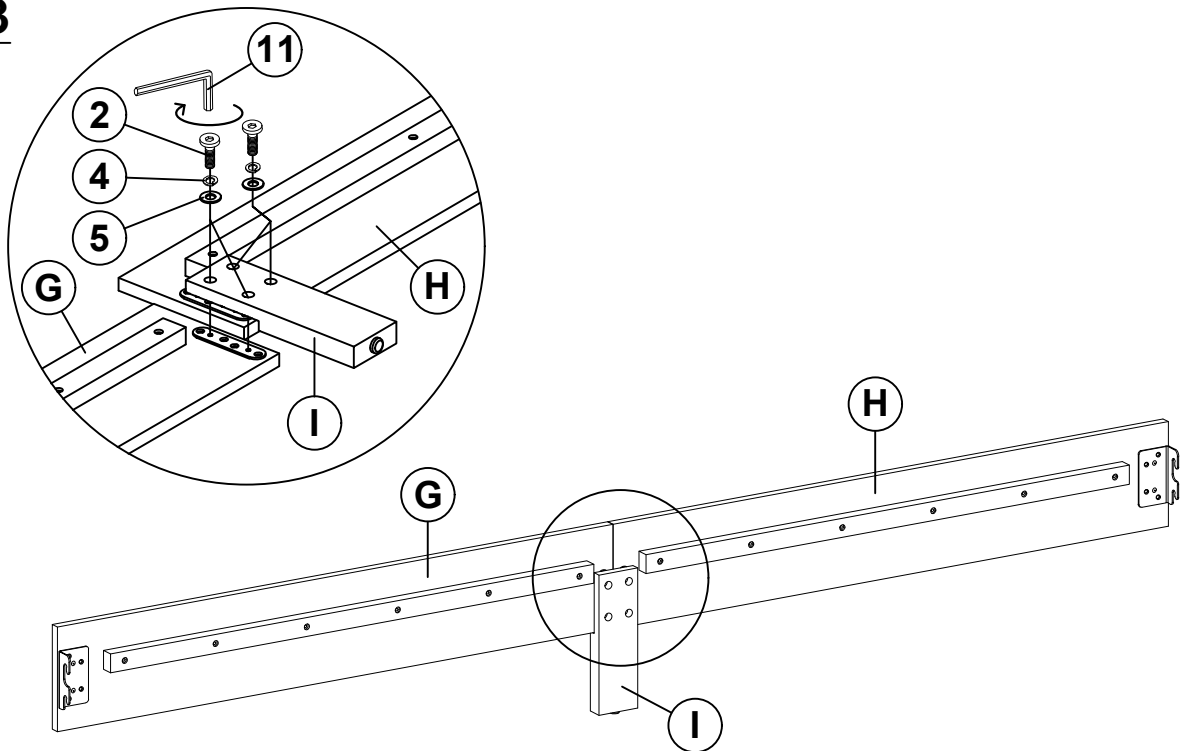

STEP 4

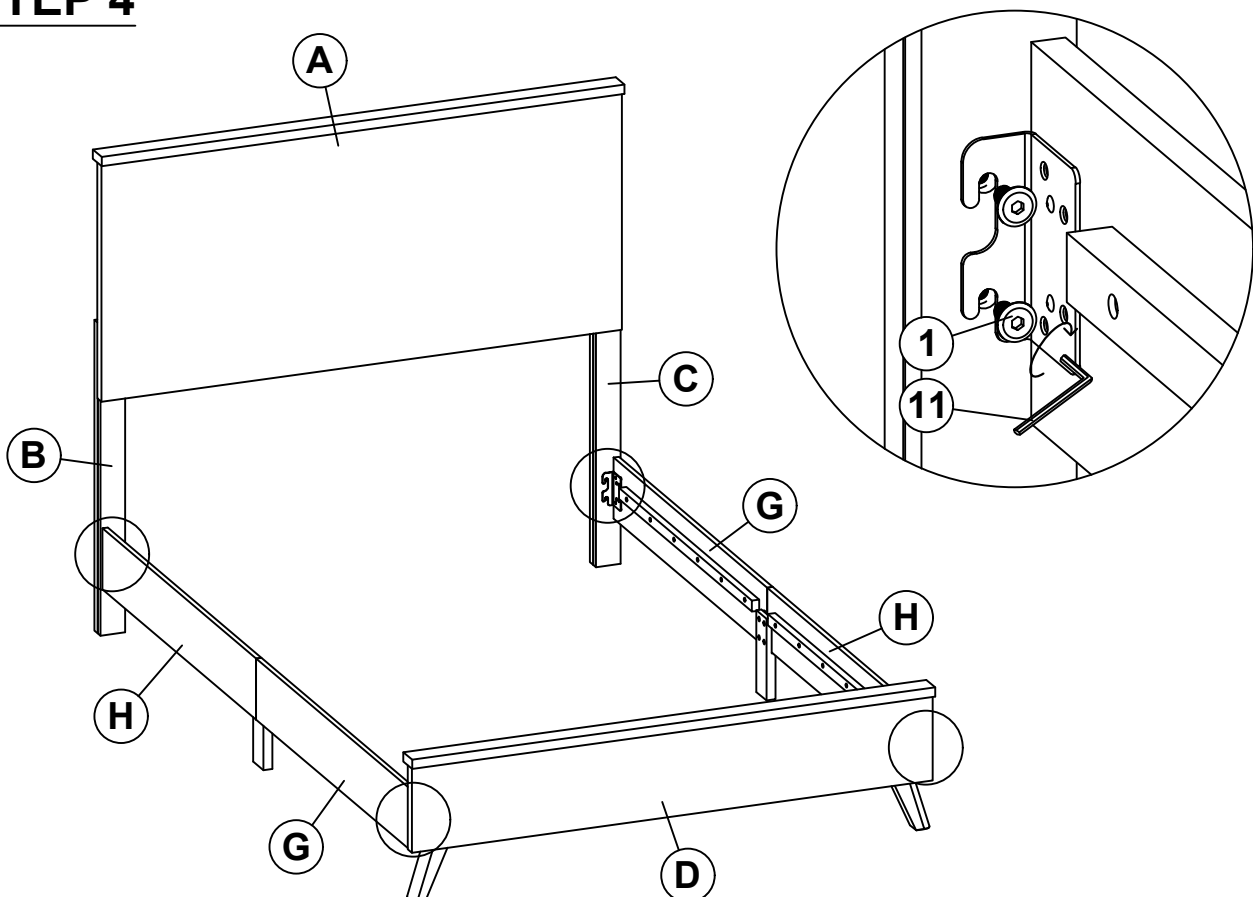

ASSEMBLY INSTRUCTIONS

STEP 5

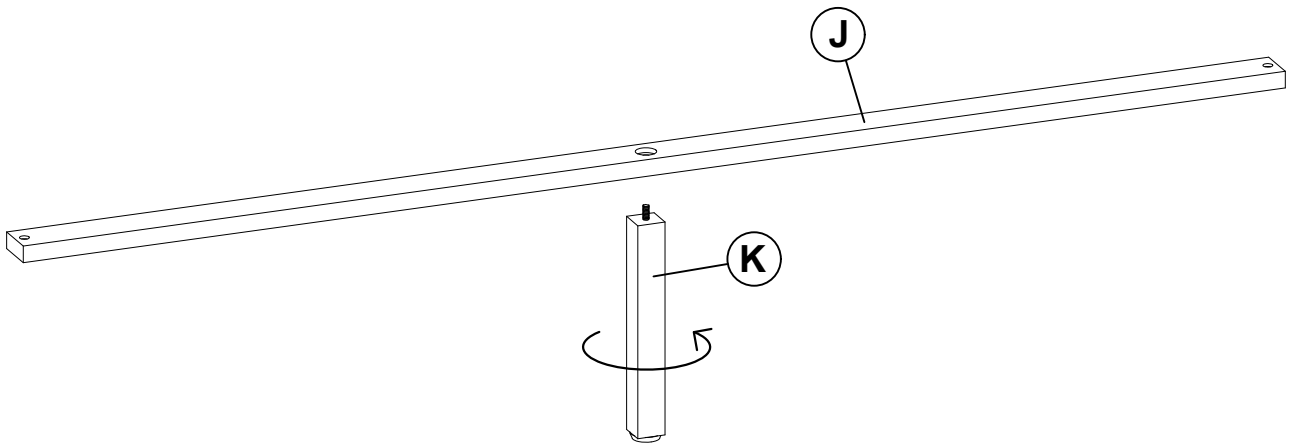

STEP 6 **COMPLETE**

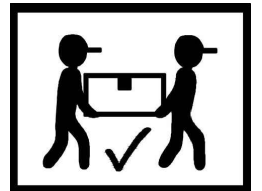
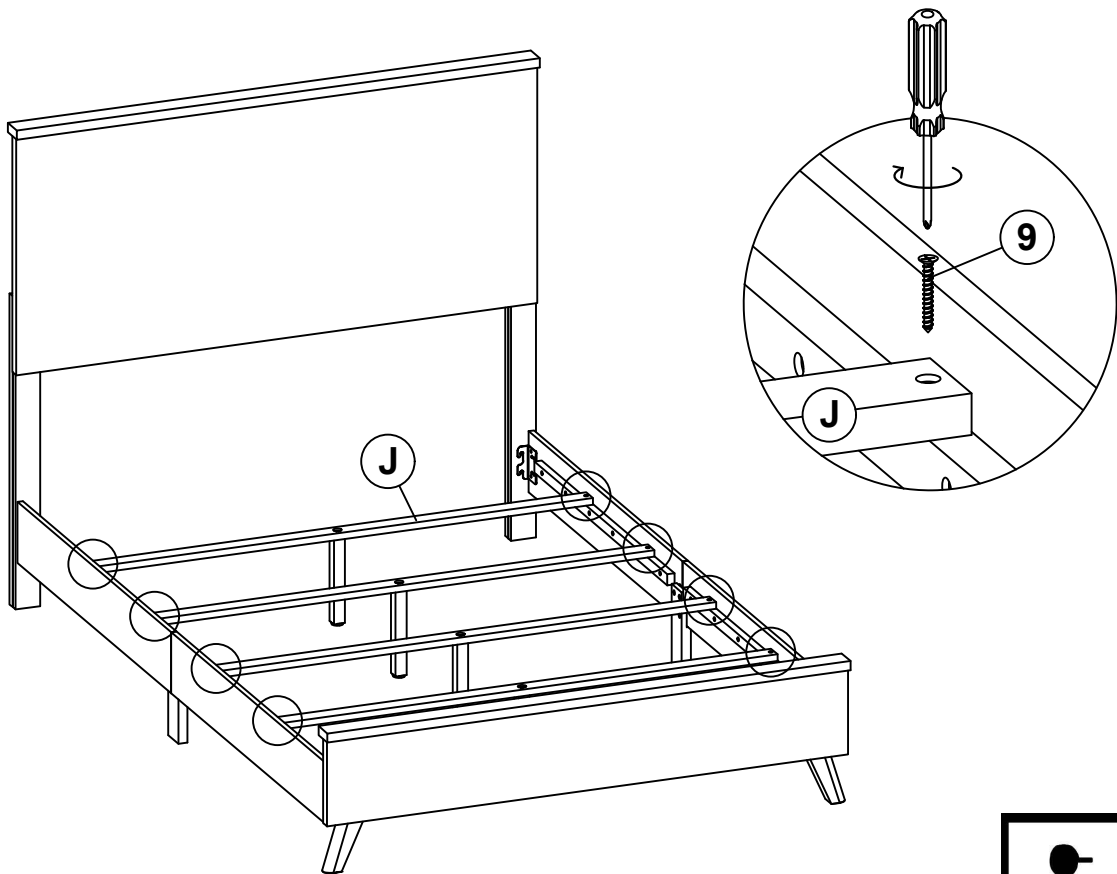

ITEM: **225001Q**



Inner Size : 60.75"W X 81.00"D

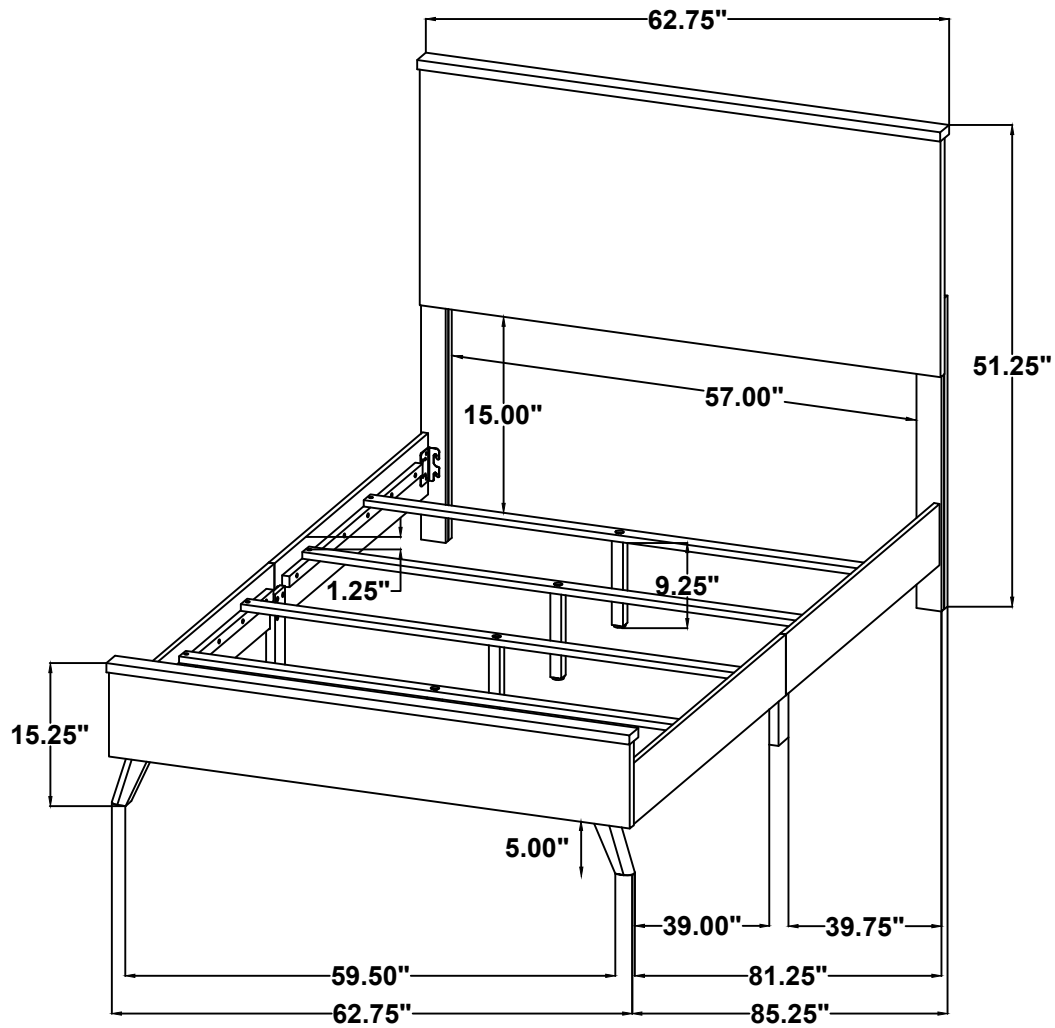

Note : Dimension tolerance $\pm 5\%$