

I870101035A1/A2

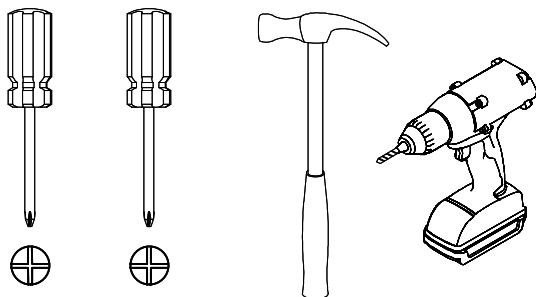

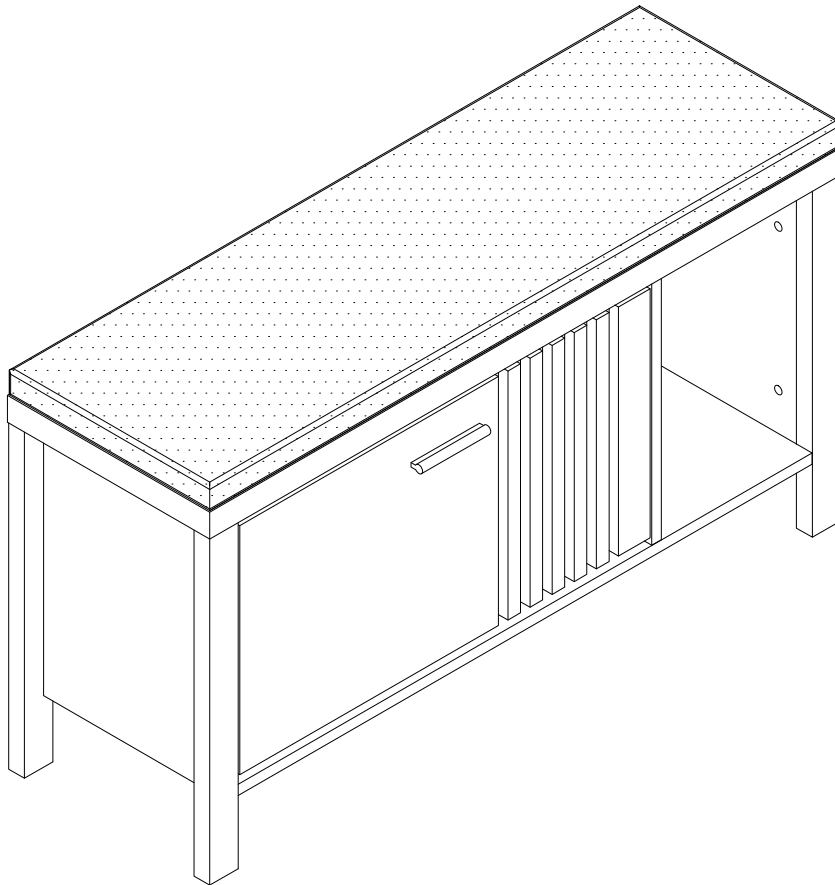

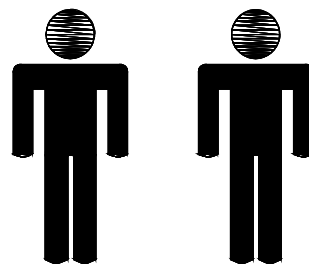



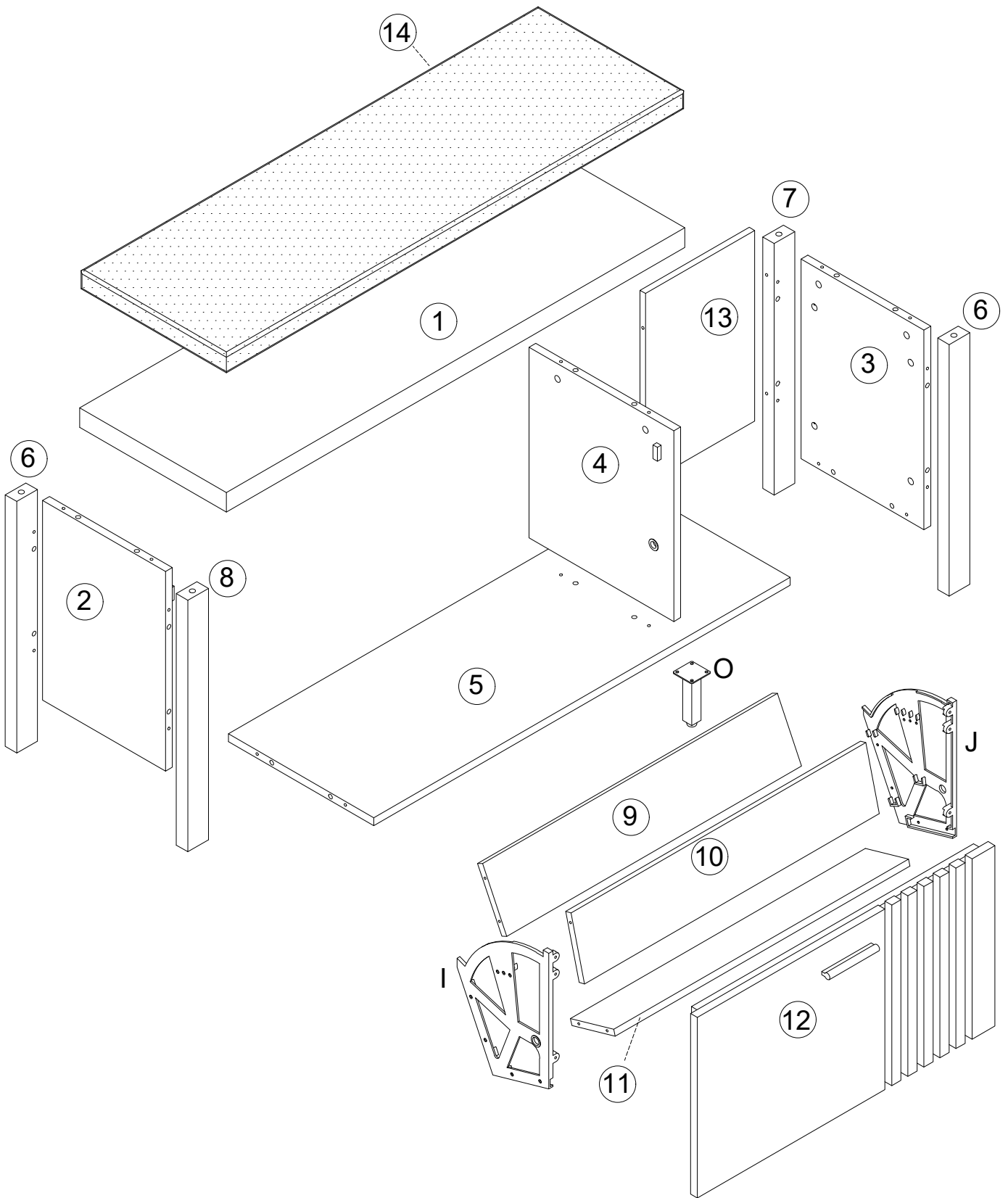

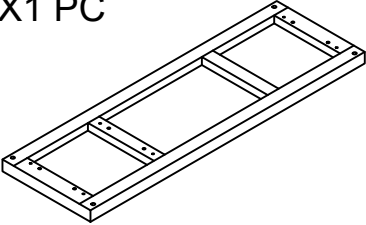
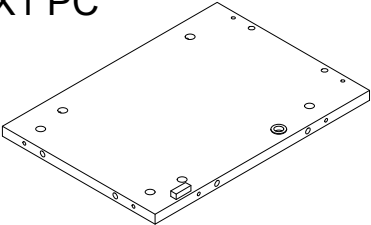
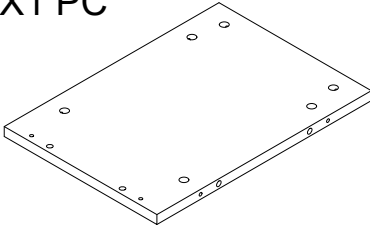
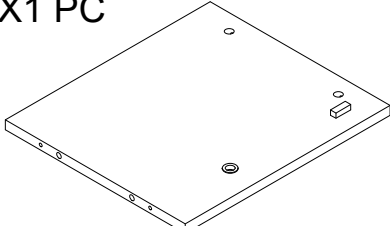
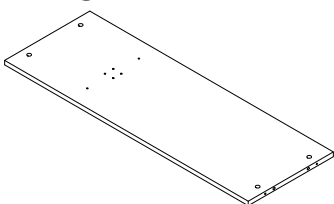
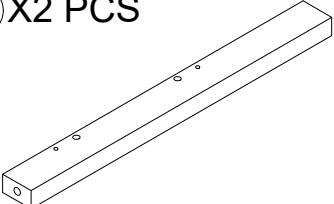
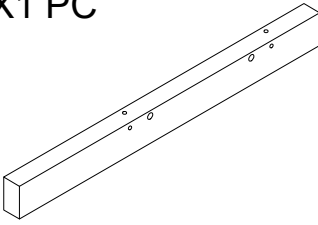
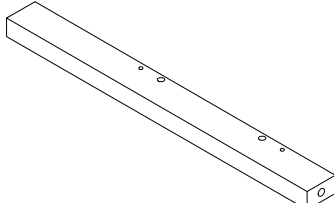
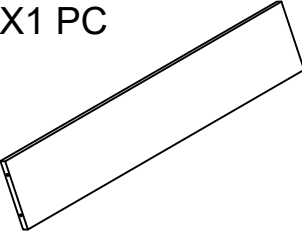
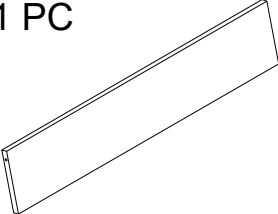
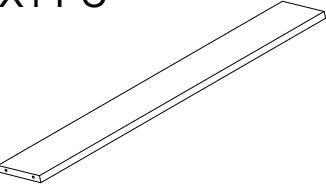
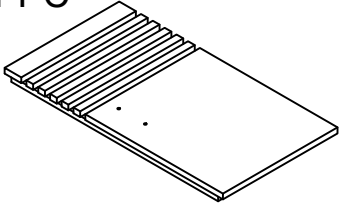
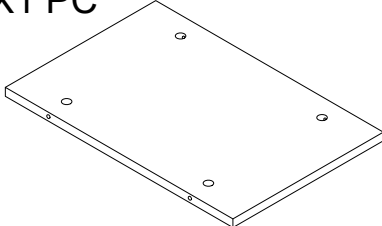
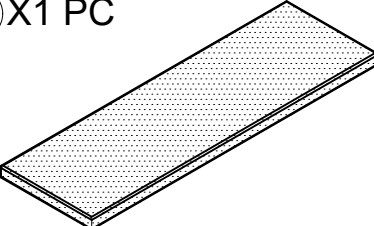
**Tools required
(not included)**

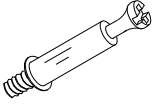

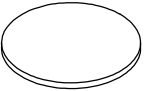
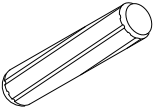
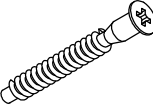
2 people for assembly

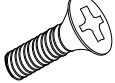

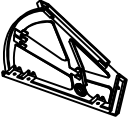
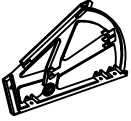
<p>① X1 PC</p> 	<p>② X1 PC</p> 	<p>③ X1 PC</p> 
<p>④ X1 PC</p> 	<p>⑤ X1 PC</p> 	<p>⑥ X2 PCS</p> 
<p>⑦ X1 PC</p> 	<p>⑧ X1 PC</p> 	<p>⑨ X1 PC</p> 
<p>⑩ X1 PC</p> 	<p>⑪ X1 PC</p> 	<p>⑫ X1 PC</p> 
<p>⑬ X1 PC</p> 	<p>⑭ X1 PC</p> 	

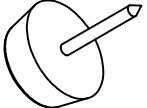
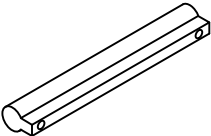
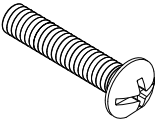
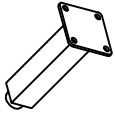
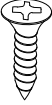
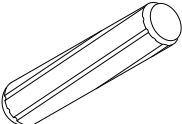
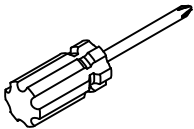
<p>A</p>  <p>Ø6*35mm 22+2 PCS</p>	<p>B</p>  <p>Ø15*9mm 22+2 PCS</p>	<p>C</p>  <p>Ø20mm 28+2 PCS</p>	<p>D</p>  <p>Ø6*30mm 20+2 PCS</p>
<p>E</p>  <p>Ø5*40mm 2+1 PC</p>	<p>F</p>  <p>Ø18*12mm 2 PCS</p>	<p>G</p>  <p>Ø7*M4*8mm 2+1 PC</p>	<p>H</p>  <p>Ø3.5*16mm 10+1 PC</p>
<p>I</p>  <p>291*197*23mm 1 PC</p>	<p>J</p>  <p>291*197*23mm 1 PC</p>	<p>K</p>  <p>Ø3.5*16mm 6+1 PC</p>	<p>L</p>  <p>Ø12*5mm 4+1 PC</p>
<p>M</p>  <p>108*12*18mm 1 PC</p>	<p>N</p>  <p>M4*18mm 2+1 PC</p>	<p>O</p>  <p>42*42*98mm 1 PC</p>	<p>P</p>  <p>Ø3.5*12mm 4+1 PC</p>
<p>Q</p>  <p>Ø10*40mm 4+1 PC</p>	 <p>1 PC</p>		

Instructions For Fastening CAM-BOLT and CAM-LOCK

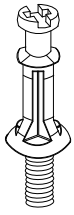

CAM-BOLT

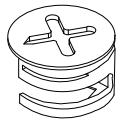

CAM-LOCK

Tools Required



INSERTING AND TIGHTENING CAM-BOLT

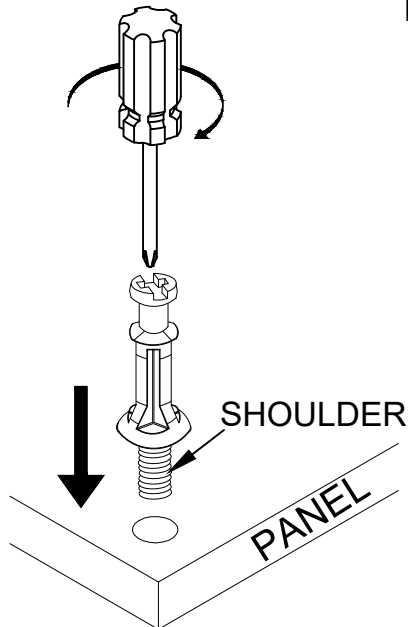

Place Cam-bolt on pre-drilled hole and screw in vertically

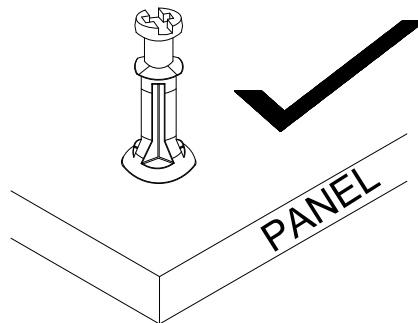

Shoulder is flushed (on the same level) with the panel.

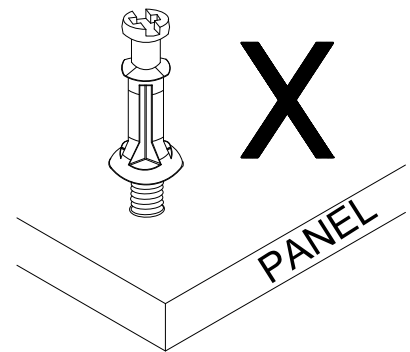

Shoulder is above the panel.

Place Cam-bolt on the designated pre-drilled holes on the panel. Use a Phillips Screwdriver to screw-in Cam-bolt vertically until shoulder is flushed (on the same level) with panel.

INSERTING CAM-LOCK

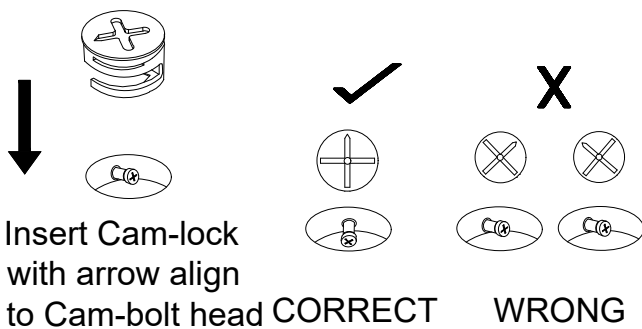

Insert Cam-lock with arrow align to Cam-bolt head **CORRECT**

WRONG

TIGHTENING CAM-LOCK

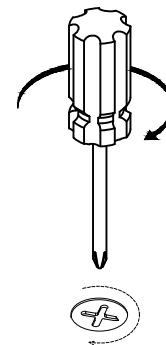

Use a Flat-head Screwdriver to turn Camlock clockwise so it locks onto the head of the Cam-bolt. Turn until it is snug (about 3/4ths of a turn) -- over-tightening could damage Cam-lock or/and Cam-bolt.

Align the arrow on the Cam-lock to the Cam-bolt head and insert the Cam-lock. Ensure Cam-lock is fully inserted.

1

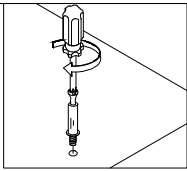

A x12

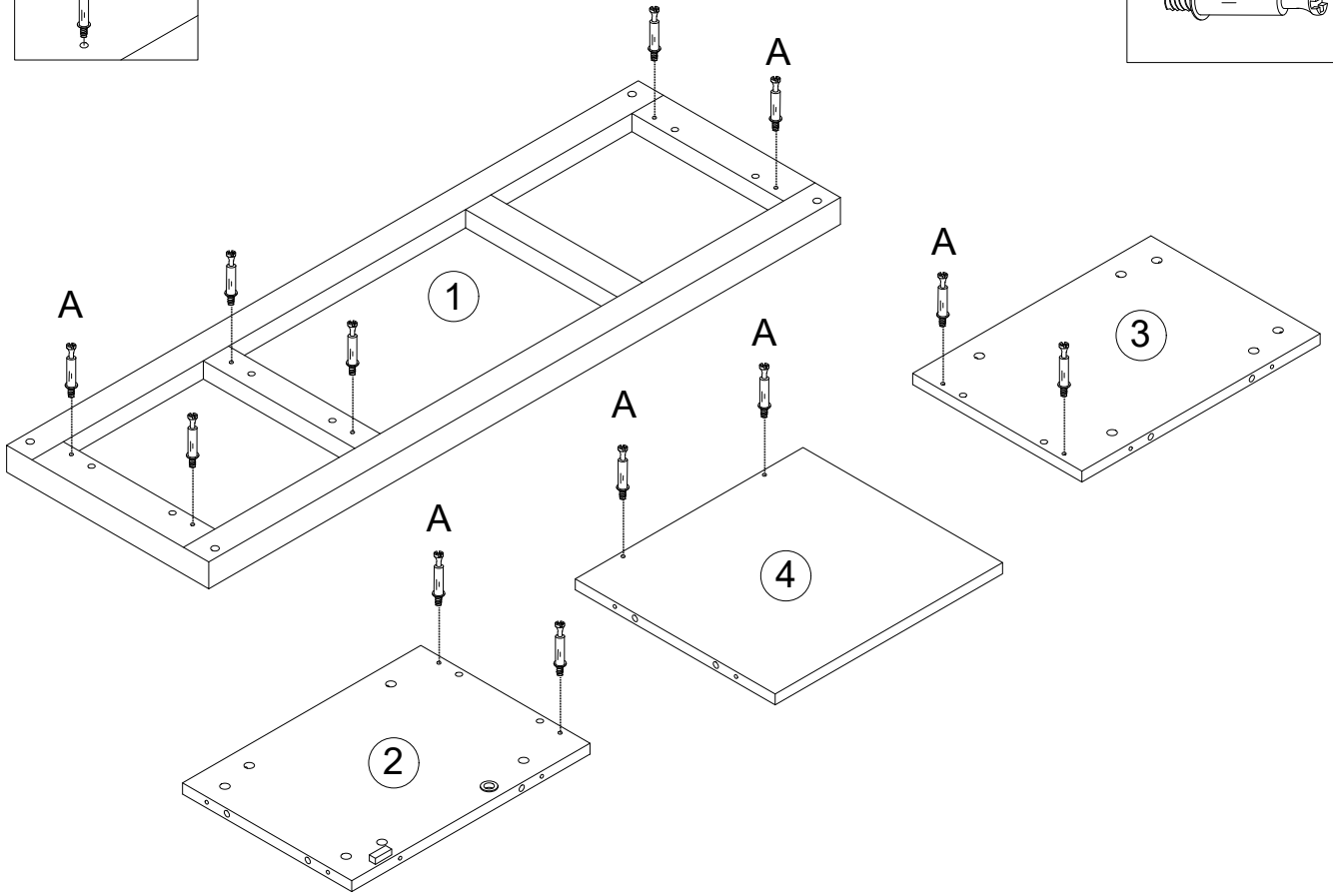
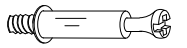

2

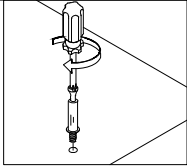

A x10

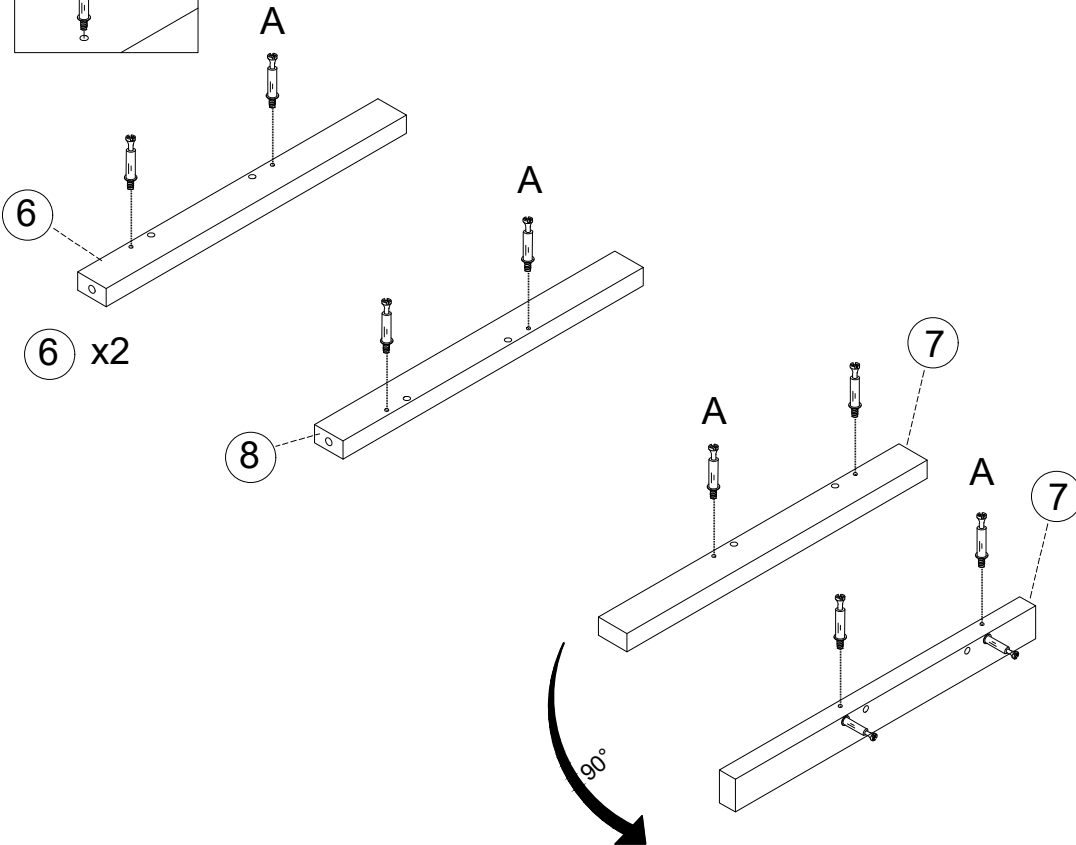
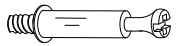

3

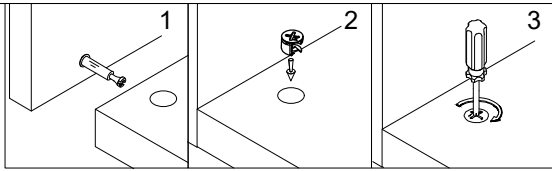

B x2

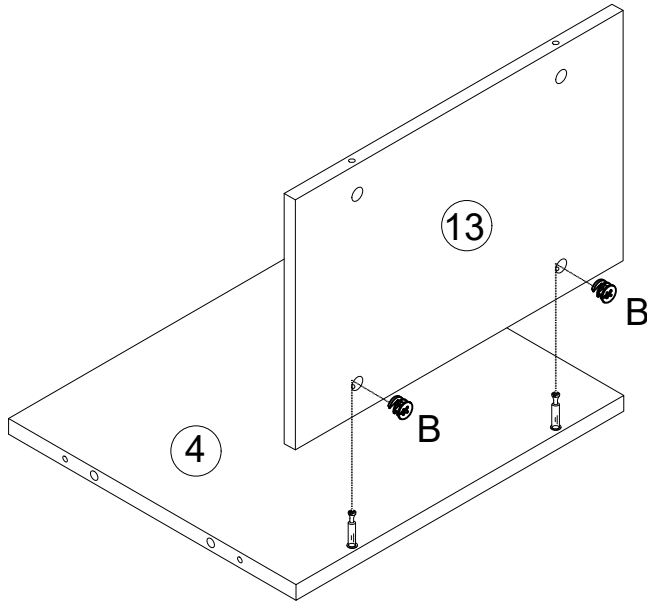

4

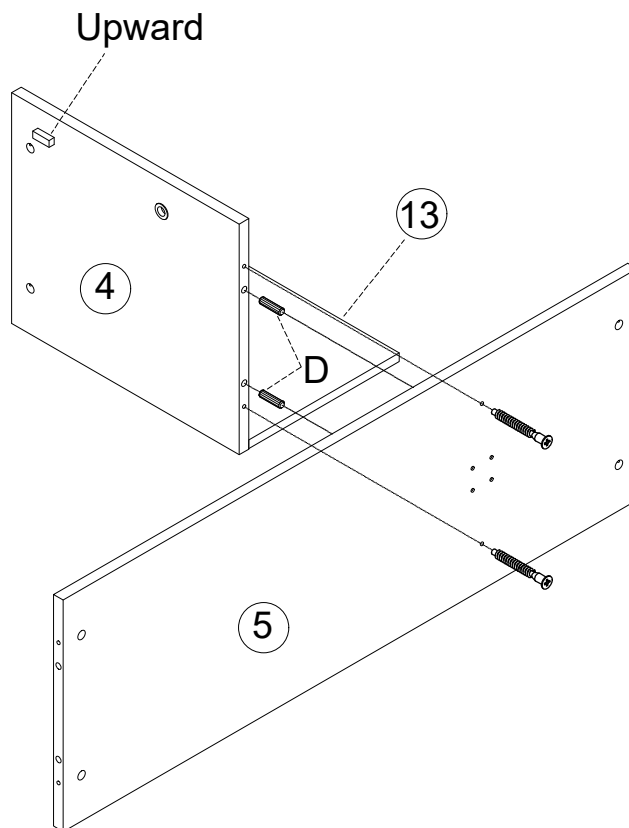

D x2

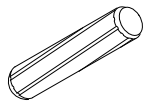

E x2

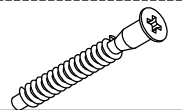

5

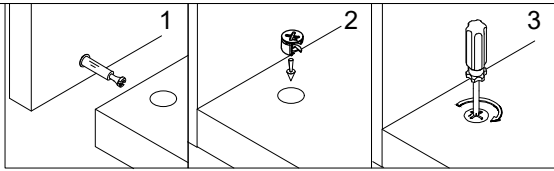

B x4



D x4

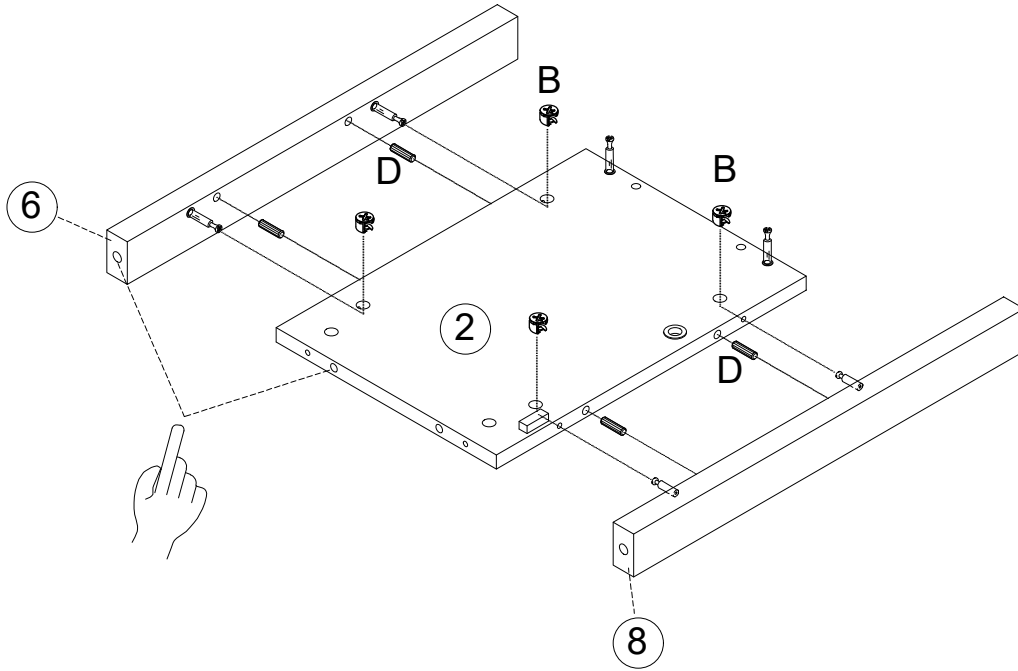
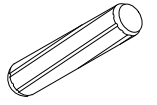

6

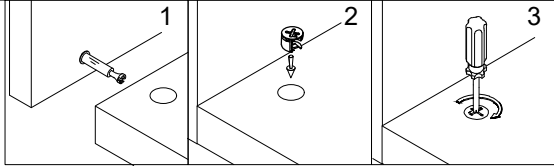

B x4



x4

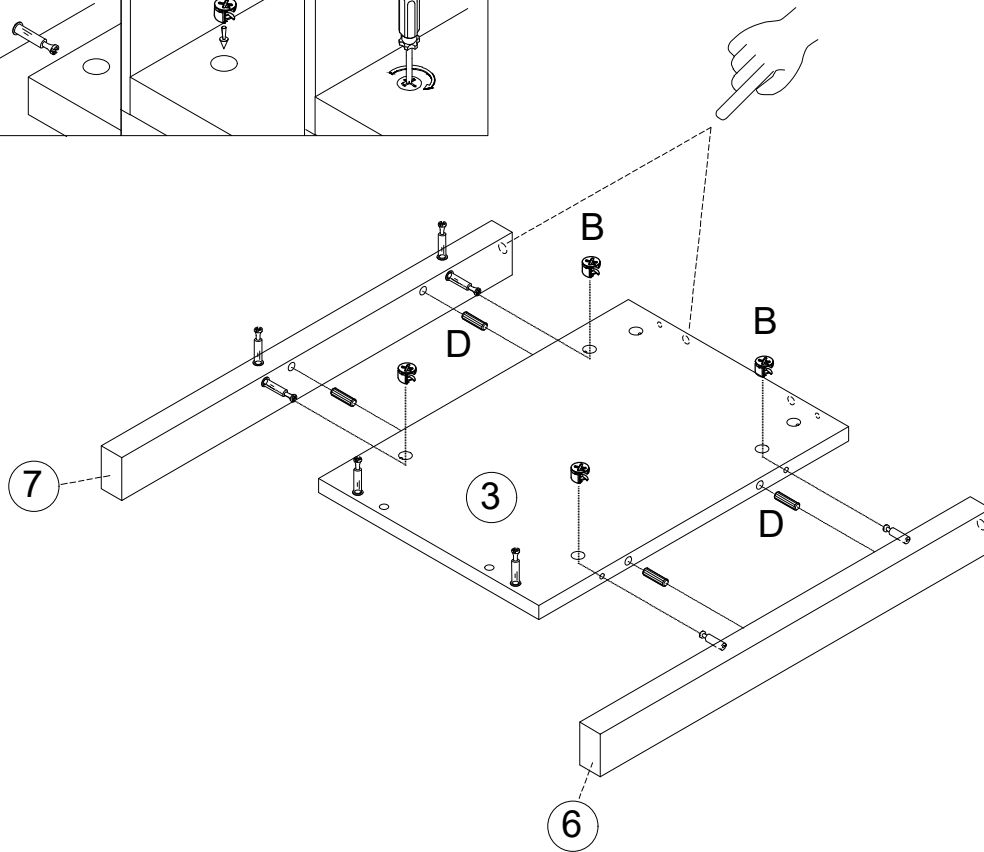
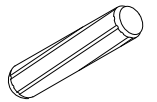

7

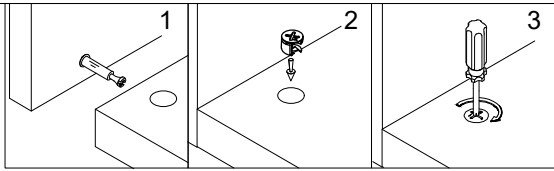

B x6



D x4

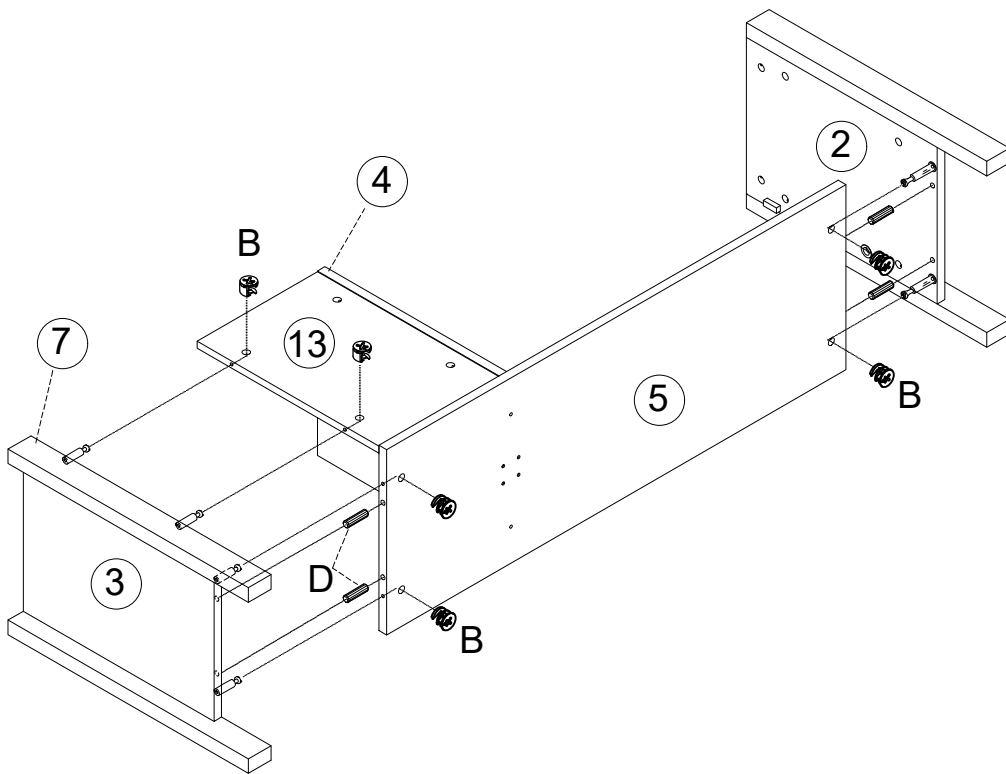
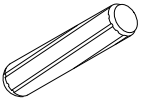

8

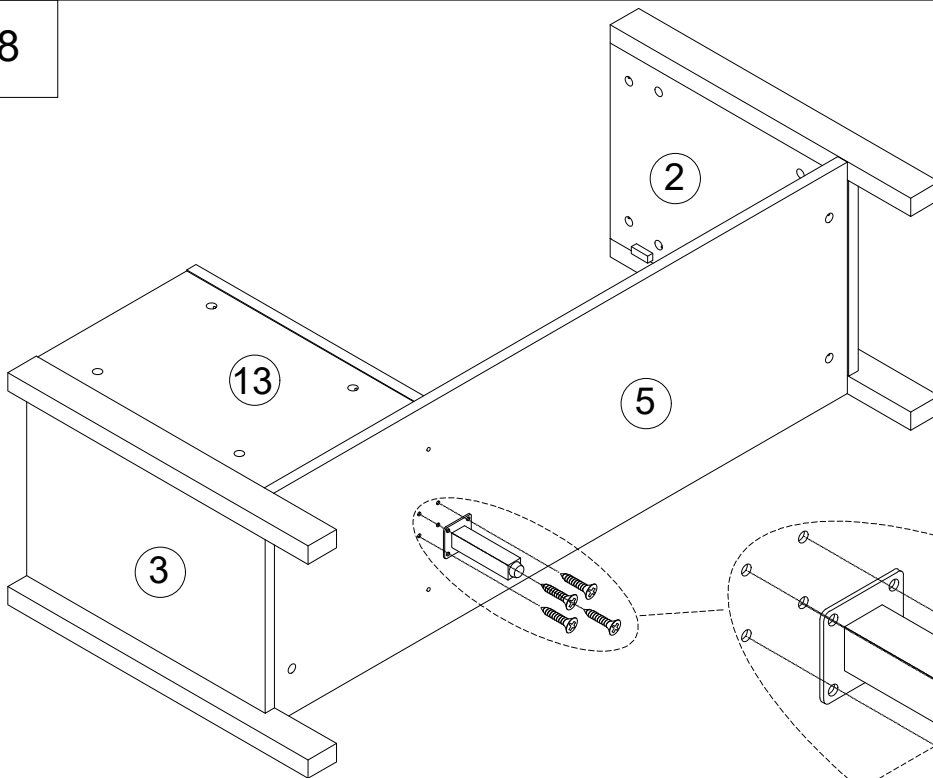

O x1

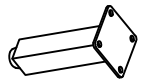

P x4

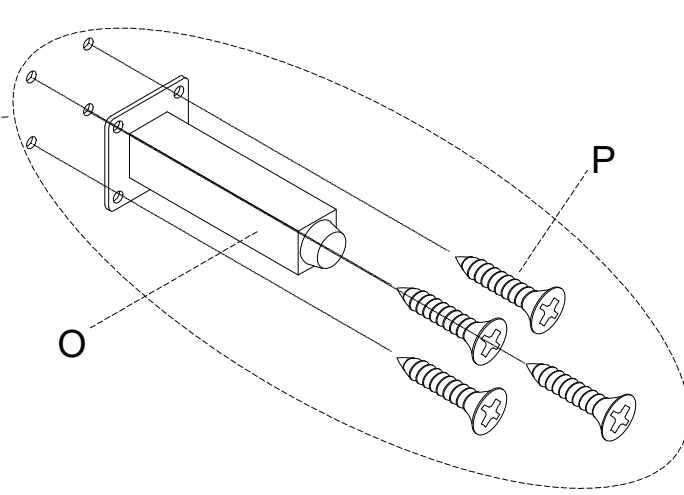
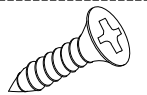

9

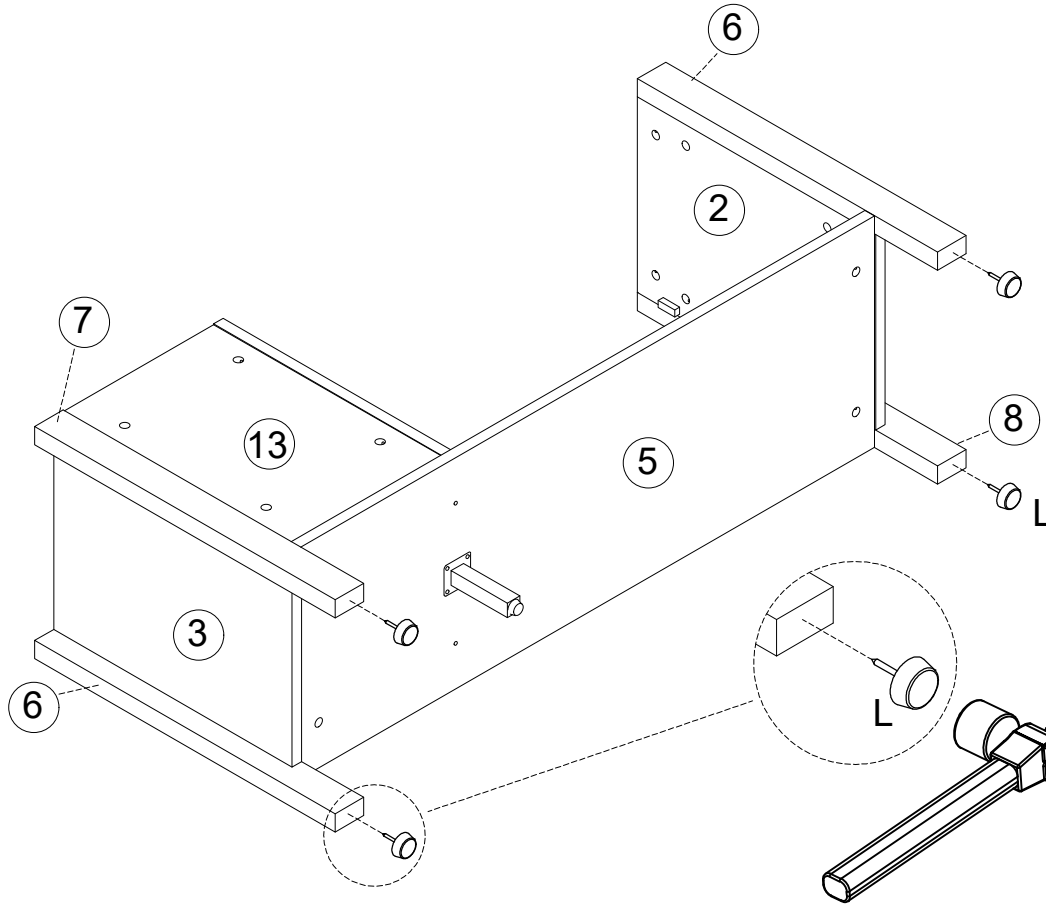

L x4

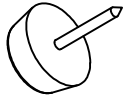

10

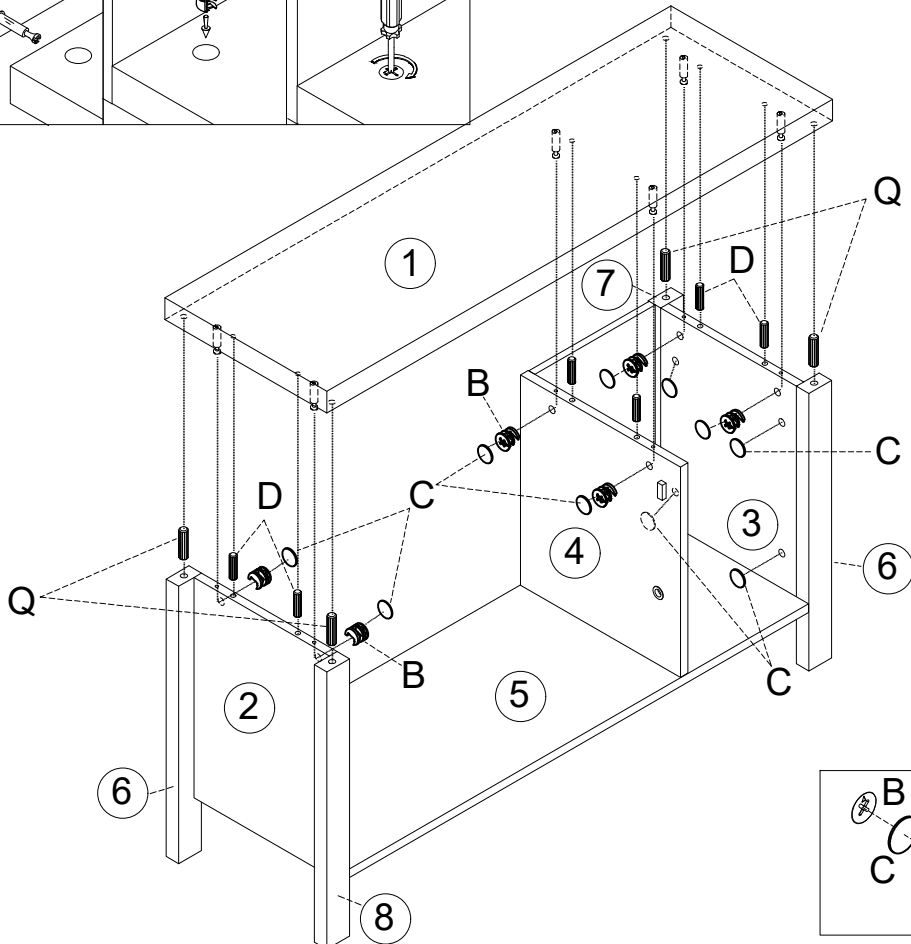
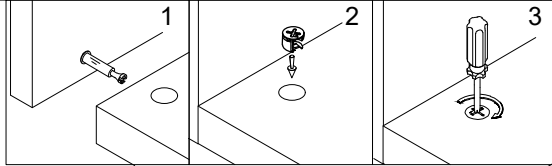

B x6



C x10

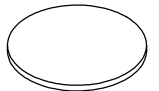

D x6

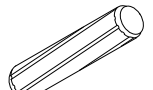

Q x4

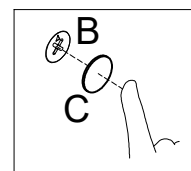
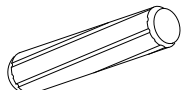

11

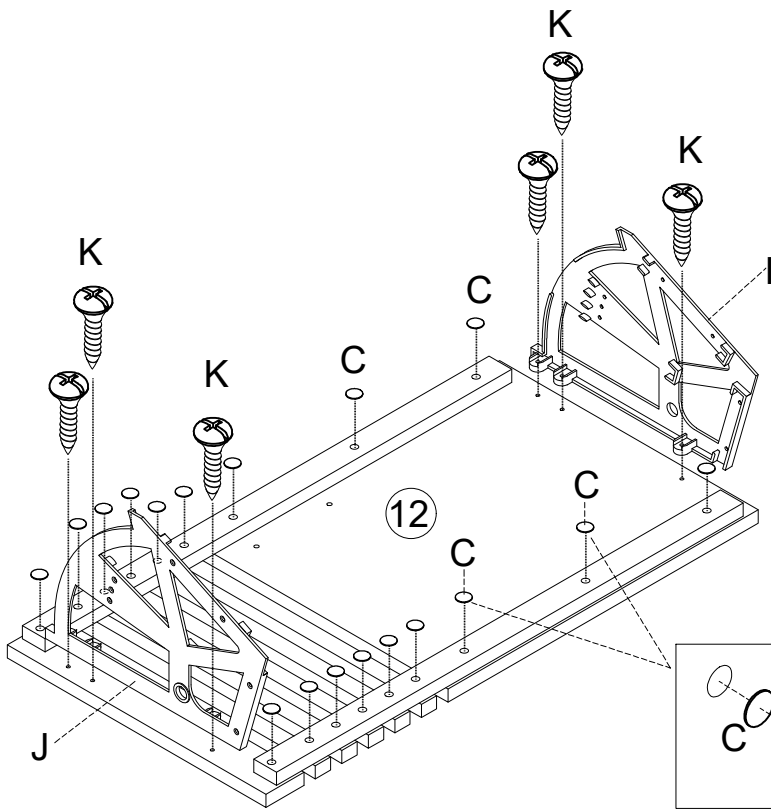

I x1



J x1

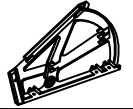

K x6

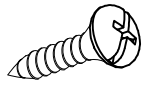

C x18

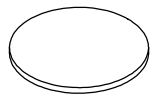

12

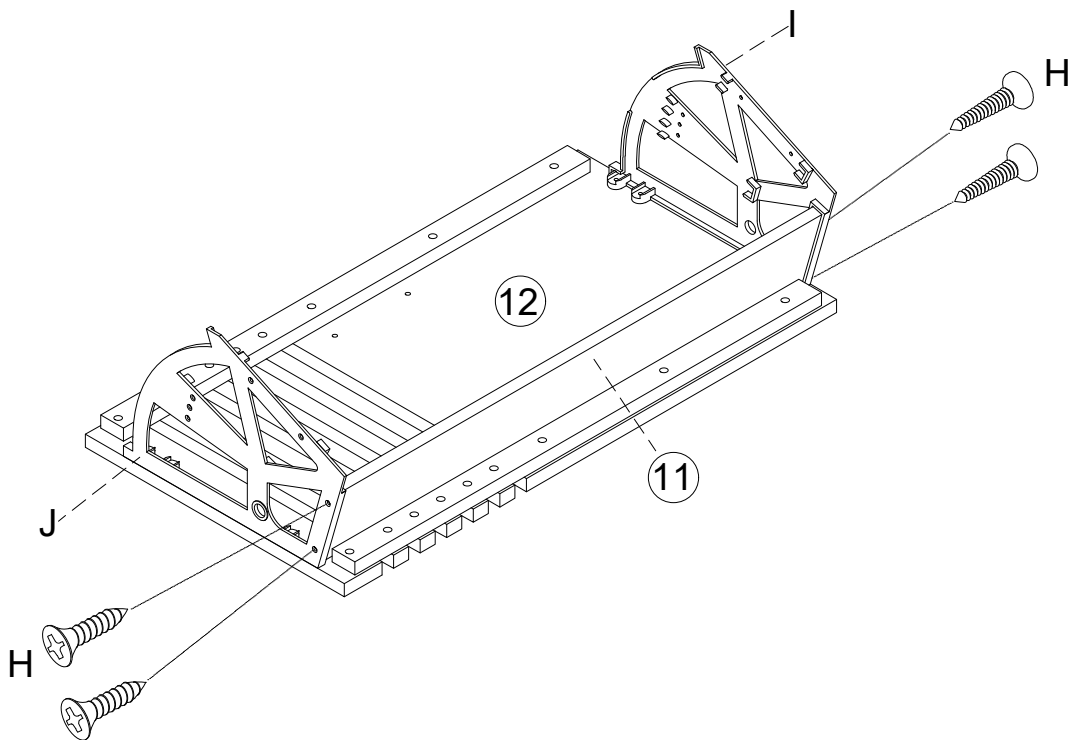

H x4

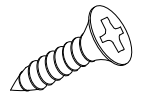

15

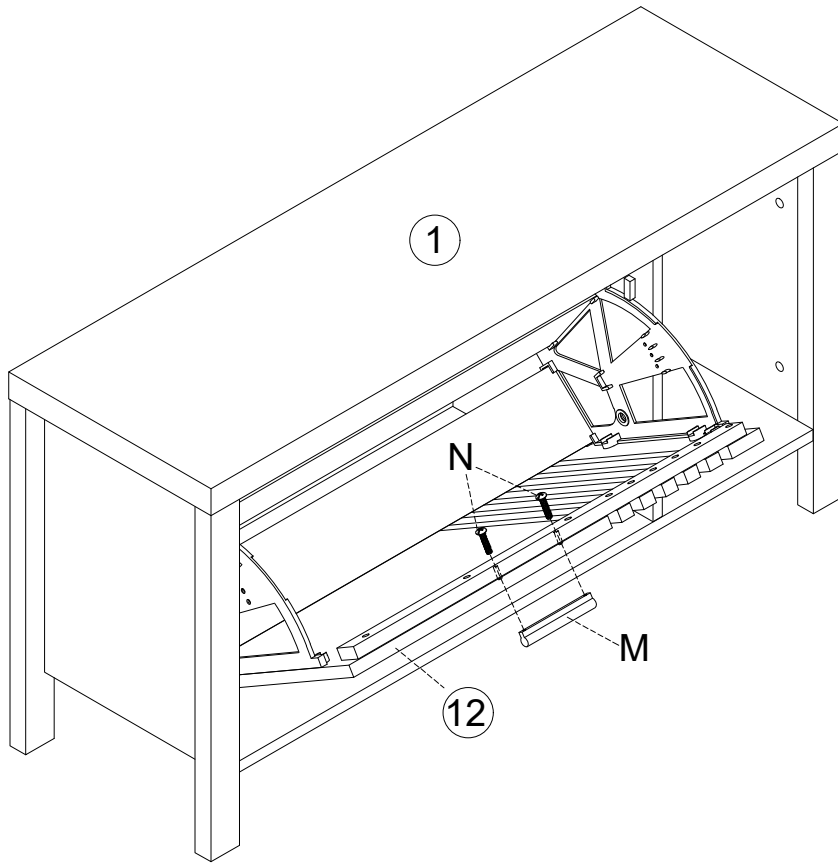

M x 1

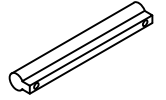

N x 2

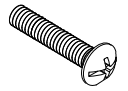

16

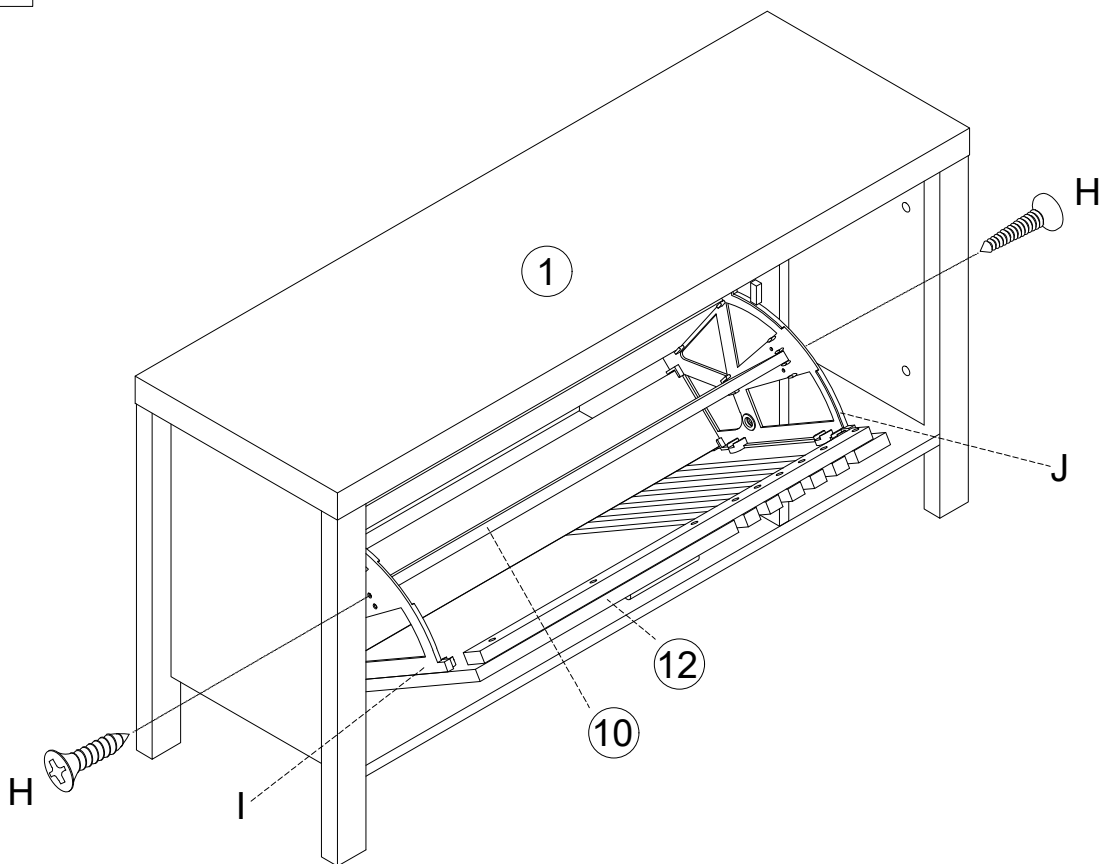

H x 2

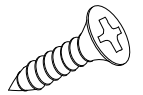

17

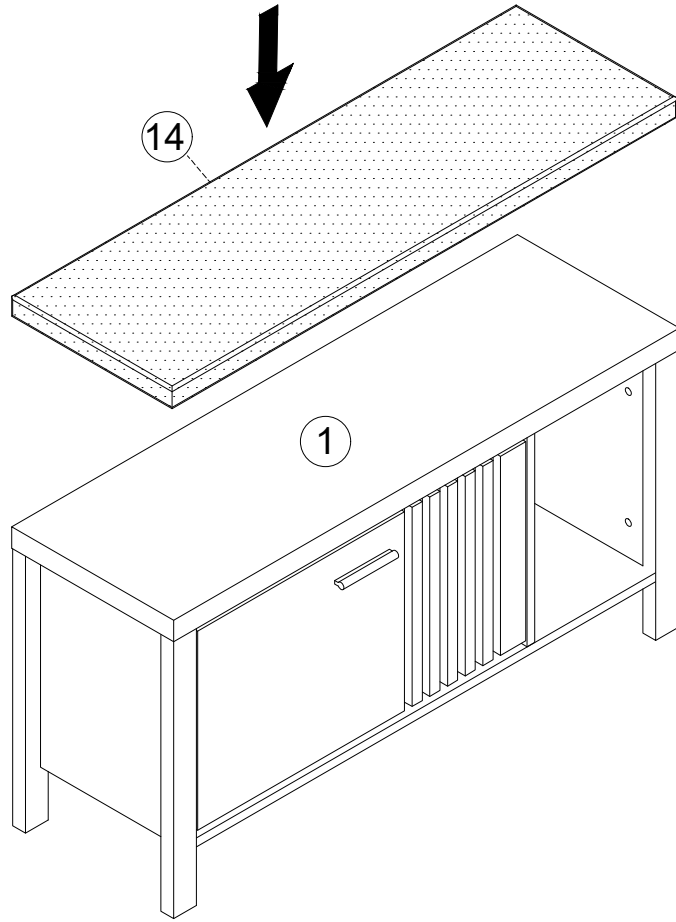

18

