

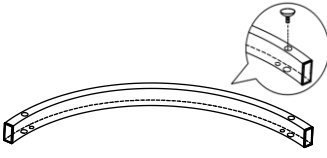

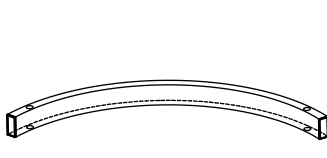
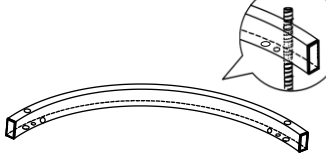
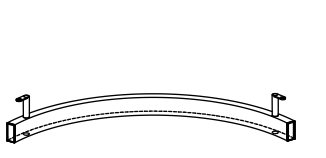

ASSEMBLY INSTRUCTION

COCKTAIL TABLE

A Stretcher  2pcs	B Stretcher  4pcs	C Stretcher  2pcs	D Stretcher  4pcs
E Connector Tube  12pcs	F Glass Top  1pc	G Long Bolt w/ Stopper 424mm  4pcs	H Bolt 3/16"x3/8"  8pcs
I Nut 1/4"  4pcs	J Glass Pad  4pcs	K Open Wrench 10mm  1pc	L Allen Wrench 1/4"  1pc
M Plastic Cap  4pcs			

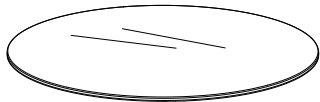
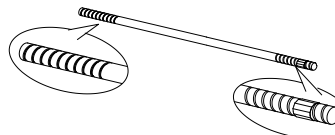
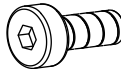

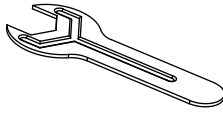
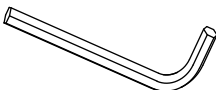
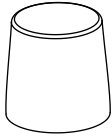
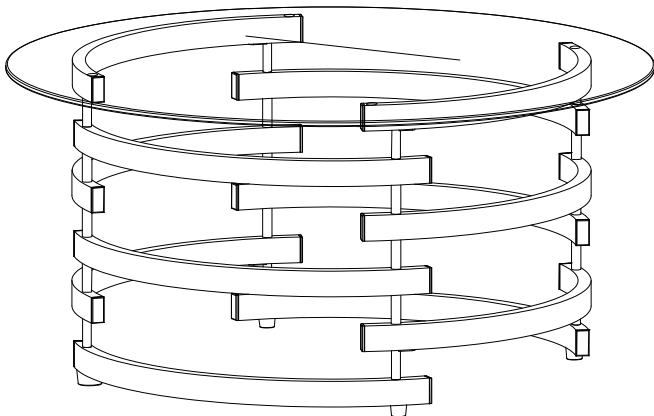
This page lists all the contents included in the box. Please take the time to identify the hardware as well as the individual components to this product. As you unpack and prepare for assembly, place the contents on a carpeted or padded area to protect them from damage.

***** Do not tighten screws & bolts until the entire unit is completely assembled.**

1

Screw long bolts (G) into corresponding holes on the bottom of stretchers (A) as shown and tighten.

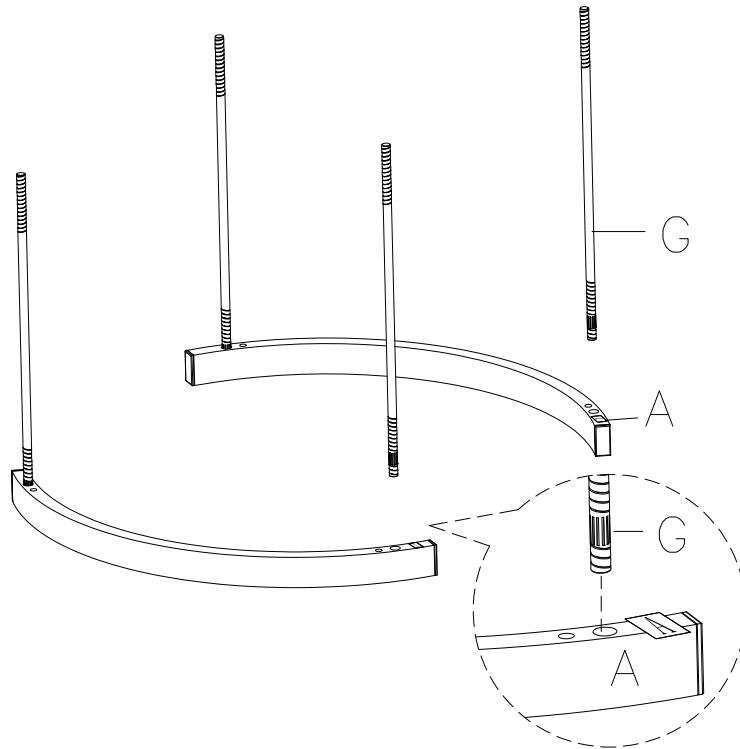

2

Insert attached long bolts (G) through the corresponding holes on stretchers (D). Secure stretchers (D) to stretchers (A) using bolts (H) and allen wrench (L), then follow with connector tubes (E) as shown.

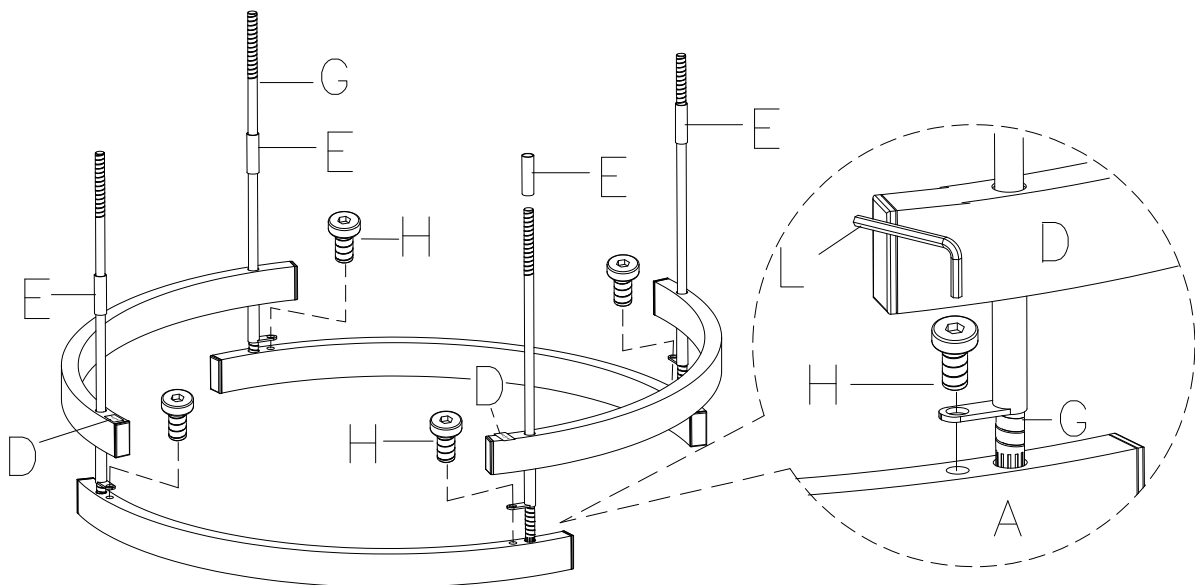

3

Attach connector tubes (E) to each long bolt (G) and follow with stretchers (B). Repeat step to add another level of stretchers (B).

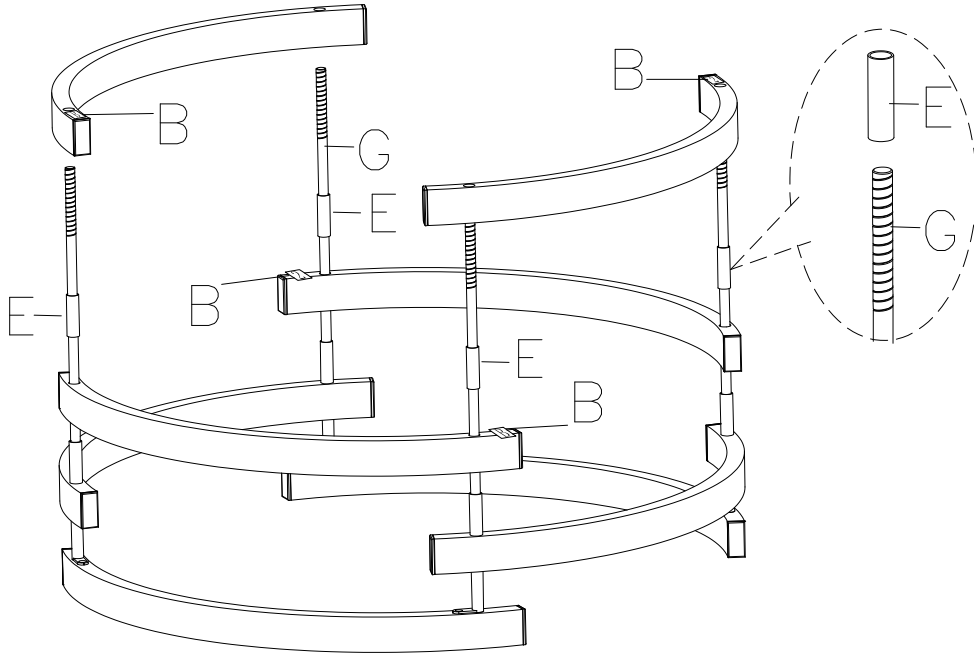

4

Attach connector tubes (E) to each long bolt (G) and add stretchers (C).

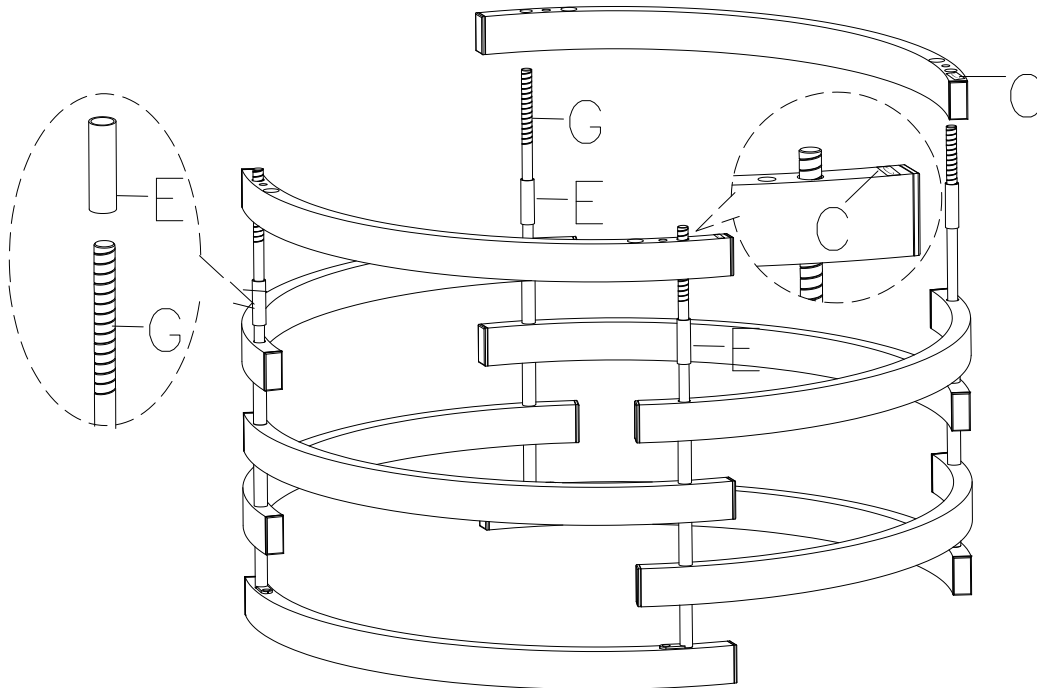

5

Attach stretchers (D) to the frame using bolts (H) and allen wrench (L) as shown. Tighten nuts (I) to fix the frame using open wrench (K). Then, put plastic caps (M) on nuts (I).

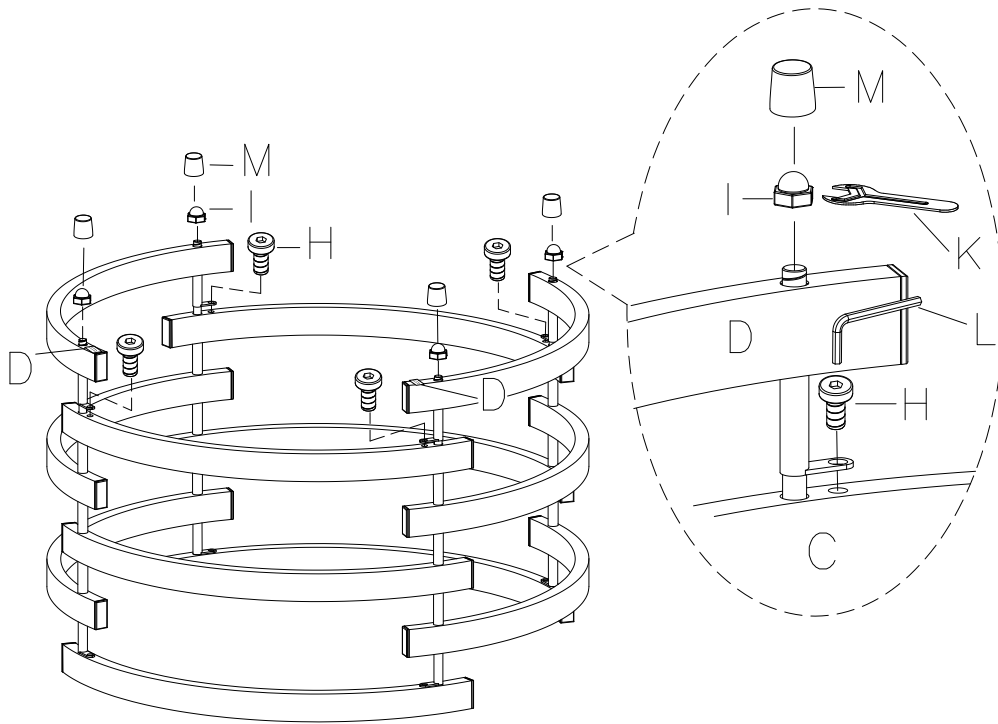
**6**

Turn the assembled frame upright and insert glass pads (J) into stretchers (A) as shown, then place glass top (F).

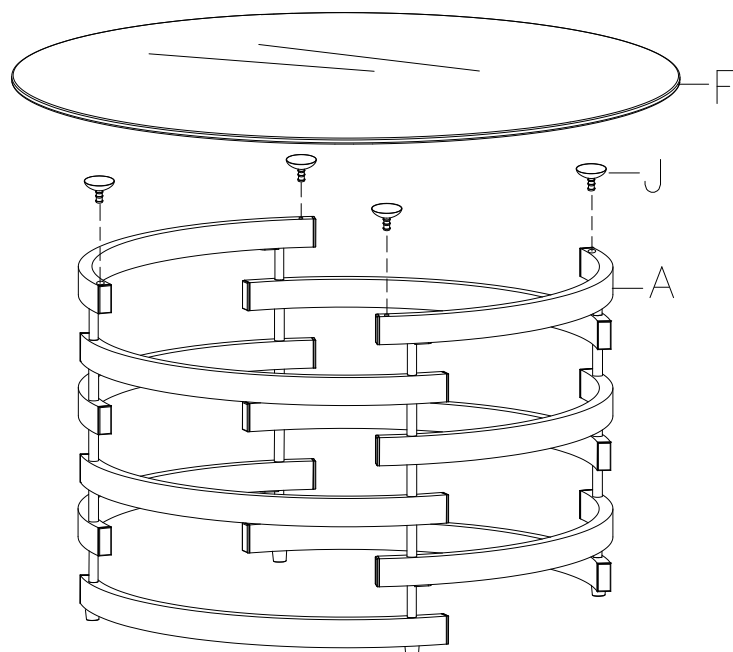

Cleaning & Care

Treat surface with care. Surface is resistant to scratches but is not scratch resistant. Clean surfaces with a dry or damp soft cloth. Do not use abrasive cleaners. Hardware may loosen over time. Periodically check that all connections are tight.