

# **CROSLEY**

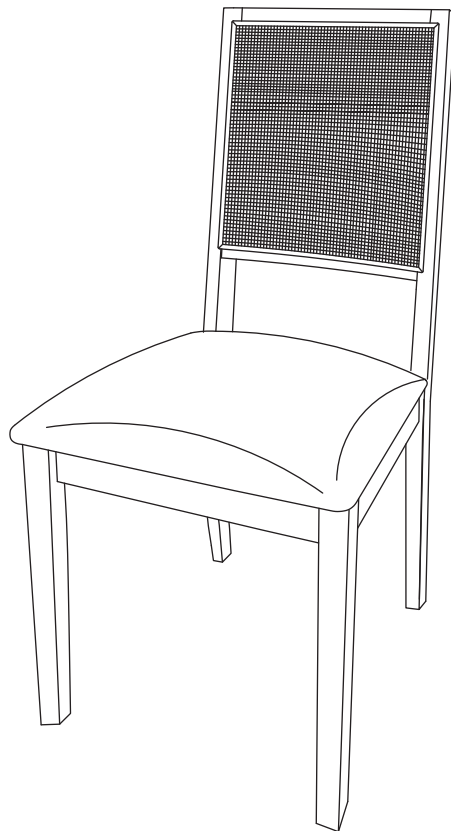

---

FURNITURE



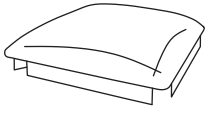

## Dining Chair CF503119



# PART LIST

<p><b>A</b></p> 	<p><b>B</b></p> 	<p><b>C</b></p> 
<p>Seat 2 PCS</p>	<p>Back 2 PCS</p>	<p>Leg 4 PCS</p>

# HARDWARE LIST

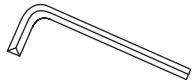
<p><b>#1</b></p>  <p>M6 X 80mm</p>	<p><b>#2</b></p>  <p>M6 X 60mm</p>	<p><b>#3</b></p>  <p>M6 X 35mm</p>	<p><b>#4</b></p>  <p>M6</p>	<p><b>#5</b></p>  <p>M6</p>
<p>Long Bolt 8 PCS (Extra 1)</p>	<p>Medium Bolt 8 PCS (Extra 1)</p>	<p>Short Bolt 2 PCS (Extra 1)</p>	<p>Spring Washer 18 PCS (Extra 1)</p>	<p>Flat Washer 18 PCS (Extra 1)</p>
<p><b>#6</b></p>  <p>M4</p>				
<p>Allen Wrench 1 PC</p>				

## ADDITIONAL TOOLS (Not Provided)

Note : It is not recommended to use power tools during assembly.

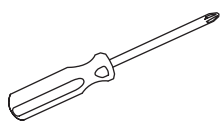



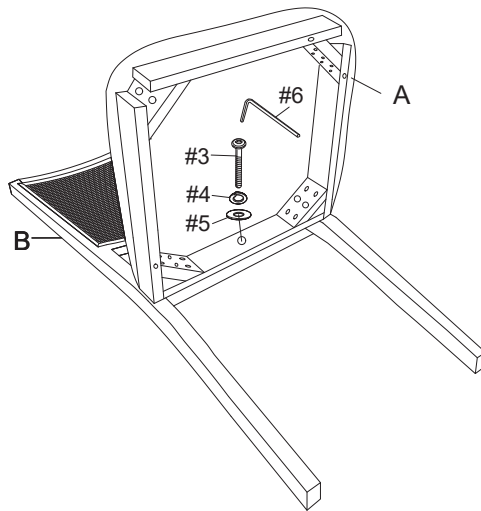

Phillips Head Screwdriver

Step 1. Lay back (part B) down on a soft surface, such as carpet. Attach seat (part A) to back (part B) using short bolt (part #3), spring washer (part #4), flat washer (part #5) and allen wrench (part #6).

NOTE: Please do not fully tighten bolt until unit is fully assembled.





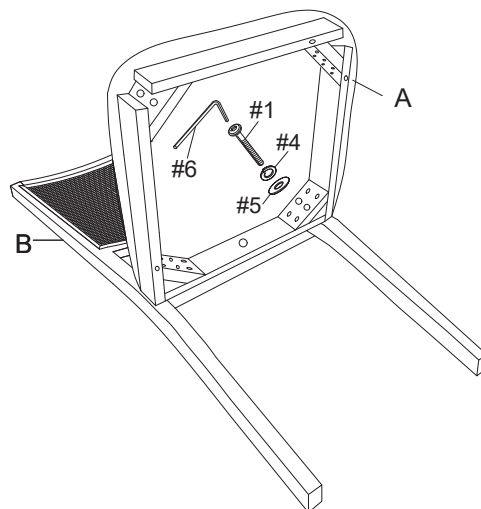

- |    |   |    |
|----|---|----|
| #3 |    | x1 |
| #4 |    | x1 |
| #5 |    | x1 |
| #6 |  | x1 |

Step 2. Secure corners on seat (part A) to back (part B) using long bolts (part #1), spring washers (part #4), flat washers (part #5) and allen wrench (part #6).

NOTE: Please do not fully tighten bolts until unit is fully assembled.





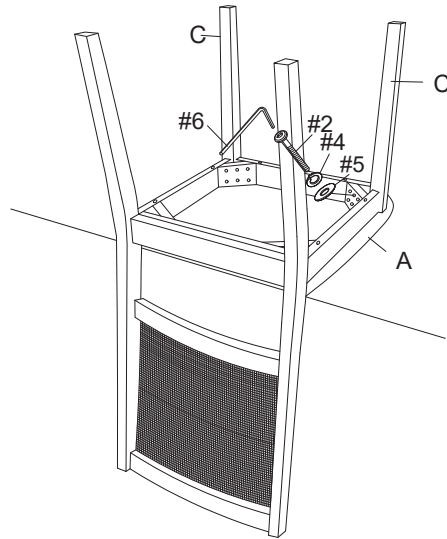

- |    |   |    |
|----|---|----|
| #1 |  | x4 |
| #4 |  | x4 |
| #5 |  | x4 |
| #6 |  | x1 |

Step 3. Attach legs (part C) to seat (part A) using medium bolts (part #2), spring washers (part #4), flat washers (part #5) and allen wrench (part #6).

NOTE: Please do not fully tighten bolts until unit is fully assembled.



#2		x4
#4		x4
#5		x4
#6		x1

Step 4. Carefully turn unit upright. Repeat step 1-3 to assemble remaining chair.

