

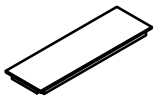

ASSEMBLY INSTRUCTIONS

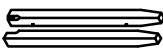

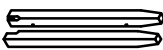
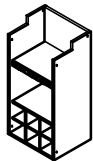
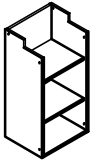

GATHERING BAR TABLE & 2 STOOLS (3 PC SET)

Thank you for purchasing this quality product. Be sure to check all packing materials carefully for small parts, which may have come loose inside the carton during shipment. Identify and count all items and compare with the parts list and/or hardware list shown below.

PARTS LIST

| NO | DESCRIPTION | SKETCH | QTY |
|----|----------------|---|-------|
| 1 | TABLE TOP |  | 1 PC |
| 2 | TABLE LEG (L) |  | 2 PCS |
| 3 | TABLE LEG (R) |  | 2 PCS |
| 4 | WINE RACK BODY |  | 1 PC |
| 5 | SHELF BODY |  | 1 PC |
| 6 | CROSS BAR |  | 1 PC |

HARDWARE LIST

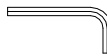
| NO | DESCRIPTION | SKETCH | QTY |
|----|-----------------------|---|--------|
| A | JCBC BOLT - M6 x 60mm |  | 8 PCS |
| B | JCBC BOLT - M6 x 30mm |  | 14 PCS |
| C | SPRING WASHER - M6 |  | 22 PCS |
| D | FLAT WASHER - M6 |  | 22 PCS |
| E | ALLEN KEY - M4 |  | 1 PC |

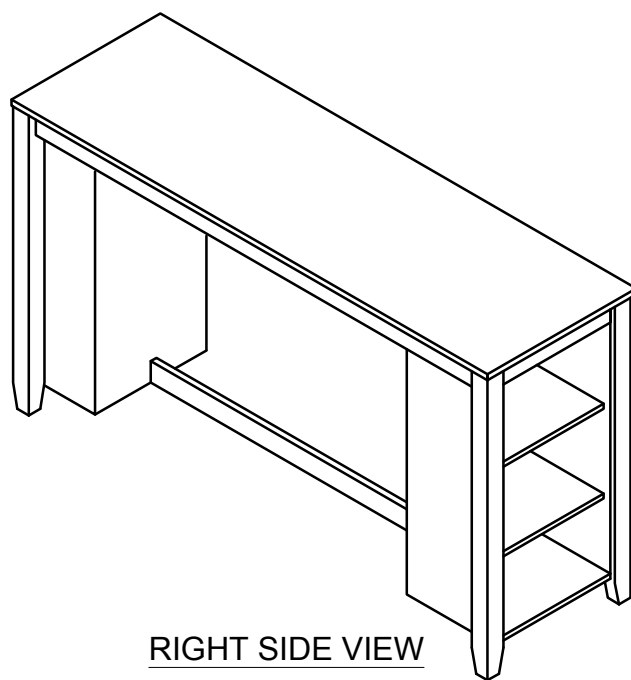
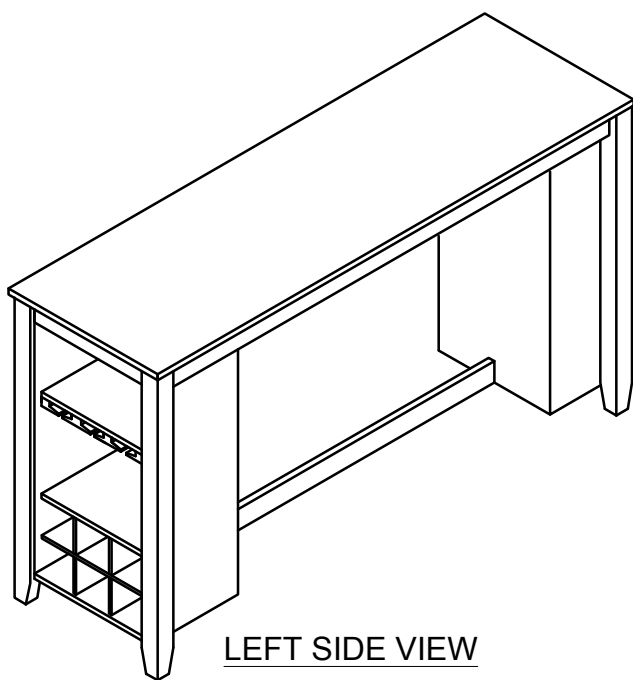

IMPORTANT NOTE :

- * Place all wooden parts on a clean and smooth surface such as a rug or carpet to avoid the parts from being scratched.
- * Check to be sure that you have all parts and hardware.
- * Remove all wrapping materials, including staples & packing straps before you start to assemble.
- * Do not tighten all screws/bolts until all completely assembled.
- * Keep all hardware parts out of reach of children.
- * We recommend that you assemble this product with the assistance of another person.

ASSEMBLY INSTRUCTIONS

GATHERING BAR TABLE & 2 STOOLS (3 PC SET)

Step 1

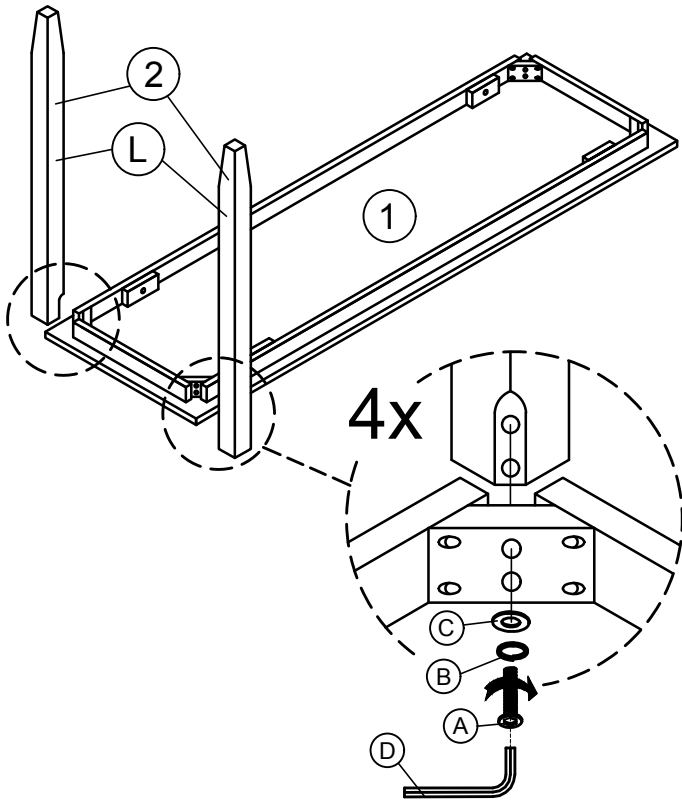

Step 2

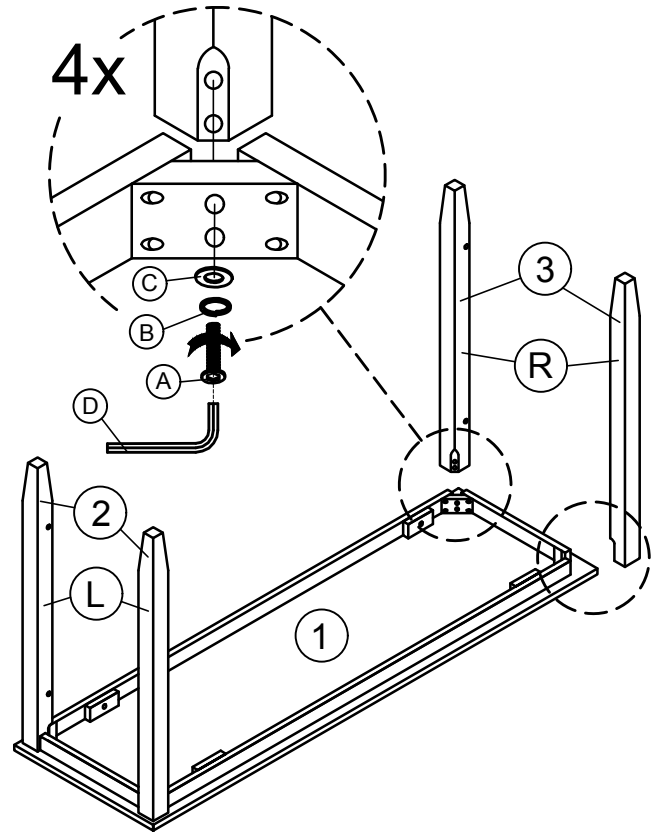

Step 3

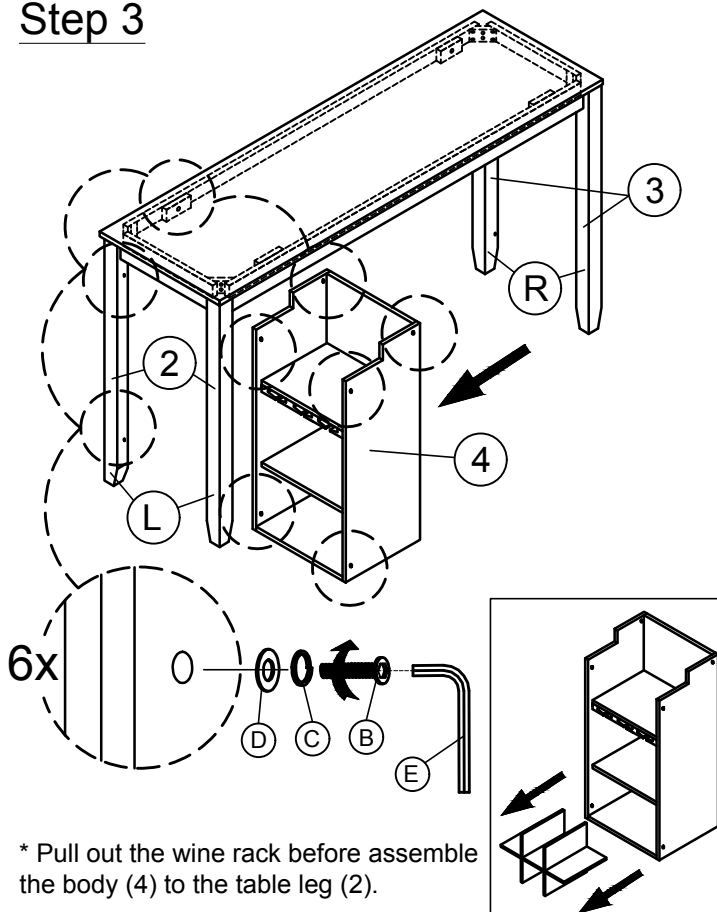

Step 4

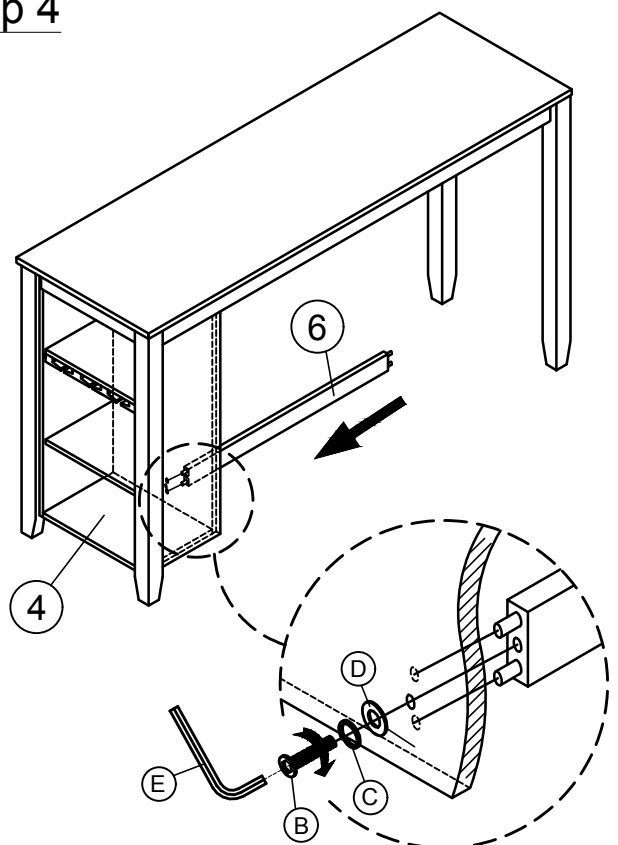

ASSEMBLY INSTRUCTIONS

GATHERING BAR TABLE & 2 STOOLS (3 PC SET)

Step 5

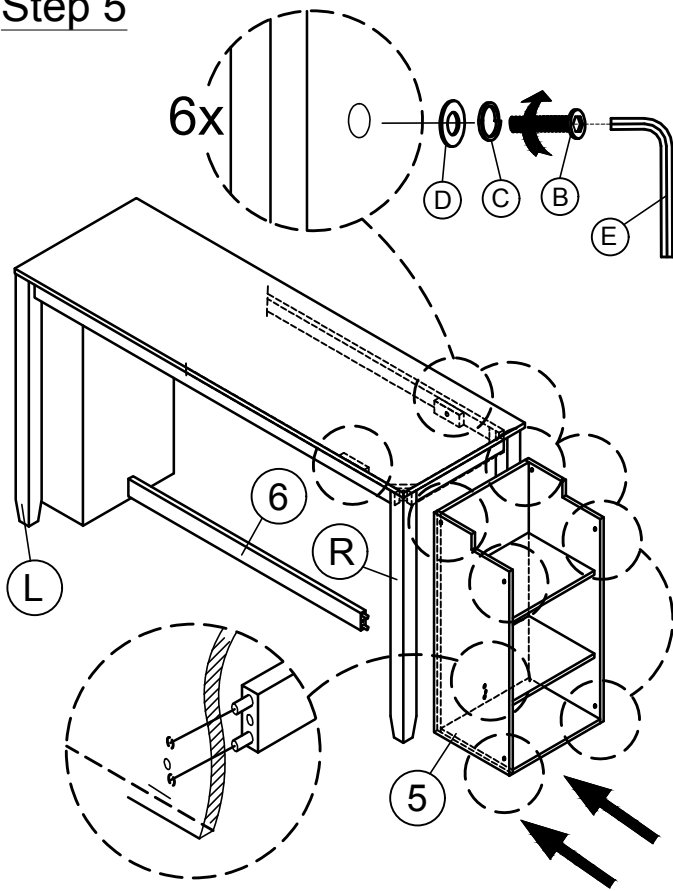

Step 6

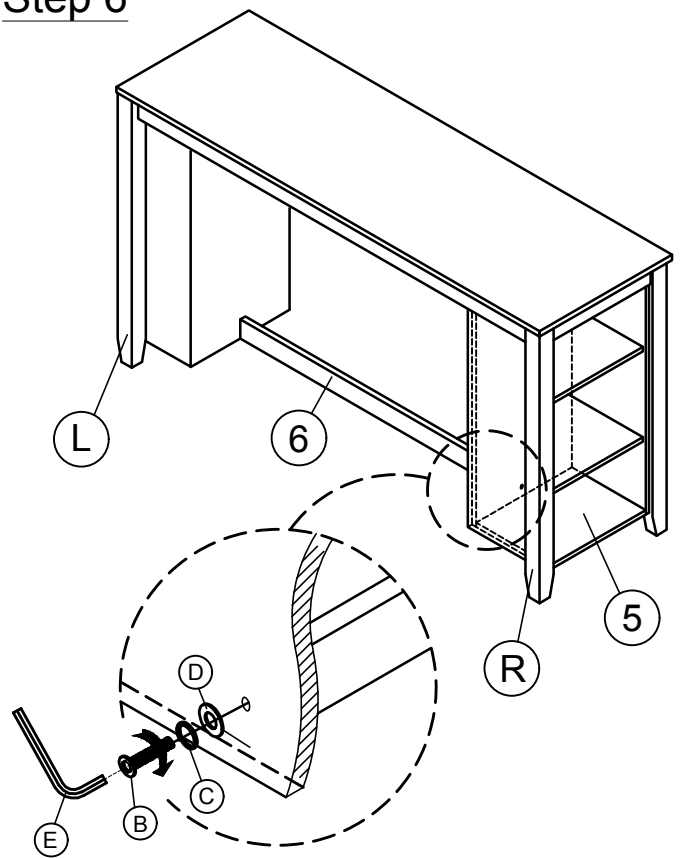

Step 7

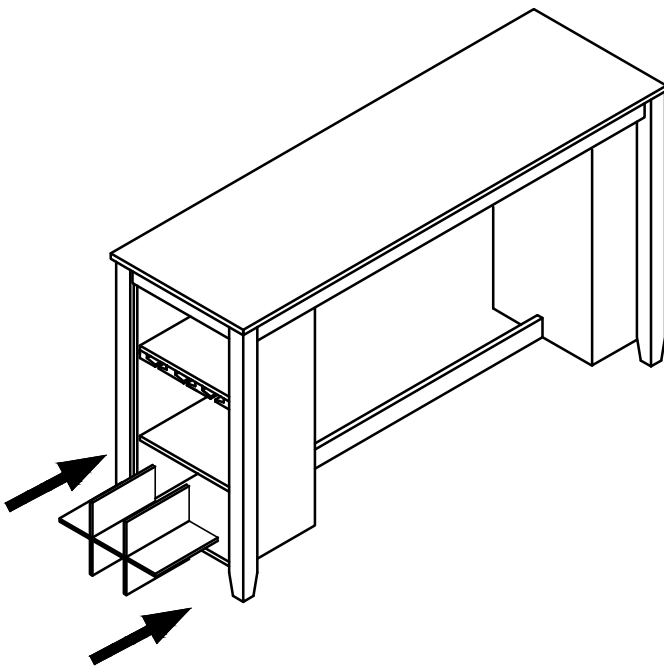

* Insert back the wine rack into the body (3) after complete the STEP 6.



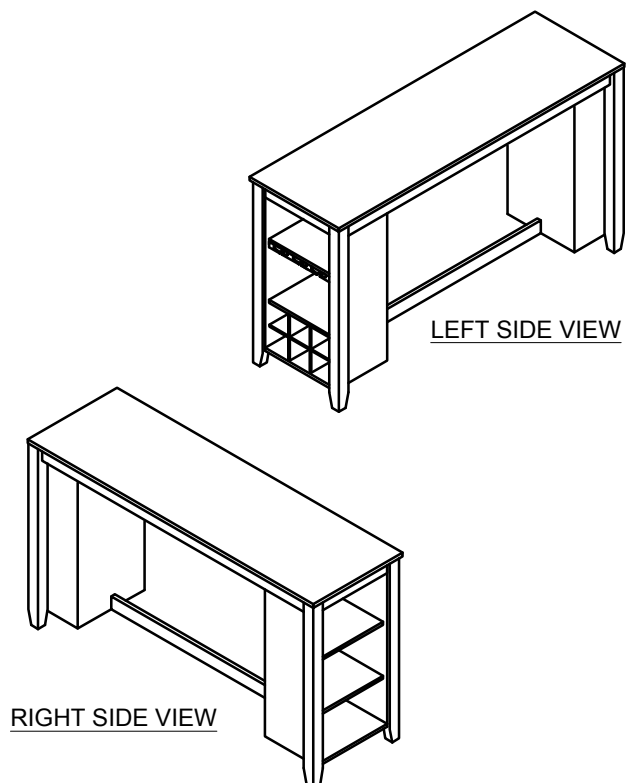

COMPLETE ASSEMBLY







ASSEMBLY INSTRUCTIONS

GATHERING BAR TABLE & 2 STOOLS (3 PC SET)

Thank you for purchasing this quality product. Be sure to check all packing materials carefully for small parts, which may have come loose inside the carton during shipment. Identify and count all items and compare with the parts list and/or hardware list shown below.

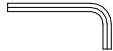
| PARTS LIST | | | |
|------------|---------------------|---|-------|
| NO | DESCRIPTION | SKETCH | QTY |
| 1 | CUSHION SEAT |  | 2 PCS |
| 2 | STOOL LEG (L) |  | 4 PCS |
| 3 | STOOL LEG (R) |  | 4 PCS |
| 4 | UPPER STRETCHER (A) |  | 4 PCS |
| 5 | LOWER STRETCHER (B) |  | 4 PCS |

| HARDWARE LIST | | | |
|---------------|-----------------------|---|--------|
| NO | DESCRIPTION | SKETCH | QTY |
| A | JCBC BOLT - M6 x 60mm |  | 16 PCS |
| B | SPRING WASHER - M6 |  | 16 PCS |
| C | FLAT WASHER - M6 |  | 16 PCS |
| D | ALLEN KEY - M4 |  | 1 PC |
| E | SCREW - M4 x 38mm |  | 16 PCS |

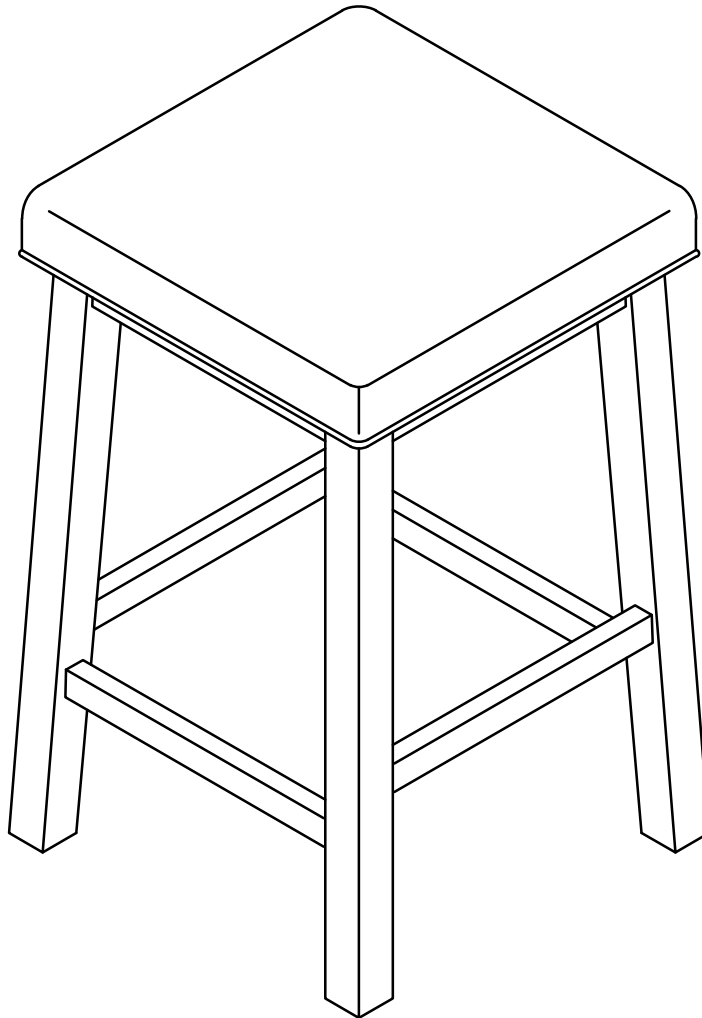

IMPORTANT NOTE :

- * Place all wooden parts on a clean and smooth surface such as a rug or carpet to avoid the parts from being scratched.
- * Check to be sure that you have all parts and hardware.
- * Remove all wrapping materials, including staples & packing straps before you start to assemble.
- * Do not tighten all screws/bolts until all completely assembled.
- * Keep all hardware parts out of reach of children.
- * We recommend that you assemble this product with the assistance of another person.

