

MAINTAINANCE AND WARNING

- Keep furniture away from heat.
- Do not clean furniture with harsh cleansers or polish. Do not use detergents, Solvents, abrasives, spray packs or leather cleaner. Use non-color mild soap with warm water clean spills(Mix 1:10 soap to water)
- Do not place furniture under direct sunlight, material will possibly fade over time.
- Do not use on site dry Cleaning machine.
- Children should not climb or jump on the furniture.
- Do not write on furniture without a padded barrier to protect the surface.
- Not for commercial use, For residential use only.



Weight Limitation
250LBS

PARTS LIST

A*1

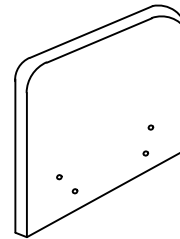

Right Arm

B*1

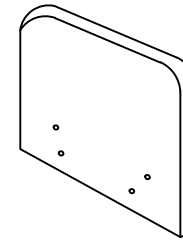

Left Arm

C*1

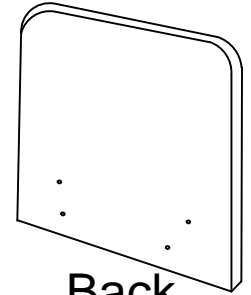

Back

D*1

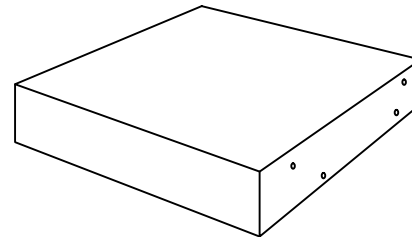

Seat Frame

E*1

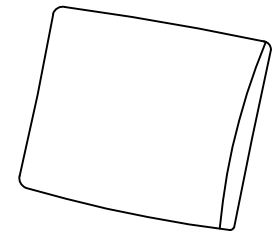

Back Cushion

F*1

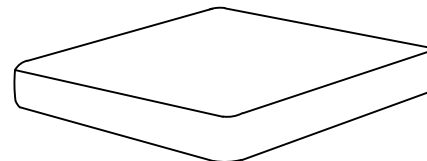

Seat Cushion

H*4

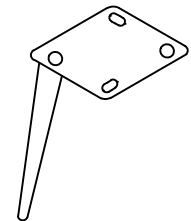

Metal Legs

HARDWARE LIST

①*12

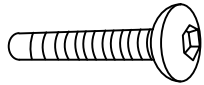

M6*70

②*12

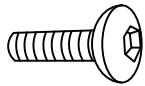

M6*20

③*12

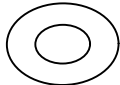

④*1



M6

SPARE

①*1

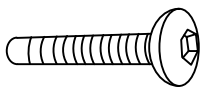

M6*70

②*1

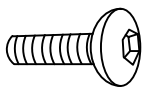

M6*20

③*1

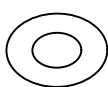

Be sure to check all packing material carefully for small parts, which may have come loose inside the carton during shipment.

ASSEMBLY INSTRUCTIONS

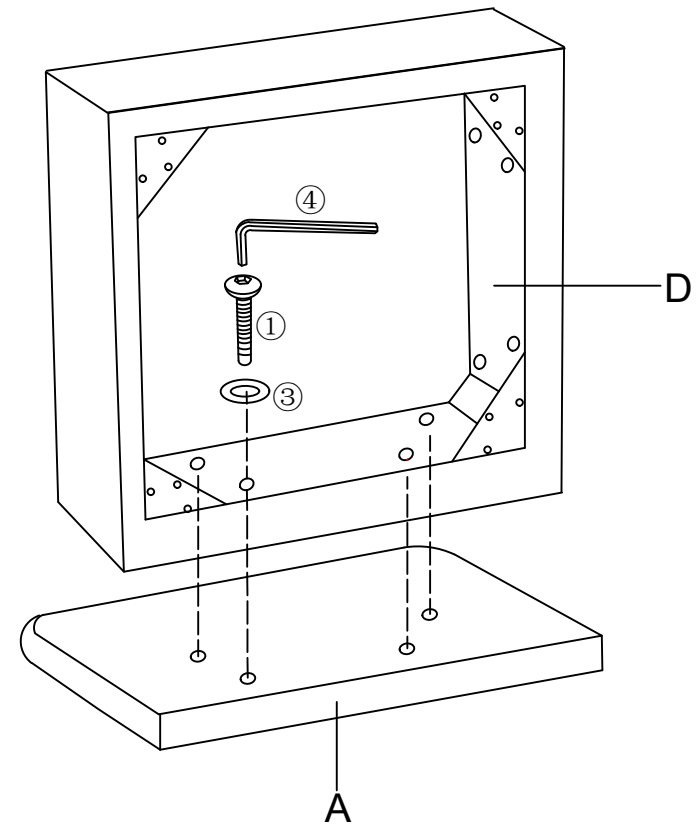

Step 1: Mark sure armrest A and sect frame D on both side, use screw and shim to connect A and D. Make sure all holes align, fasten all bolts to secure.

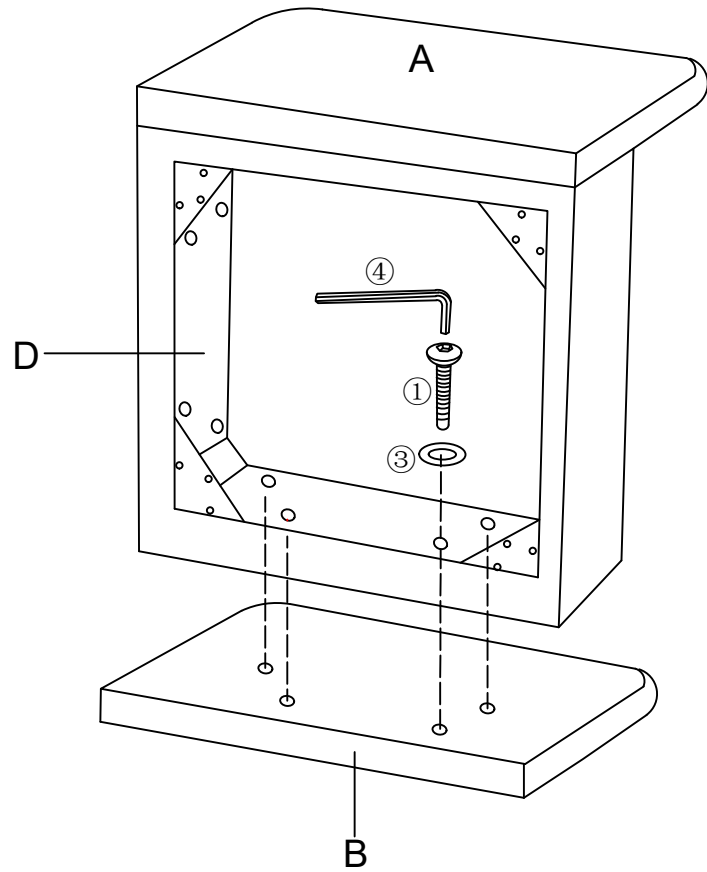

Step 2: Mark sure armrest B and sect frame D on both side, use screw and shim to connect B and D. Make sure all holes algin, fasten all bolts to secure.

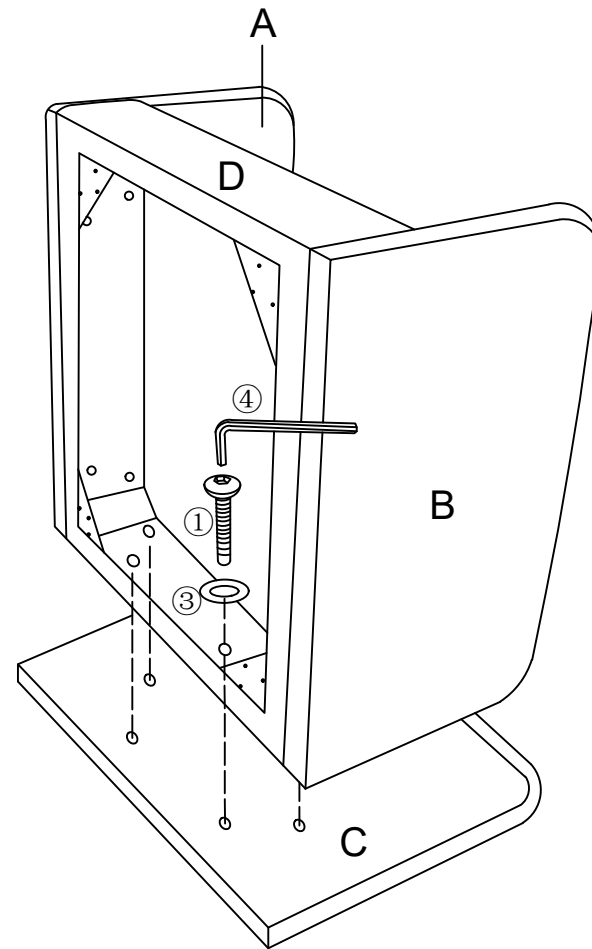

Step 3: Make sure seat frame D and back C on both. Use screw and shim to connect C and D. Make sure all holes algin, fasten all bolts to secure.

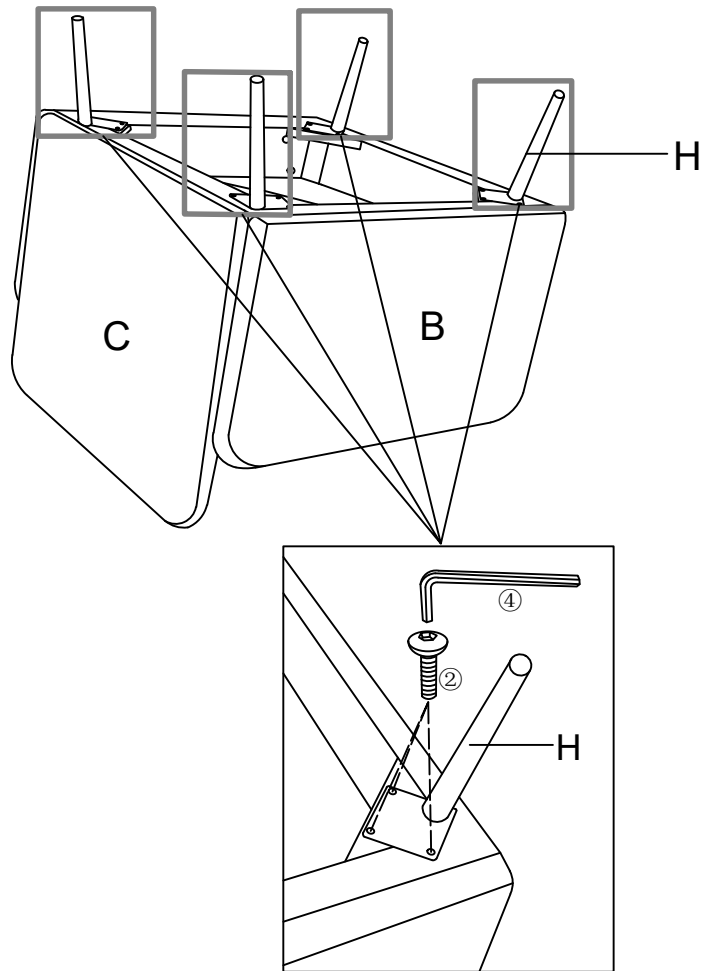

Step 4: Use key and screw to connect metal leg H and seat frame D.

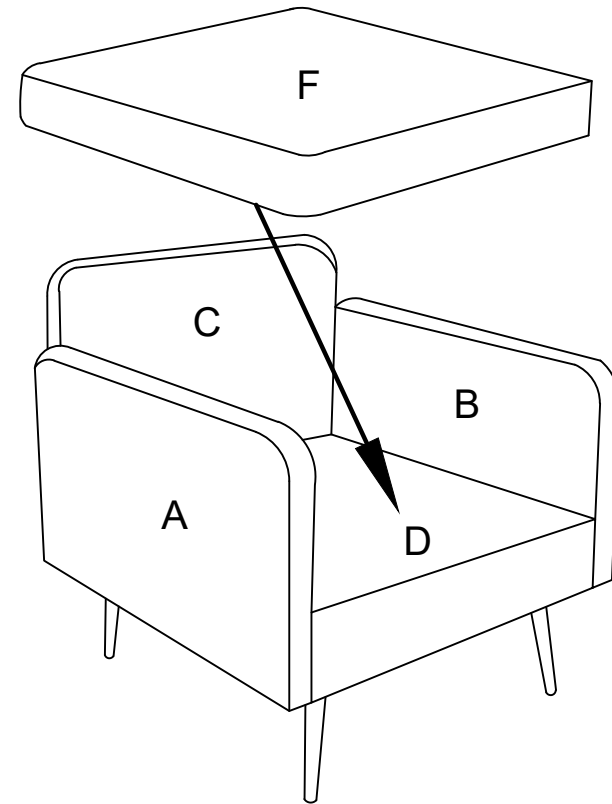

STEP 5: Place seat cushion F on top of seat frame D. Make sure gap around seat cushion sits evenly.

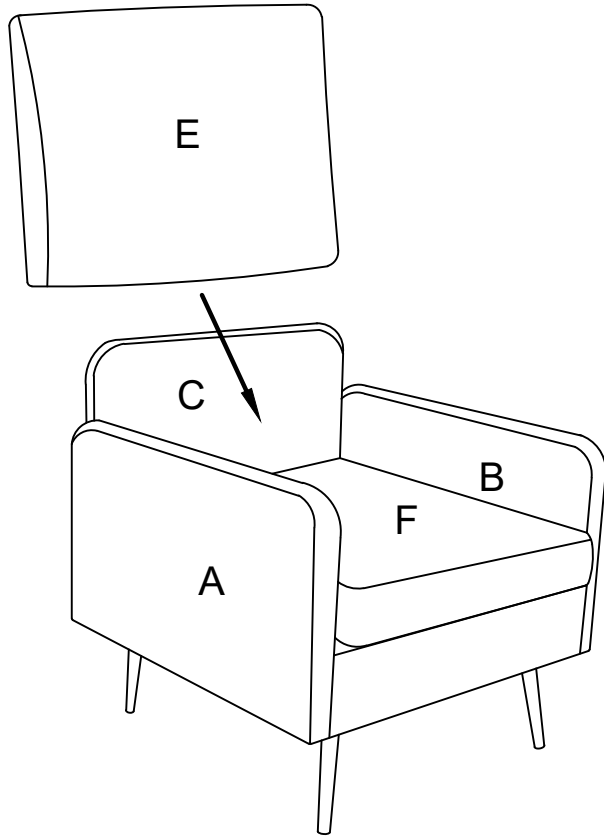

STEP 6:Place the back cushion in front of back C and on top of seat cushion F.

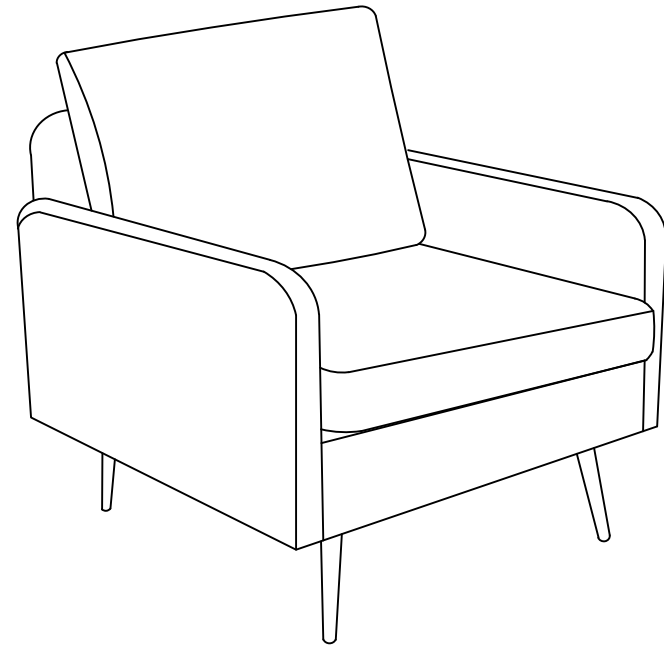
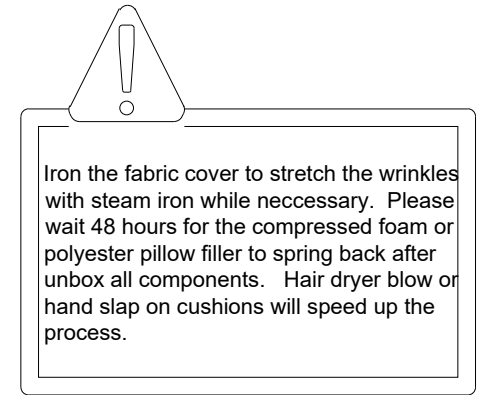

Assembly completed