

### STEP 3

Attach Top Panel (A) to the assembled unit with Top Cap (3).

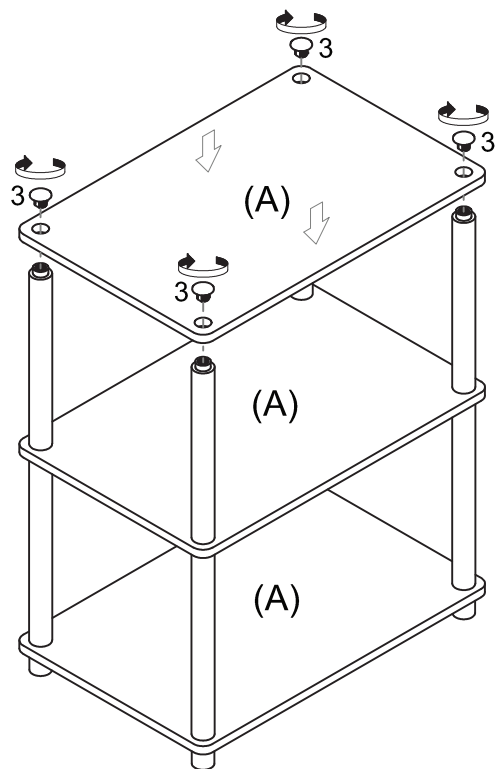

### Recommended Maximum Weight

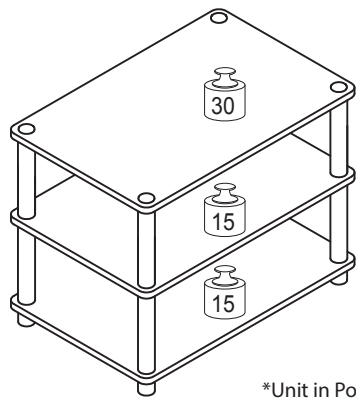

\*Unit in Pound(lbs)

### **WARNING:**

>This unit has been designed to support the maximum loads shown. Exceeding these load limits could cause sagging, instability, product collapse, and/or serious injury.

>DO NOT allow children to climb on unit.

>Put heavier items on lower shelves.

## **Assembly Instruction**

4-Tier Corner TV Stand

00:10

Approx. 10 minutes





Recomm. 1 Person

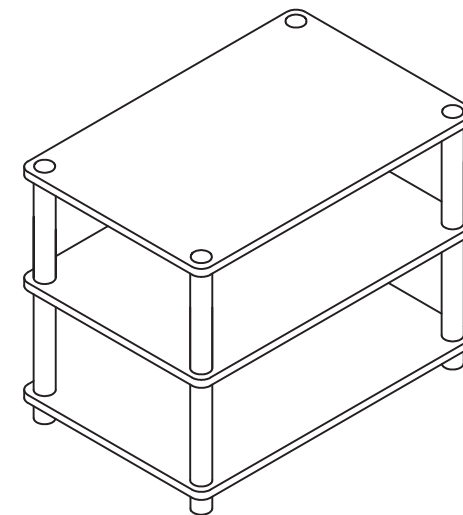

No Tools Required



No	Hardware List	Qty
1	Round Pole 	8pcs
2	Round Leg 	4pcs
3	Top Cap 	4pcs

No	Parts List	Qty
A	Top/Shelf/Bottom Panel	3pcs

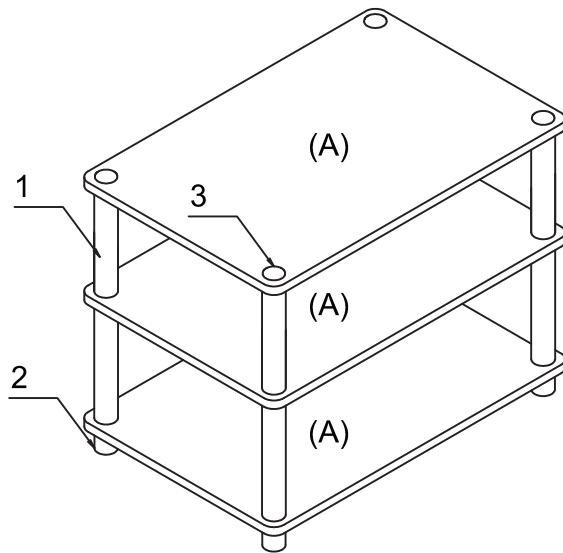

**USEFUL HINTS BEFORE YOU START:**

1. Read each step carefully before starting.
2. It is important that each step is performed in correct order to avoid difficulties.
3. Identify, sort and count the parts before assembly.
4. Assemble your furniture on packaging cardboard to prevent scratch or damage.
5. Clean the product with mild cleanser using soft damped cloth. Do not use harsh or abrasive cleanser.
6. Using incompatible hardware might cause damage to product.

**STEP 1**

Attach Round Pole (1) and Round Leg (2) with Panel (A), as shown.

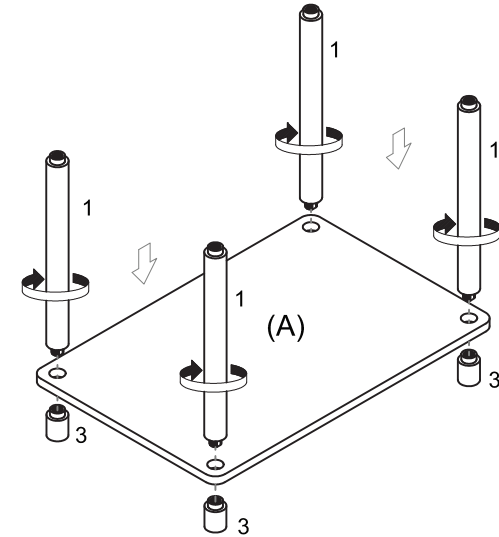

**STEP 2**

Attach another Panel (A) to the assembled unit with Round Pole (1), as shown.

