

# MPBV424

## 24" BEVERAGE CENTER

### MARVEL PROFESSIONAL COLLECTION



### MAIN FEATURES

- 5.5 cu. ft. capacity stores up to 19 wine bottles total (14 flat, 5 cradled) and holds up to 108 cans (12-oz)
- Two 3-in-1 Glide-Out Split Convertible Shelves feature removable glass pane with wine rack option to store beverages, food or wine
- Display wine rack glides out for easy access and holds up to 5 wine bottles, including magnum sizes
- Cantilevered shelving system can hold up to 35 lbs and features 11 adjustable heights
- Dynamic cooling technology delivers rapid cool down, frost-free operation, and temperature stability
- Argon-filled, UV-resistant tinted dual pane glass door options protect contents
- Digital controls allow you to select a temperature from 33°F to 70°F
- Door ajar and high/low temperature alerts
- Adjustable LED theater-style lighting in arctic white or sapphire blue
- Elegant midnight black interior
- Professional styling: Robust full-length handle and stainless steel accents
- Reversible soft-close door allows for right or left swing
- Door lock provides added security
- Panel ready model requires 3/4" or 5/8" custom panel and handle (not supplied by Marvel)

### WARRANTY

- 3-year parts and labor warranty with product registration and 5-year sealed system parts warranty (see complete warranty for details)

### FINISH OPTIONS



DOOR STYLE	MODEL NUMBER
Stainless Steel Frame Glass	MPBV424-SG31A
Panel Ready Frame Glass	MPBV424-IG31A
Solid Stainless Steel	MPBV424-SS31A
Solid Panel Ready	MPBV424-IS31A



# MPBV424

## 24" BEVERAGE CENTER



### DIMENSIONAL DRAWINGS

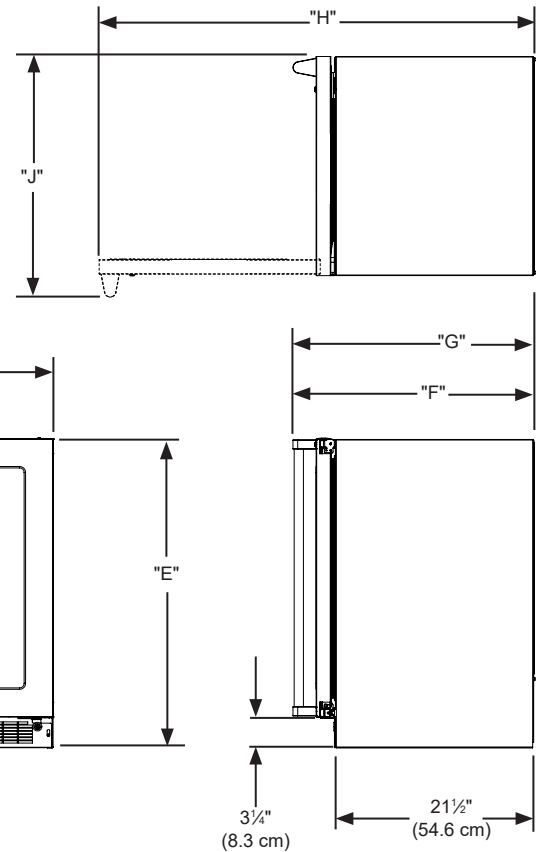
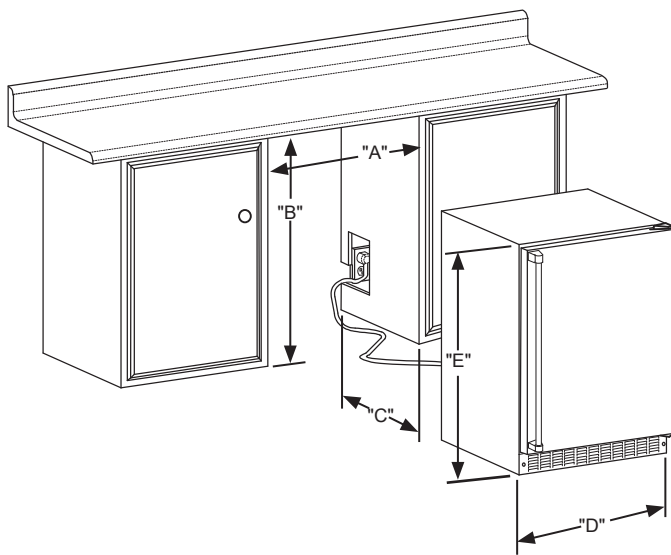

#### ROUGH IN DIMENSIONS\*

"A"	"B"	"C"
24"	34" to 35"	24"
(61 cm)	(86.4 cm to 88.9 cm)	(61 cm)

#### CABINET DIMENSIONS\*

"D"	"E"	"F"	"G"	"H"	"J"
23-7/8"	33-3/4" to 34-3/4"	23-5/8"*	26-1/8"*	47-3/4"*	26-3/8"*
(60.7 cm)	(85.7 cm to 88.3 cm)	(60 cm)	(66.4 cm)	(121.3 cm)	(67 cm)

\*Stainless steel model dimensions only. For panel-ready models, see the owner's guide online at [marvelrefrigeration.com](http://marvelrefrigeration.com).

### PRODUCT SPECIFICATIONS

<b>Capacity</b>	5.5 cu. ft.
<b>Cord Length</b>	6 ft.
<b>Electrical Requirements</b>	115V / 60 Hz / 15A
<b>ENERGY STAR</b>	Yes
<b>Panel Height</b>	30-7/16" (77.3 cm)
<b>Panel Thickness</b>	5/8" (1.6 cm) or 3/4" (1.9 cm)
<b>Panel Type</b>	2-3/4" (7 cm) Frame Panel or Solid Panel
<b>Panel Width</b>	23-5/8" (60 cm)
<b>Refrigerant Type</b>	R600a

<b>Sabbath Mode</b>	Yes
<b>Shipping Dimensions</b>	28" W x 31" D x 37" H
<b>Shipping Weight</b>	160 lbs
<b>Temperature Range</b>	33°F to 70°F

For comprehensive installation instructions, including panel overlay details, please visit [marvelrefrigeration.com](http://marvelrefrigeration.com) to access the owner's guide. All specifications are subject to change without notice.

