



IMPORTANT: READ CAREFULLY BEFORE BEGINNING

1. DO NOT USE POWER TOOLS ON THE ASSEMBLY OF THIS ITEM.
2. DO NOT TIGHTEN BOLTS UNTIL FULLY ASSEMBLED.













60qt Retro Cooler

LG 97050, LG 97051, LG 97054, LG 97056 and LG 97058

Assembly Instructions

1. Place all parts on a clean and level surface before assembling. Put body (E) upside down. Connect each leg (G/H) to the body (E) by using 3 bolts (J).
2. Attach cap catcher (F) to the body (E). Attach the lid (B).
3. Connect bottle opener (C) to body (E) by using 2 bolts (J).
4. Use the bolts (J) to secure the handle (D) and body (E).
5. Unscrew the Lid Knobs (A) from under the Lid (B) with a #2 Phillips Screwdriver and secure them on top of the Lid (B) by re-using the 2 Bolts (K).

Tools Required (Not Included):
#2 Phillips Screwdriver

PARTS & HARDWARE LIST			
A	Lid Knob		x 2
B	Lid		x 1
C	Bottle Opener		x 1
D	Handle		x 1
E	Body		x 1
F	Cap Catcher		x 1
G	Leg & Caster Without Lock		x 2
H	Leg & Caster With Lock		x 2
I	Drain Plug		x 1
J	M6 x 13 Bolt		x 20
K	M4 x 30 Bolt		x 2
L	Hex Wrench		x 1

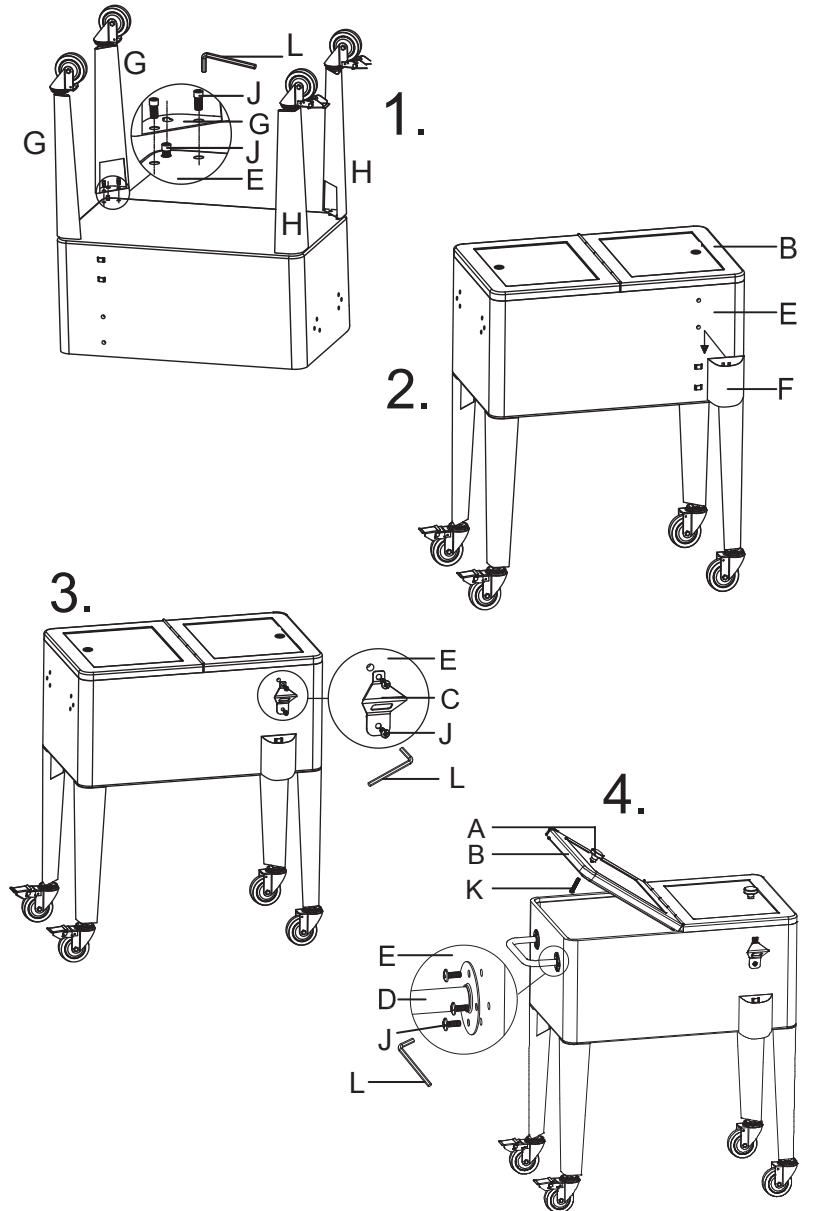

Limited One Year Finish Warranty

**** (non-transferable) ****

This product is covered under United General Supply's (UGS) one (1) year limited warranty. To the original purchaser of this piece of furniture, cooler or accessory; UGS warrants that it will be free from defects in material and workmanship for up to one year from the date of purchase under normal use and proper care.

Replacement of defective or missing parts will be sent at no charge to the customer for a period of 30 days from the date of purchase. UGS will no longer be responsible for missing parts or hardware 30 days after date of purchase. Freight, packaging, labor or material charges to and from our customer service center is not covered under the warranty and is therefore the customer's responsibility.

The limited warranty does not cover this piece of furniture, cooler or accessory for commercial purposes, abusive use, damage by modification, freeze damage, severe weather damage, rust, fading and issues caused by improper care.

For minor defects or missing parts/hardware, please contact customer service immediately upon purchase. Please do not return product to the store unless the product is irreparable. A customer service agent may help determine whether the damage is repairable and will provide further instructions.

For returns and refunds, please refer to your local store return policy with proof of purchase.

Proof of purchase (dated register receipt) will be required for warranty claims.

DO NOT USE POWER TOOLS ON THE ASSEMBLY OF THIS ITEM AS THEY MAY DAMAGE THE HARDWARE. USE OF POWER TOOLS ALSO VOID THE WARRANTY.

Customer Service may be reached Monday through Friday from 9:00a.m. to 5:00p.m. CST.

HELP@UGSCO.COM OR 1-877-87LEIGH (53444)

Leigh Country
Authentic Country® Living 

**DISTRIBUTED BY:
UNITED GENERAL SUPPLY CO., INC.
HOUSTON, TX 77036**

www.LeighCountry.com