

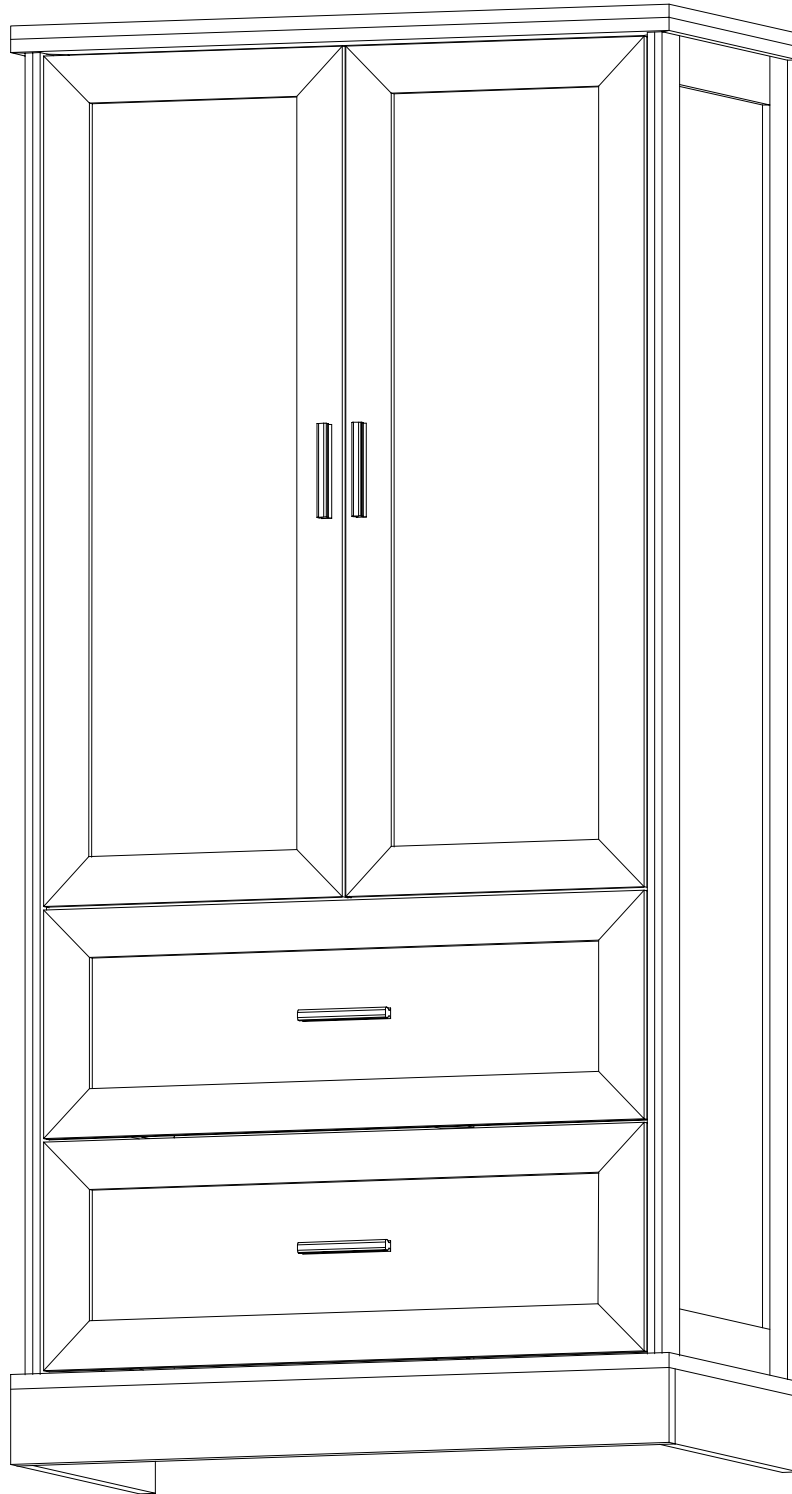

# ASSEMBLY INSTRUCTION

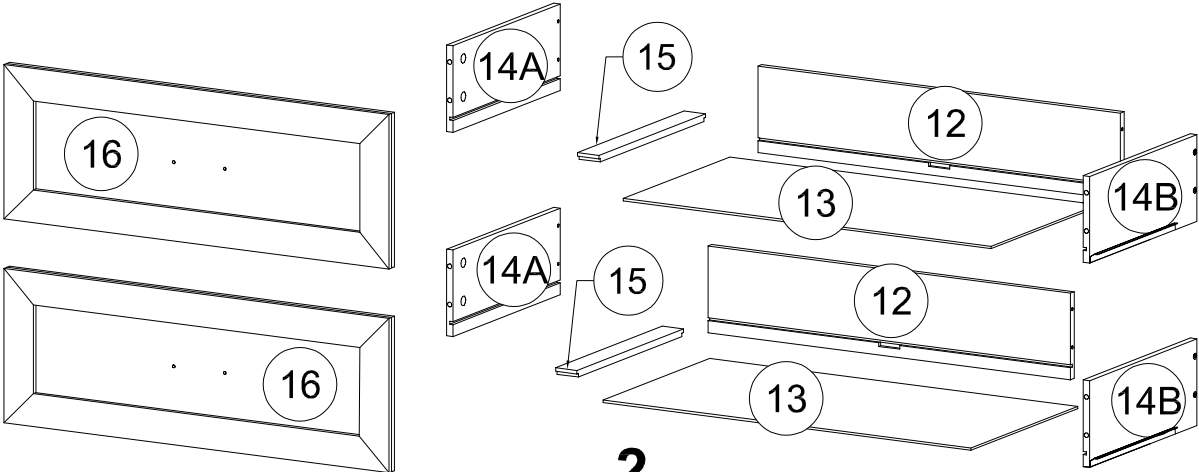

# ASSEMBLY INSTRUCTION

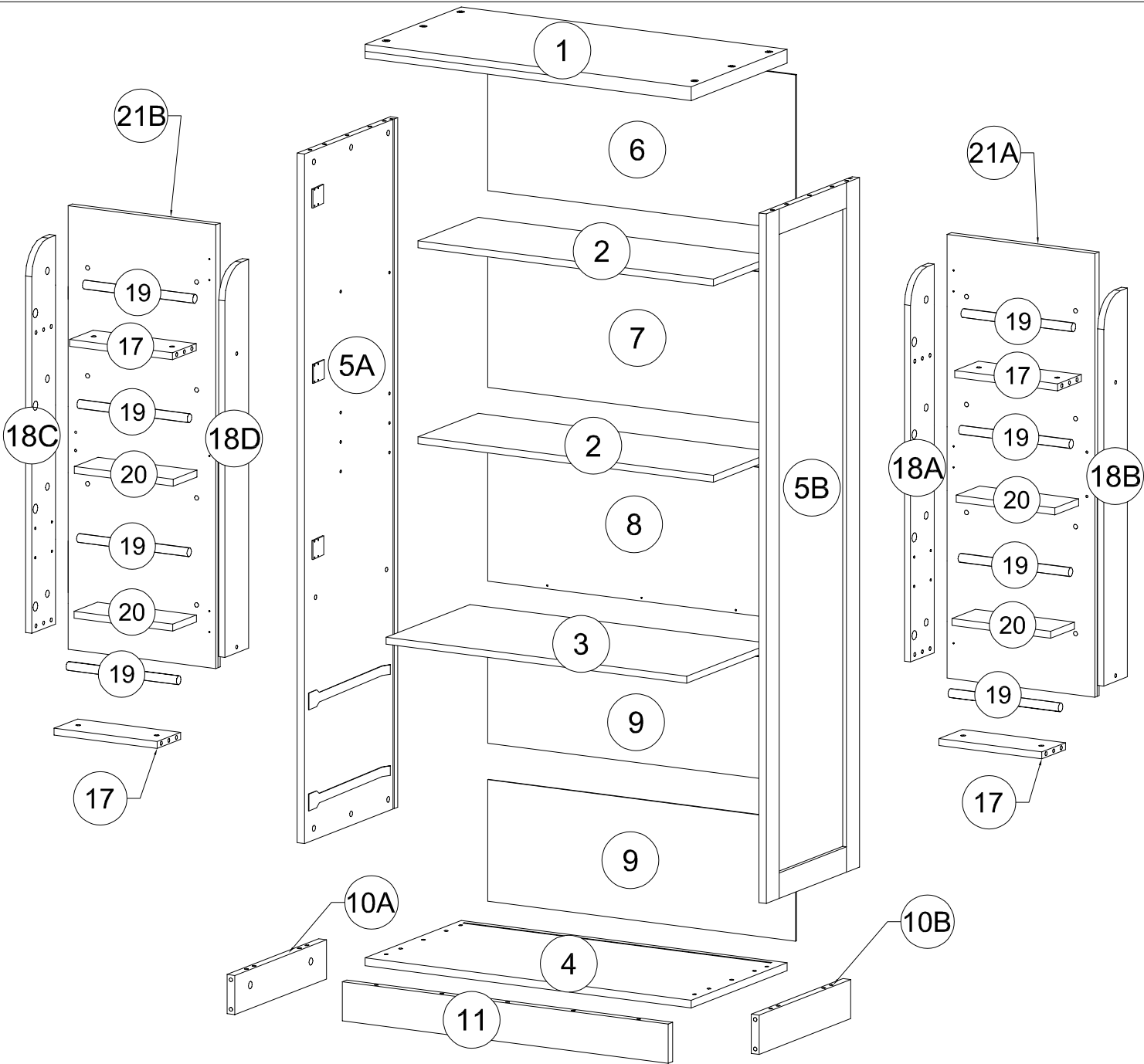

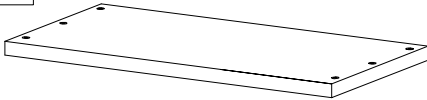
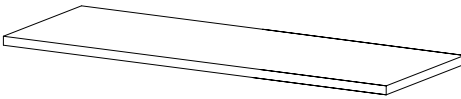
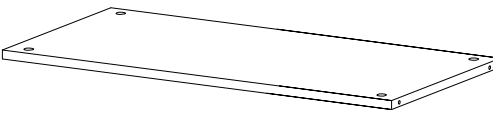
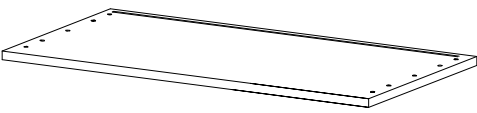
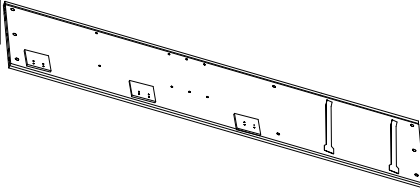
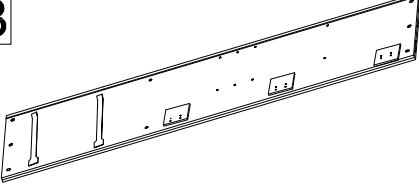
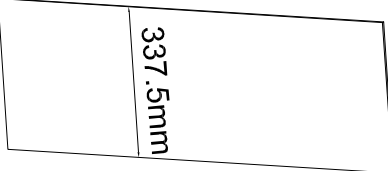
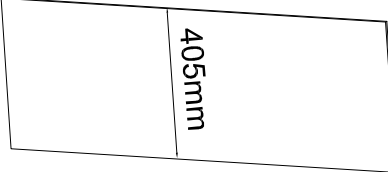
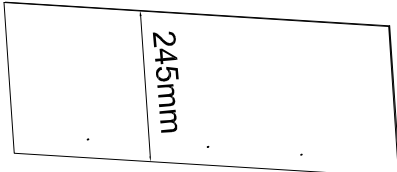
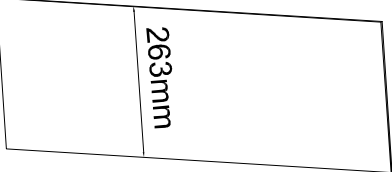
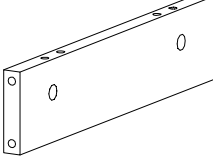
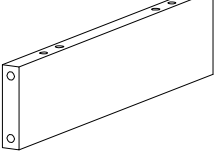
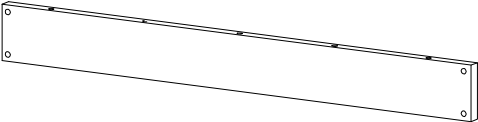
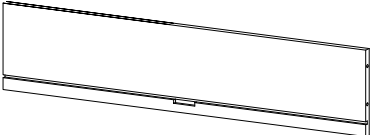
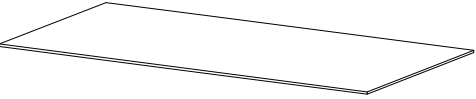
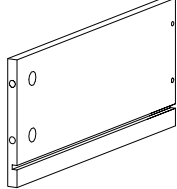
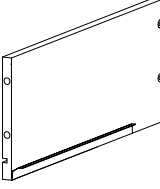
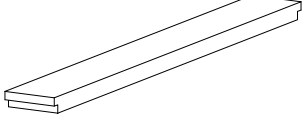
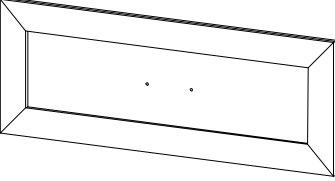
# Part List

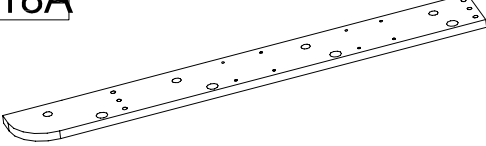
<p><b>1</b></p>  <p>The Top Of The Cabinet - 1pc</p>	<p><b>2</b></p>  <p>Moving Shelves - 2pcs</p>	<p><b>3</b></p>  <p>Fixed Shelf - 1pc</p>
<p><b>4</b></p>  <p>Cabinet Bottom - 1 pc</p>	<p><b>5A</b></p>  <p>Side Edge Of Cabinet - 1pc</p>	<p><b>5B</b></p>  <p>Side Edge Of Cabinet - 1pc</p>
<p><b>6</b></p>  <p>Cabinet Back - 1pc</p>	<p><b>7</b></p>  <p>Cabinet Back - 1pc</p>	<p><b>8</b></p>  <p>Cabinet Back - 1pc</p>
<p><b>9</b></p>  <p>Cabinet Back - 2pcs</p>	<p><b>10A</b></p>  <p>Short bar - 1pc</p>	<p><b>10B</b></p>  <p>Short bar - 1pc</p>
<p><b>11</b></p>  <p>Short bar - 1pc</p>	<p><b>12</b></p>  <p>Drawer - Back Panels - 2pcs</p>	<p><b>13</b></p>  <p>Panel - 2pcs</p>
<p><b>14A</b></p>  <p>Drawer - Side Panels - 2pcs</p>	<p><b>14B</b></p>  <p>Drawer - Side Panels - 2pcs</p>	<p><b>15</b></p>  <p>Drawers - Support Bottom - 2pcs</p>
<p><b>16</b></p>  <p>Drawer - Front Panels - 2pcs</p>	<p><b>17</b></p>  <p>Fixed Shelf - 4pcs</p>	<p><b>18A</b></p>  <p>Standing Bar Shelf - 1pc</p>

# Part List

18B

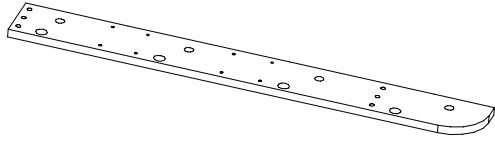

Standing Bar Shelf - 1pc

18C

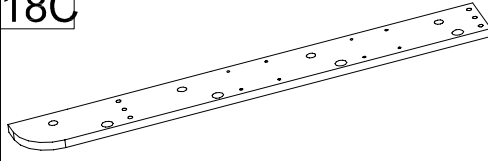

Standing Bar Shelf - 1pc

18D

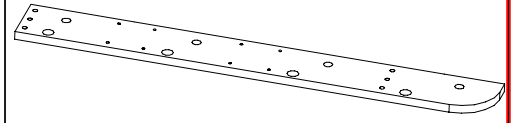

Standing Bar Shelf - 1pc

19

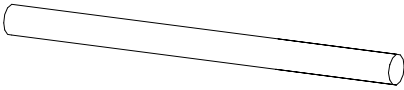

Round Bar Shelf - 8pcs

20

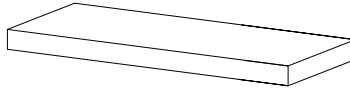

Moving Shelves - 4pcs

21A

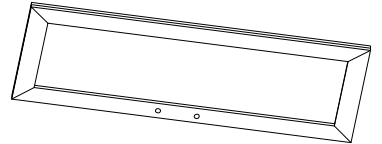





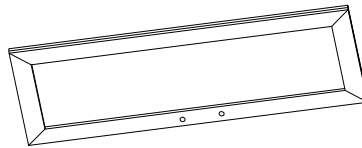

Cabinet Wings - 1 pc

21B

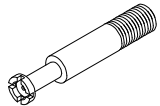

Cabinet Wings - 1 pc

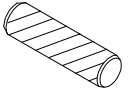
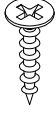
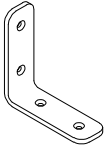
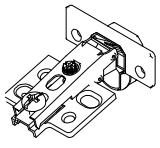
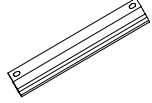
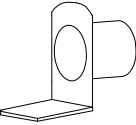
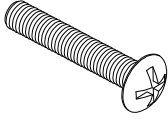
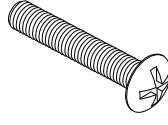
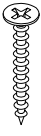
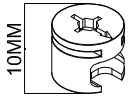
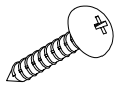
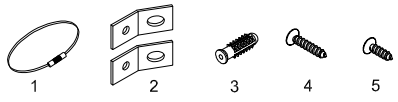

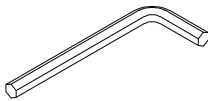
# Hardware List

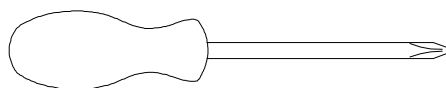
<p><b>A</b></p>  <p>Link 1 - 47 pcs</p>	<p><b>B</b></p>  <p>Link 2- 12mm - 23 pcs</p>	<p><b>C</b></p>  <p>1/4" x 10mm Horizontal -Hole bolts 8pcs</p>
<p><b>D</b></p>  <p>1/4" x 50mm Hex-Head bolts 8pcs</p>	<p><b>E</b></p>  <p>Ø8 x 30 mm Wood dowel 34pcs</p>	<p><b>F</b></p>  <p>M4 x 15 mm Wood Screws 52pcs</p>
<p><b>G</b></p>  <p>Steel Bracket 2pcs</p>	<p><b>H</b></p>  <p>Hinge - 6pcs</p>	<p><b>R</b></p>  <p>Handle Steel 4pcs</p>
<p><b>J</b></p>  <p>Support Pin 9mm 24pcs</p>	<p><b>K</b></p>  <p>M4 x 12mm Truss Head Wood Screws 4pcs</p>	<p><b>L</b></p>  <p>M4 x 22mm Truss Head Wood Screws 4pcs</p>
<p><b>M</b></p>  <p>M4 x 30 mm Wood Screws 8pcs</p>	<p><b>N</b></p>  <p>Link 2 -10mm - 24 pcs</p>	<p><b>O</b></p>  <p>M4 x 25 mm Wood Screws 27pcs</p>
<p><b>P</b></p>  <p>Anti Fall 2 set</p>	<p><b>Q</b></p>  <p>Steel Bracket 4 pcs</p>	<p><b>S</b></p>  <p>Allen Key 1pc</p>



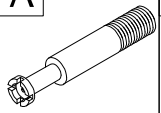

**Assembly Tools Required (Not Included)**

# STEP 1: Following below illustration:

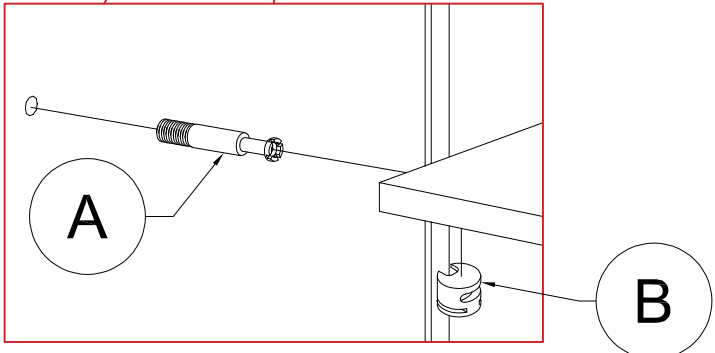
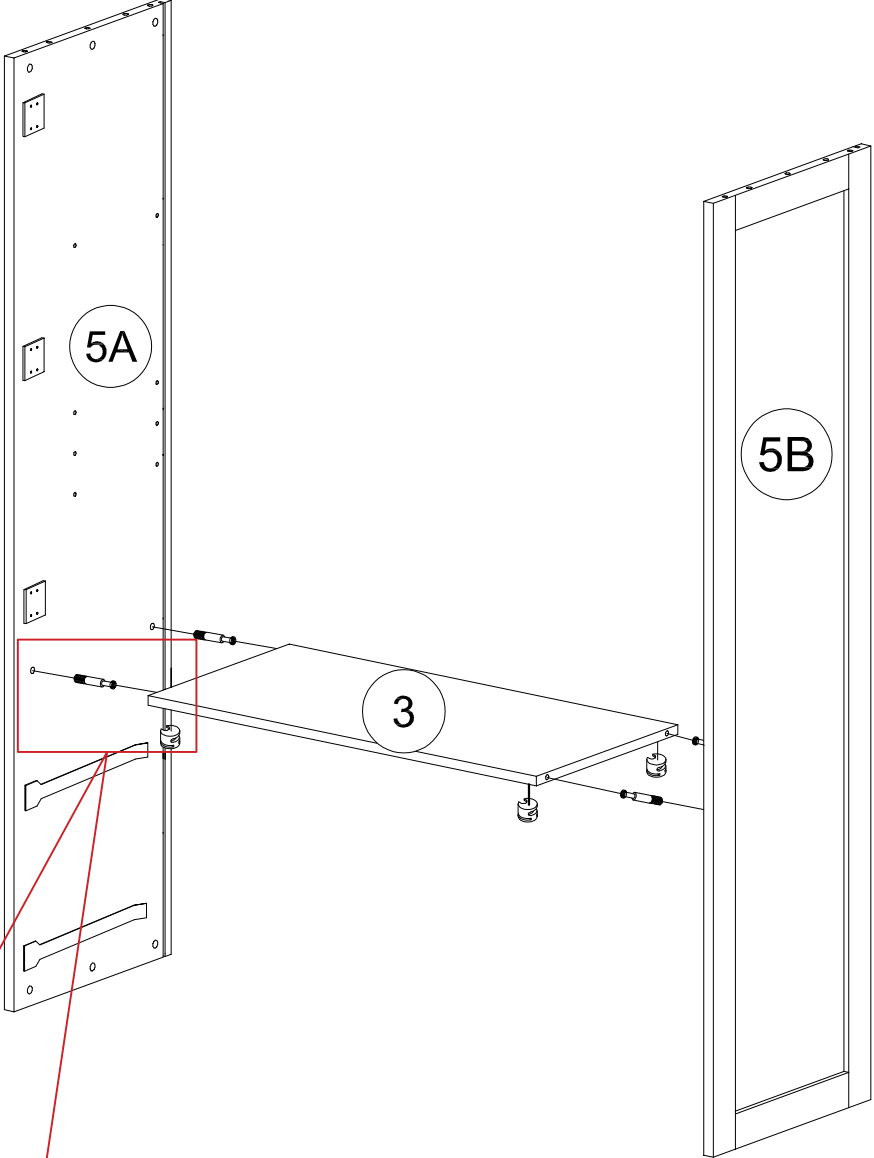
<b>A</b> 	<b>B</b> 
4pcs	4pcs



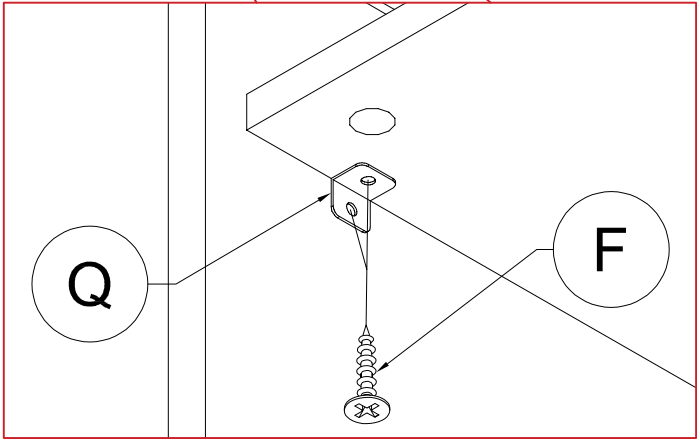
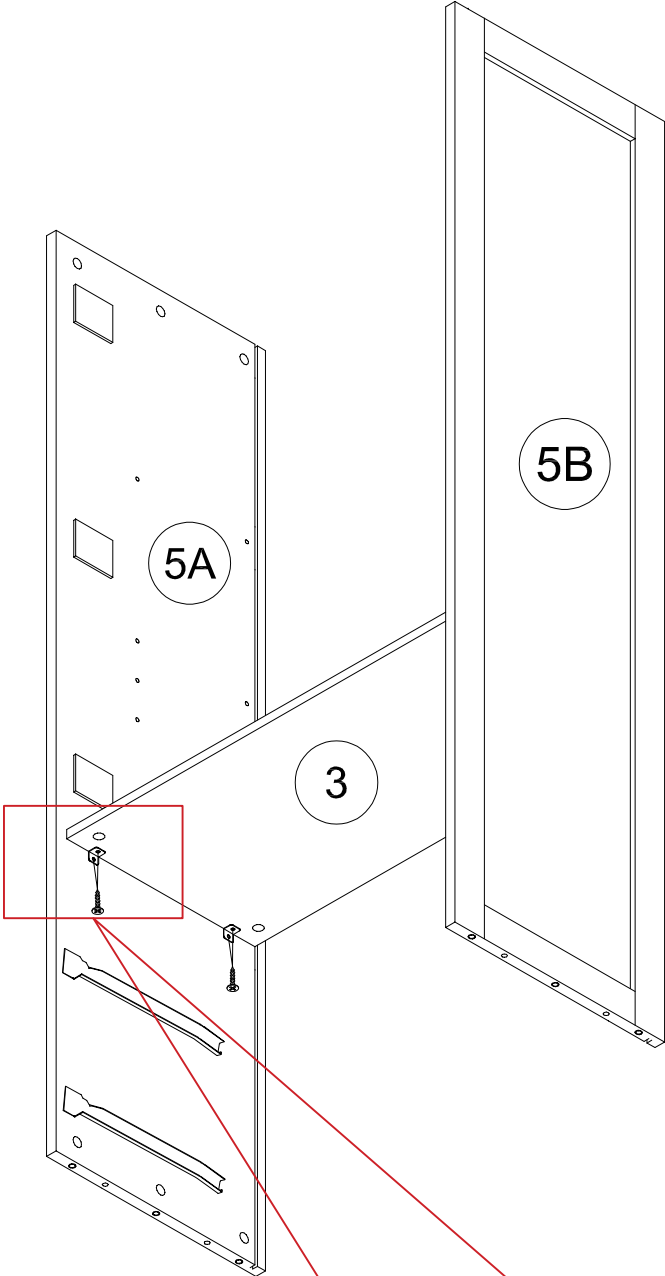

**STEP 2:** Following below illustration:

Q		F	
	4pcs		8pcs



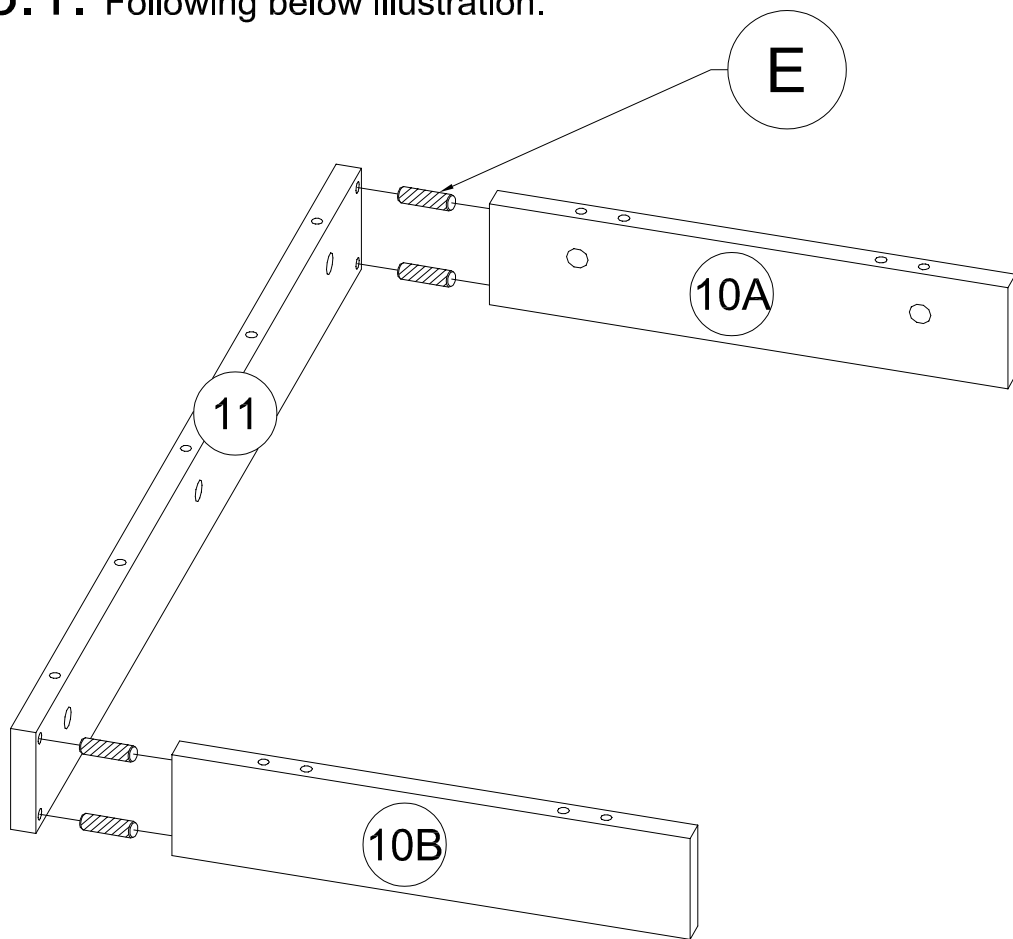

# STEP 3.1: Following below illustration:



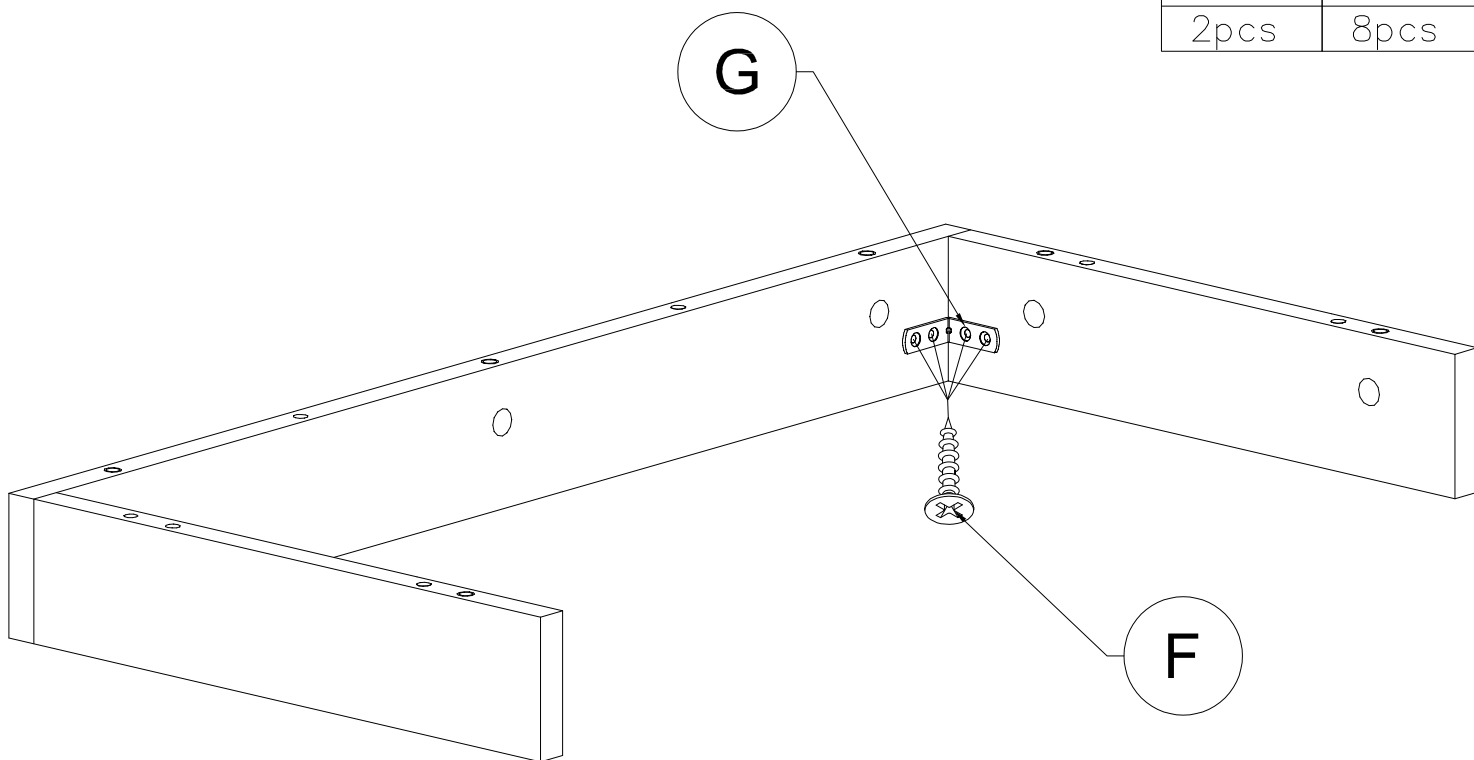

<b>E</b>	
4pcs	

# STEP 3.2: Following below illustration:

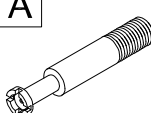

<b>G</b>		<b>F</b>	
2pcs		8pcs	

# STEP 4: Following below illustration:

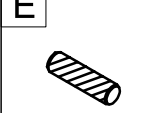
A 	B 	E 
7pcs	7pcs	6pcs

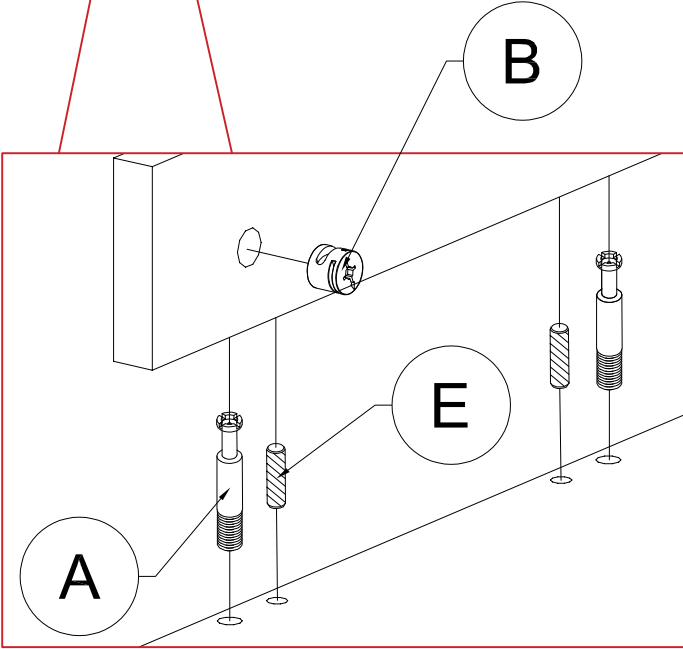
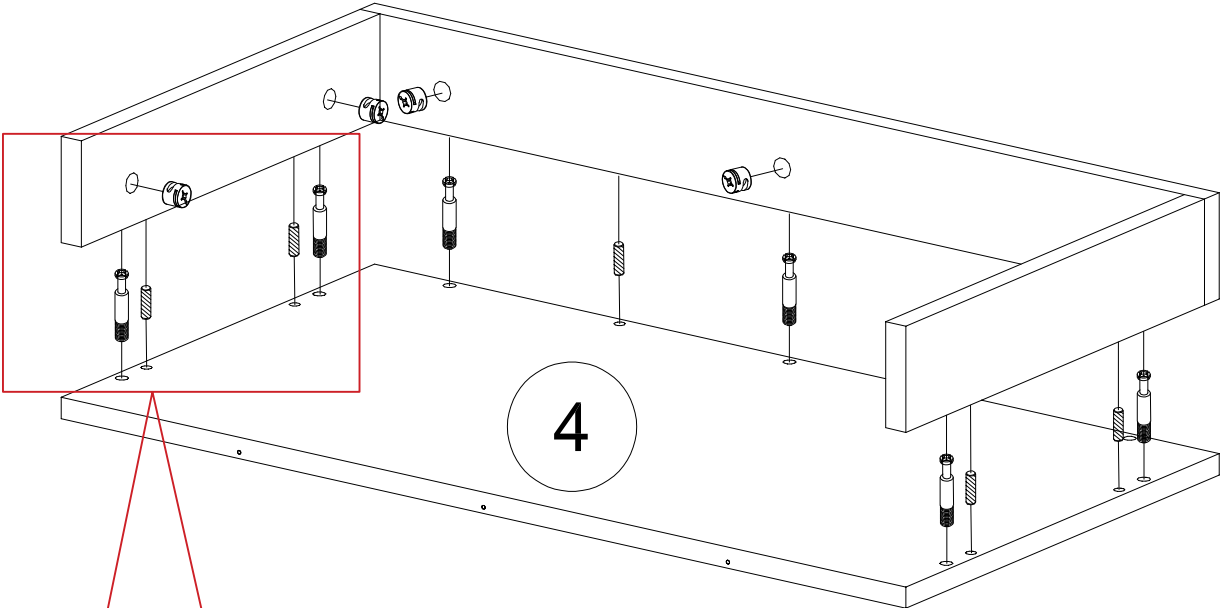

# STEP 5: Following below illustration:

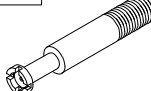
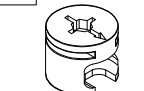
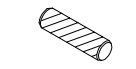
<b>A</b> 	<b>B</b> 	<b>E</b> 
6pcs	6pcs	4pcs

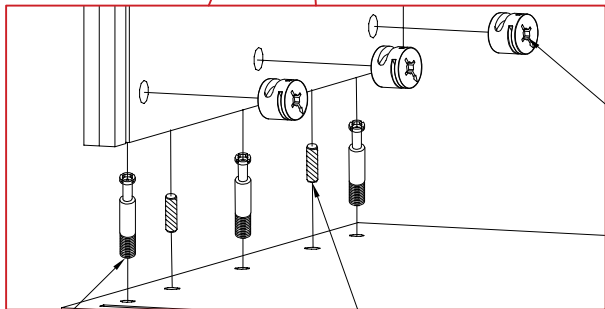
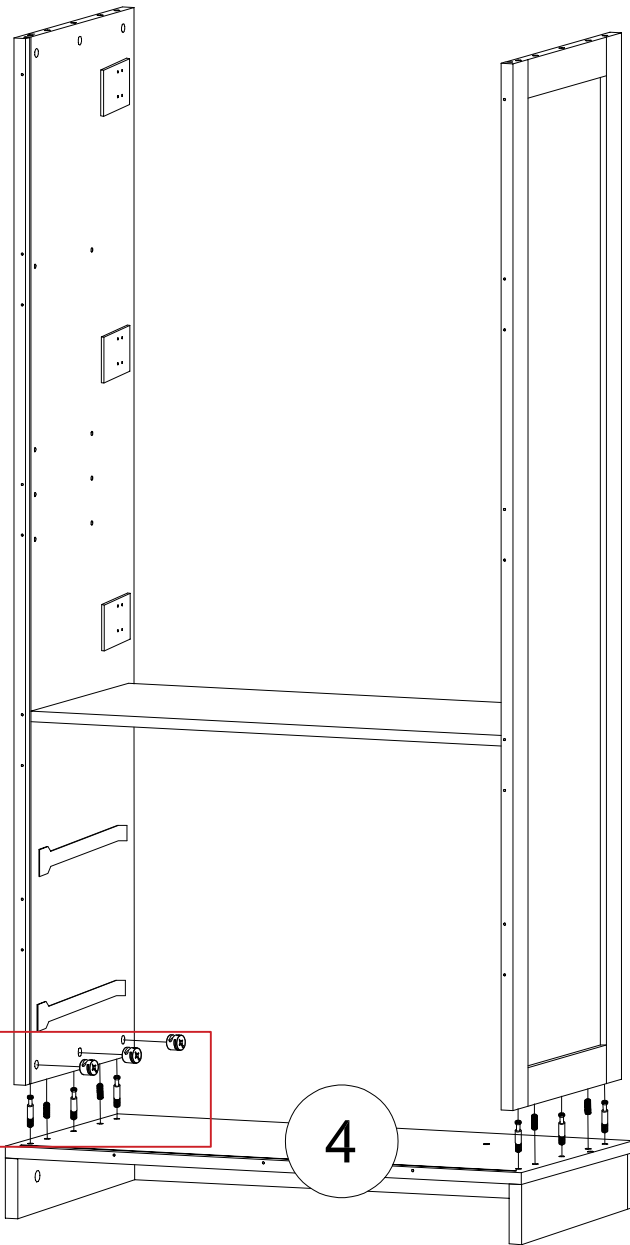

**A**

**B**



**E**

**10**

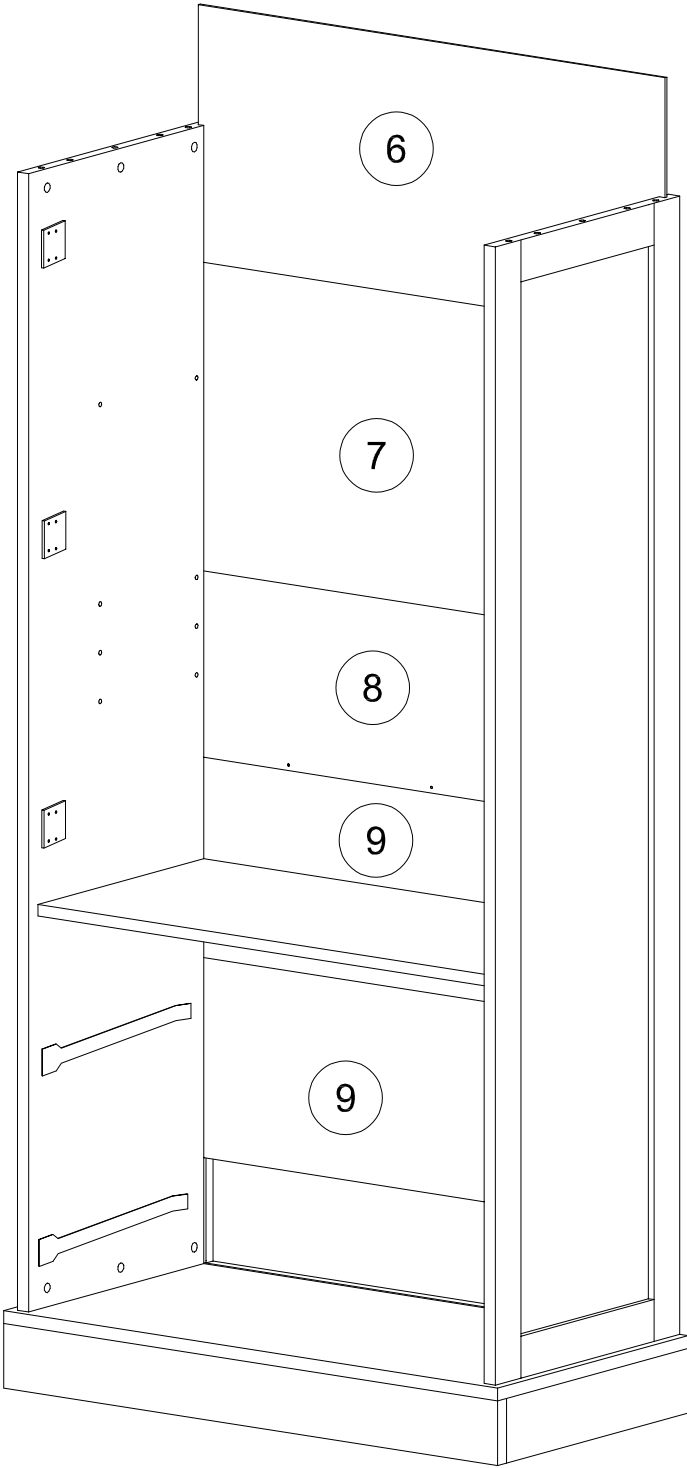
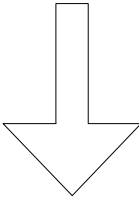
**STEP 6:** Following below illustration:



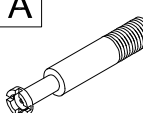
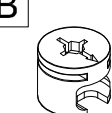

# STEP 7: Following below illustration:

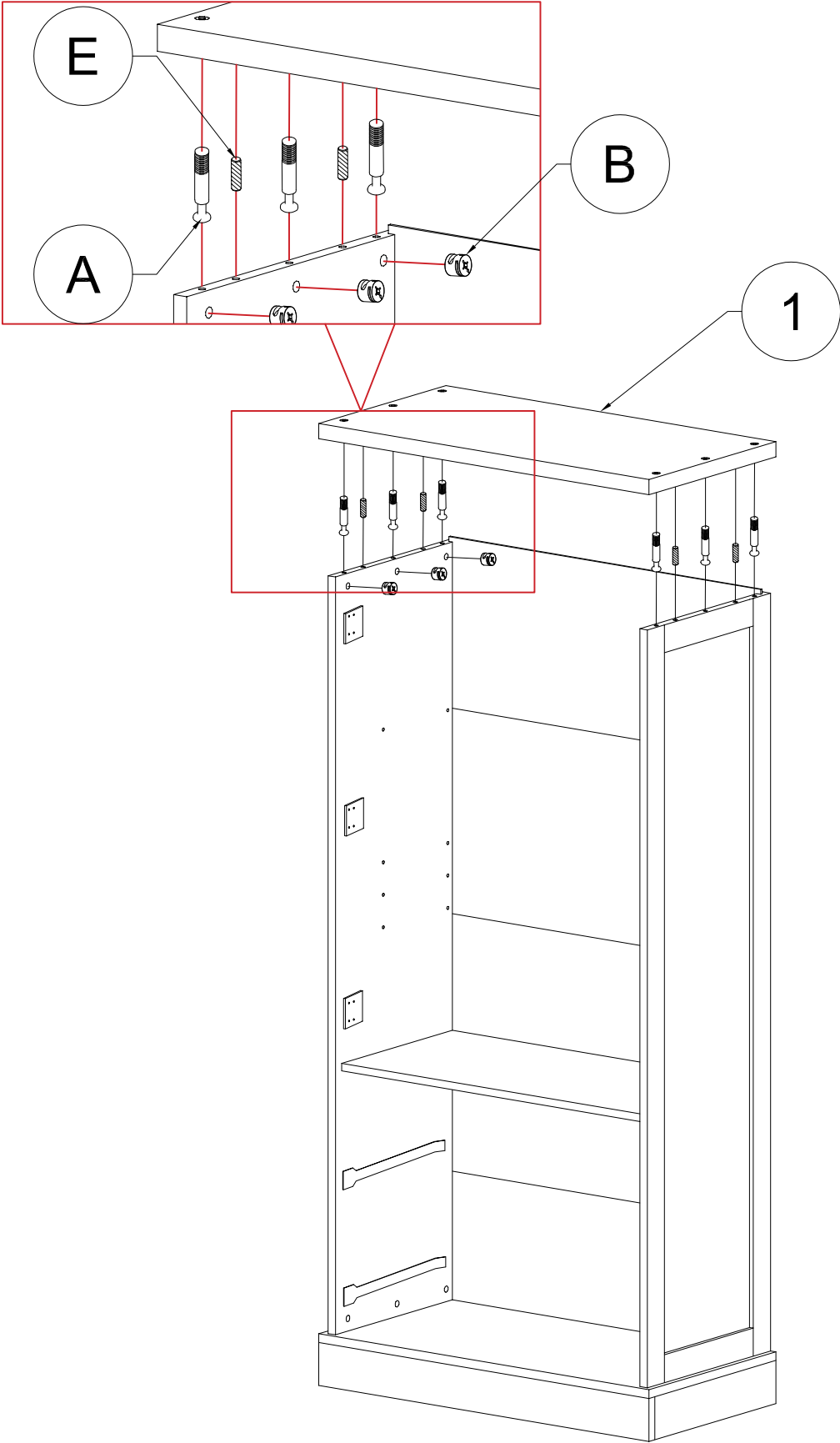
<b>A</b> 	<b>B</b> 	<b>E</b> 
6 pcs	6 pcs	4 pcs

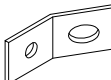

# STEP 8: Following below illustration:

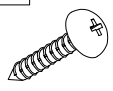

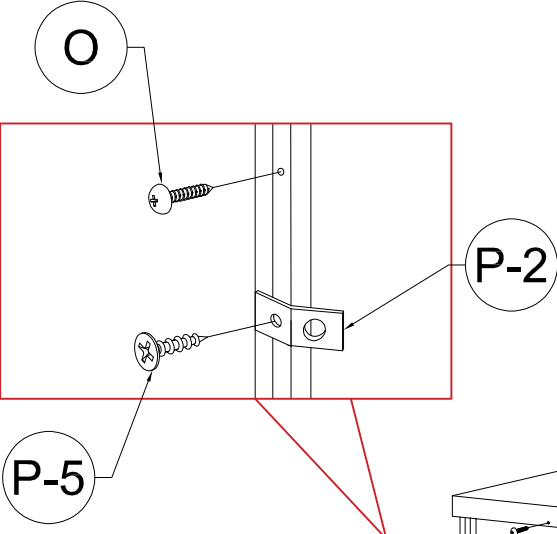
P-2	P-5	O
		
2pcs	2pcs	27pcs

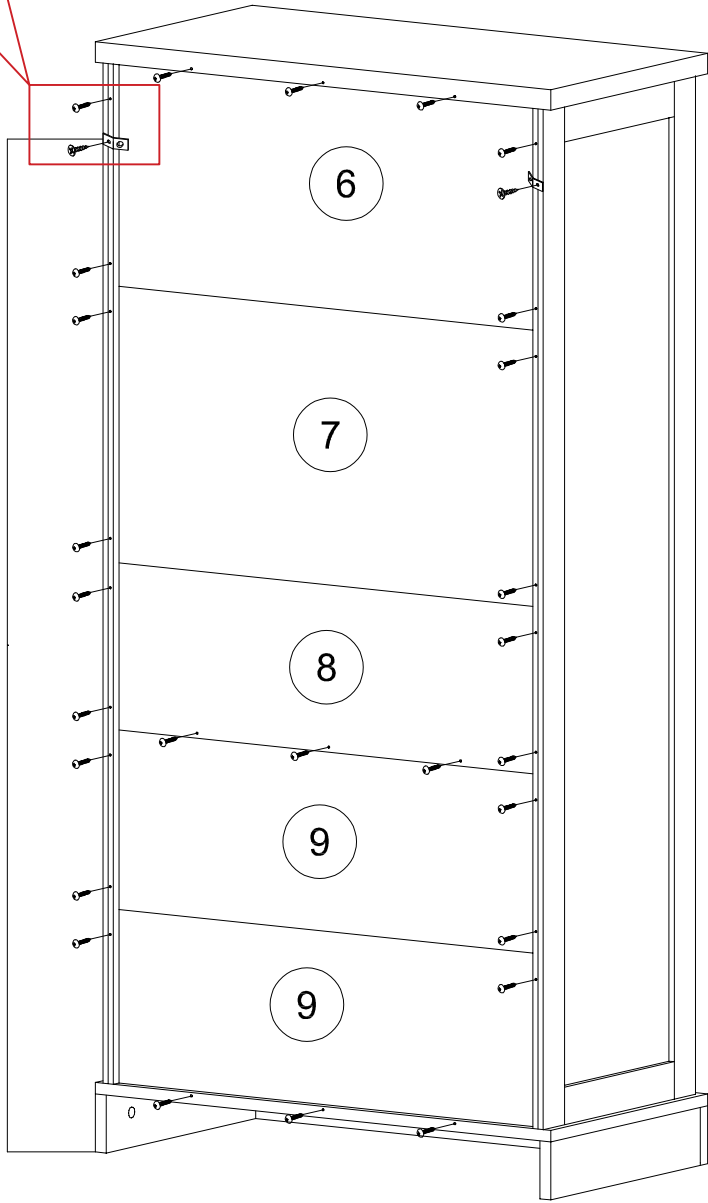

1500MM



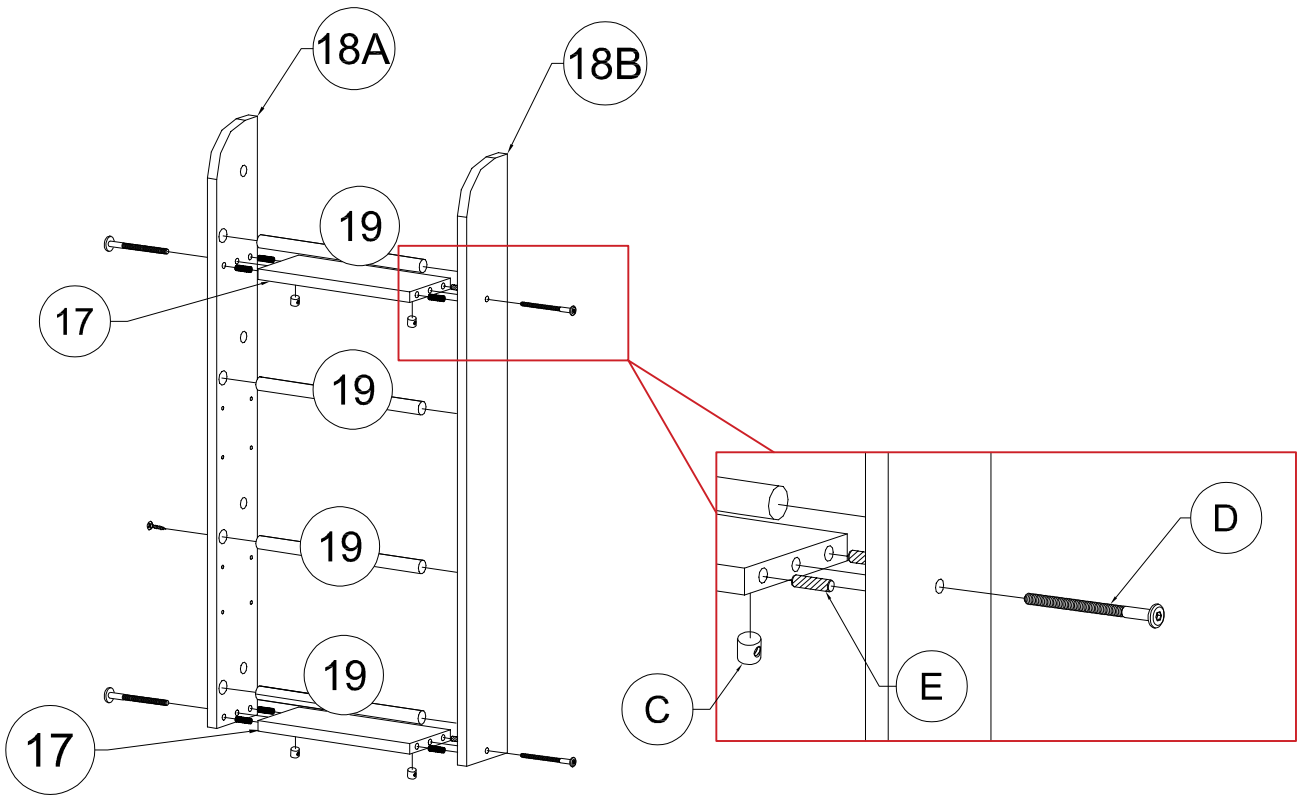

# STEP 9.1: Following below illustration:

D	C	E
		
4pcs	4pcs	8pcs



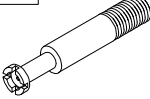

# STEP 9.2: Following below illustration:

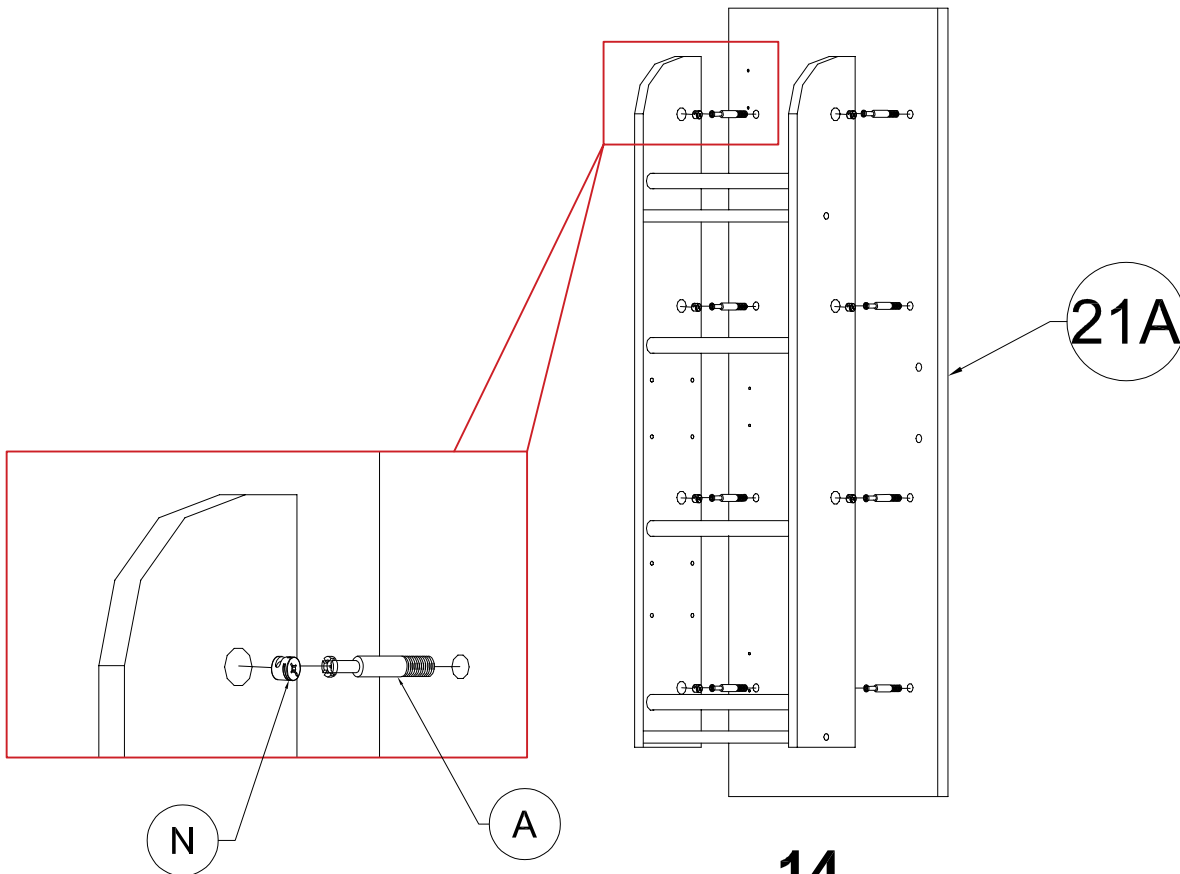
A	N
	
8pcs	8pcs



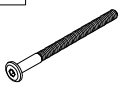

# STEP 10.1: Following below illustration:

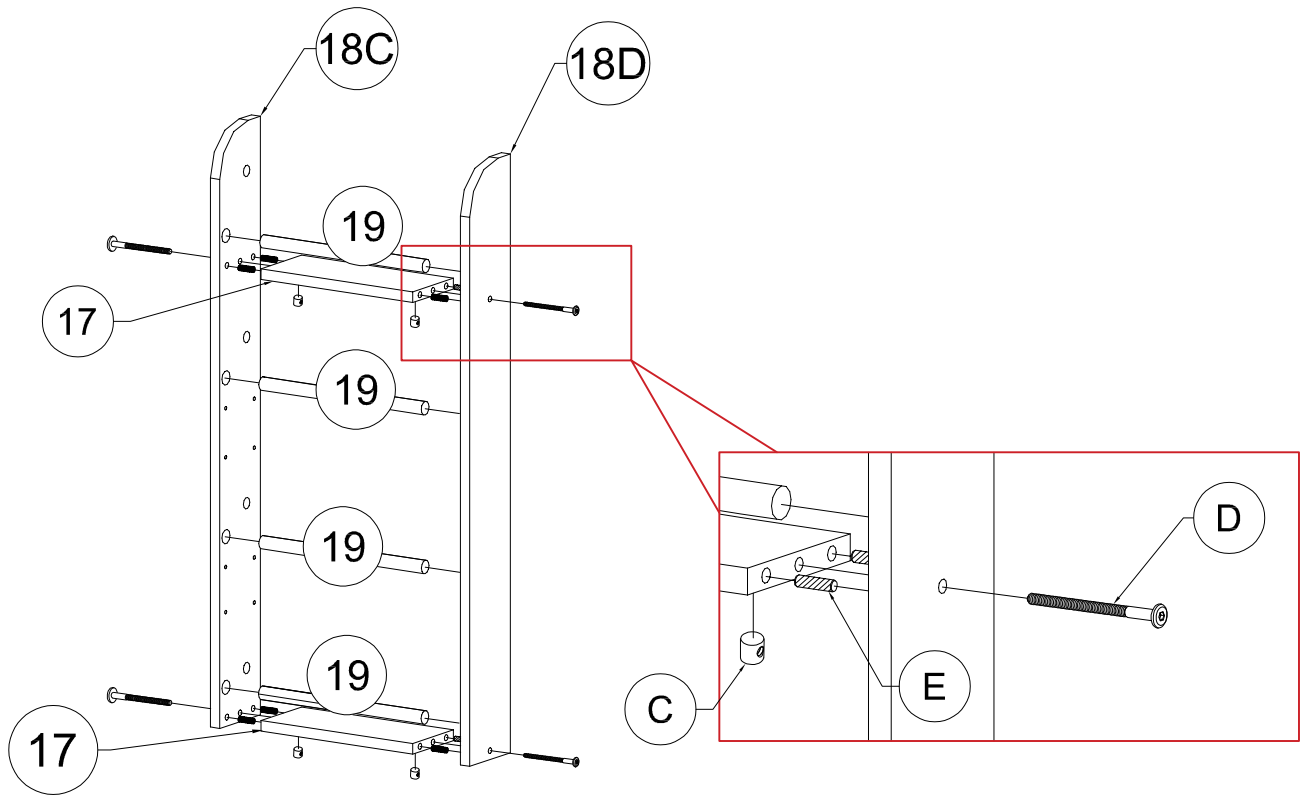
D	C	E
		
4pcs	4pcs	8pcs



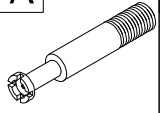

# STEP 10.2: Following below illustration:

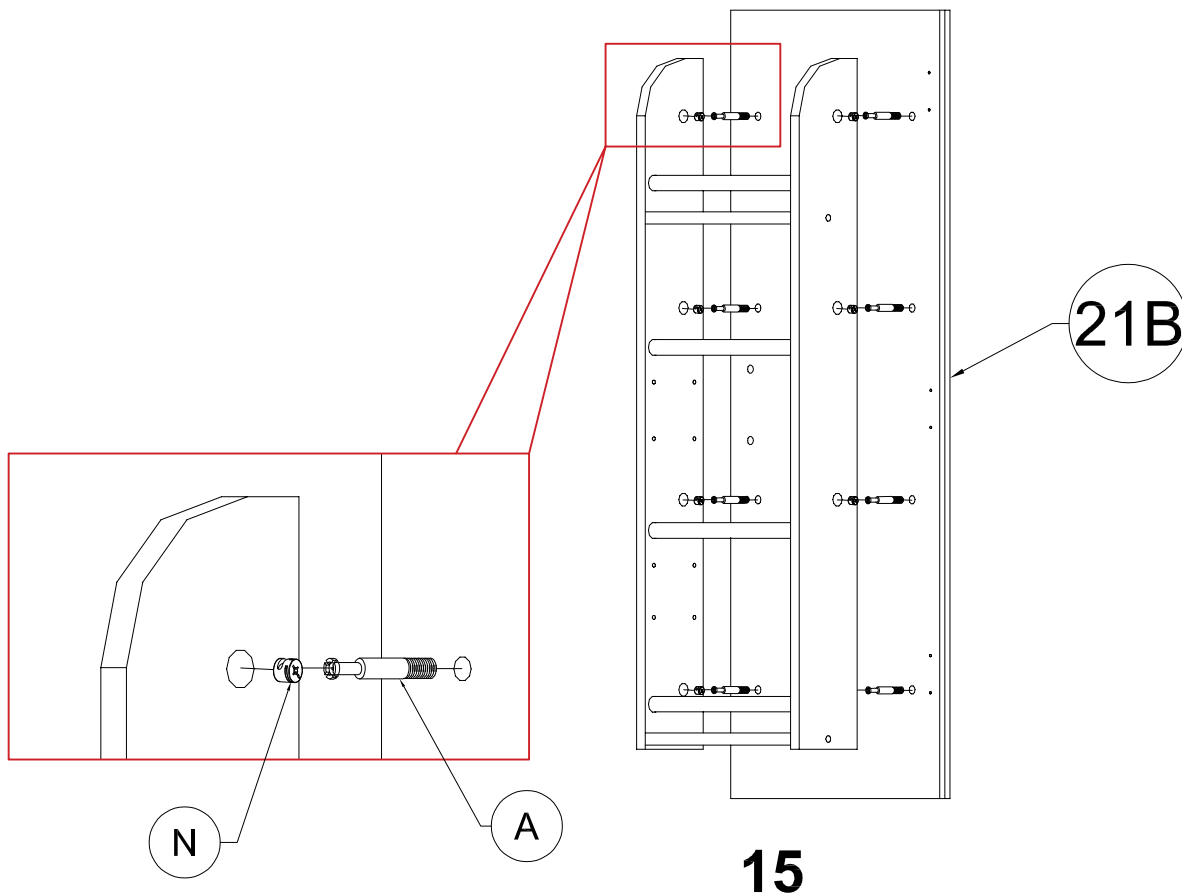
A	N
	
8pcs	8pcs



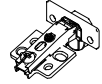

# STEP 11: Following below illustration:

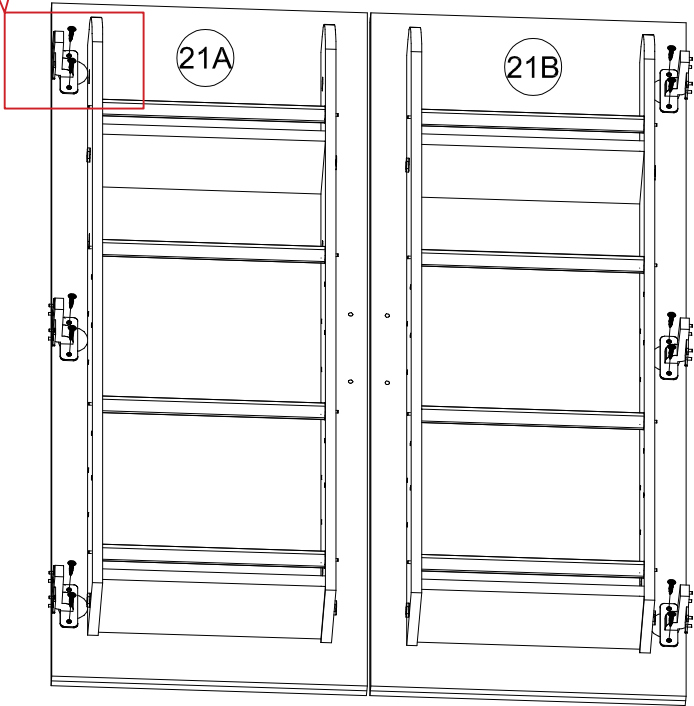
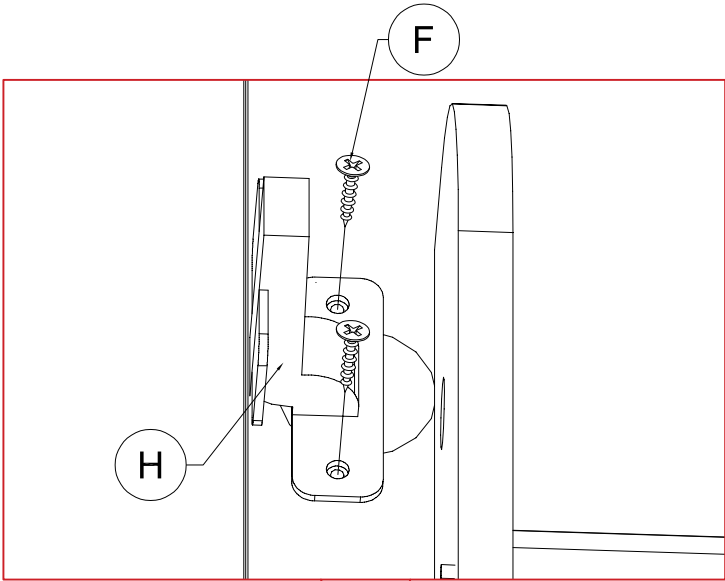
H 	F 
6pcs	12pcs



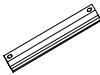
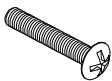

# STEP 12: Following below illustration:

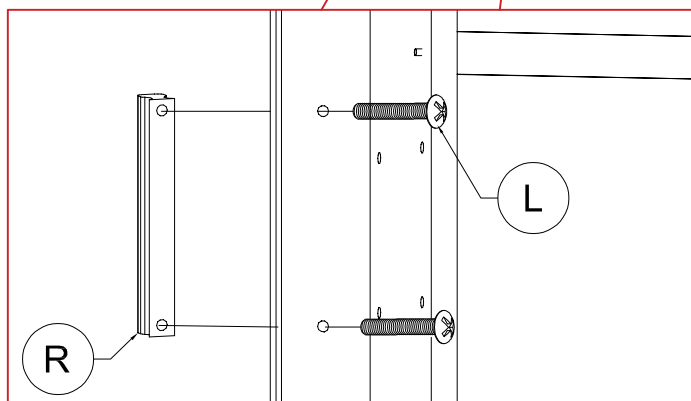
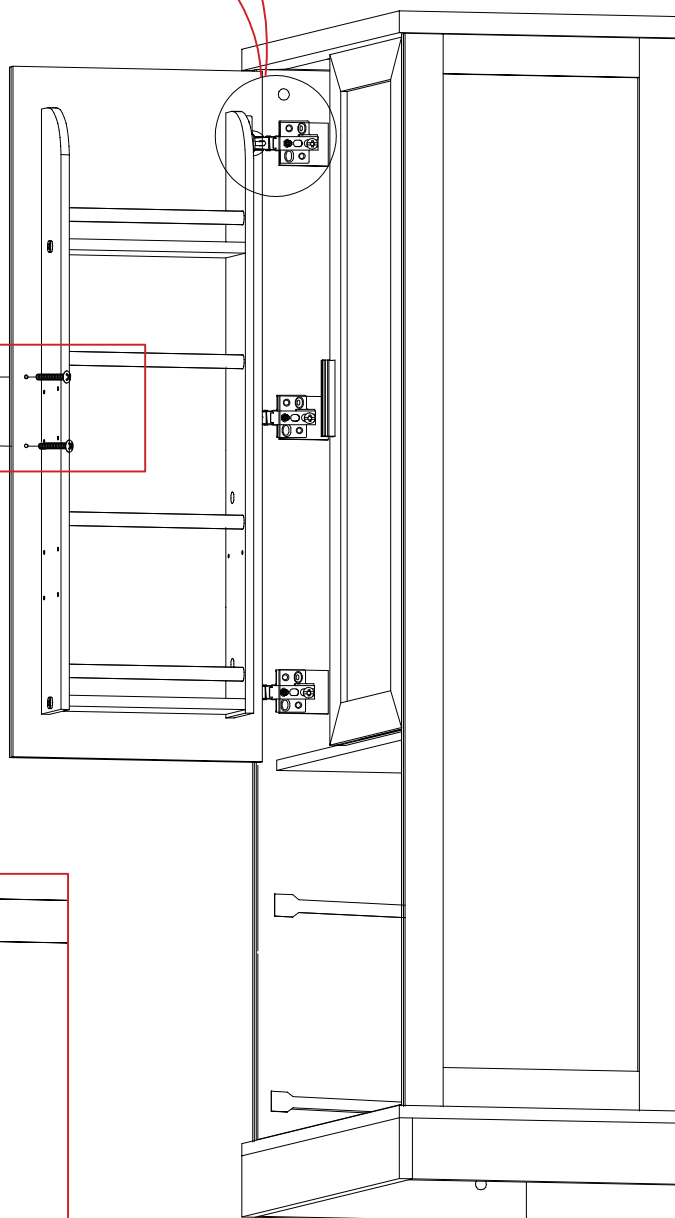
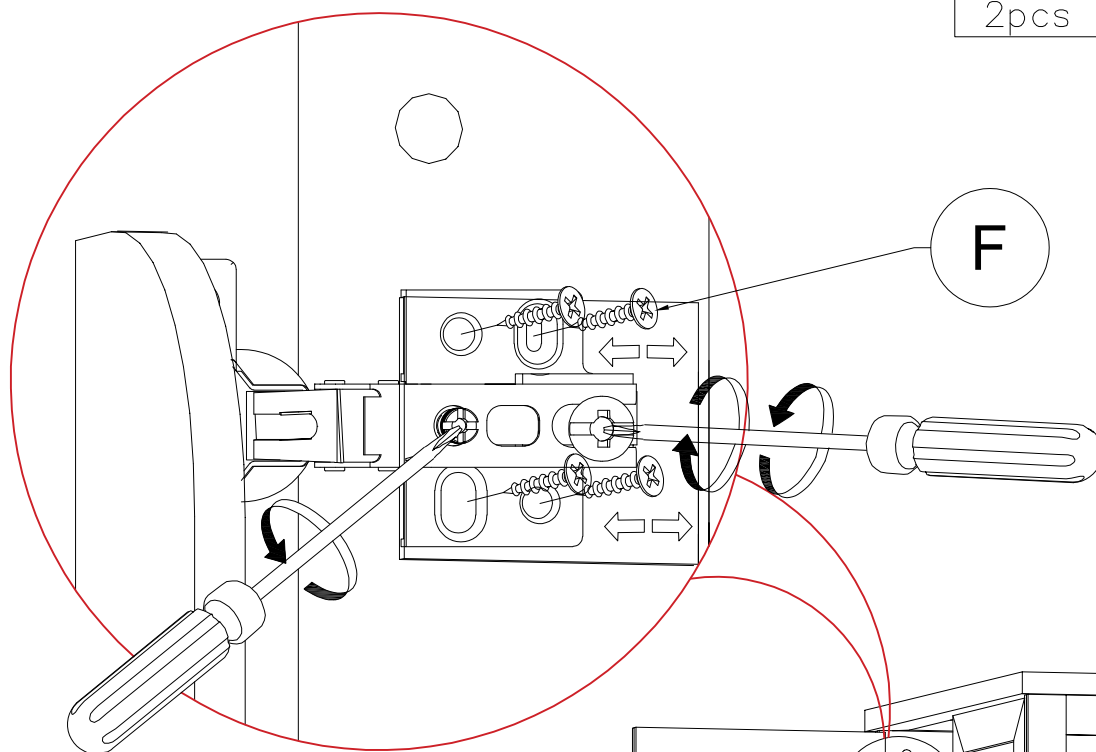
R	L	F
		
2pcs	4pcs	24pcs

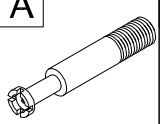

**STEP 13.1:** Following below illustration:

<b>A</b>	<b>N</b>
	
8 pcs	8 pcs

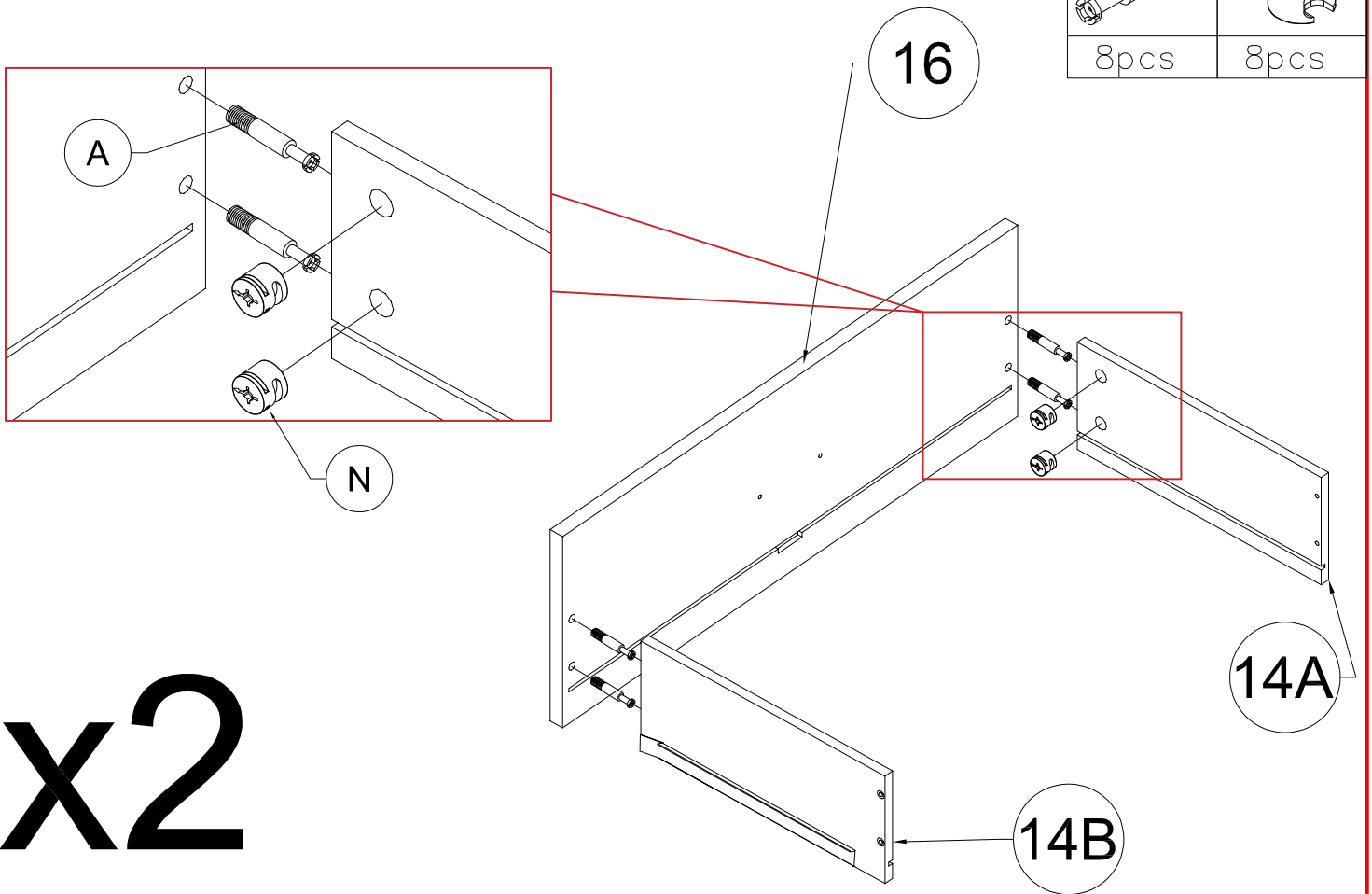

**x2**

**STEP 13.2:** Following below illustration:

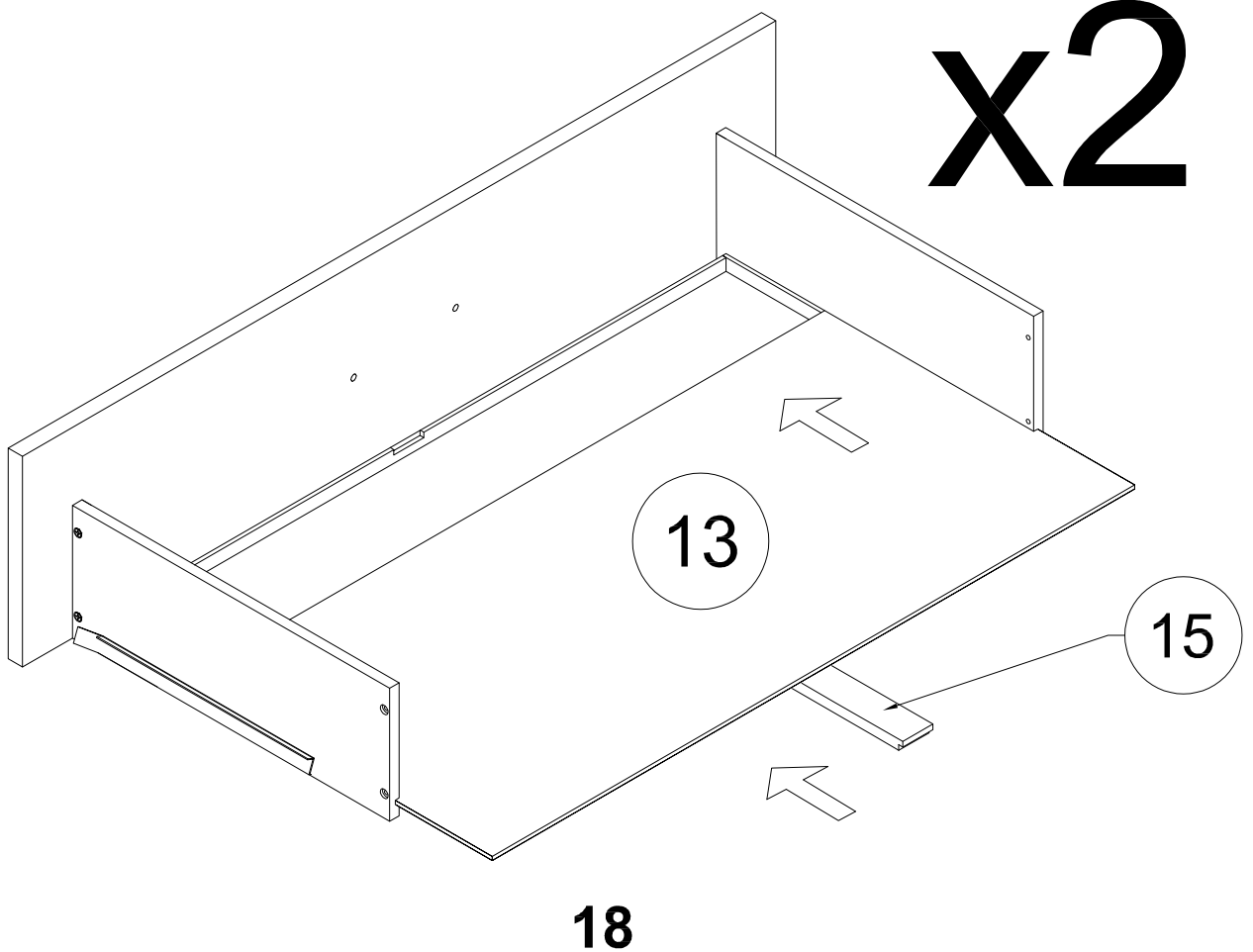

**x2**

**18**

**STEP 14:** Following below illustration:

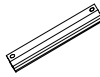
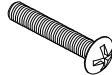
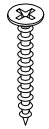
R	K	M
		
2pcs	4pcs	8pcs

R

**x2**

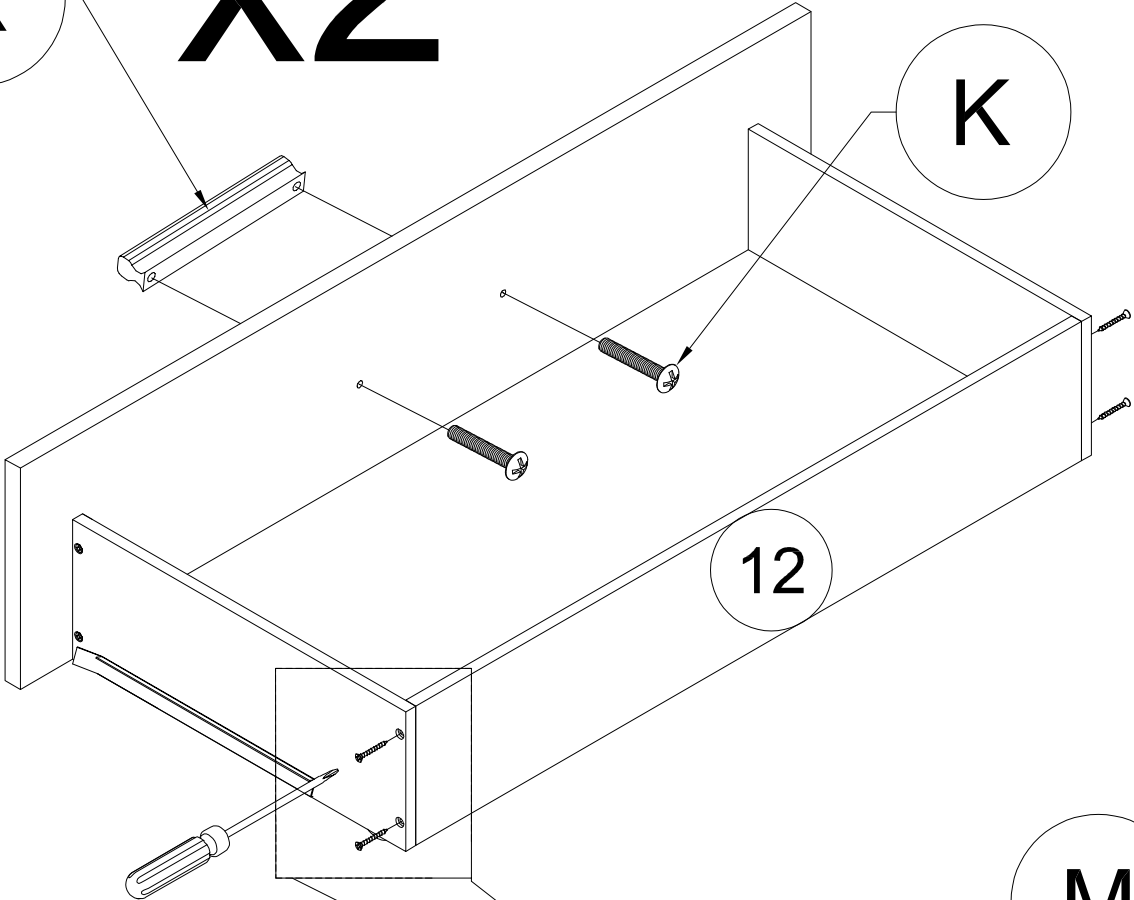

K

12

M

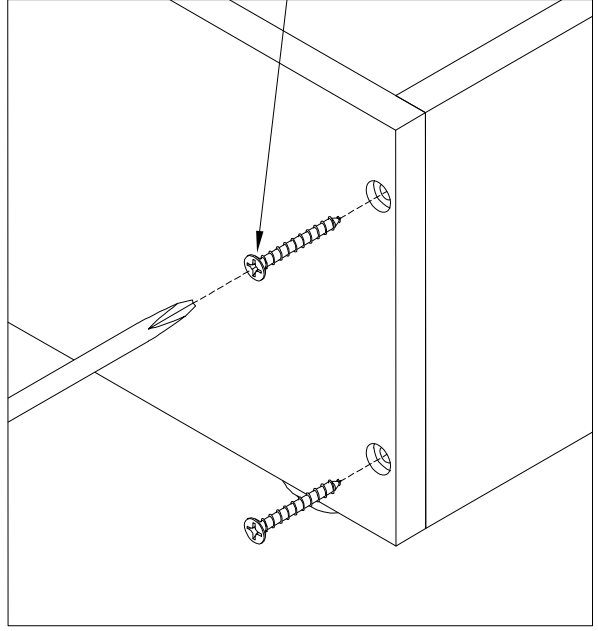

**STEP 15:** Following below illustration:

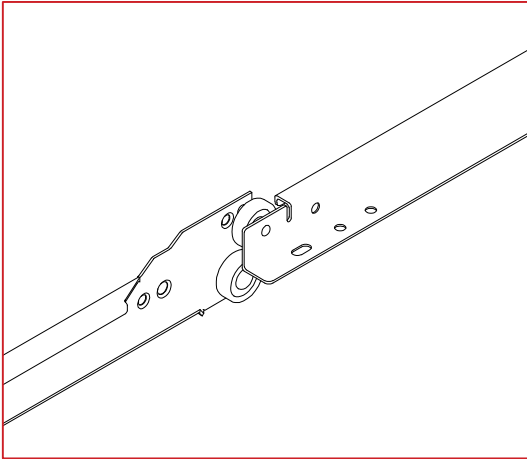
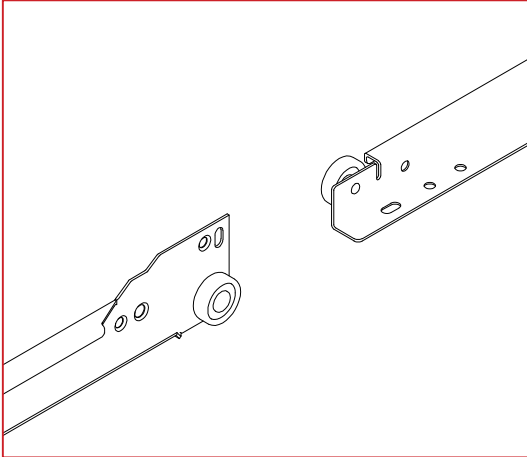

**STEP 16:** Following below illustration:

J



24pcs

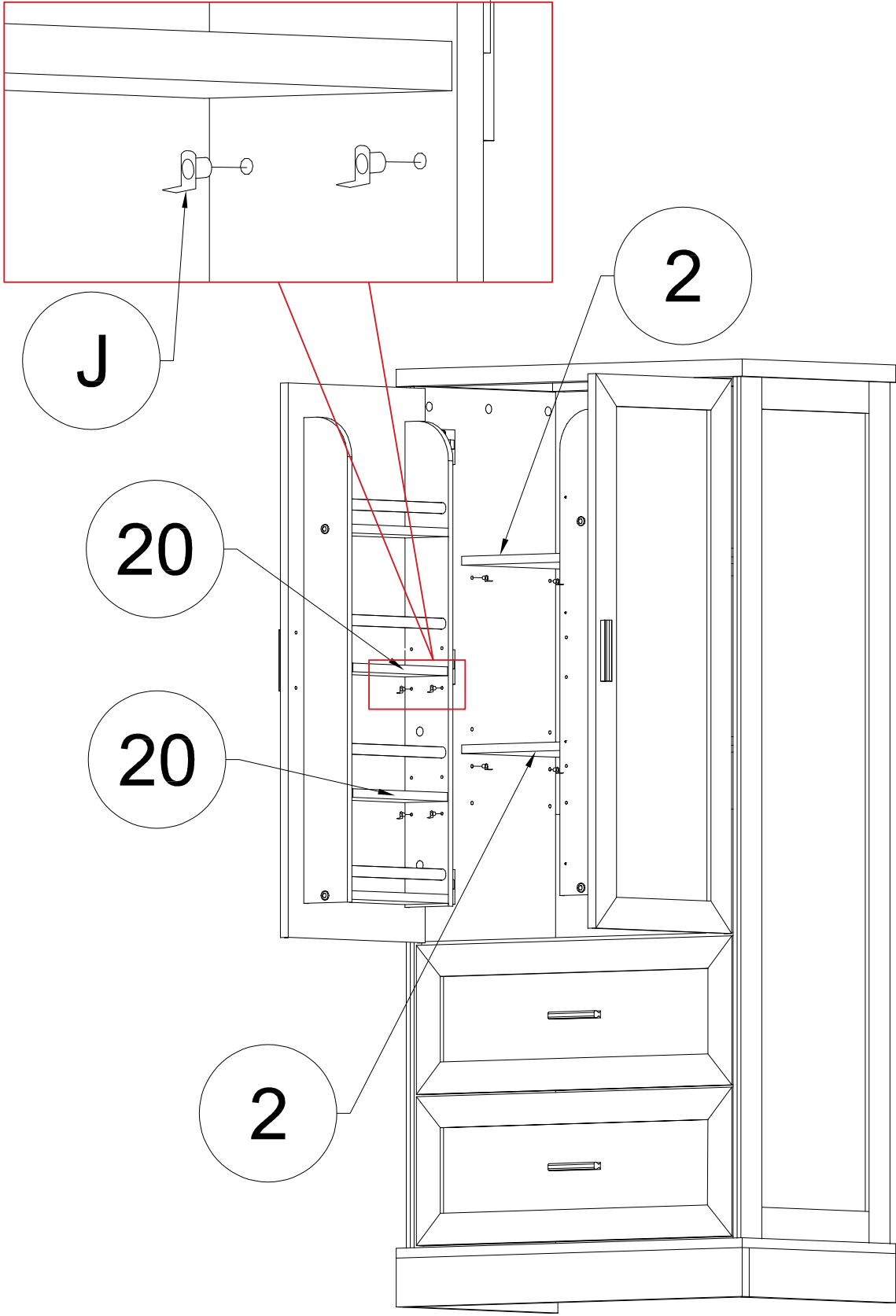

**STEP 17:** Following below illustration:

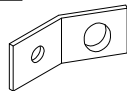
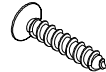
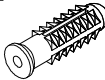
P-2	P-4	P-3
		
2pcs	2pcs	2pcs

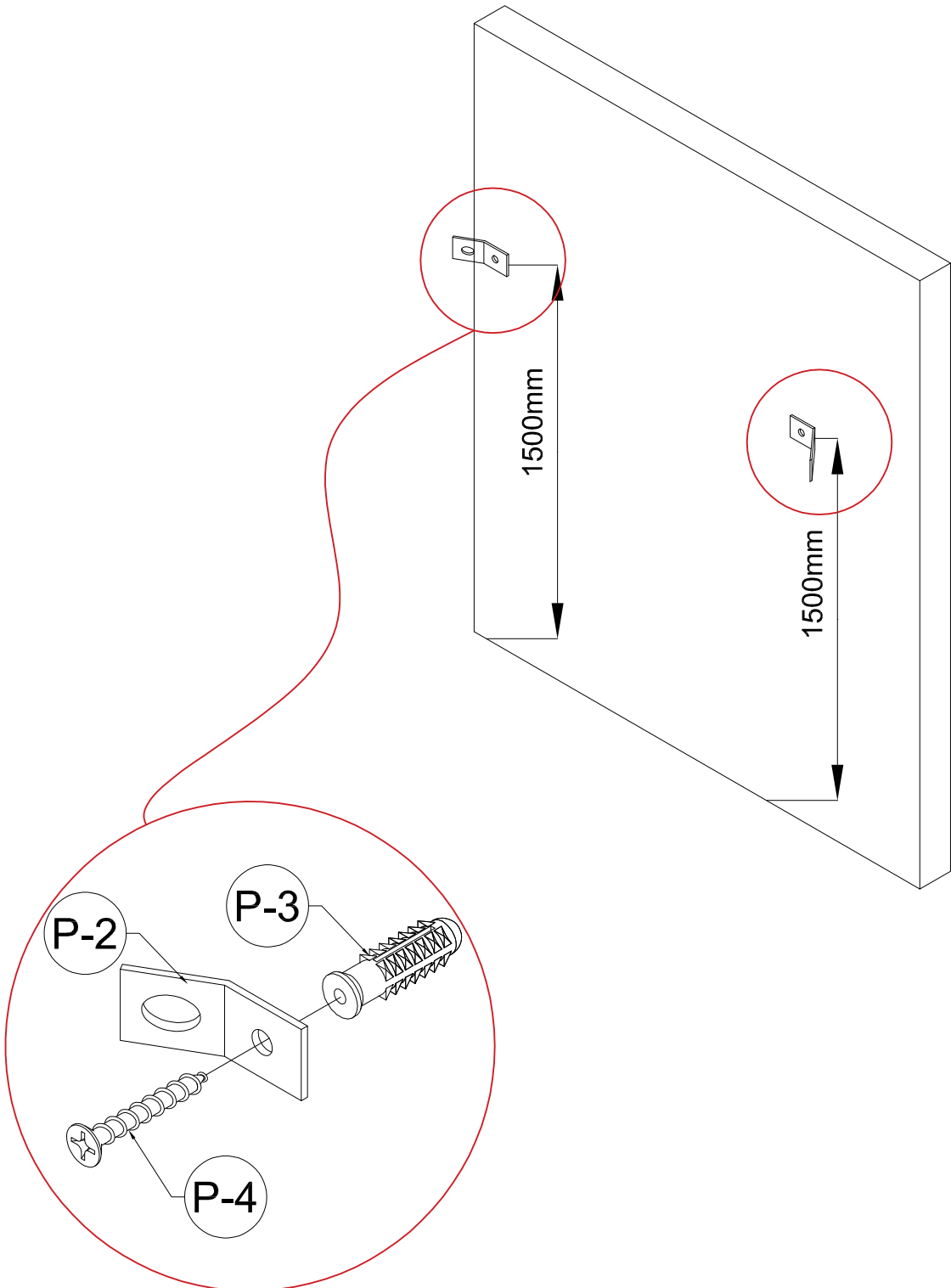

**STEP 18:** Following below illustration:

P-1



2pcs

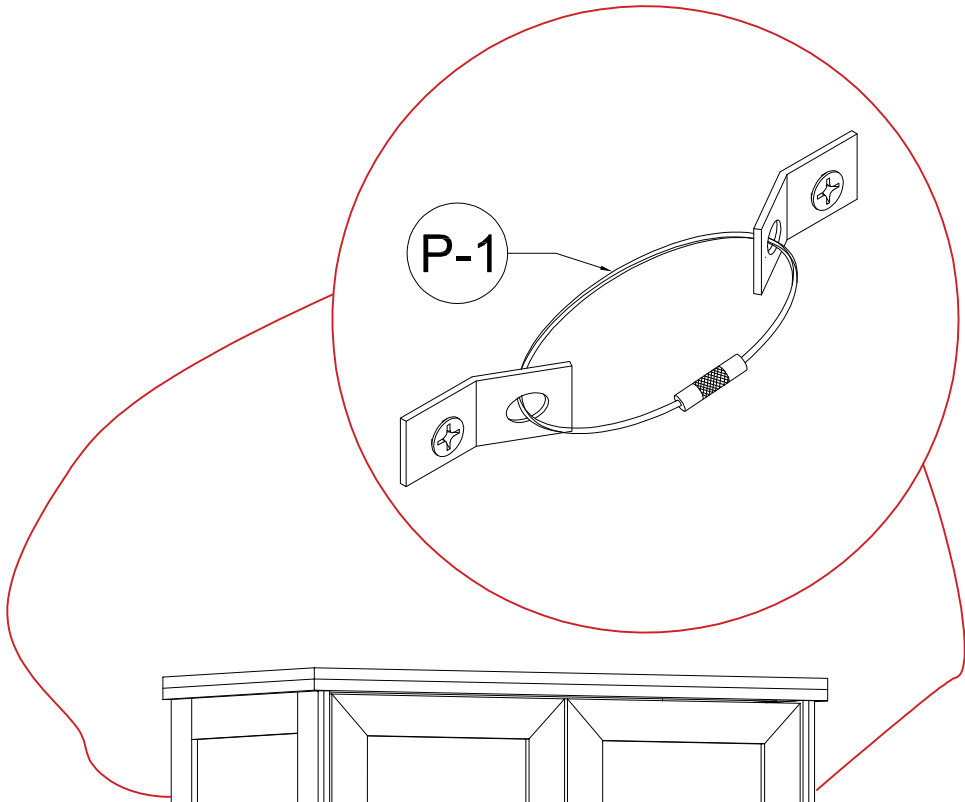

# FINISH

