

Instruction Book

For specification: 80cm(L)x24cm(W)x106cm(H)

SC-2306 instruction manual

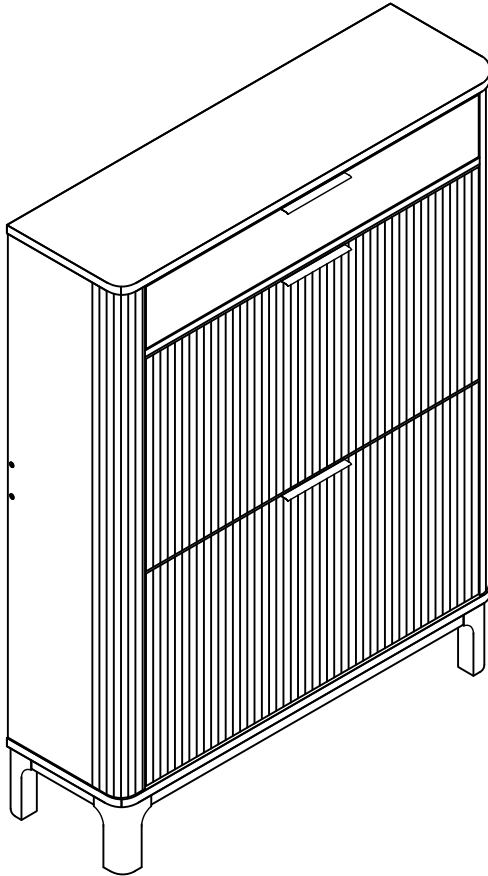

If you have any question, please feel free to contact us by Amazon email Foreword:

Thank you for choosing our product! We hope you have a good shopping experience! We aim to provide a 100% satisfaction product and customer service. If the received product has missing parts or components, arrived damaged, dissatisfaction with the order, or has questions about the assemble, please do not hesitate to contact us. Our customer service will reply within 12 hours.

Specifications:

Product name: Shoe Cabinet

Model: SC-2306

Package

Dimension: 39.4x18.5x7.5in/100x47x19cm

Product Size: 31.5x9.5x41.7in/80x24x106cm







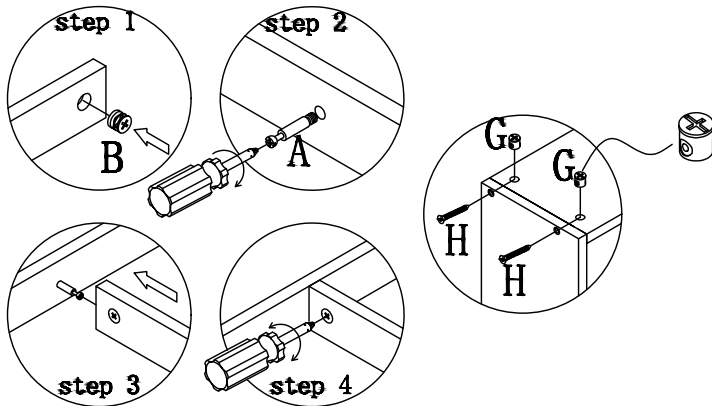

















Weight: 75b/34kg

SC-2306 Left cabinet

A, B, G, H, C, D installation guide



Accessories

 Three-in-one screw A*39	 Three-in-one screw A2*6	 Three-in-one nut B*45	 drawer Track C1*2	 drawer Track C2*2	 Handle E*3
 Two-in-one nut G*4	 Two-in-one screw H*4	 Mu Xiao N*8	 Small Screw X*5	 Small Screw F*4	 Handle Screw V*4
 Small Screw D*16	 Small Screw T*32	 Small Screw Q*6	 Anti dumping device L*2	 Setscrew O*2	 Stool foot nail M*5
 Shoe cabinet tipping frame K*4	 Handle Screw K1*4	 Handle Screw K2*4	 Handle Screw K3*4	 Door stopper K4*4	 screwdriver Z*1

SC-2306

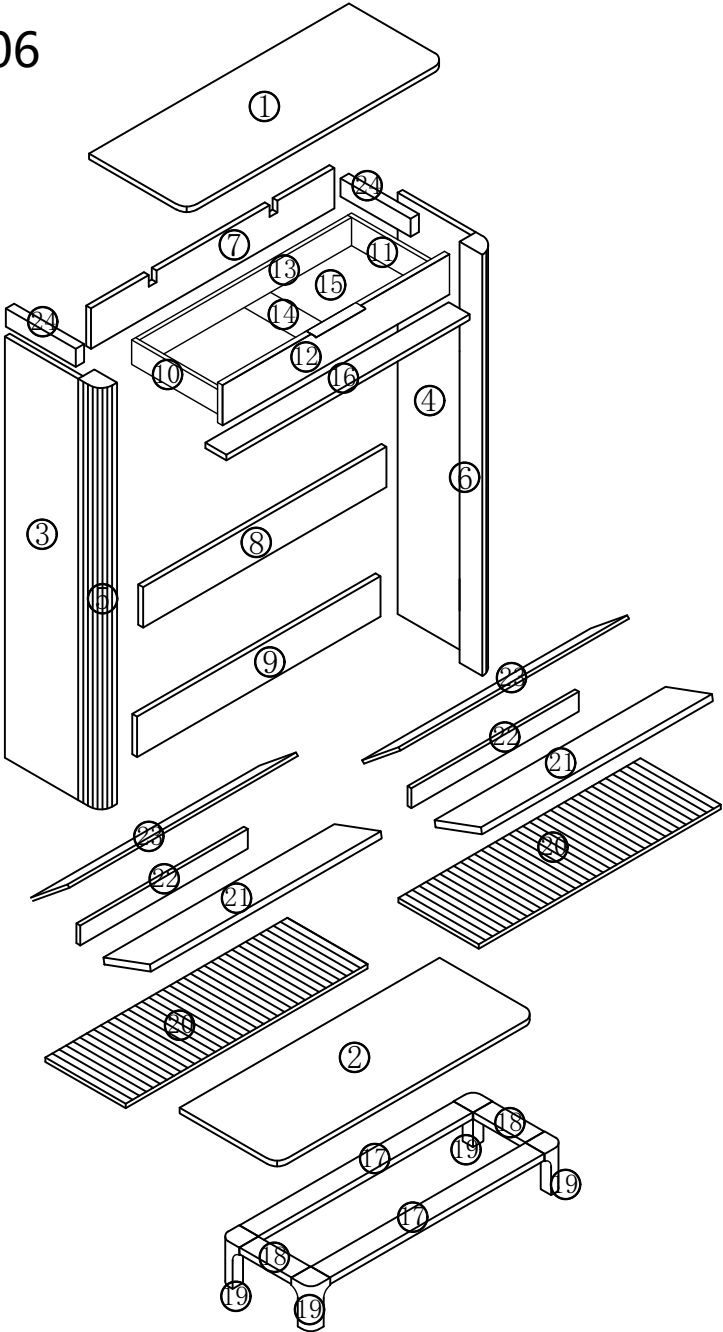

Guidelines for the use of 3-in-1 connecting rods:

The blue screw cap at the bottom of the 3-in-1 connecting rod is twist-able, and it can be twisted clockwise or counterclockwise to fit the size of the reserved holes in the wooden board.

When you use this 3-in-1 connecting rod, if you find that it can't be inserted into the reserved holes on the wooden board, just loosen the blue screw cap a bit until it fits into the holes of the board. Then use a screwdriver to tighten the screws. Note: If the bottom blue screw cap is not stretched apart by the three-in-one connecting rod in the reserved hole, the connected part will appear unstable .

STEP 1

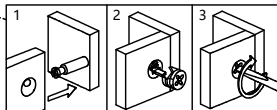
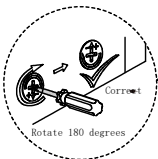
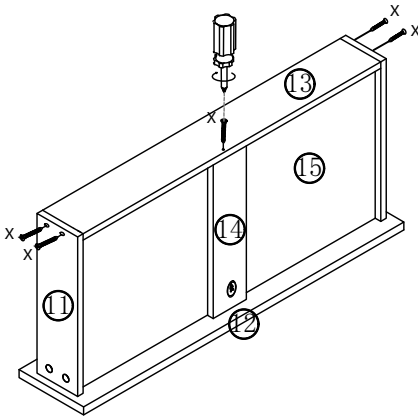
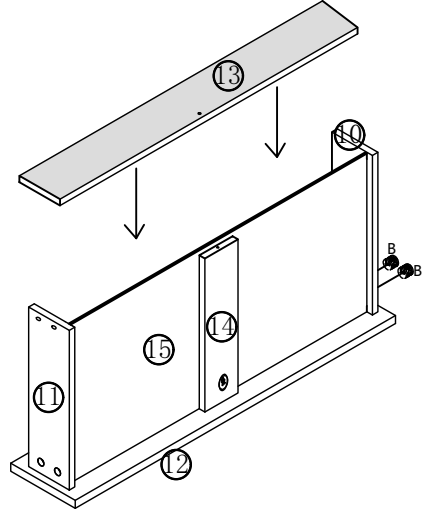
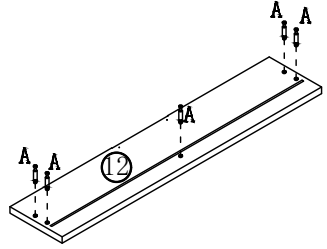
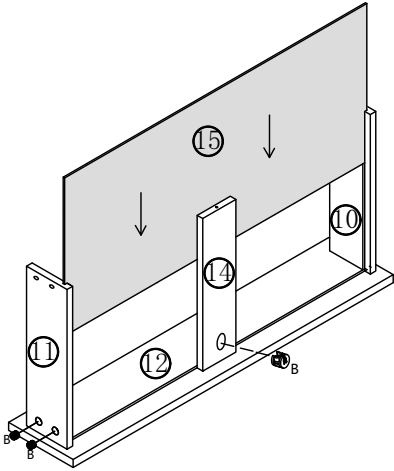

5

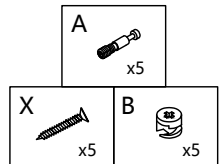

STEP 2

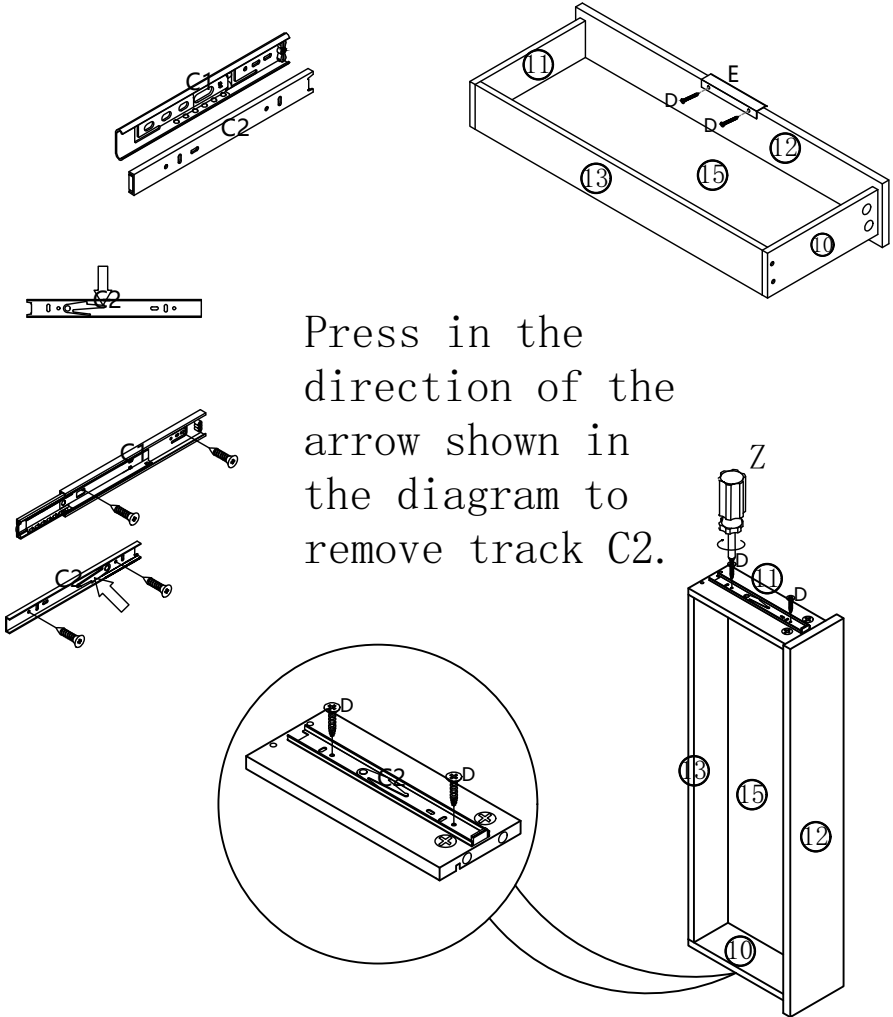



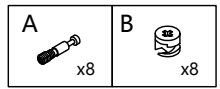
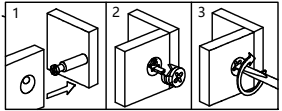
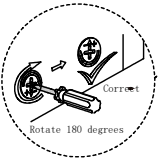
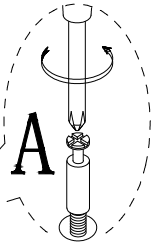
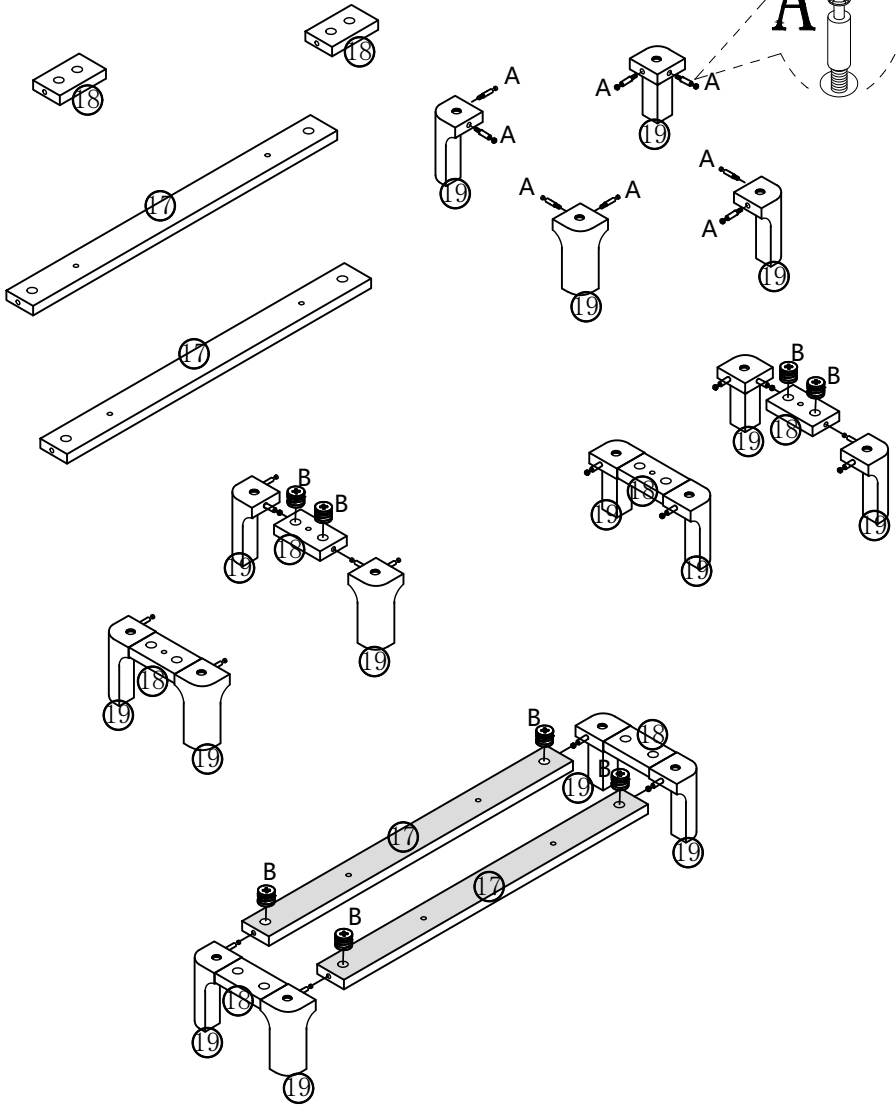

- | | |
|----------|---------|
| E
x1 | |
| C2
x2 | D
x6 |

STEP 3

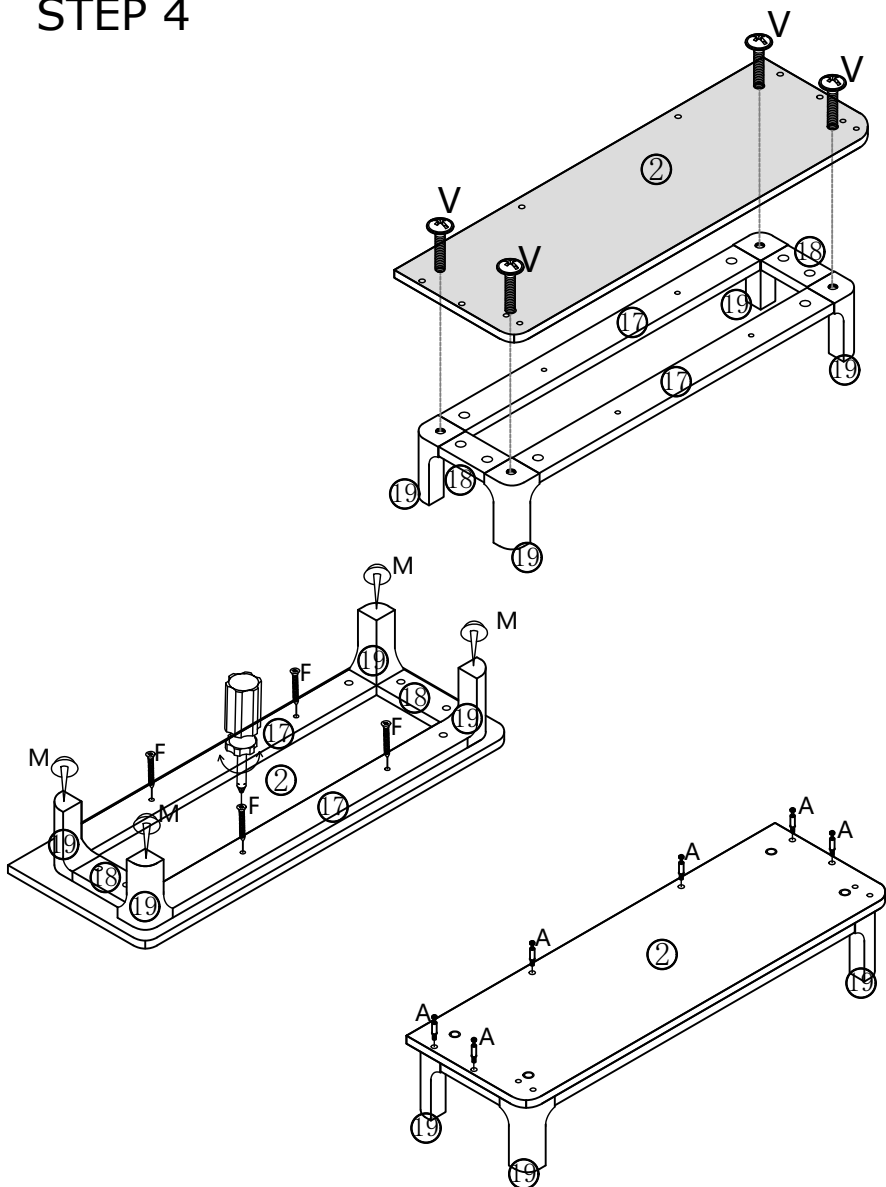

STEP 4



F	A
	
x4	x6
V	M
	
x4	x4

STEP 5

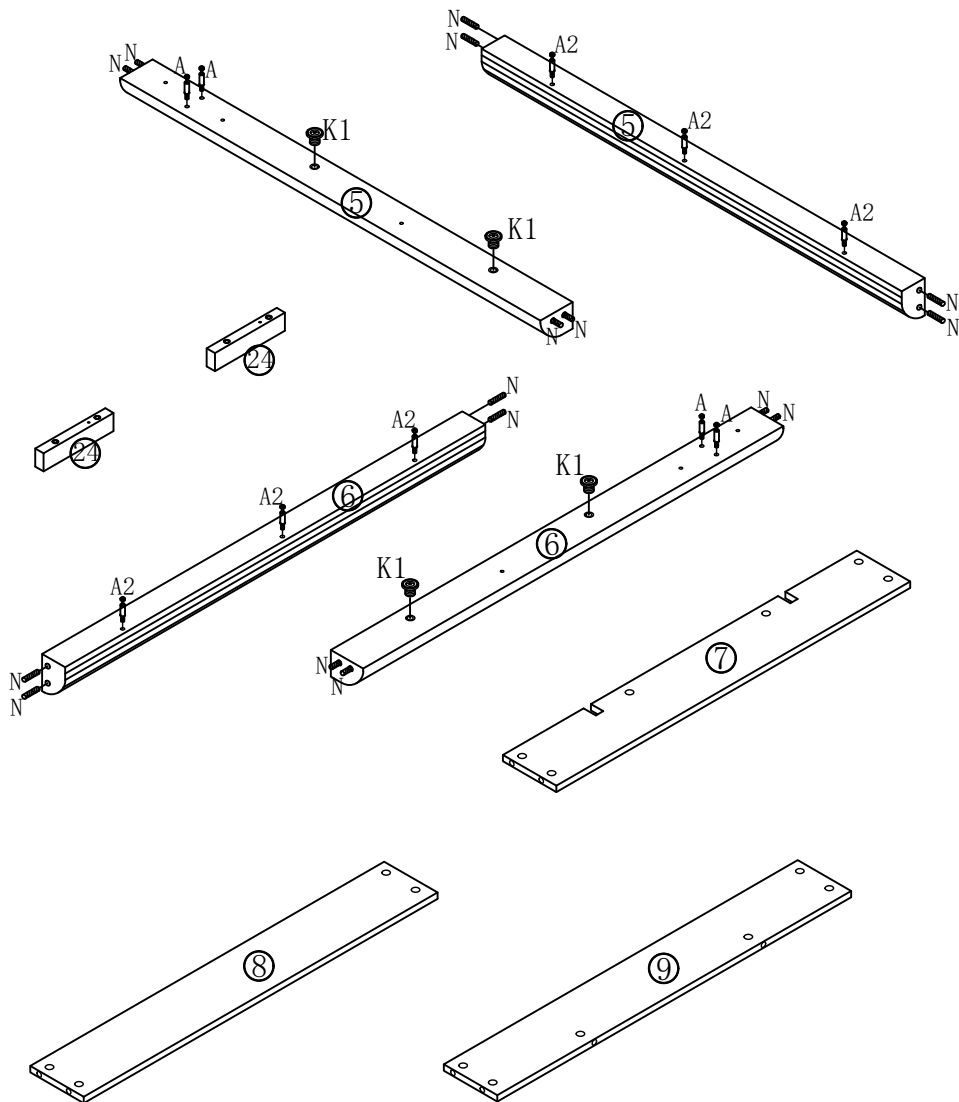

N x8	A x4
A2 x6	K1 x4

STEP 6

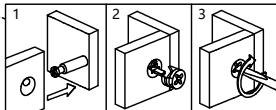
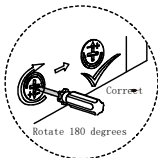
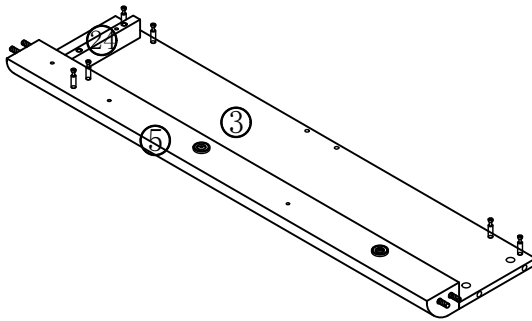
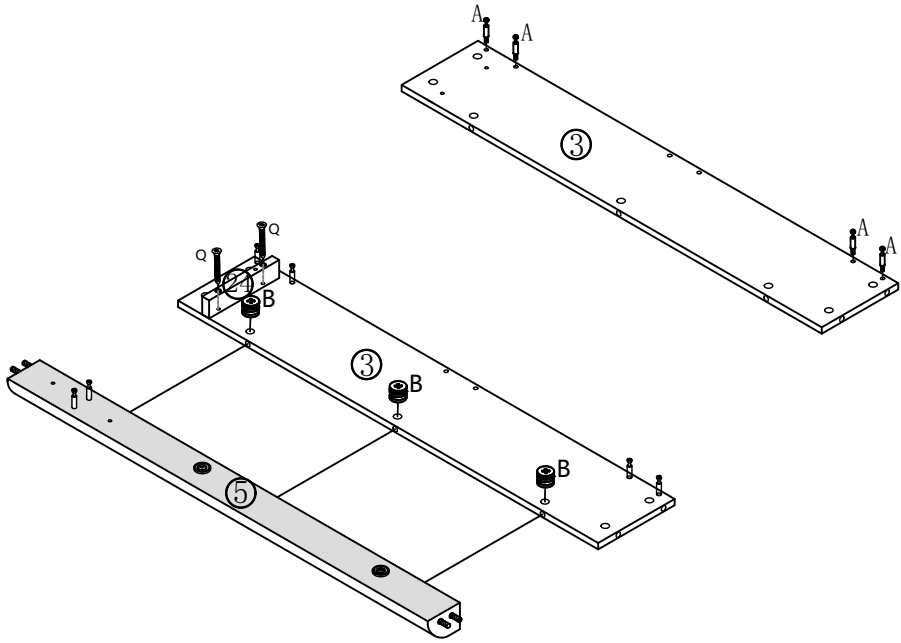

10

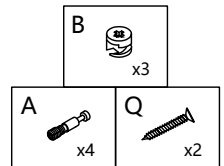

STEP 7

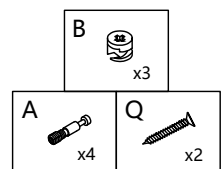
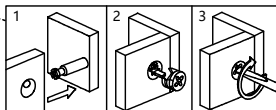
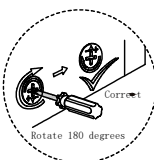
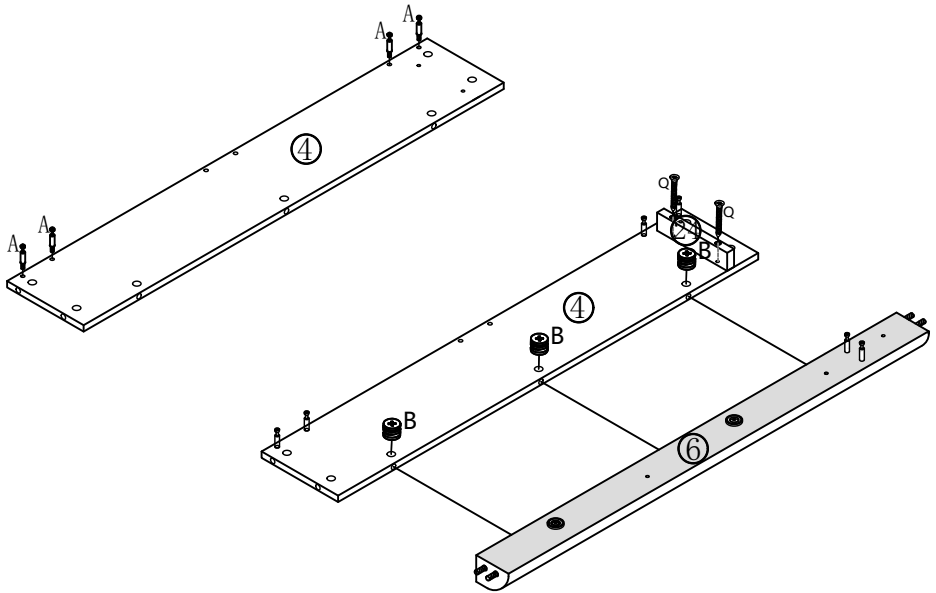

STEP 8

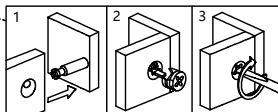
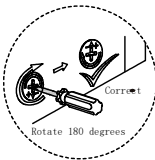
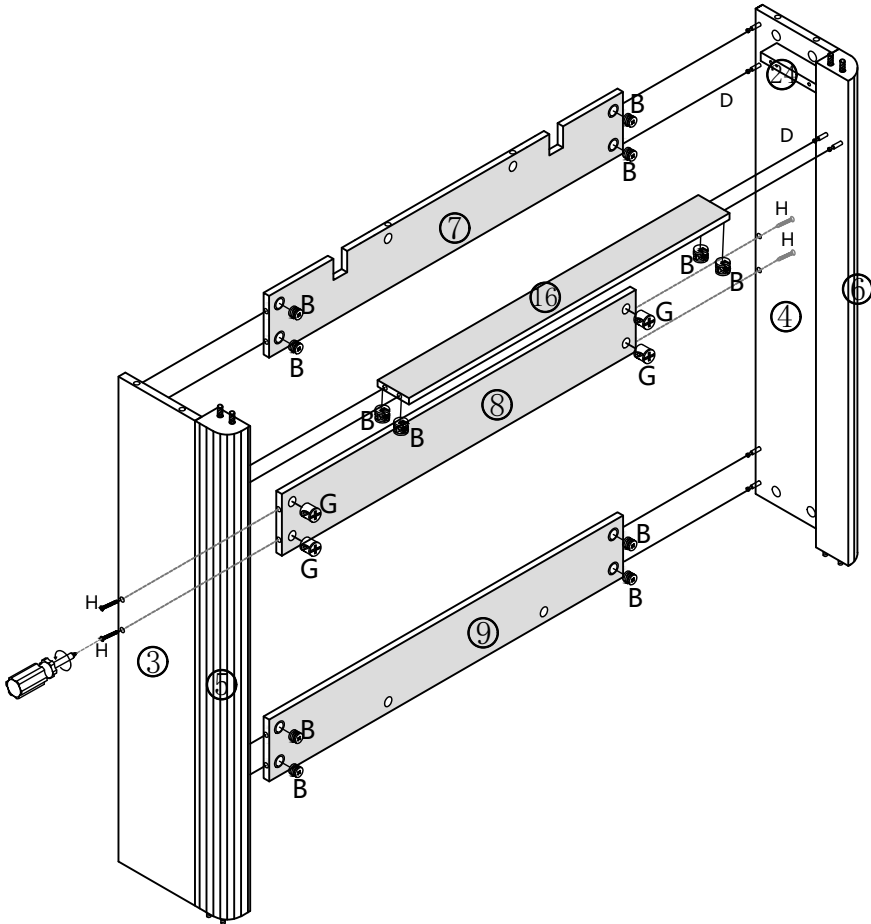

12

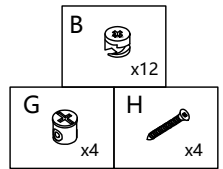

STEP 9

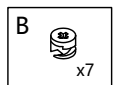
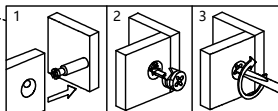
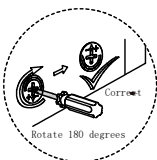
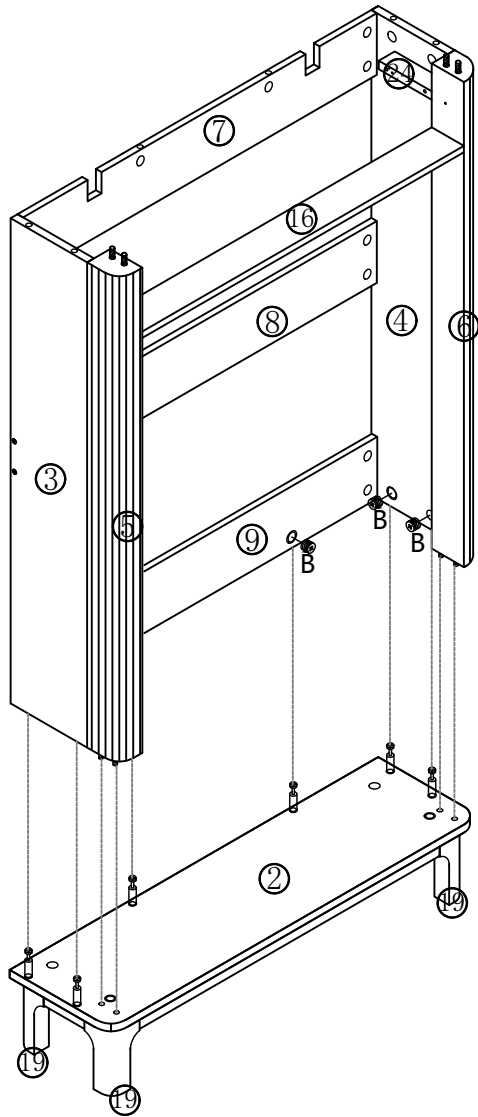



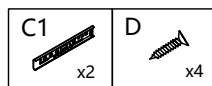
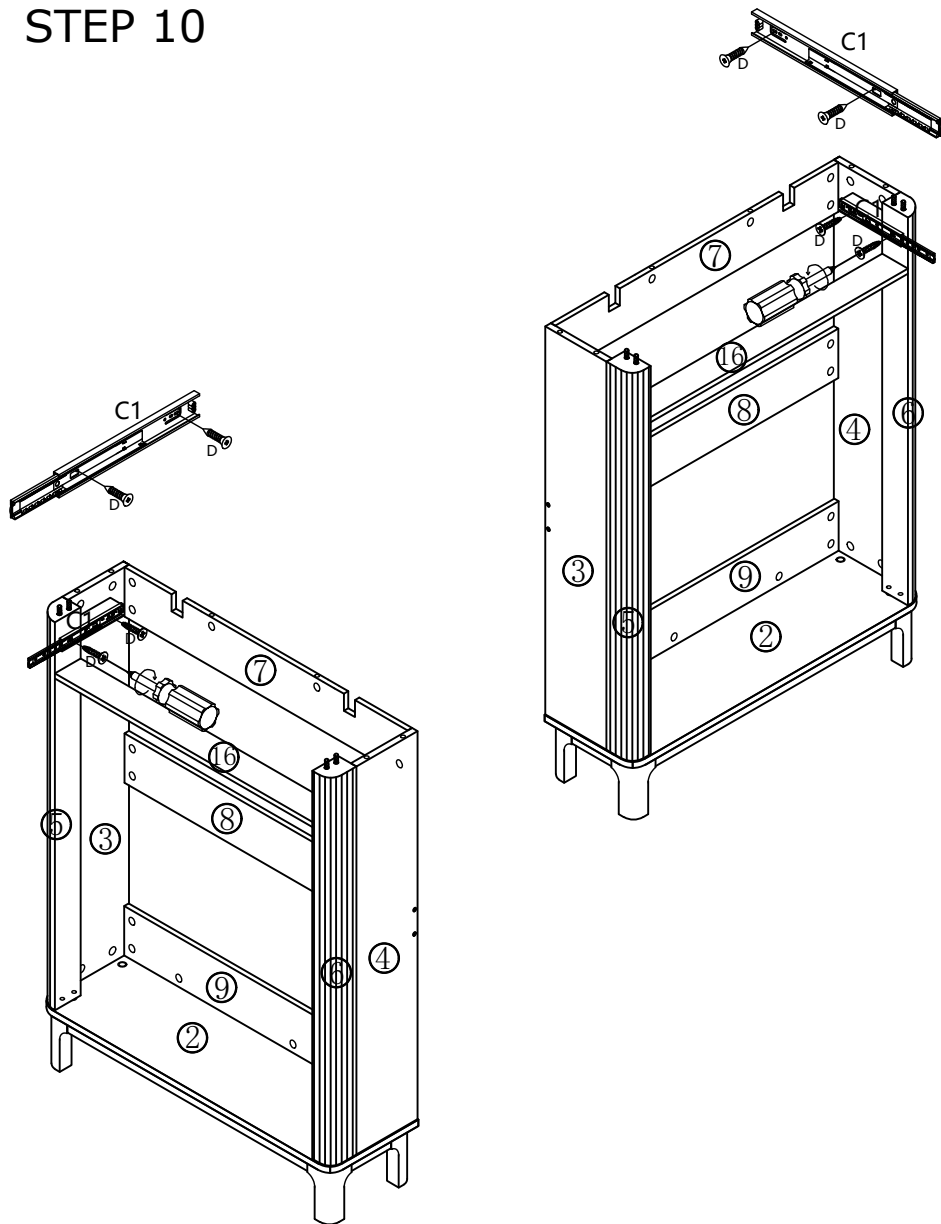

STEP 10

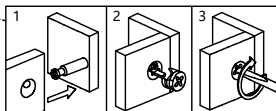
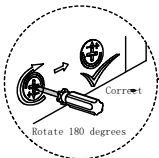
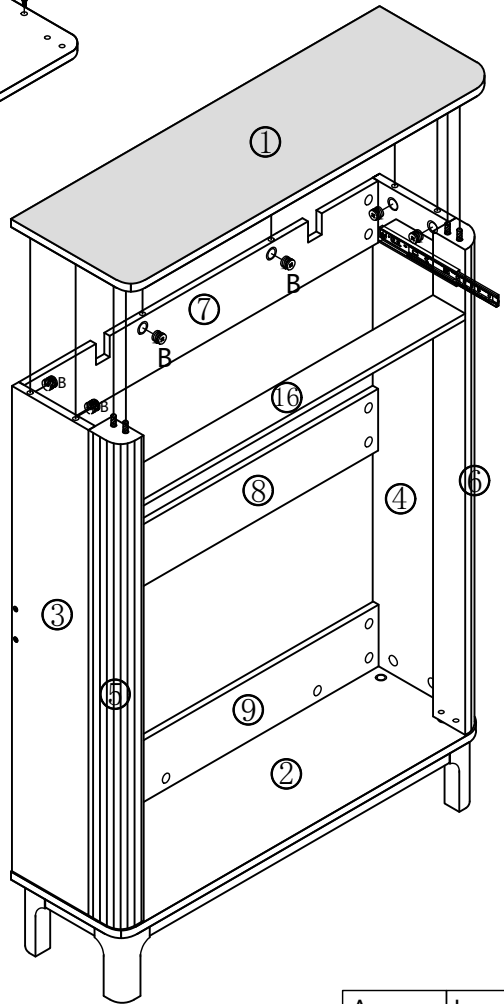
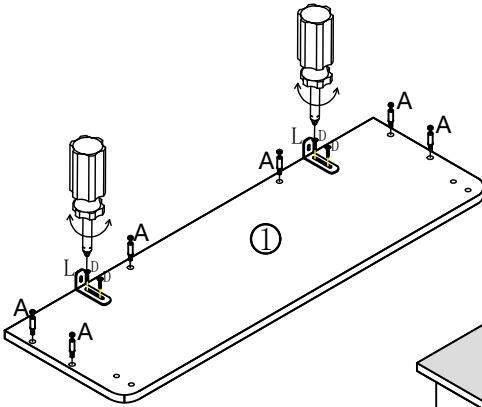

STEP 11



A	L
	
x6	x2
B	D
	
x6	x4

STEP 12

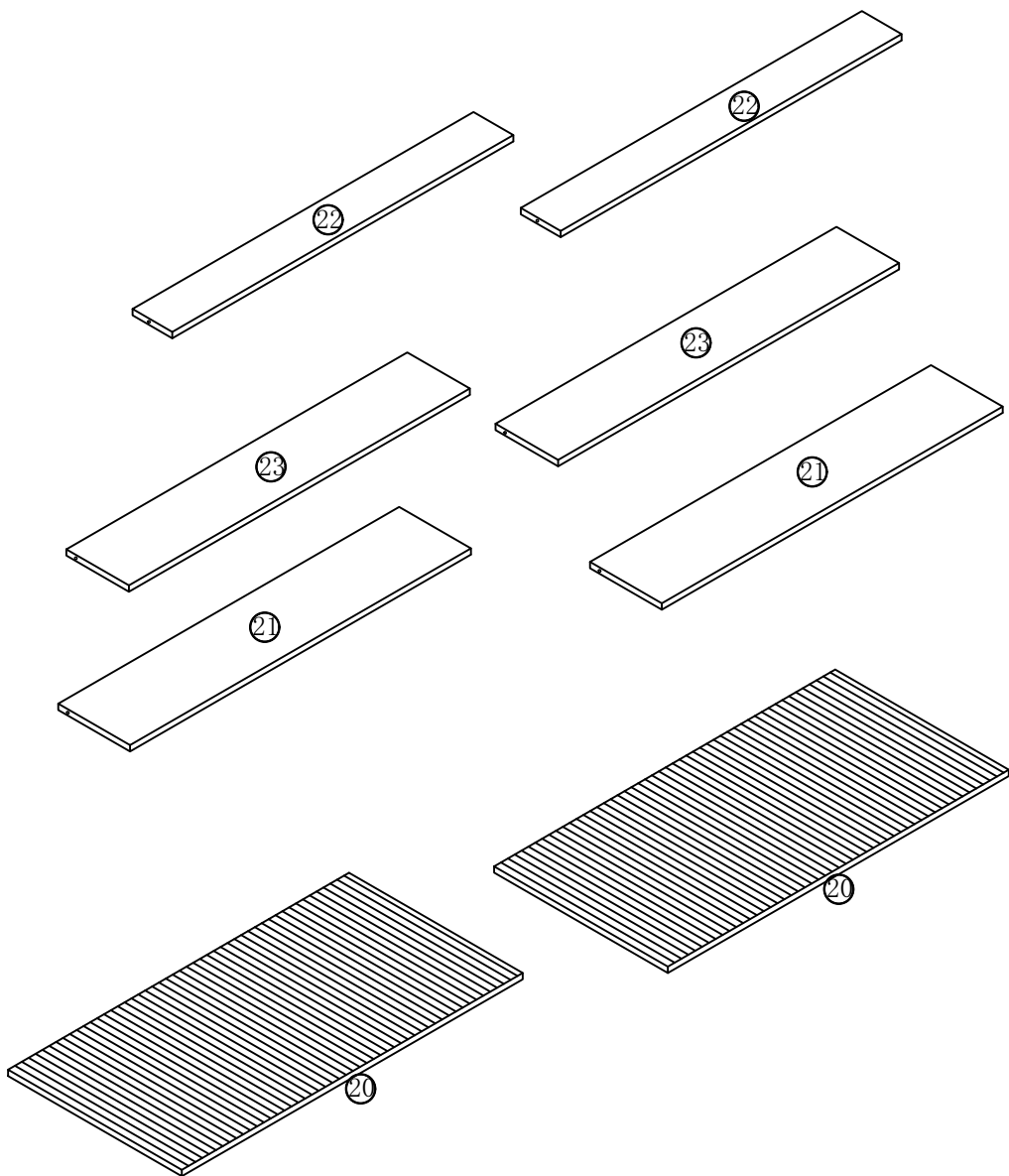

STEP 13

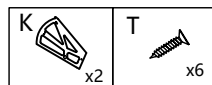
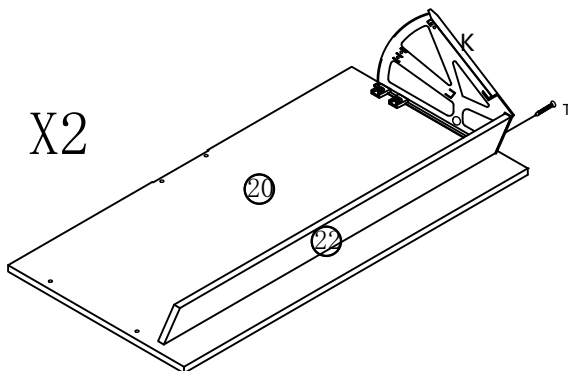
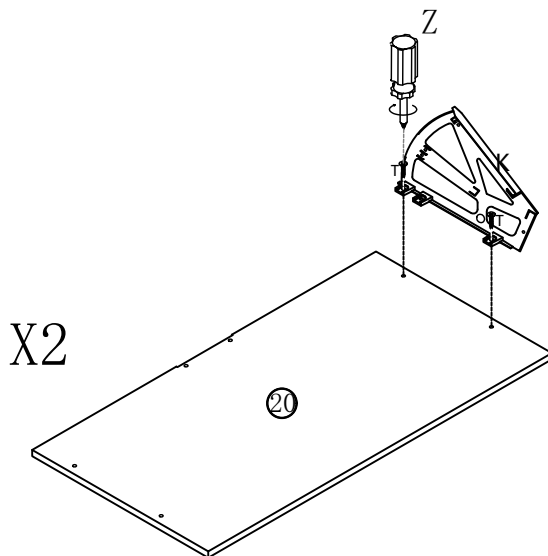

STEP 14

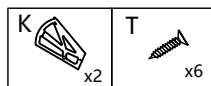
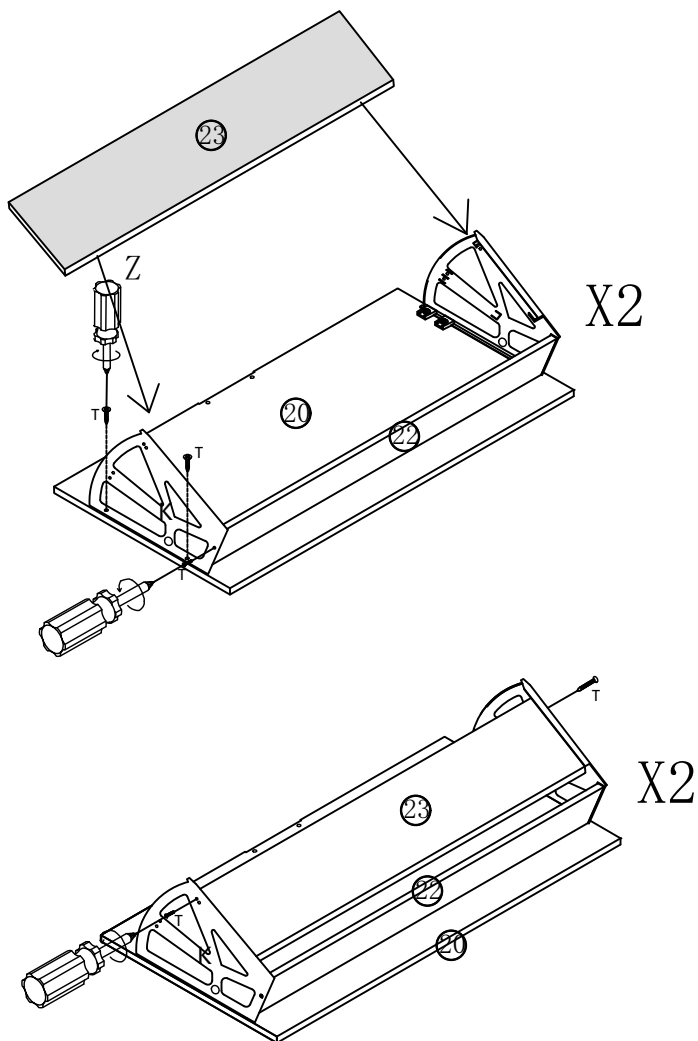

STEP 15

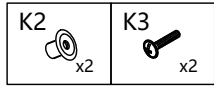
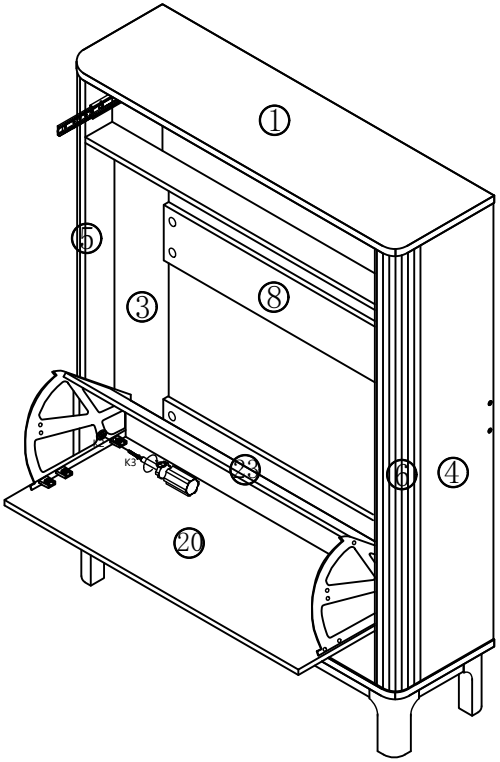
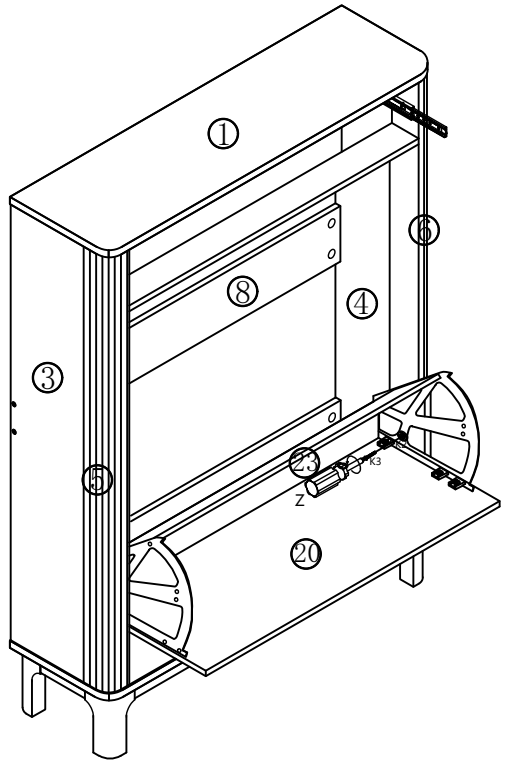

STEP 16

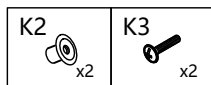
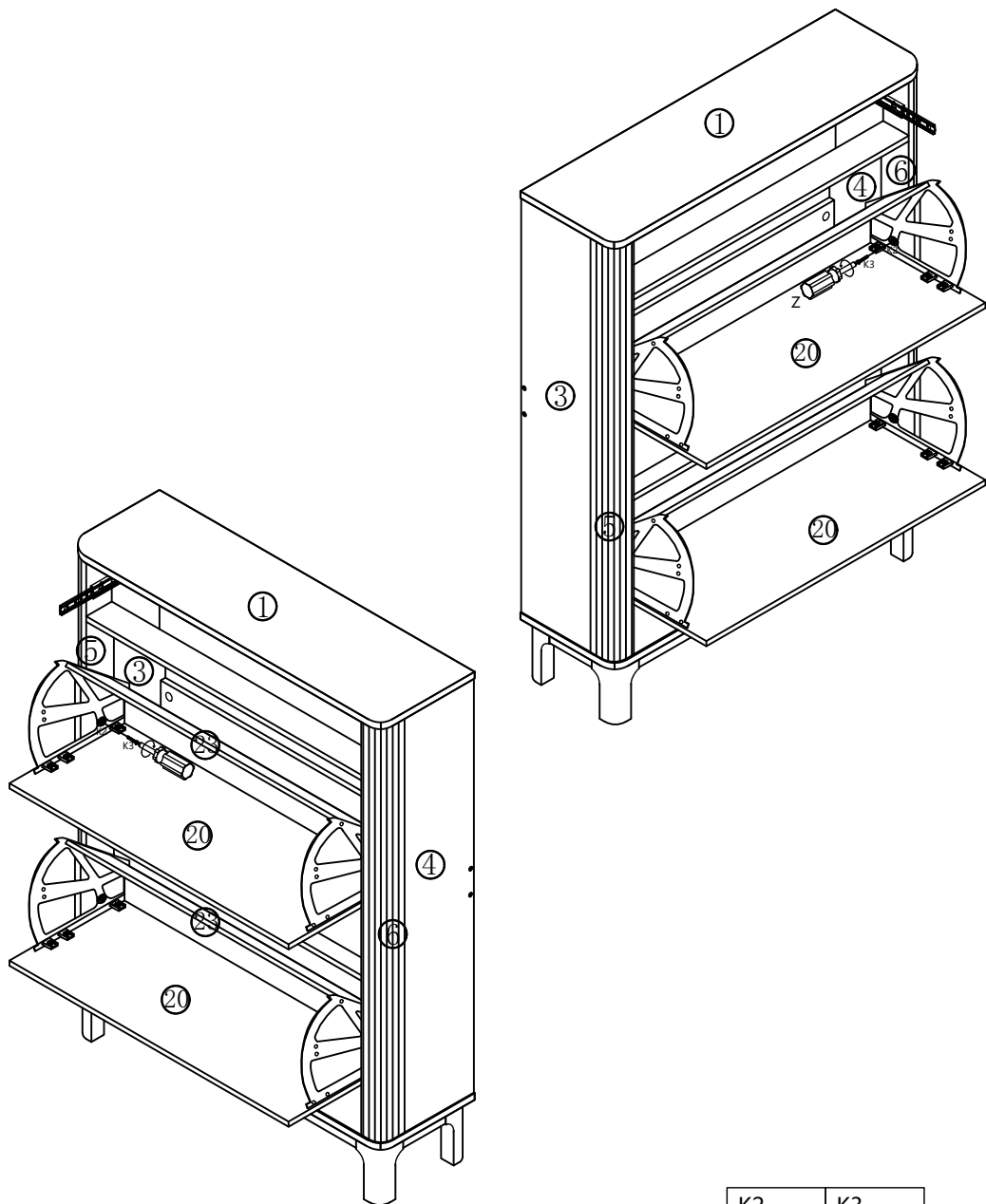

STEP 18

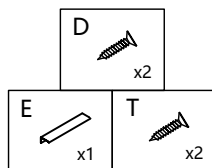
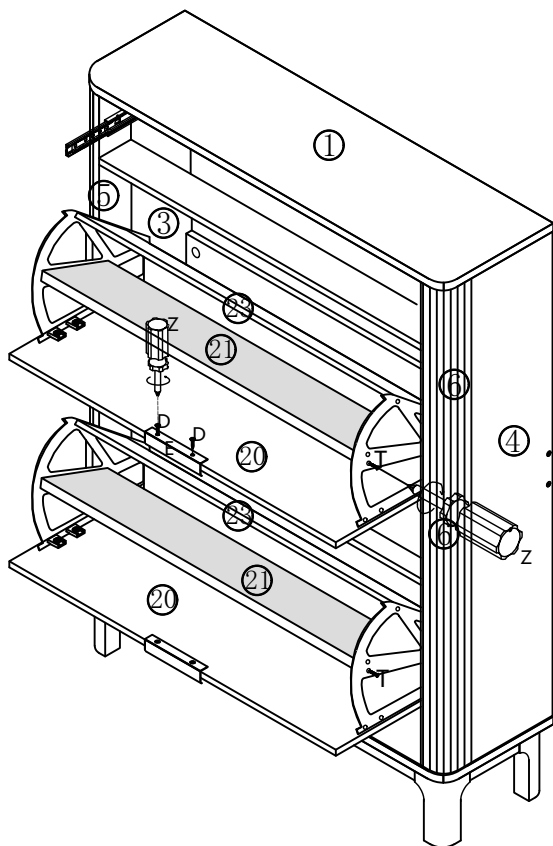

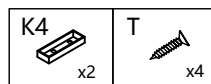
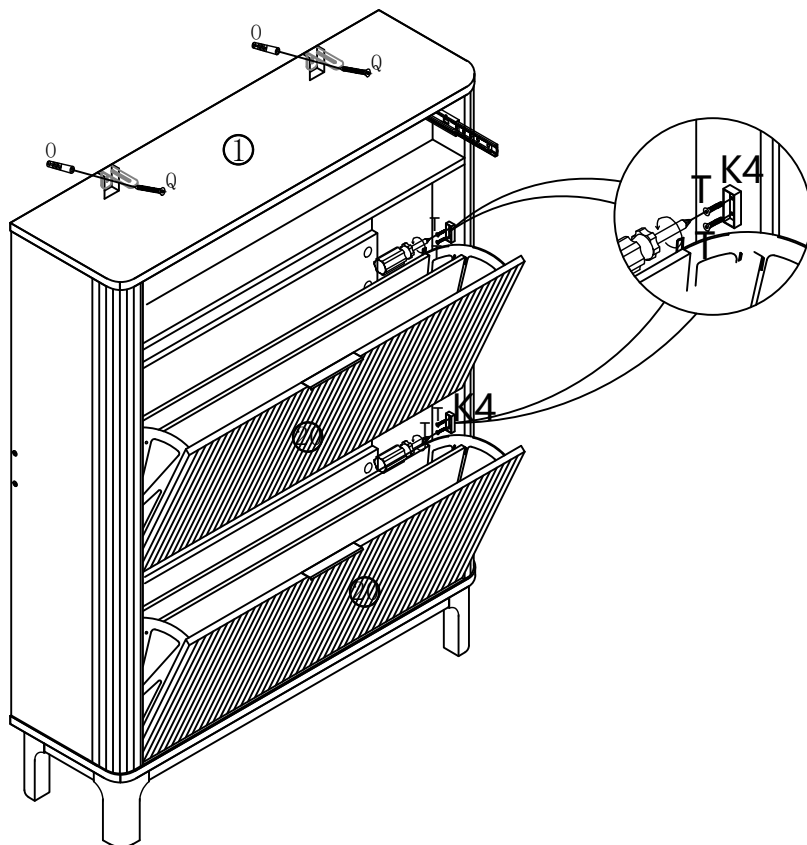

STEP 19

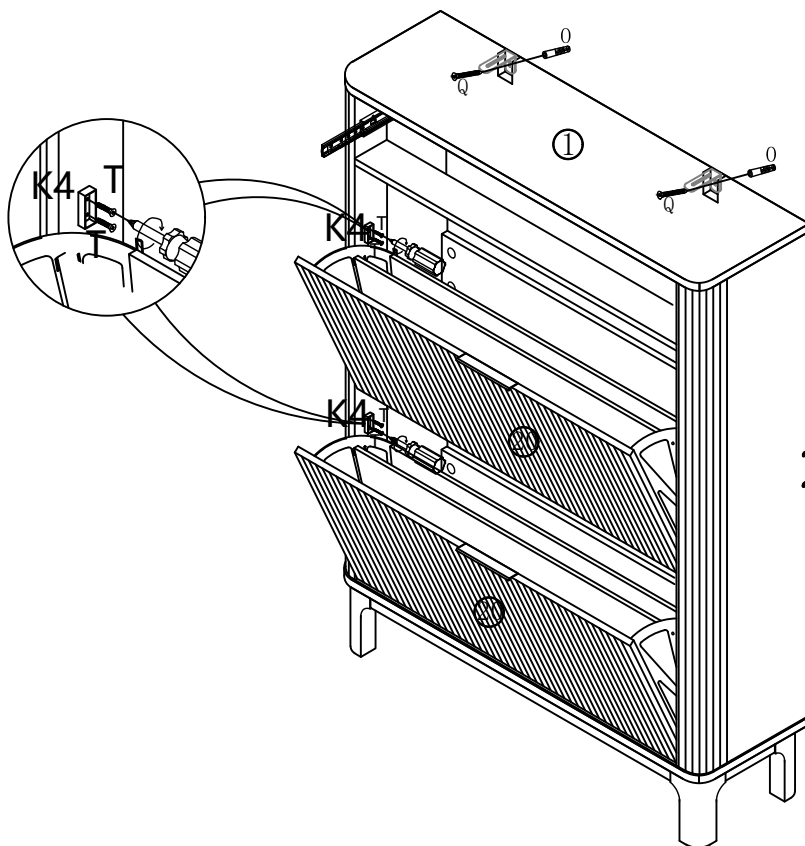

STEP 20



K4  x2	T  x4
---	---

STEP 21

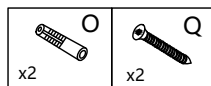
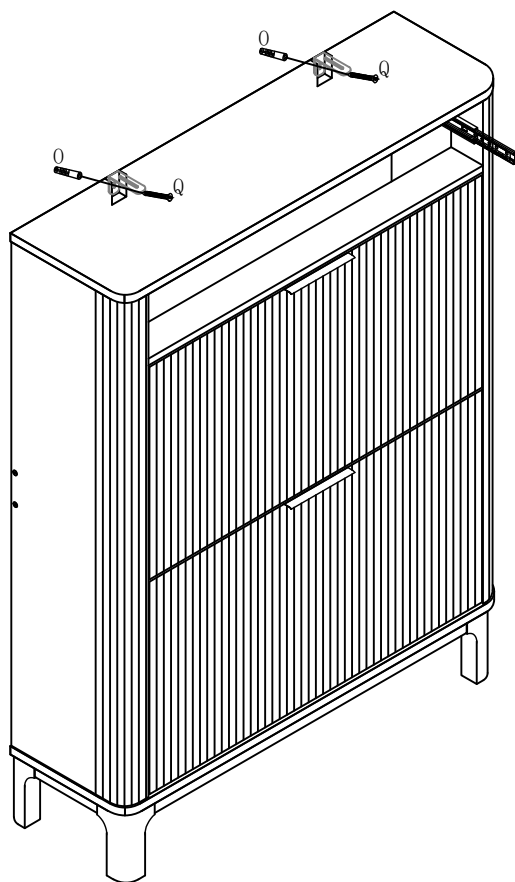

STEP 22

