







CARE AND MAINTENANCE

Wipe clean with a soft, dry cloth. The seat board can be cleaned with a mild cleaner. Test the cleaning method on a hidden area before using them over the entire area.

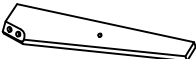
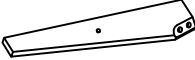
NOTICE

- * Please make sure that you have all parts indicated before you begin assembly of this item.
- * This item should be assembled on a soft surface to prevent scratching the finished product during assembly.
- * This item may require periodic tightening.
- * Do not tighten bolts until completely assembled.

Part List and Hardware List

Piece	Description	Picture	Quantity
A	TABLE TOP		1 X
B	LEFT LEG		2 X
C	RIGHT LEG		2 X
D	METAL SHELF		1 X
E	CONNECTING BAR		2 X
H1	ALLEN BOLT 5/16* 2"		8 X
H2	ALLEN BOLT 1/4* 1"		4 X
H3	SCREW 8mm* 1-5/8"		4 X
H4	ALLEN KEY 4mm		1 X

Product Dimensions: 47"W*23-1/2"D*18"H

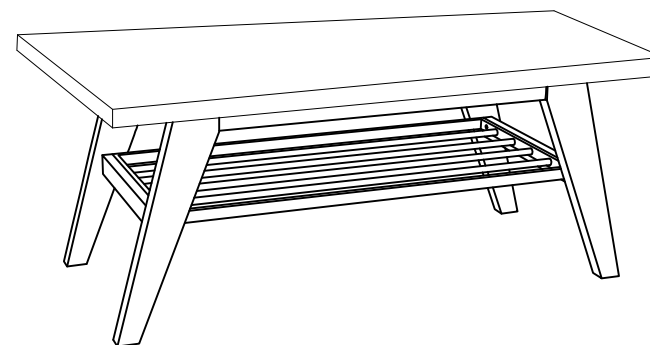

Weight Capacity : 25 lbs

Warning : Do not stand on table

Warning : Do not over torque bolts

PREPARATION

Before beginning assembly of product, make sure all parts are present. Compare parts with package contents list and hardware contents list. If any part is missing or damaged, do not attempt to assemble the product.

Estimated Assembly Time:15 minutes.

Tools Required for Assembly : Allen Key (included) and Philips head screwdriver (not included).

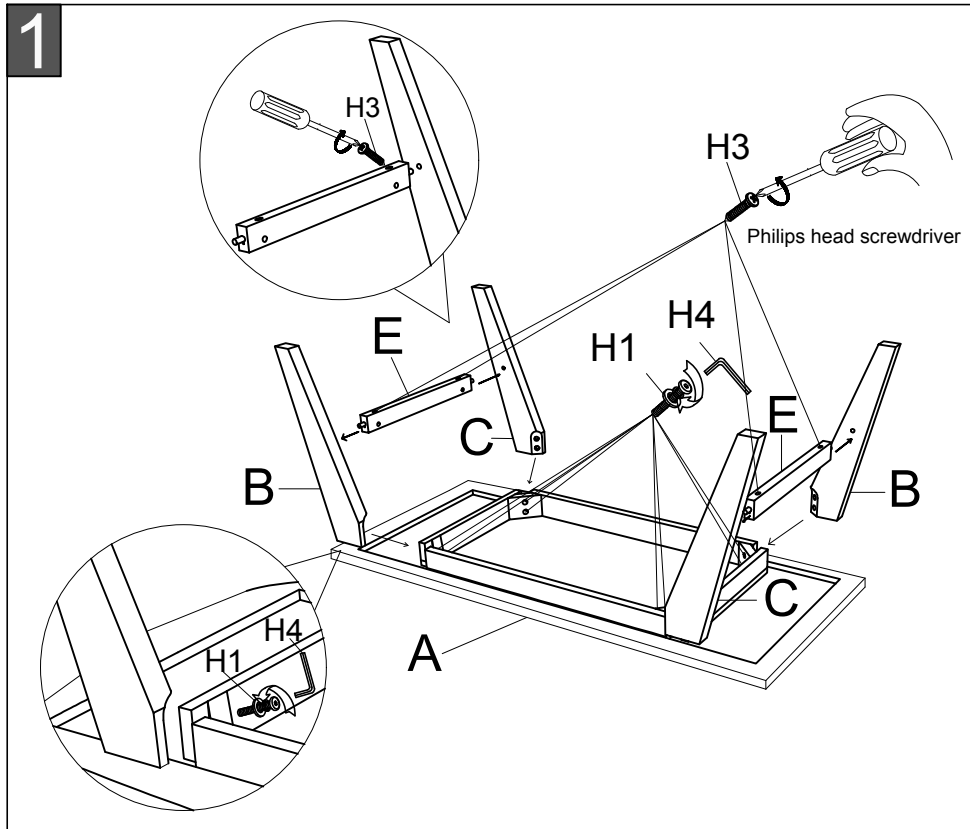

Step 1:

Attach connecting bar (E) to 1*left leg (B) and 1*right leg (C) **The side with a screw hole is facing inward**. Repeat this process to attach the other side leg. Put the assembled legs to the apron on underneath of table top (A) by using Allen key (H4) to lock with 8*Allen bolts (H1), then use the Philips head screwdriver (not included) to lock with 4*screws (H3) into connecting bar, as picture.

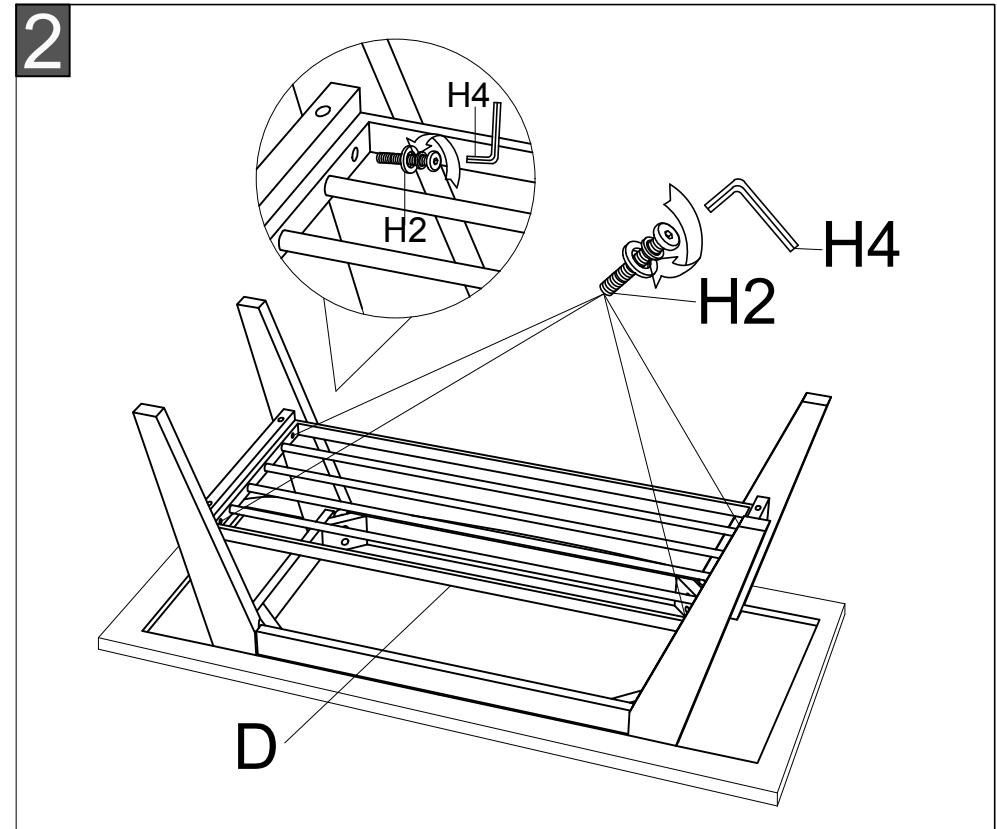

Step 2:

Attach the metal shelf (D) to the assembled connecting bars by using the Allen key (H4) to lock with 4*Allen bolts (H2), as picture. Straighten up the assembled product, Assembly is completed.