

ASSEMBLY INSTRUCTIONS

loveseat

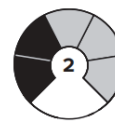
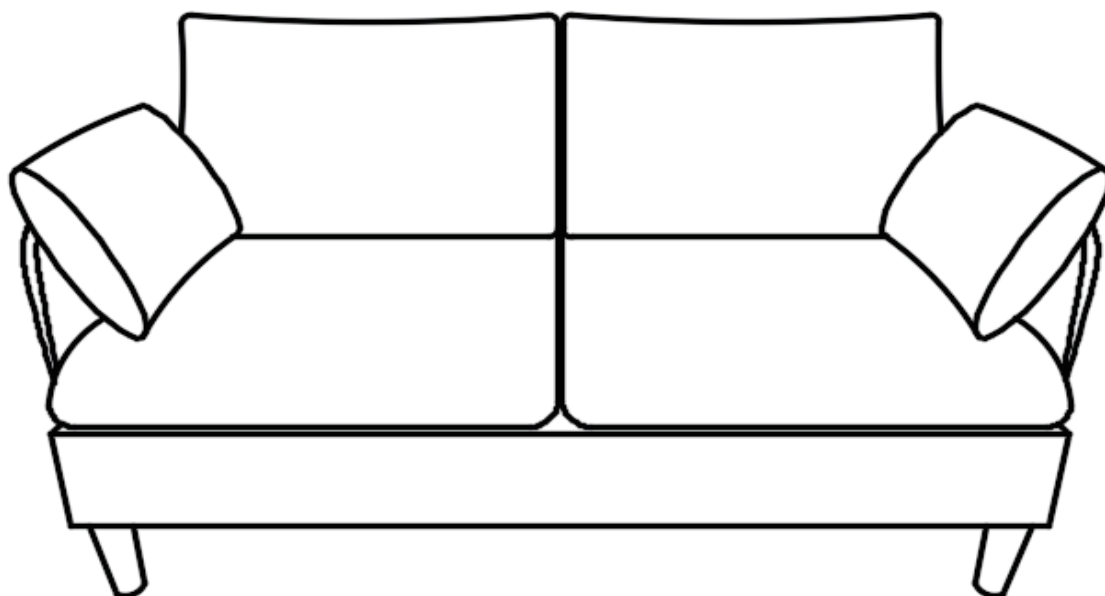

NOTICE

Instruction Booklet - Important Safety Information

Thank you for choosing our product. Please review this booklet carefully for essential safety information and keep it for future reference.

- Upon receiving the product, **ensure all parts are present and intact** before proceeding with installation. Follow the entire installation instructions provided.
- During installation, exercise caution and refrain from immediately tightening screws. Secure all screws to 80% before final tightening.
- Note: Cushions are **compressed** and cannot be recompressed once opened.

Safety And Care Advice (EN)

Important-Please read these instructions fully before starting assembly.

1. Please check if all the components and tools listed out are received.
2. Please remove all fittings from the plastic bags and separate them into homologous groups.
3. Please keep children and animals away from the working areas; swallow small parts may cause suffocation.
4. Please make sure you have enough space to lay out the parts before starting.
5. Do not stand on the product, which could cause damage.
6. Please assemble the product as close to its final position as possible.
7. Do not place furniture directly in front of radiators, fires, or any other source of heat.
8. The assembly will be easier with 2 people.
9. Please dispose of a packaging carefully and responsibly.



Before installation, please check that the parts are all included !

NOTICE

General care and maintenance

1. Please clean with a damp cloth or mild detergent, do not use bleach or abrasive cleaners.
2. Do not allow the spill to stay on the surface for a long time.
3. Do not clean with products containing the following: acetone (e.g., nail varnish remover), ammonia (e.g., bleach), or sodium hydroxide (e.g., caustic soda, drain, and oven cleaners).
4. If the product is accidentally exposed to the irritating liquid, rinse thoroughly with clean water.
5. Mats can be used to protect surfaces from moisture and heat.
6. Please check whether there are missing screws in the product regularly.
7. The product should not be discarded with household waste, and please take it to your local authority waste disposal center.



Before installation, please check that the parts are all included !

BOX 1/2

Materials ▾

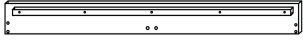

A*1

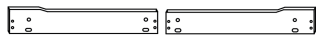

B*2



C*1

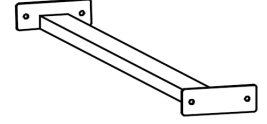

D*1

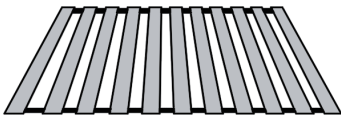

E*1

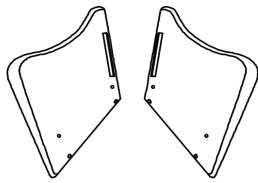

F*2



G*1



H*8

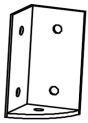

I*4

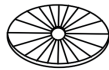

J*4

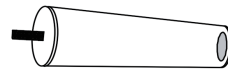

K*4

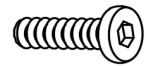

L*20



M*8

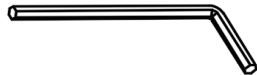

N*1

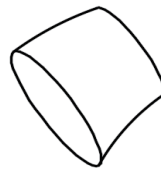

O*2

BOX 2/2

Materials ▾

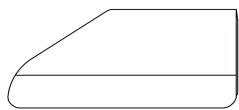

P*2

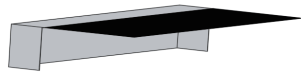

Q*1



R*1

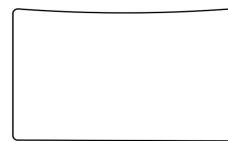

S*2

Installation Steps

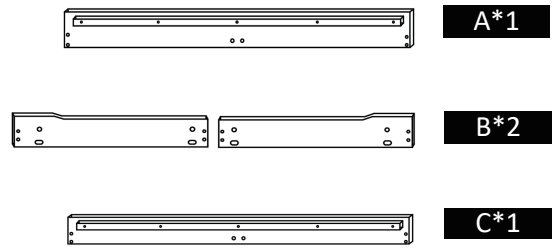
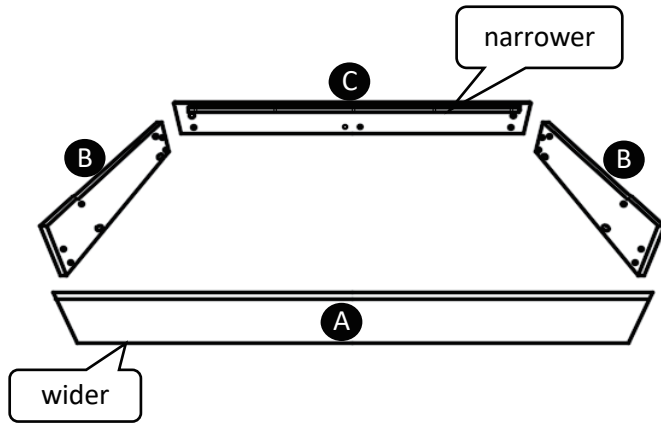

Place each frame partition board in position as shown in the diagram.

STEP 1

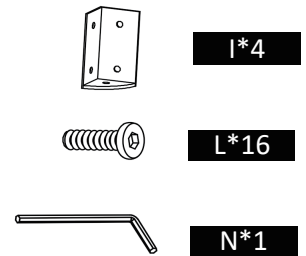
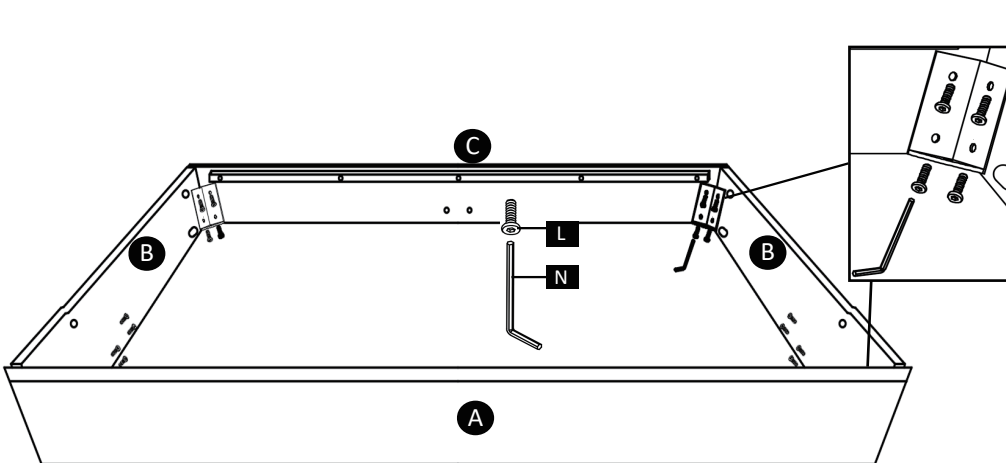

As shown in the diagram, connect each frame baffle plate with the connector and tighten with bolts.

STEP 2

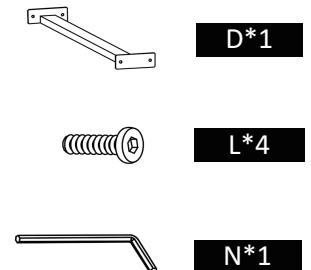
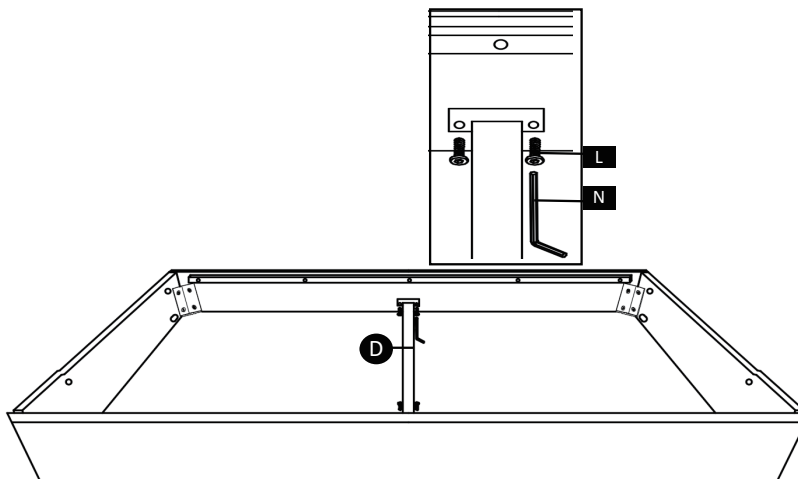

STEP 3

Tighten the middle support pole with bolts as shown in the diagram.

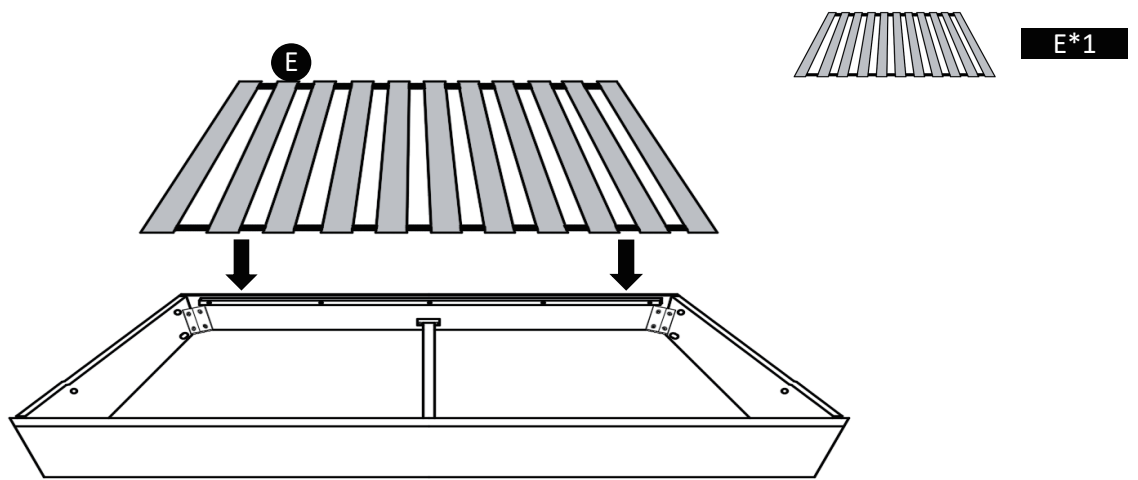

STEP 4

Place the seat plate flat on the assembled seat frame.

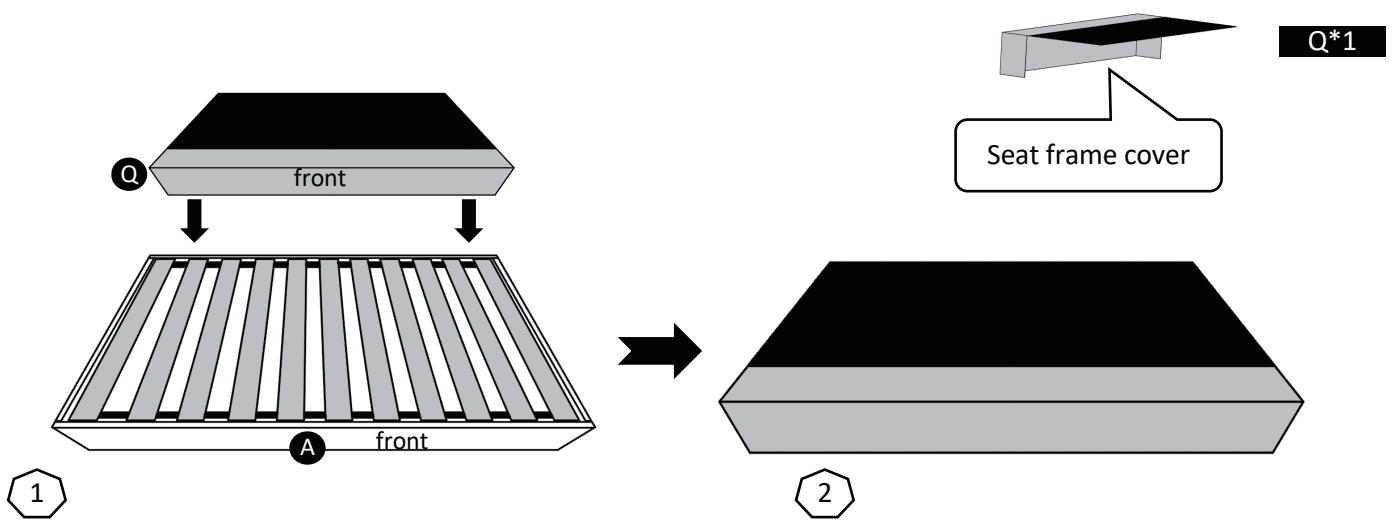

STEP 5

Smoothly drape the seat frame cover over the sofa seat frame.

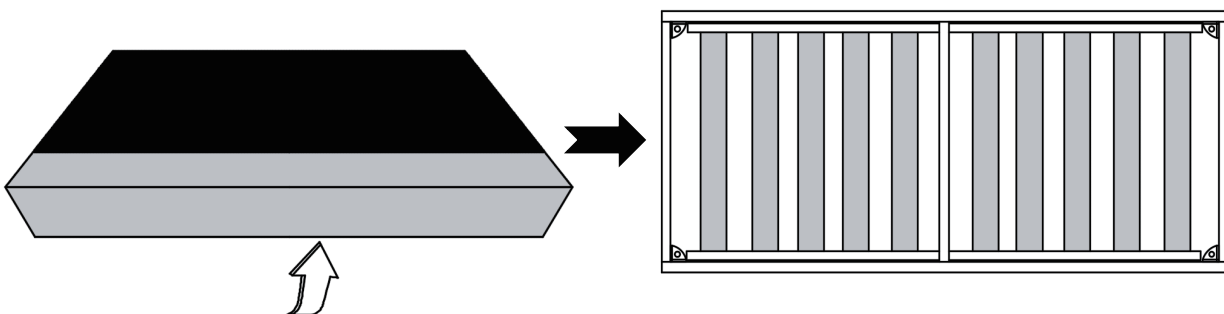

Lift the sofa seat frame as shown in the picture.

STEP 6

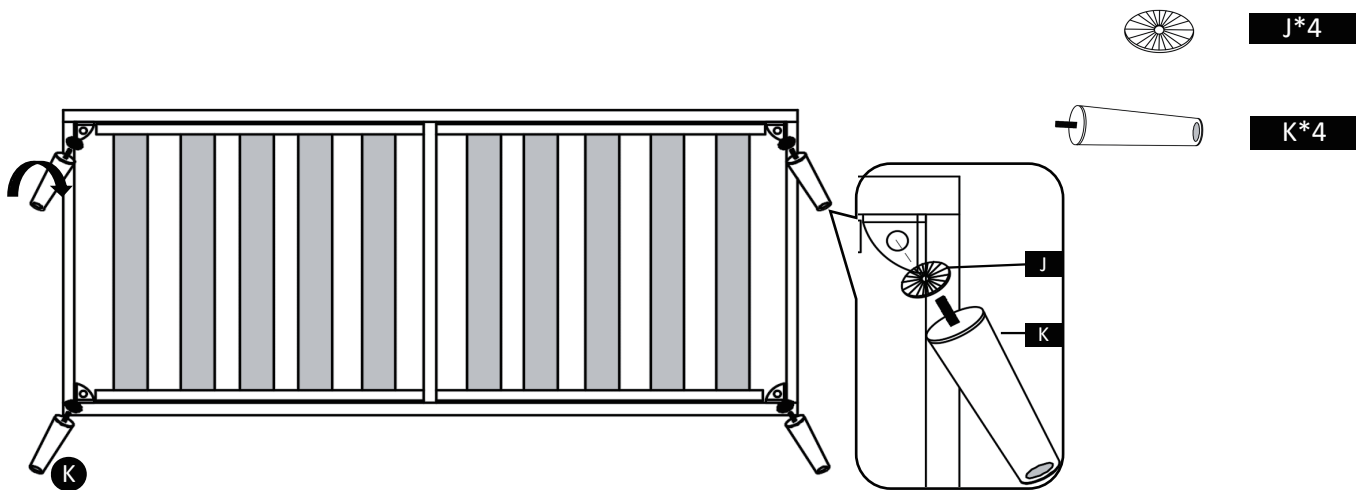

Screw the four wooden feet into the holes respectively.

STEP 7

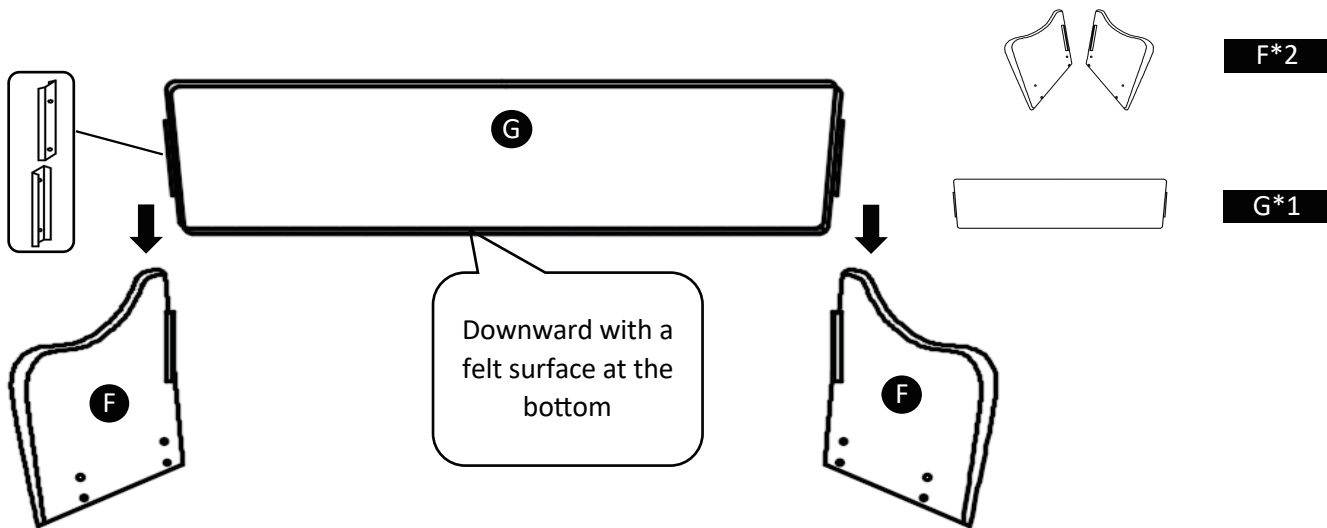

Insert the backrest and armrest inserts tightly into each other.

STEP 8

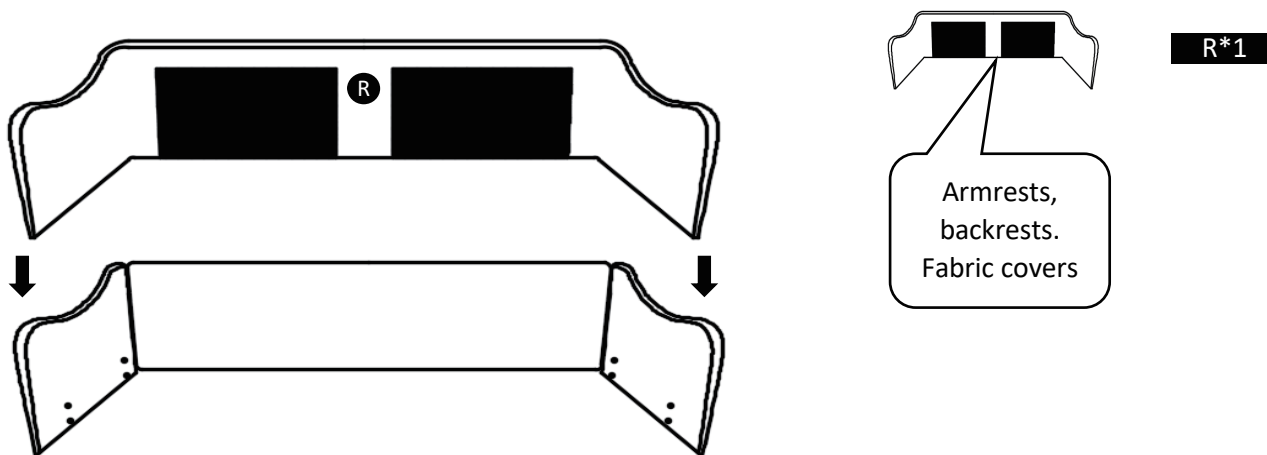

Cover the sofa with the slipcover. Make sure it's on properly.

STEP 9

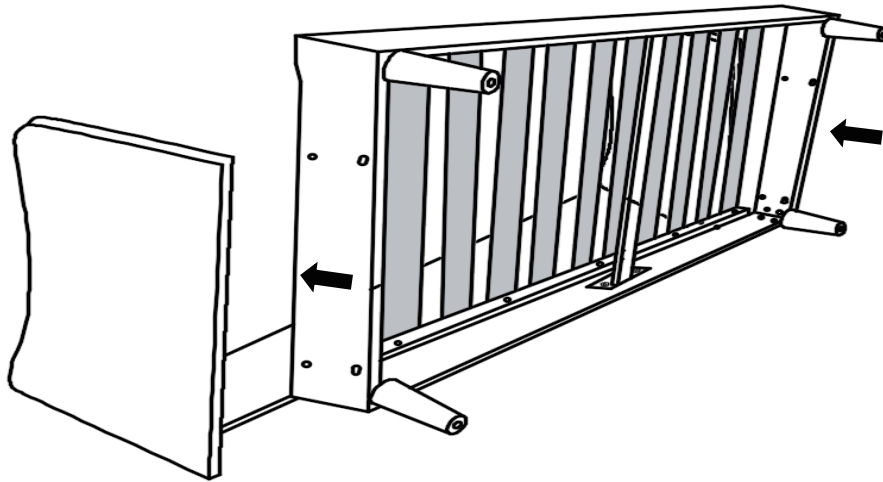

Put the sand seat frame into the connected frame.

STEP 10

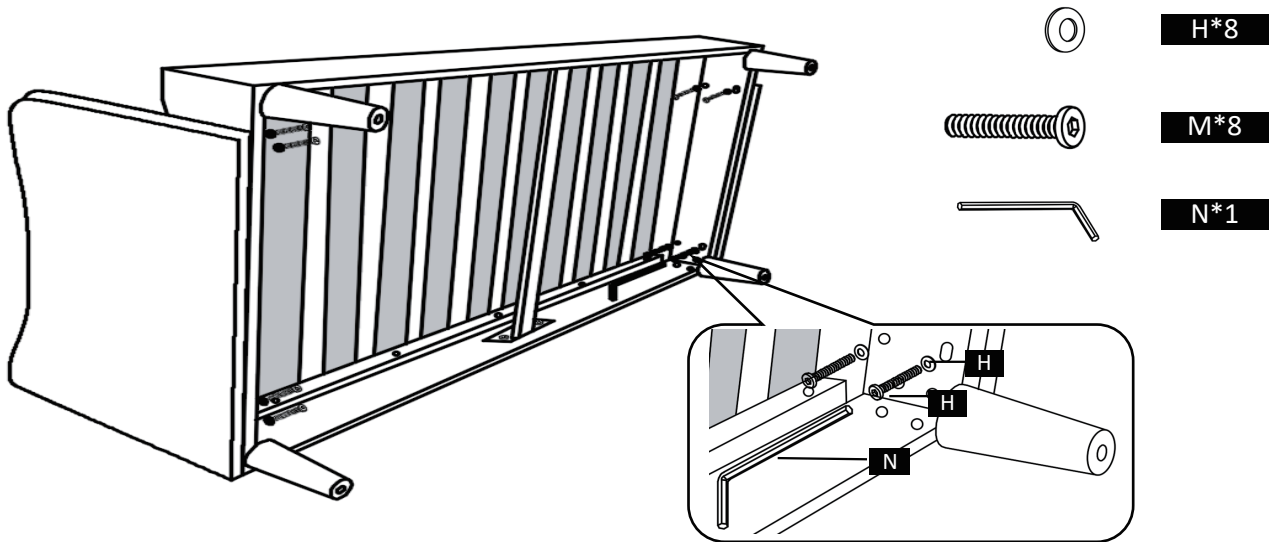

STEP 11

Tighten the left and right armrest plates to the seat frame respectively with 8 bolts.

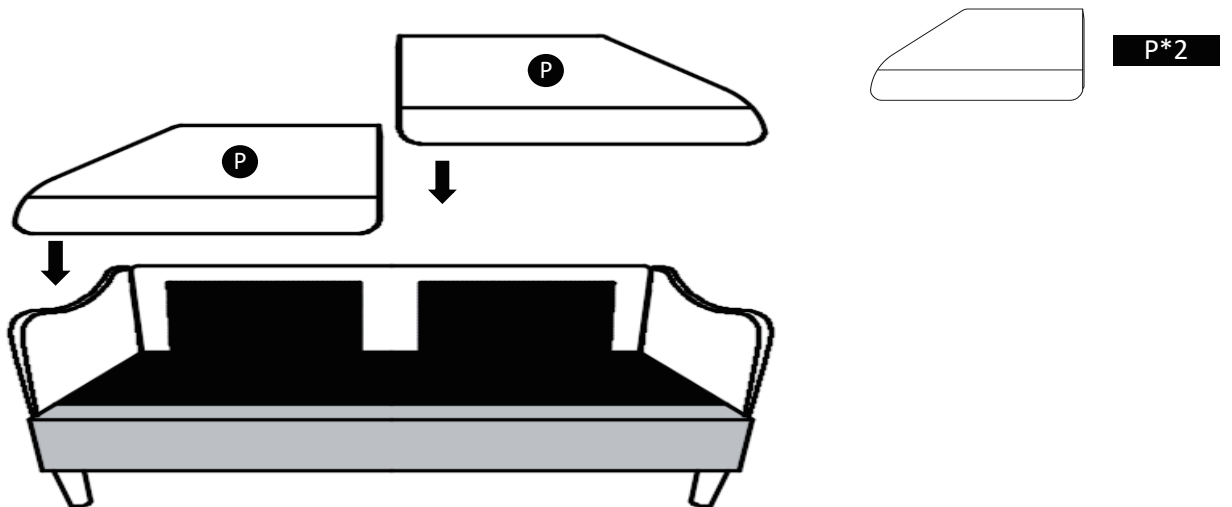

STEP 12

Lay the sofa seat cushion flat and in place.



S*2

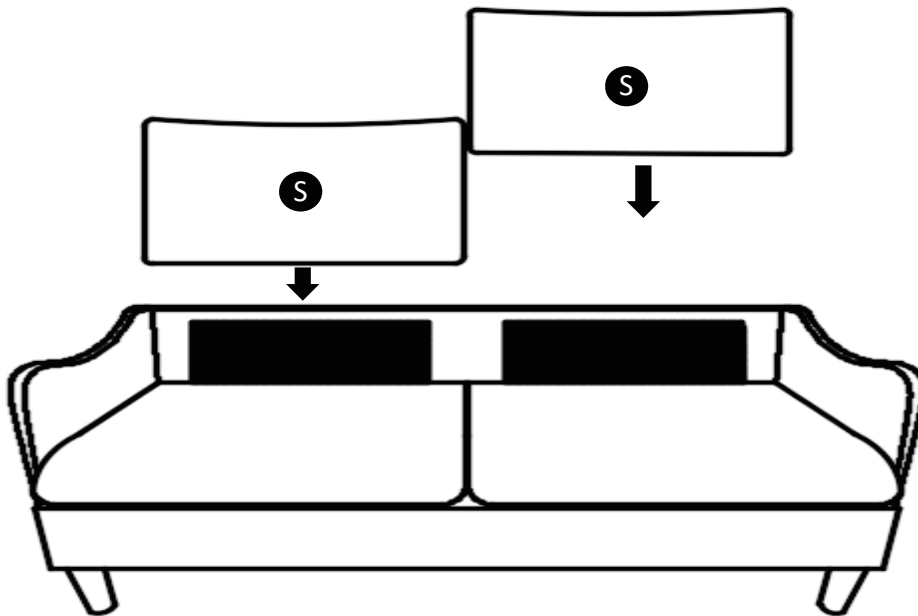

Flatten and place the sofa cushions neatly.

STEP 13

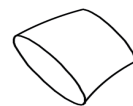

O*2

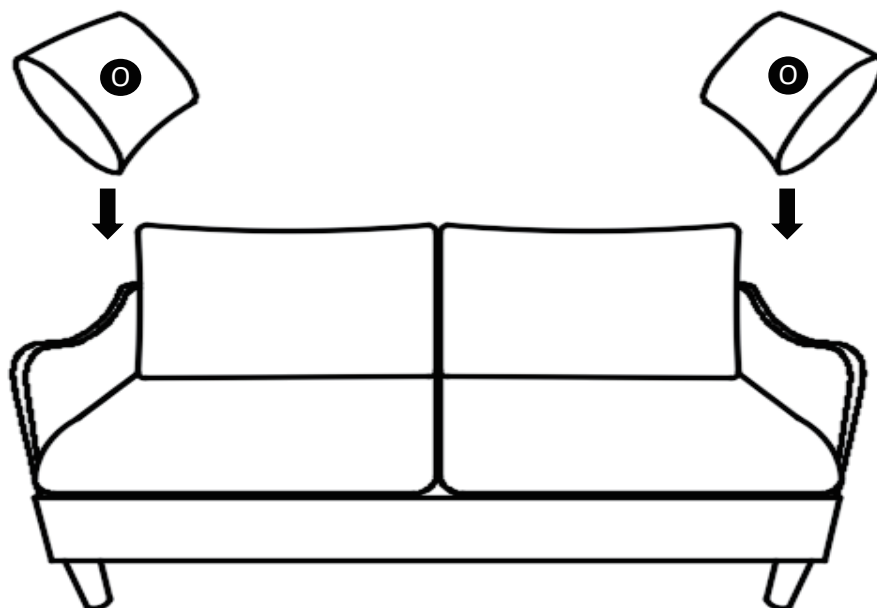

Lay the sofa armrest covers flat and neatly.

STEP 14

Frequently Asked Questions

We understand that receiving damaged or defective products can be disappointing, and we're here to assist you every step of the way. Here's how to address common concerns and initiate a damage claim:

1.What should I do if my shipment is damaged or products received are defective?

We're genuinely sorry to hear about any inconvenience caused. Please reach out to us promptly, and our team will prioritize resolving the matter swiftly and effectively. To file a damage claim, follow these steps:

A. Retain the original box in case a return is required.

B. Take photos of the damaged box, the damaged part of the item, tracking number, and return label on the box to help us process a replacement or refund.

2.Can I return the product if I'm not satisfied?

While we uphold stringent quality standards and collaborate with experienced manufacturers, we acknowledge that dissatisfaction may arise. If you're still unsatisfied, you can initiate a return within 30 days of receiving the product. Simply message us with your reasons for return, and we'll facilitate the process.