

Outdoor Storage Shed8X6ft Manual

Dear customer,

Thank you for your support.If you have any questions or concerns,please don't hesitate to contact us. Our customer service team is always here to help and assist you in any way we can. Thank you again for choosing our chicken coop.

Street: 8 The Green Suite A

City: Dover State: DE

Post code:19901

Phone:3022415039/

6605538327

Email: easyhelpservice@yahoo.com

Scan the code on your phone and
contact us via email.



sannwsg.com

After-sales phone service hours:

US CentralTime: 19:00-23:00

Seattle time: 17:00-21:00













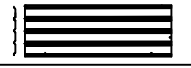





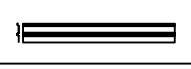
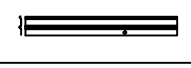
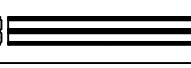

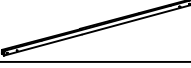

US EasternTime: 20:00-00:00

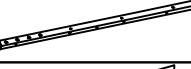
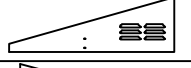
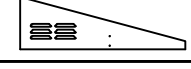

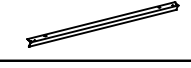



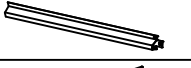



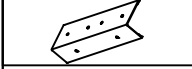
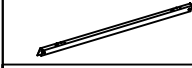
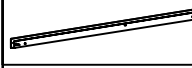

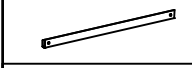
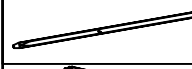

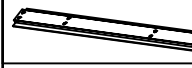



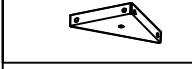

Toronto time: 20:00-00:00

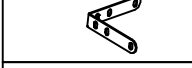
Germany time: 8:00-11:00

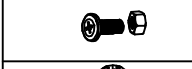
After-sales mailbox service time:
7*24 hours

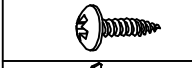
F0806parts list

PART	NO.	QTY.
	W5	9
	W5-K	2
	K57-7L	2
	K57-7M	4
	K57-7R	2
	W5-F	1
	W3-F	1
	W5-C	4
	W2-HL	1
	W2-HR	1
	W3	1
	K812-1	2
	K812-1R	2
	K58-2	2
	K58-3	2
	K57-4L	2
	K57-4	2
	K57-5L	2
	K57-5R	2
	K58-6	4
	K812-8	4
	K57-9L	2
	K57-9R	2
	K57-10L	1
	K57-10R	1
	UA	2
	C3	4

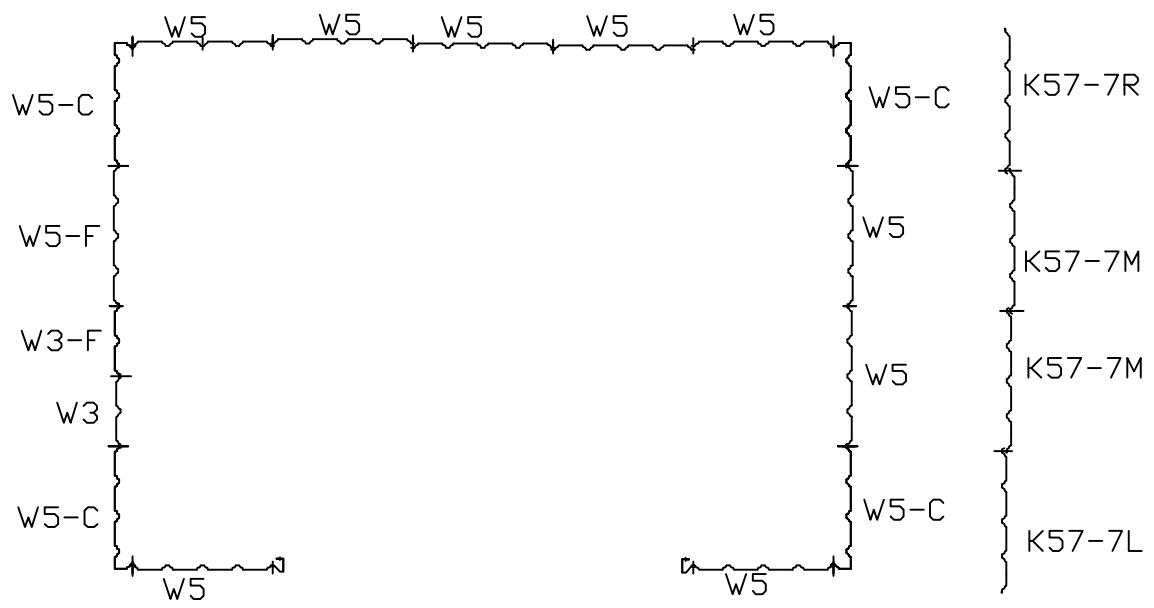

PART	NO.	QTY.
	C4	4
	DA	2
	DLA	1
	DRA	1
	DDA	4
	DBA	4
	TCH	2
	TCH3	1
	TCH5	1
	TCH6	1
	TCH7	1
	GC	4
	GE	2
	T-F	4
	DC	2
	C2	4
	DH	4
	F1	343
	F2	37
	F3	32
	V2	104
	F4	4
	GL	1
	SL	38
	M20	1
	ST	2

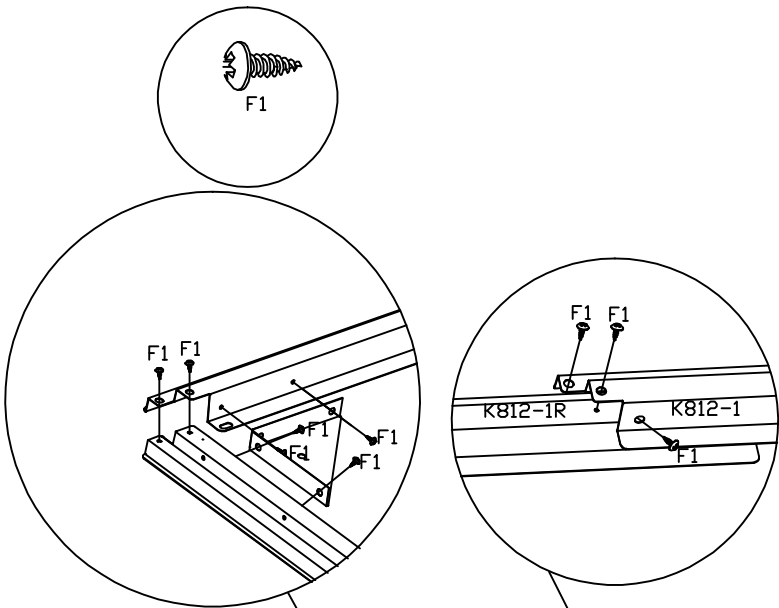



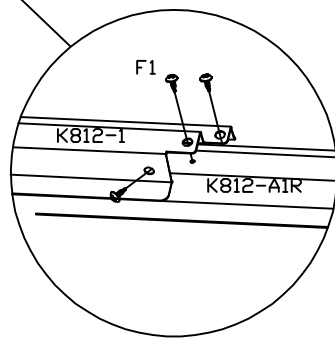
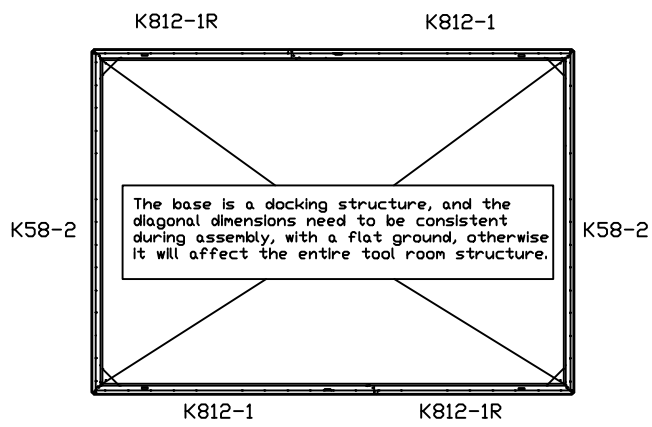
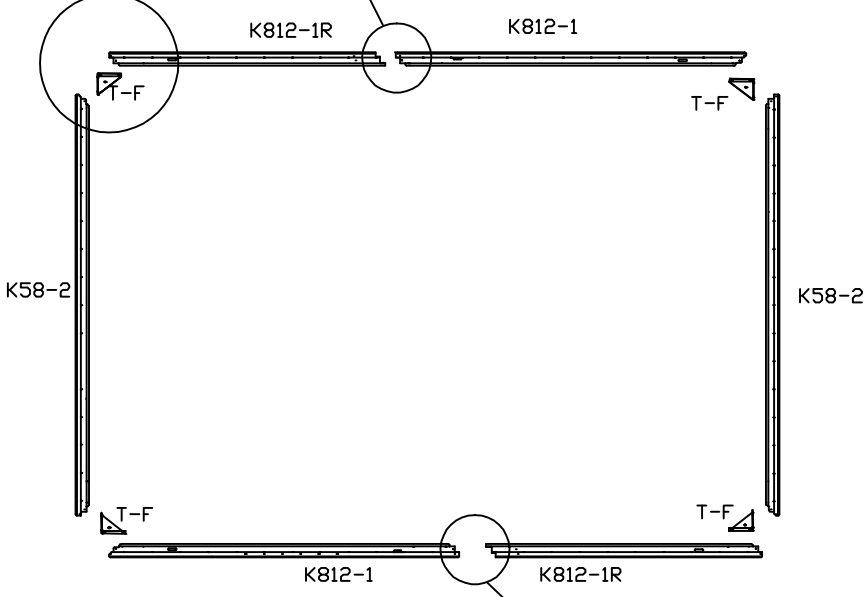



PART	NO.	QTY.
	K812-1	2
	K812-1R	2
	K58-2	2
	T-F	4
	F1	30

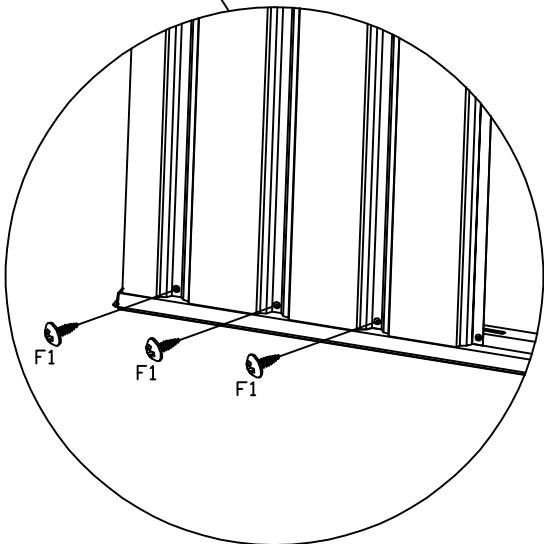
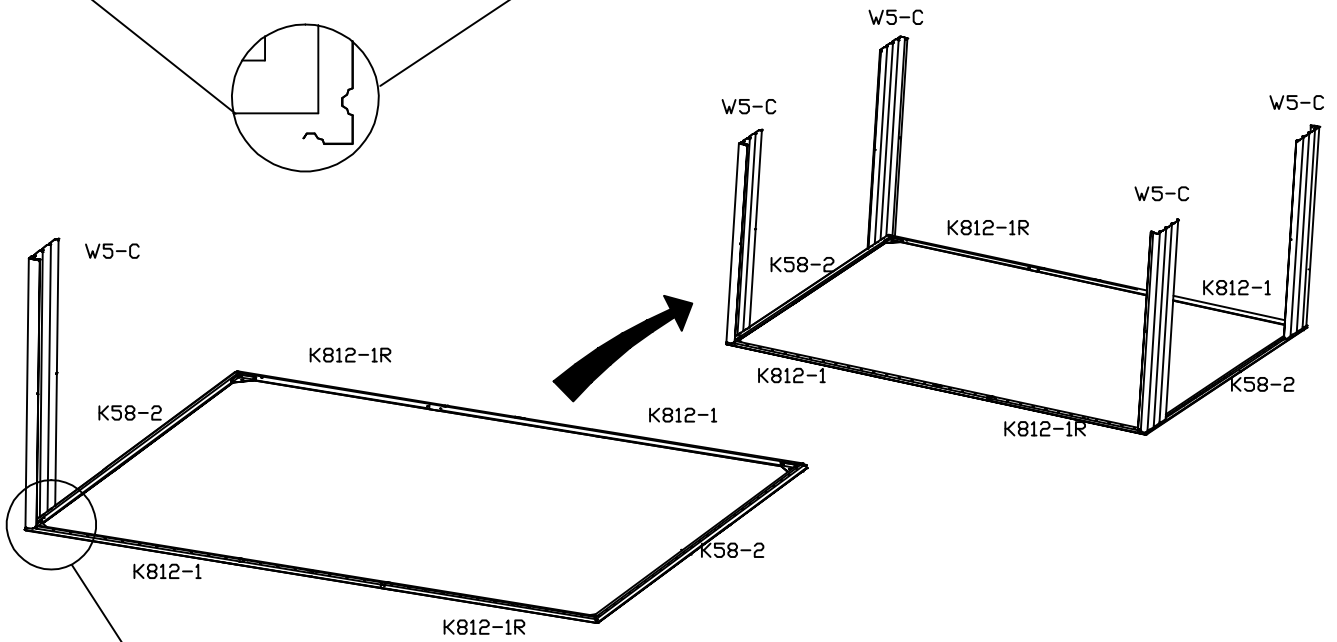
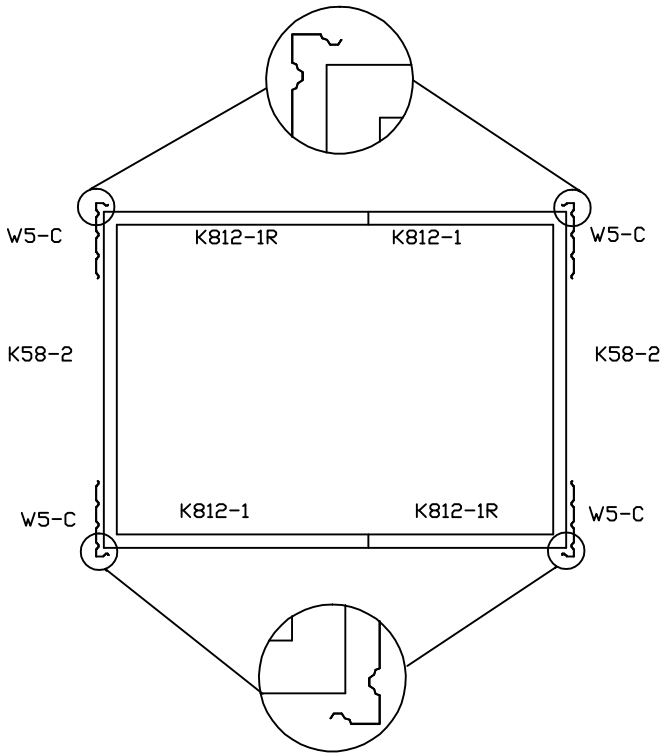



PART	NO.	QTY.
	W5-C	4
	F1	12





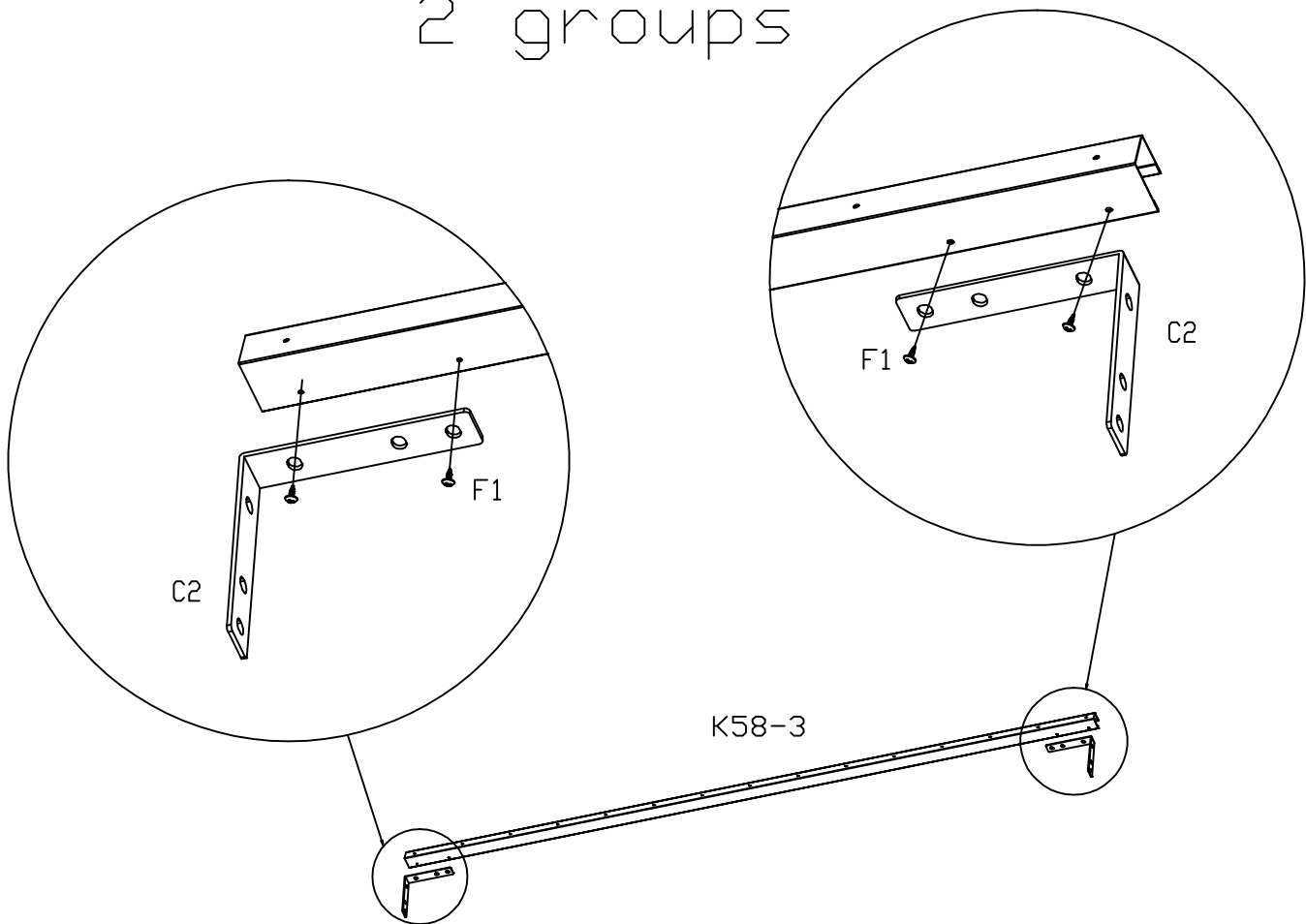

PART	NO.	QTY
	K58-3	2
	C2	4
	F1	8

2 groups

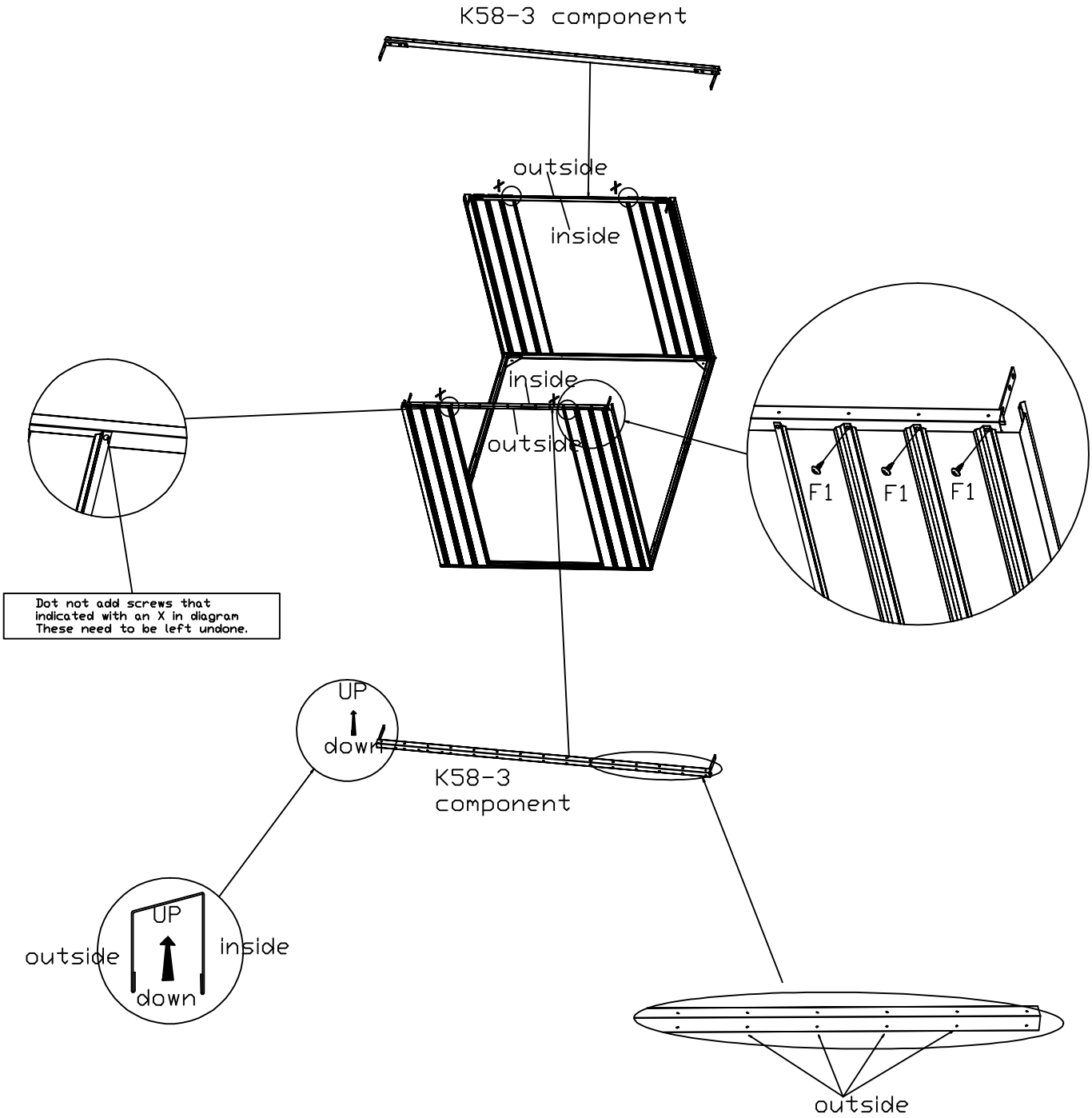





PART	NO.	QTY
	K58-3 component	2
	F1	12

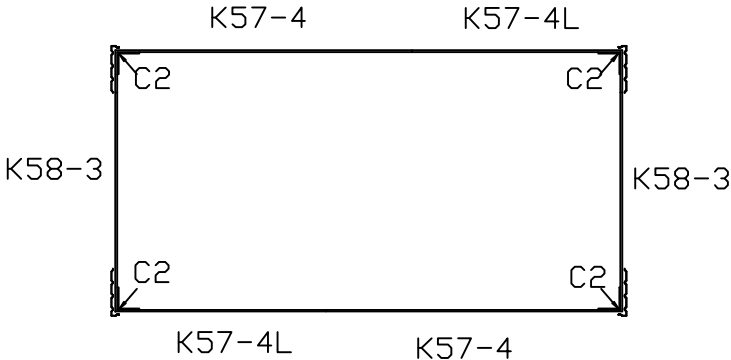
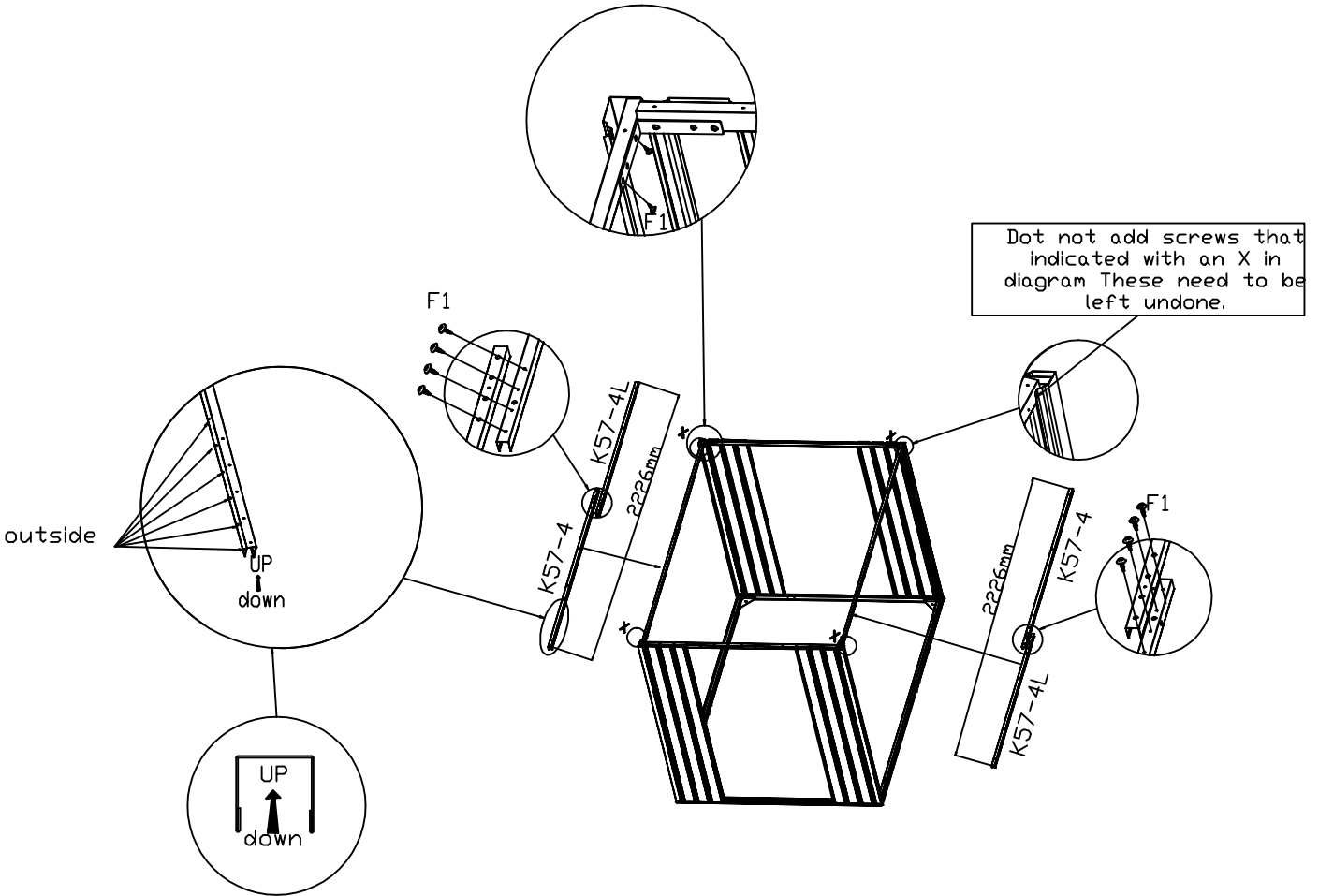

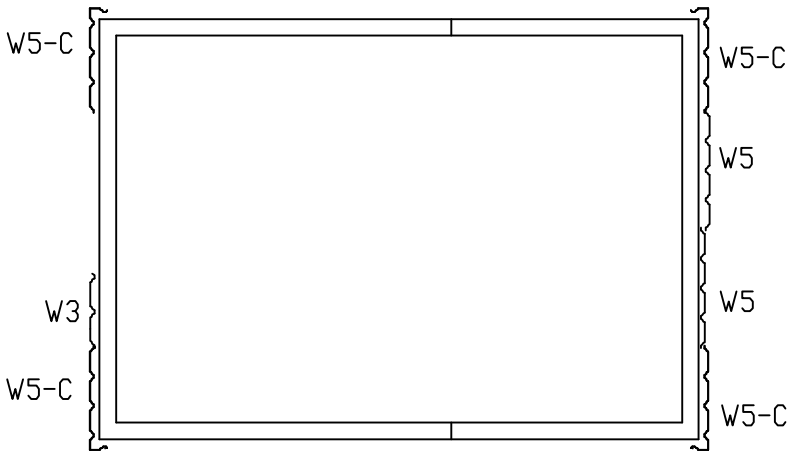
PART	NO.	QTY
	K57-4L	2
	K57-4	2
	F1	16







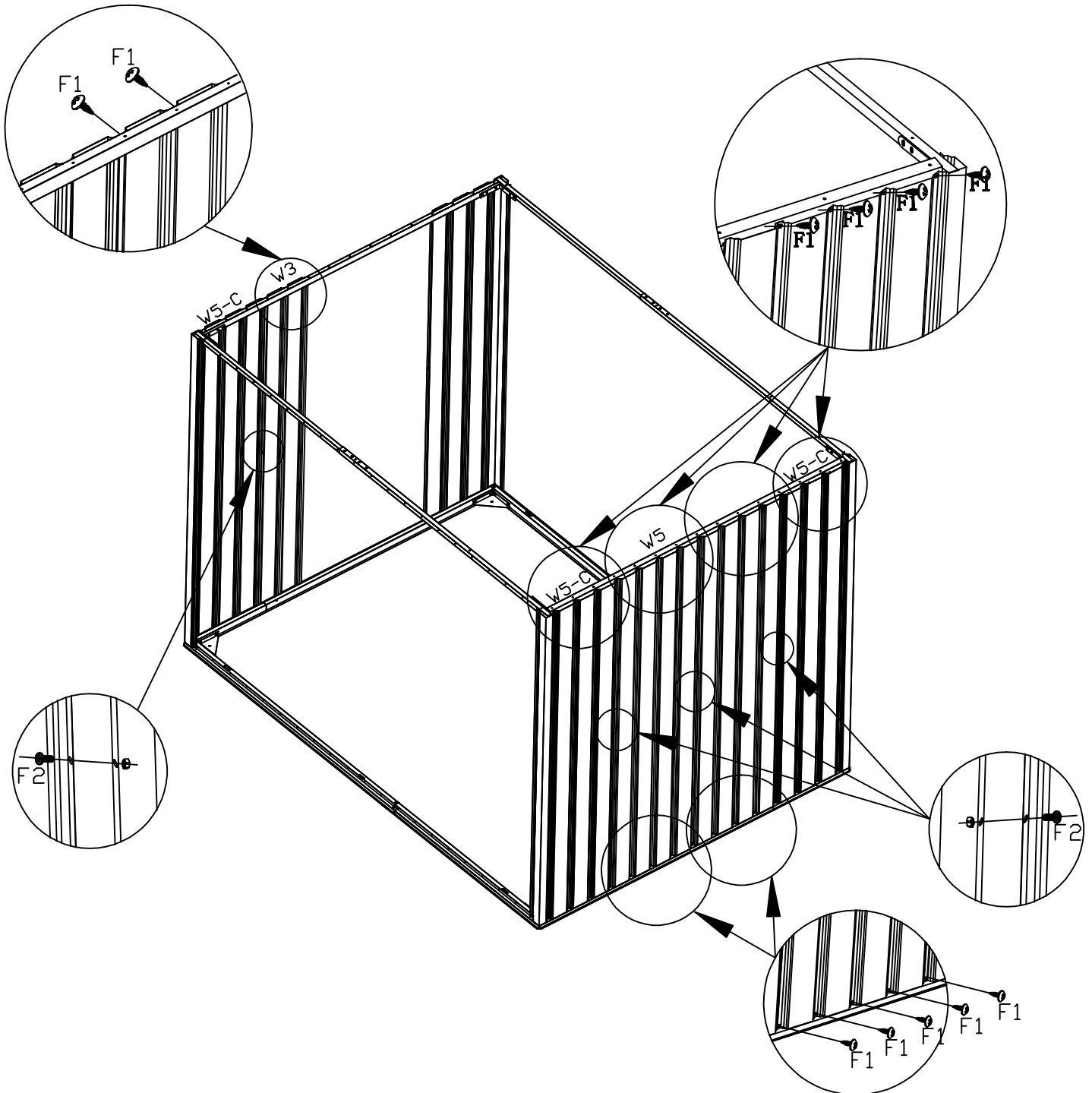

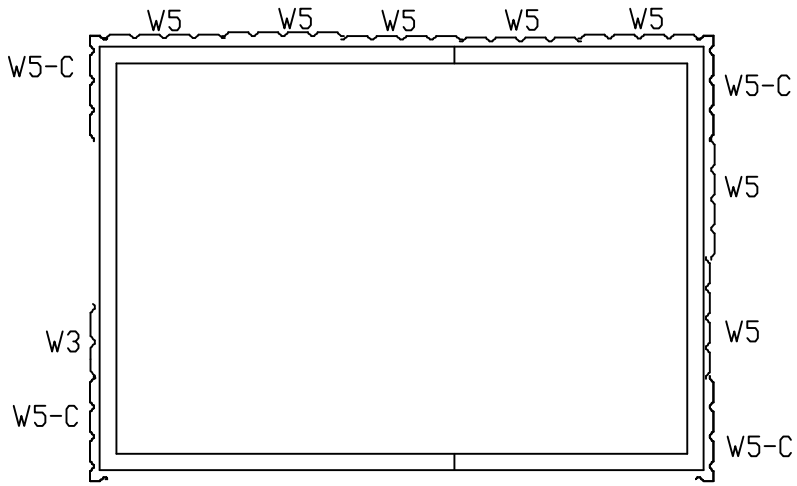
PART	NO.	QTY.
	W5	2
	W3	1
	F1	22
	F2	4



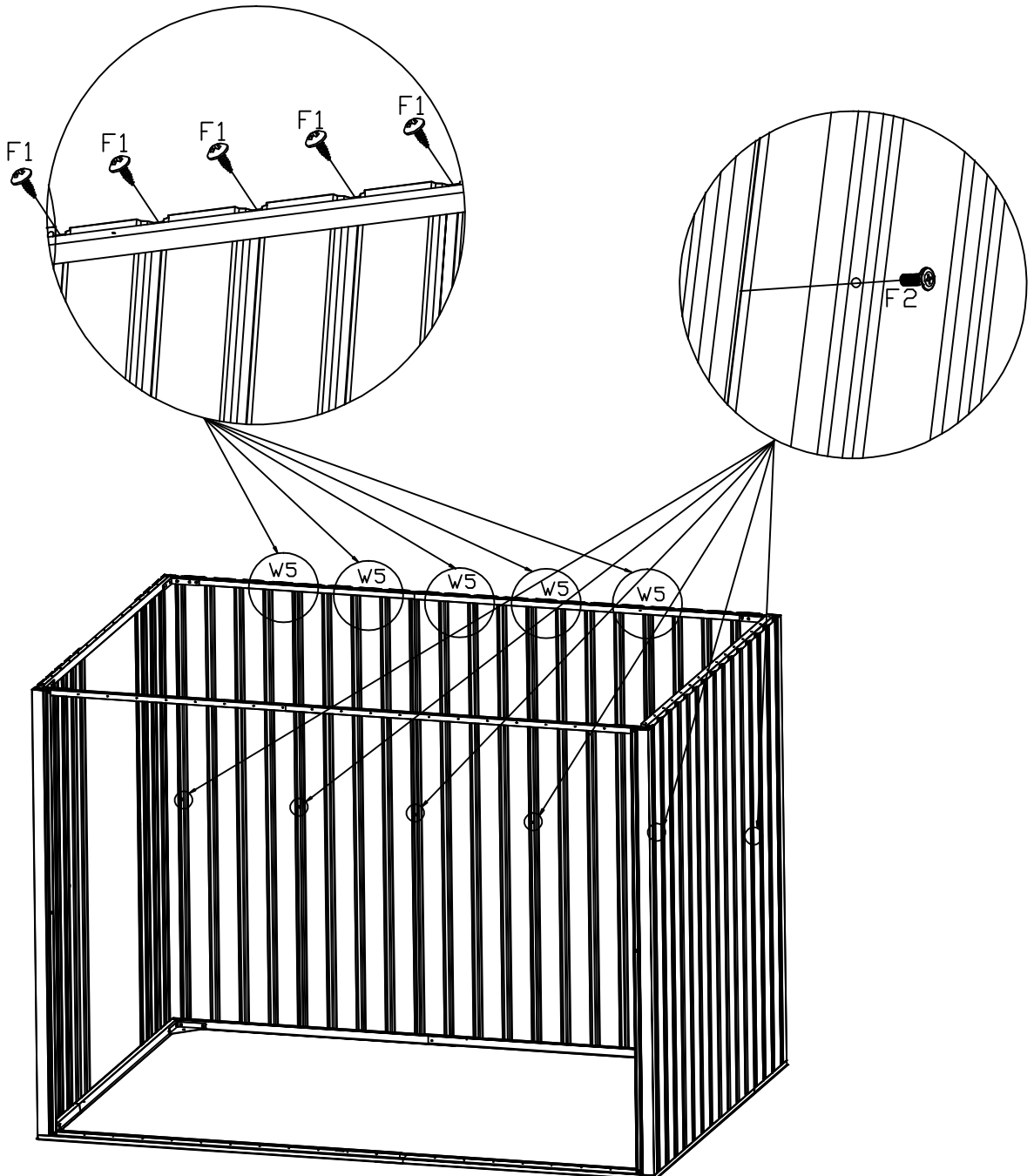





PART	NO.	QTY.
	W5	5
	F1	42
	F2	6

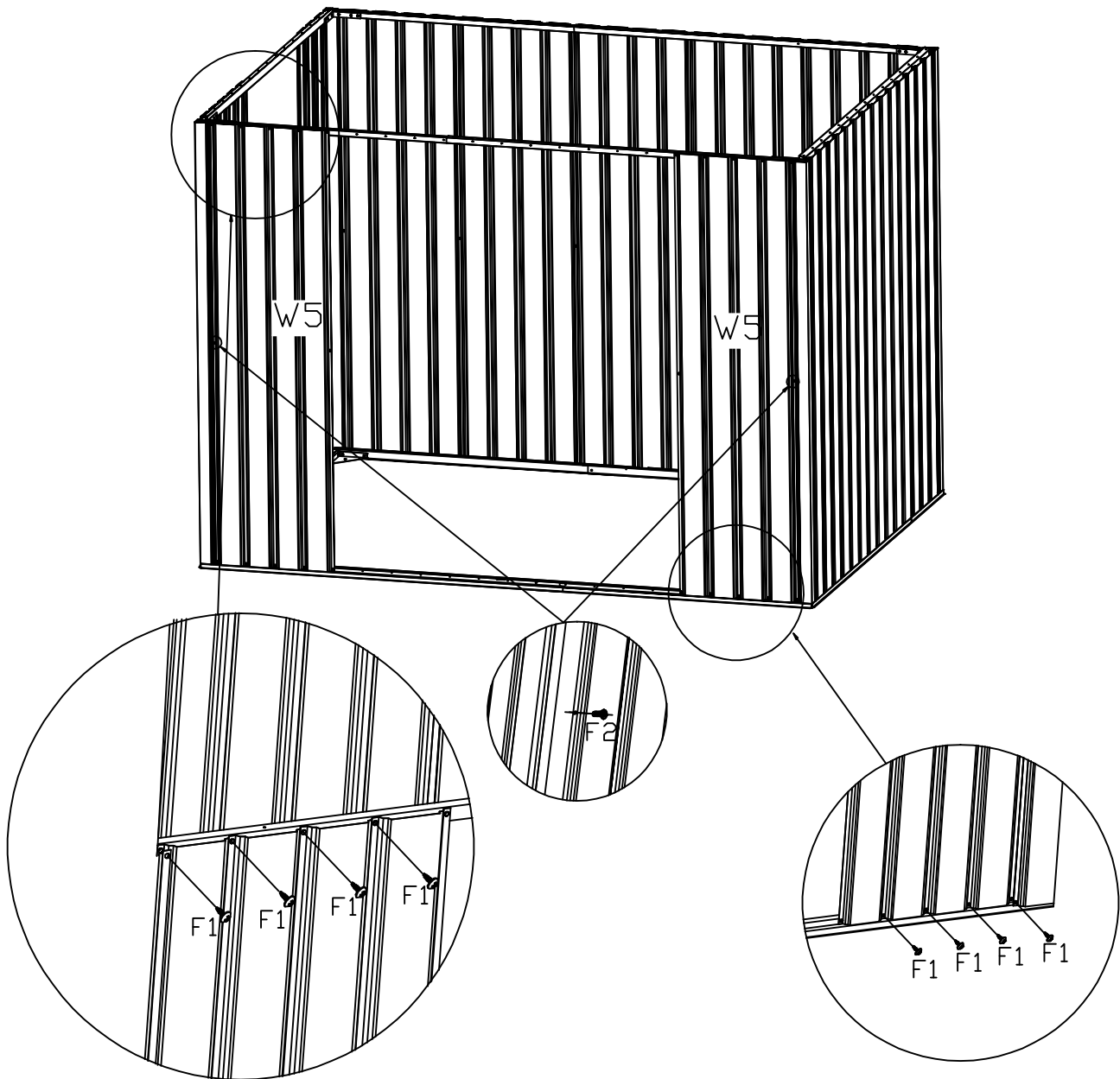
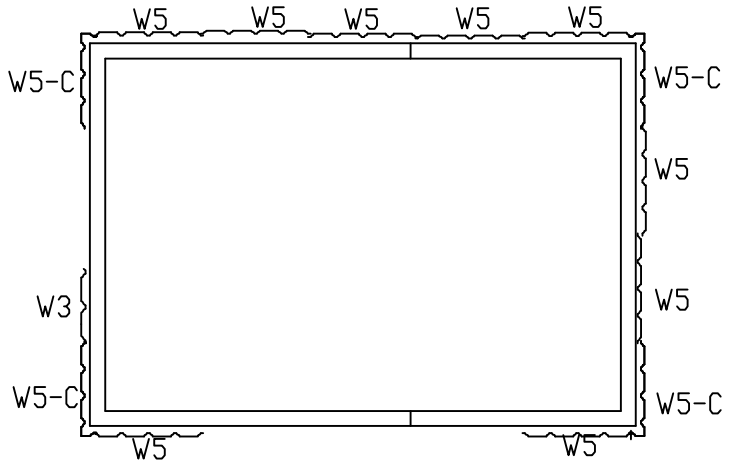

PART	NO.	QTY.
	W5	2
	F1	16
	F2	2



PART	NO.	QTY.
	UA	2
	F1	8
	F2	2

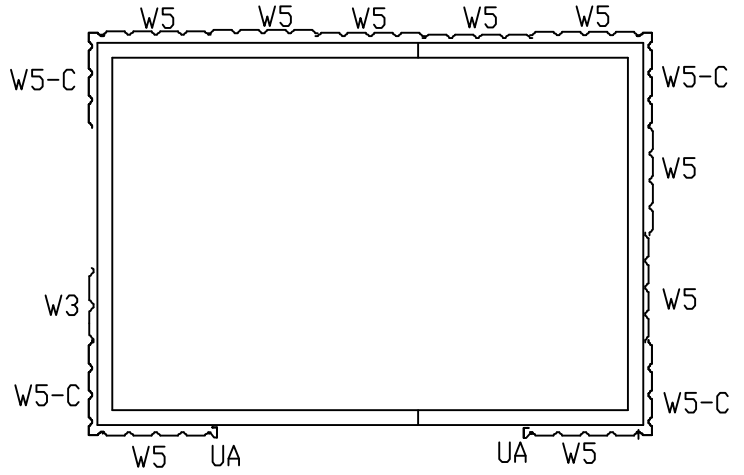

① UA notch is inserted into K57-4L/K57-4.

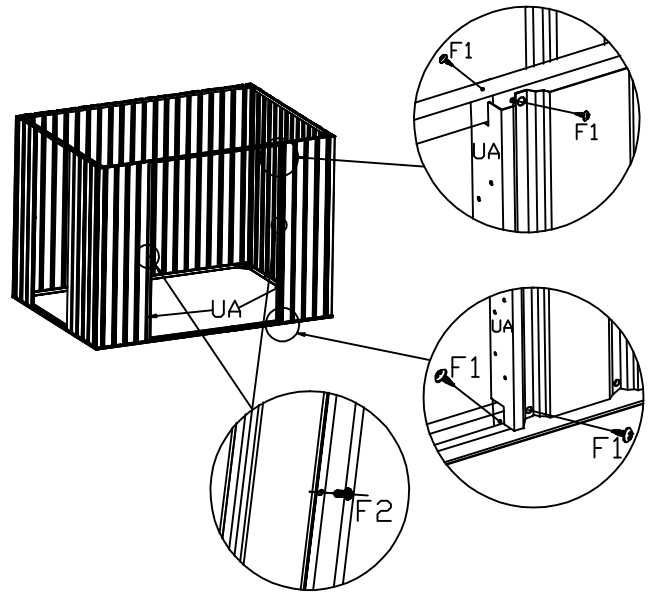
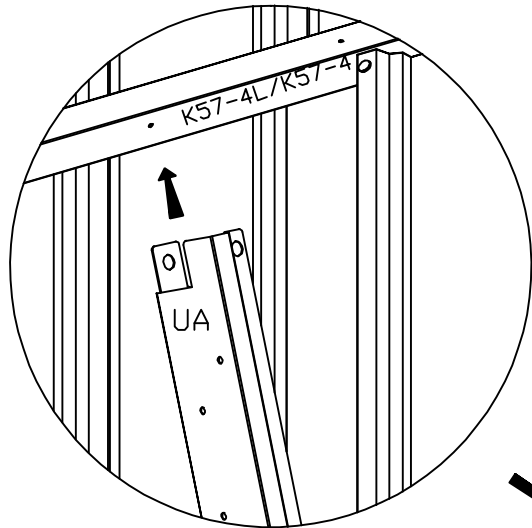

④ F1 screw fixation

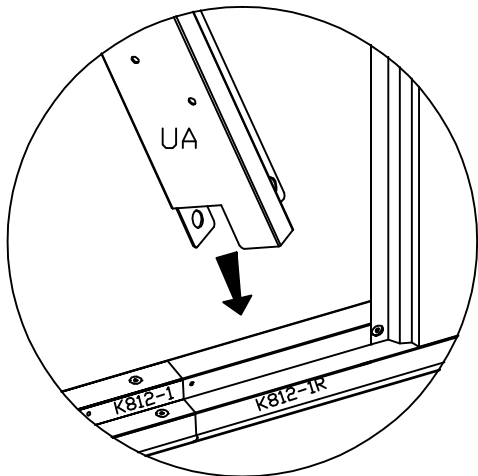



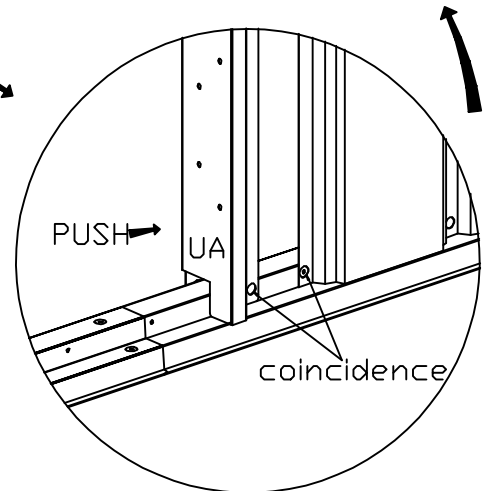

② UA notch is inserted into K812-1/K812-1R.

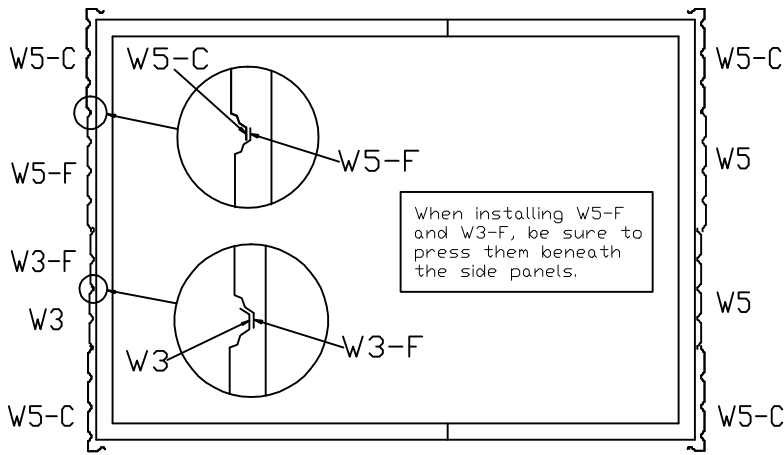



③ Push UA and W5 screw holes to coincide.



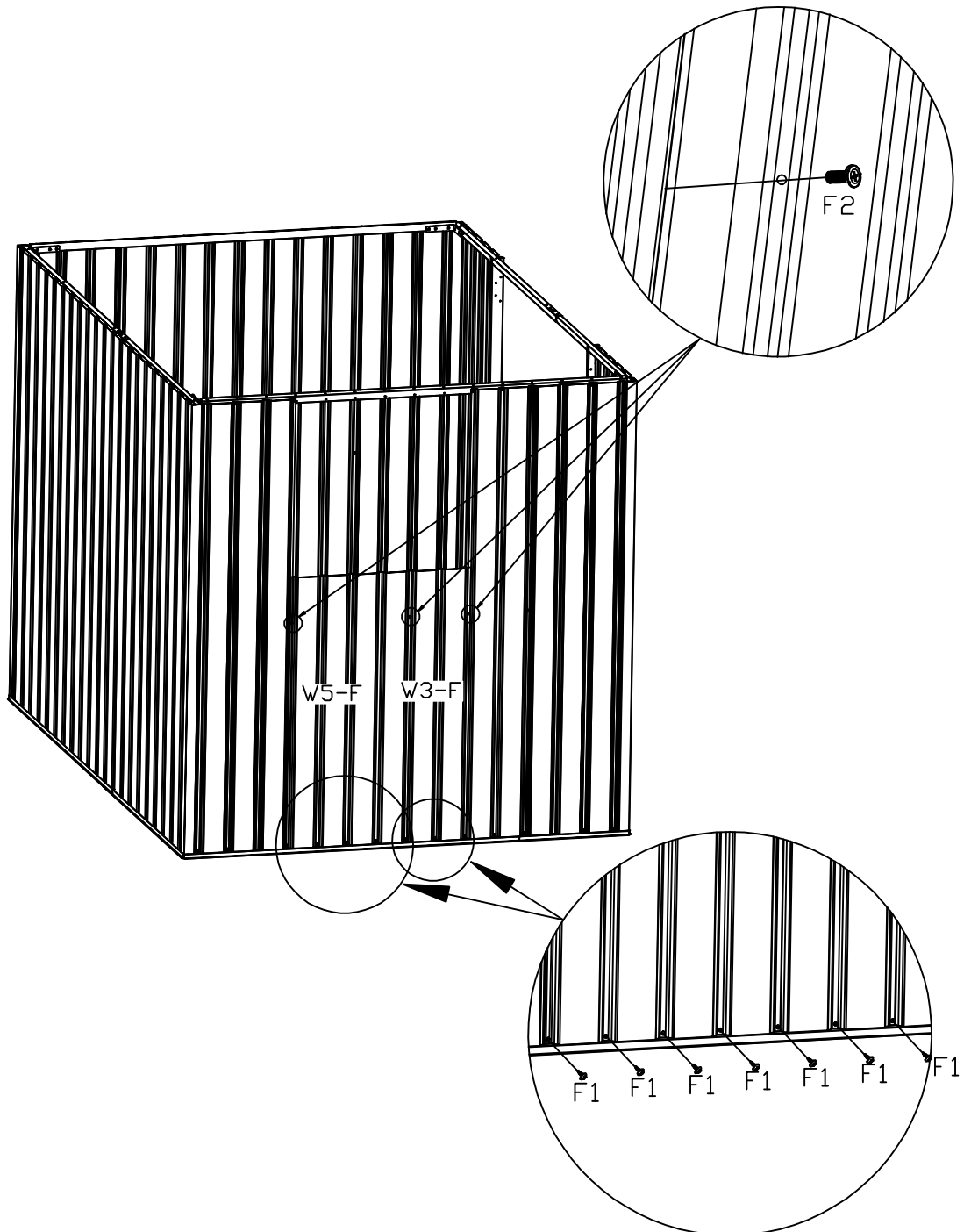

PART	NO.	QTY.
	W5-F	1
	W3-F	1
	F1	7
	F2	3

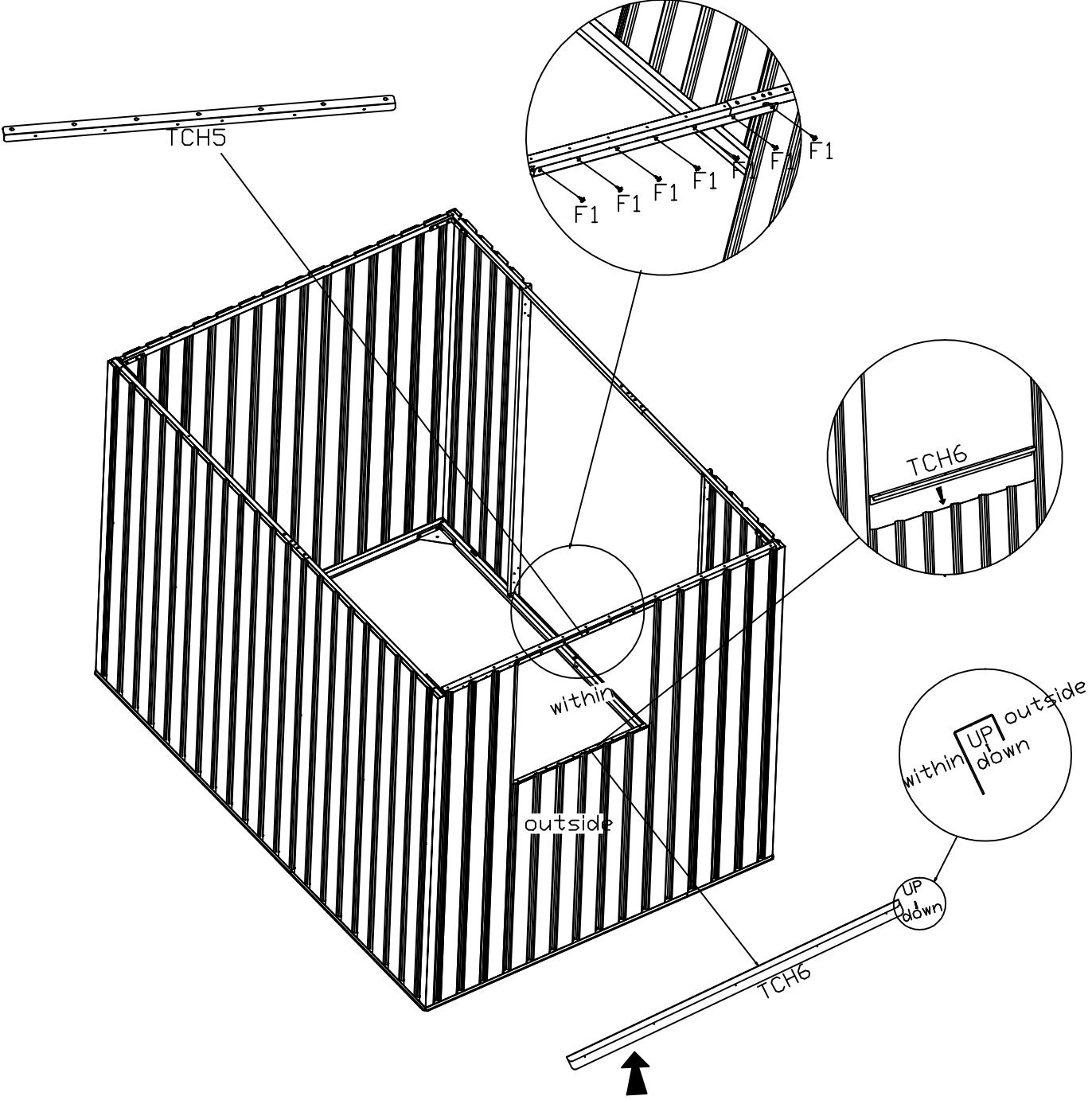

PART	NO.	QTY.
	TCH5	1
	TCH6	1
	F1	7





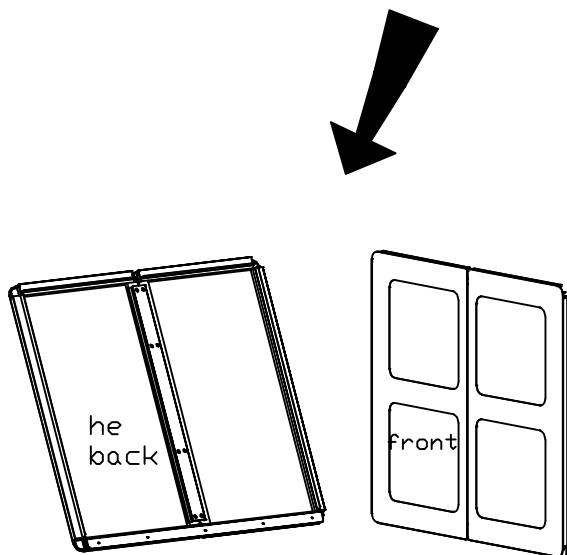
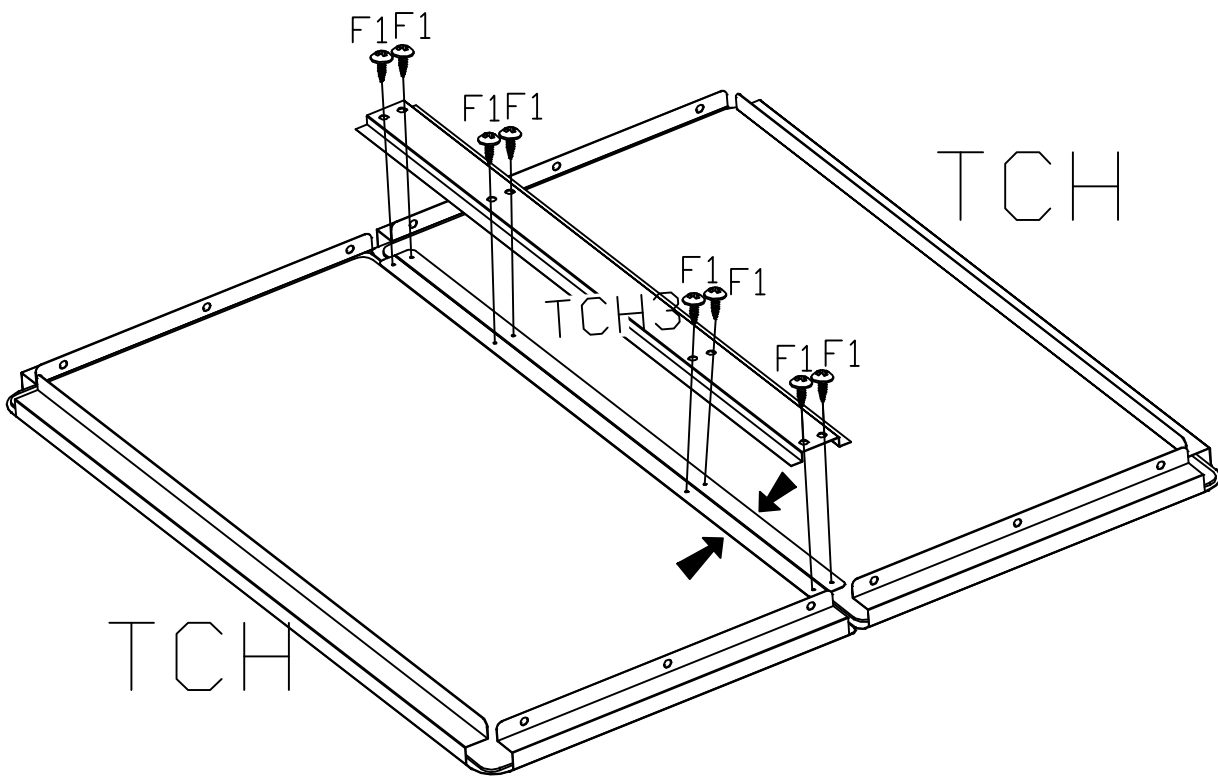

Installation method: Clip the TCH6 slot onto W5-F and W3-F, with the long side facing inward, without the need for screws to secure.

PART	NO.	QTY.
	TCH	2
	TCH3	1
	F1	8

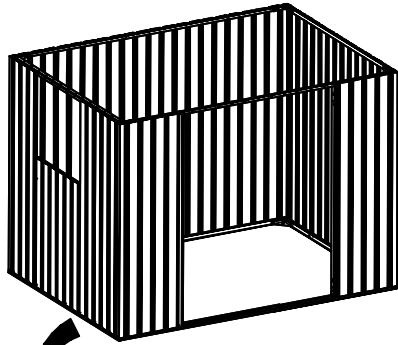
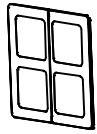



TCH



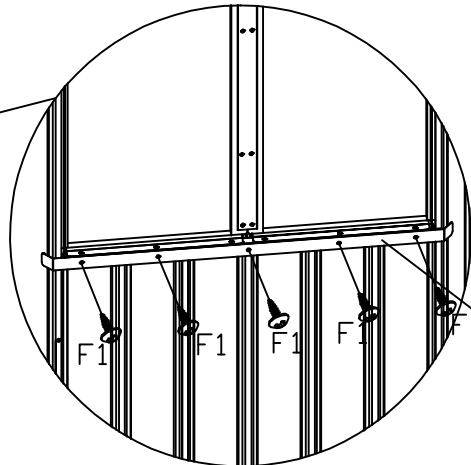
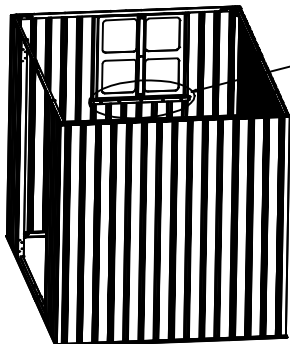
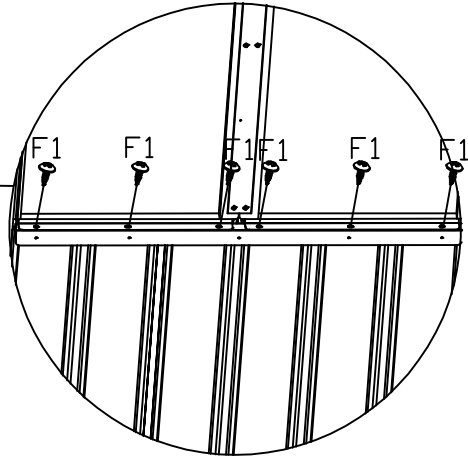
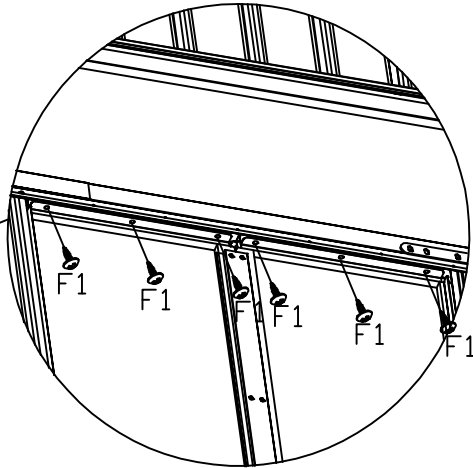
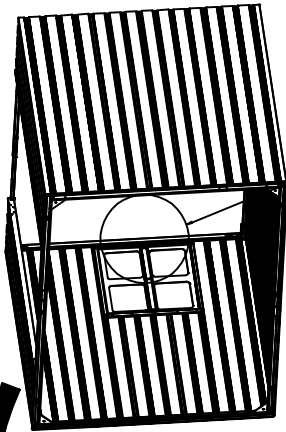

PART	NO.	QTY.
	Window components	1
	TCH7	1
	F1	17

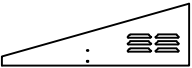
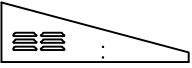



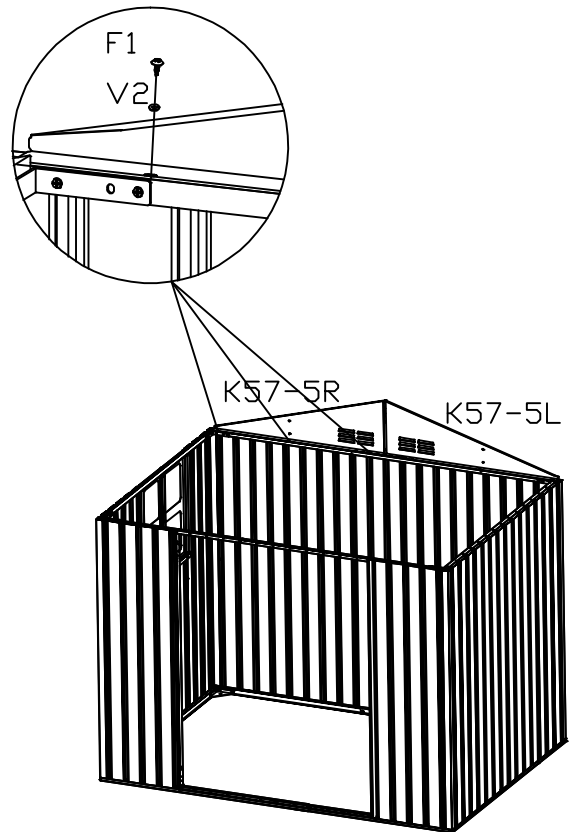
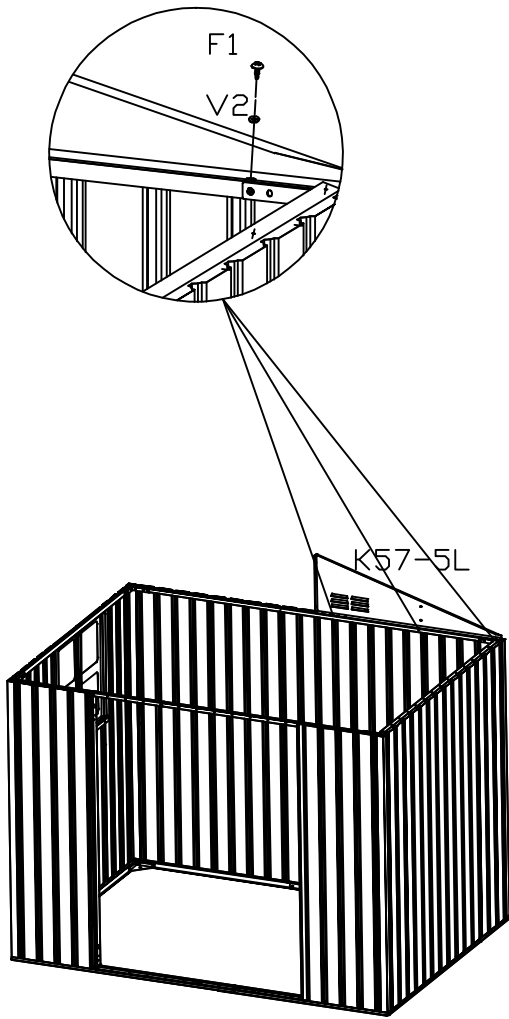

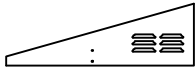
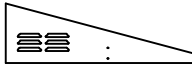
TCH7

PART	NO.	QTY.
	K57-5L	2
	K57-5R	2
	F1	6
	V2	6

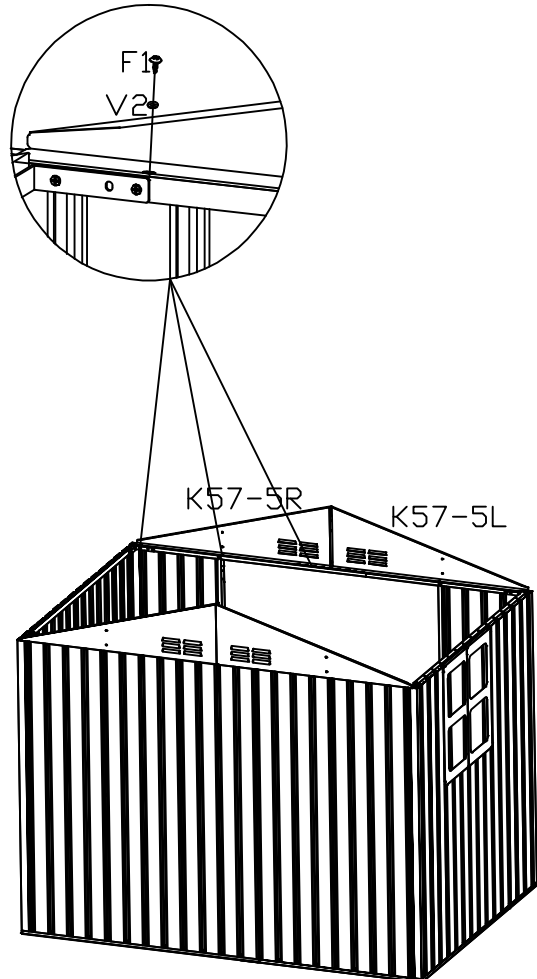
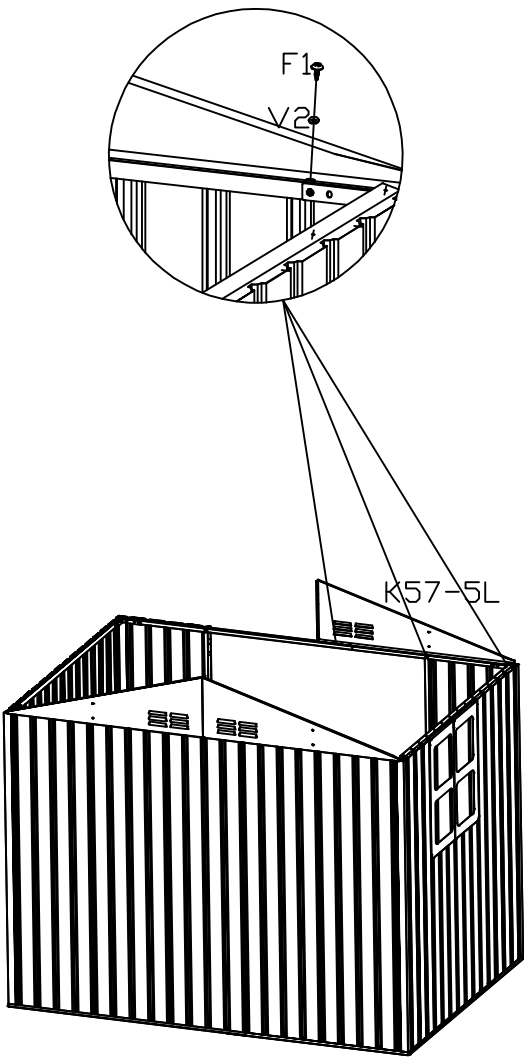

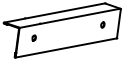

PART	NO.	QTY.
	K57-5L	1
	K57-5R	1
	F1	6
	V2	6

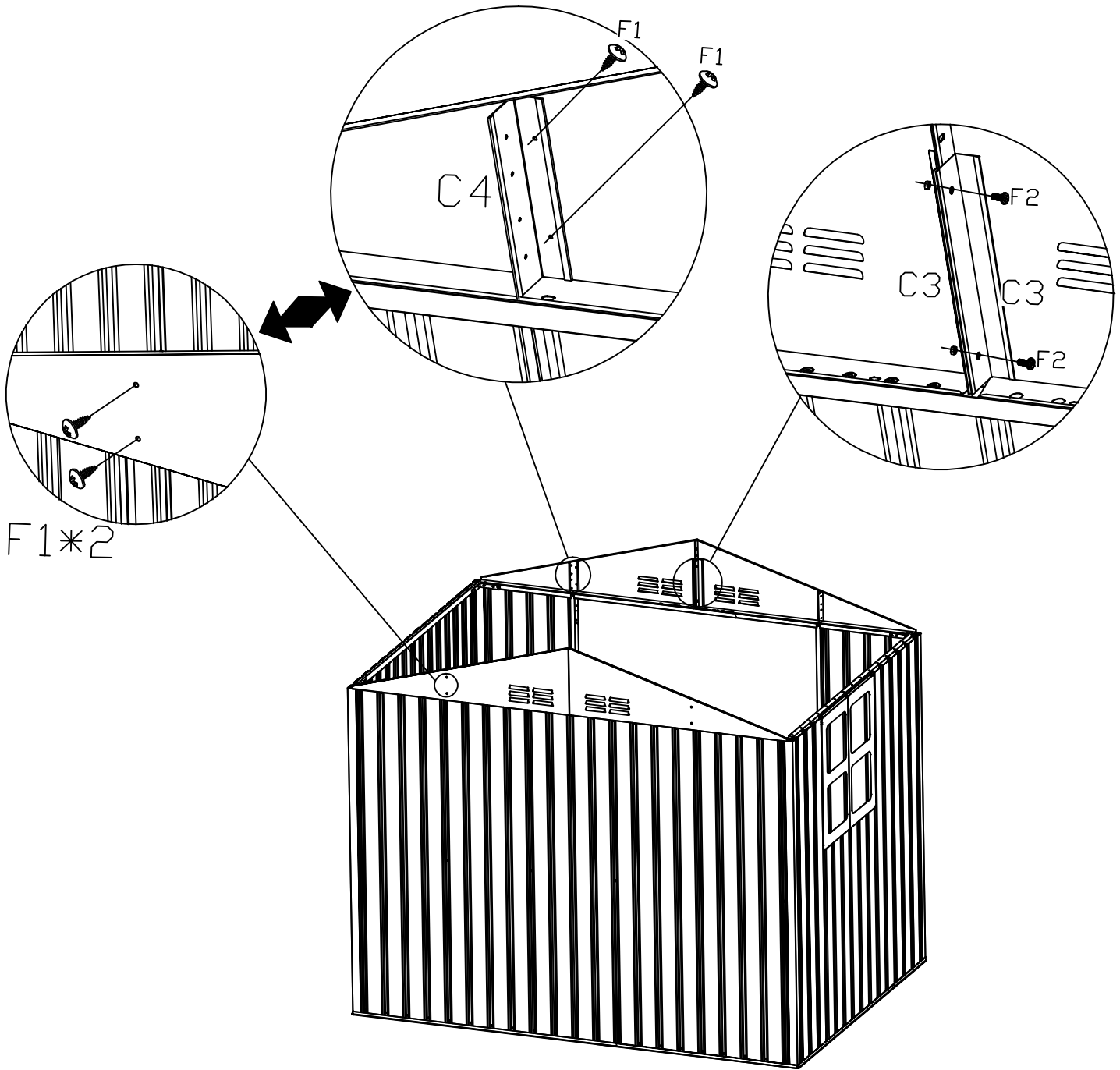
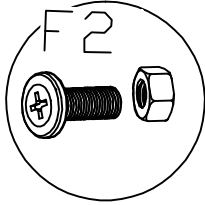

PART	NO.	QTY.
	C3	4
	C4	4
	F2	4
	F1	8





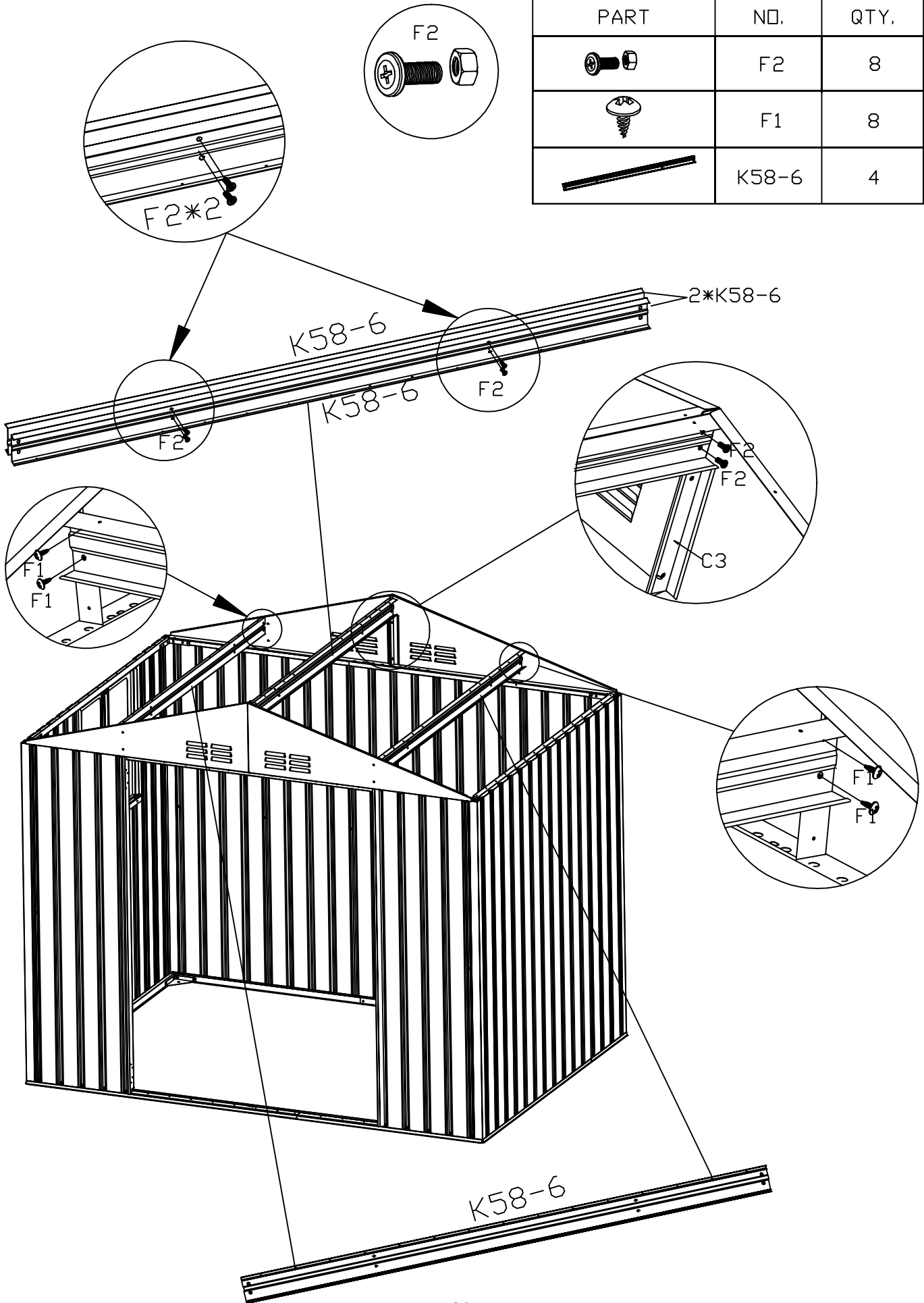

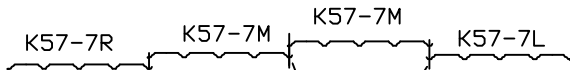
PART	NO.	QTY.
	F2	8
	F1	8
	K58-6	4



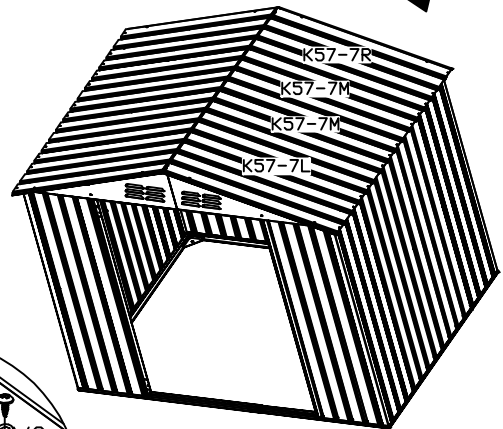
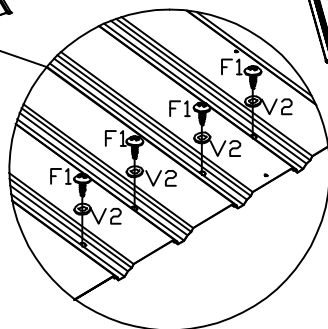
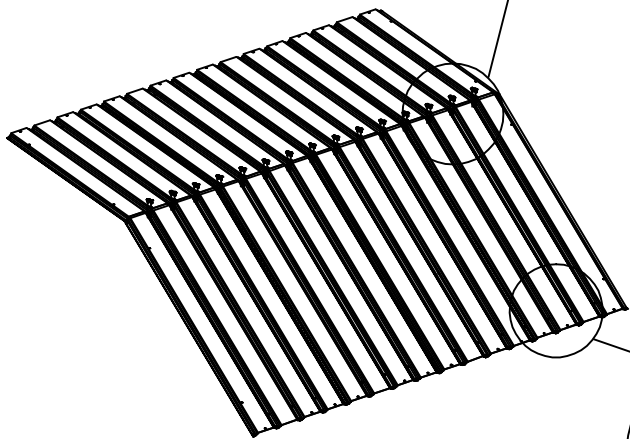
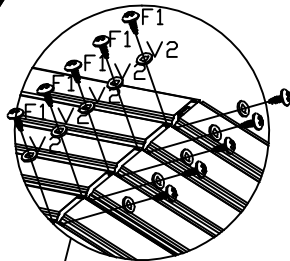
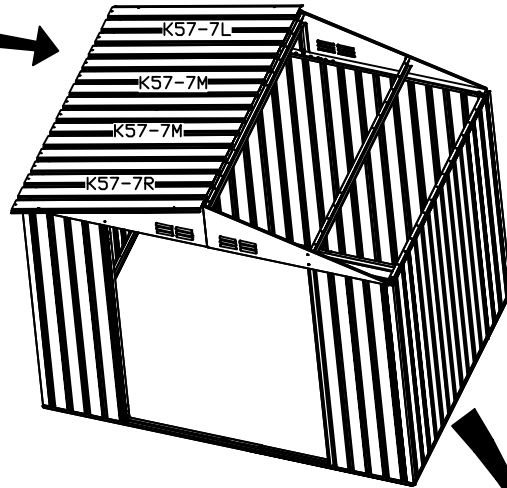
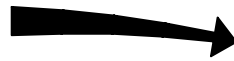
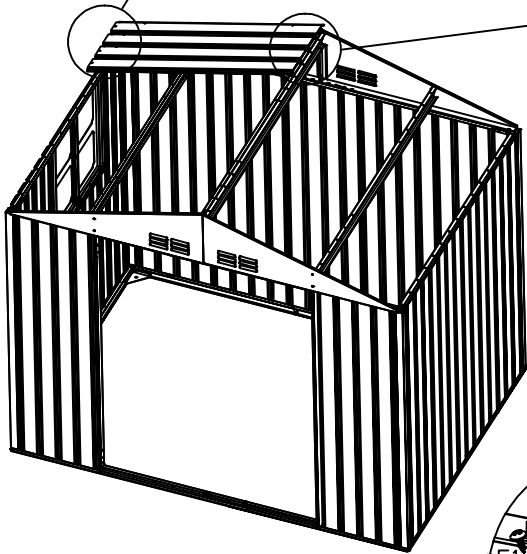
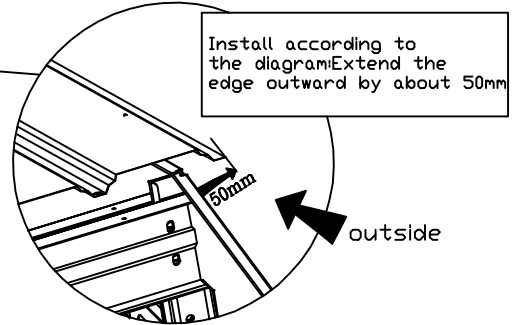
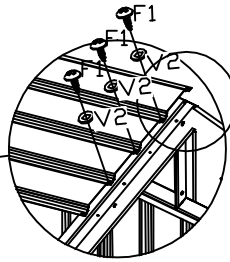
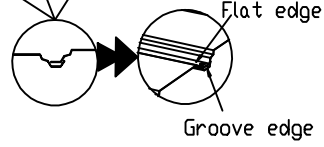
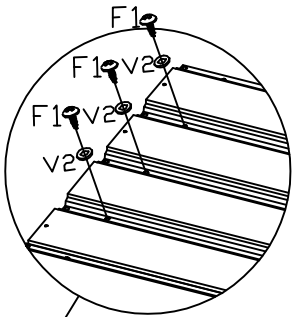





PART	NO.	QTY.
	K57-7L	2
	K57-7M	4
	K57-7R	2
	F1	60
	V2	60

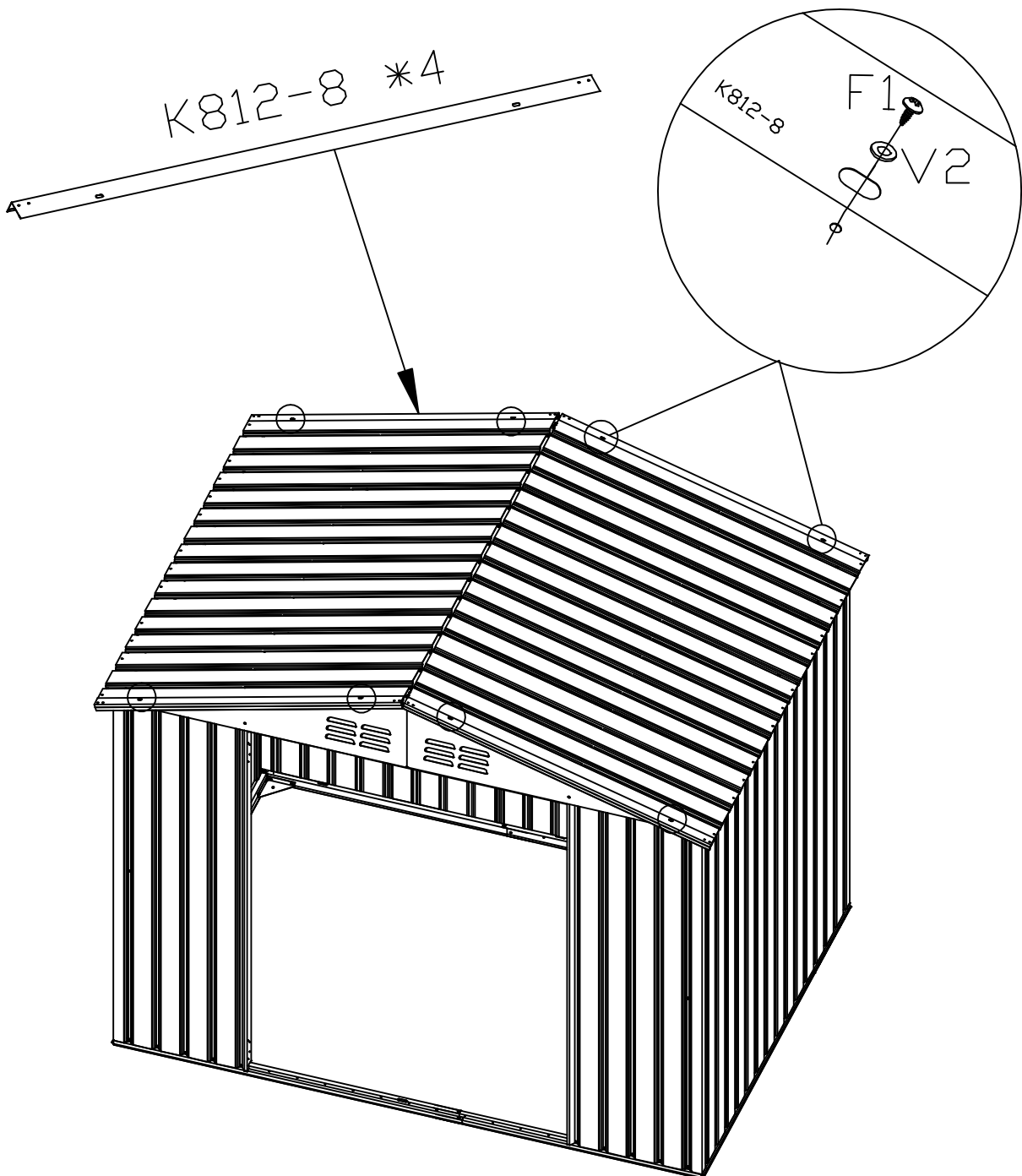





PART	NO.	QTY.
	K812-8	4
	F1	8
	V2	8

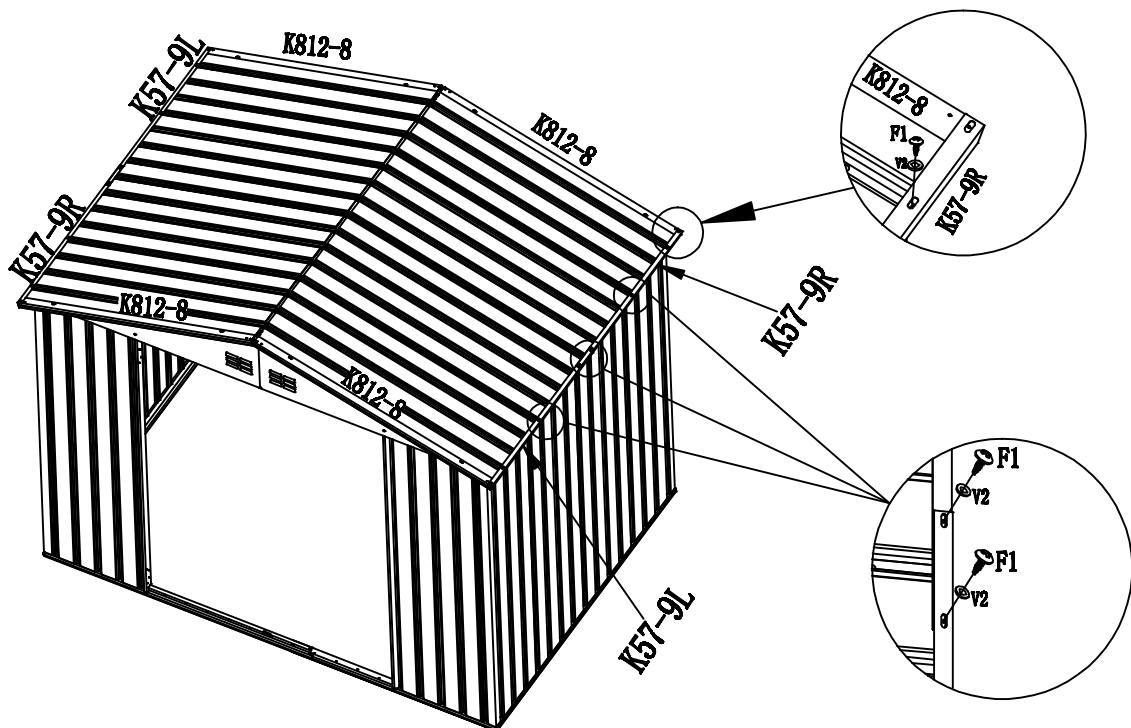
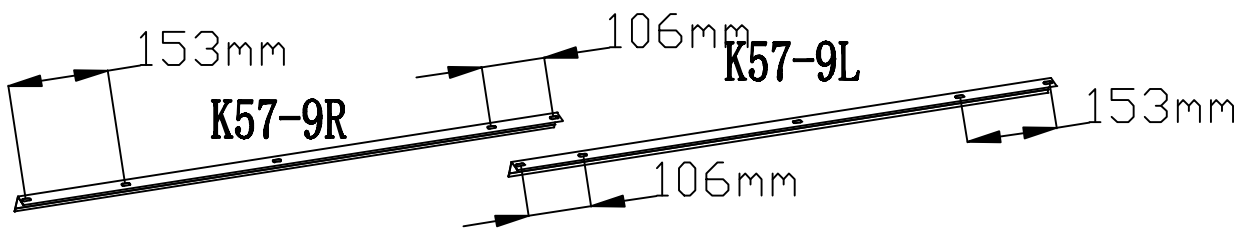

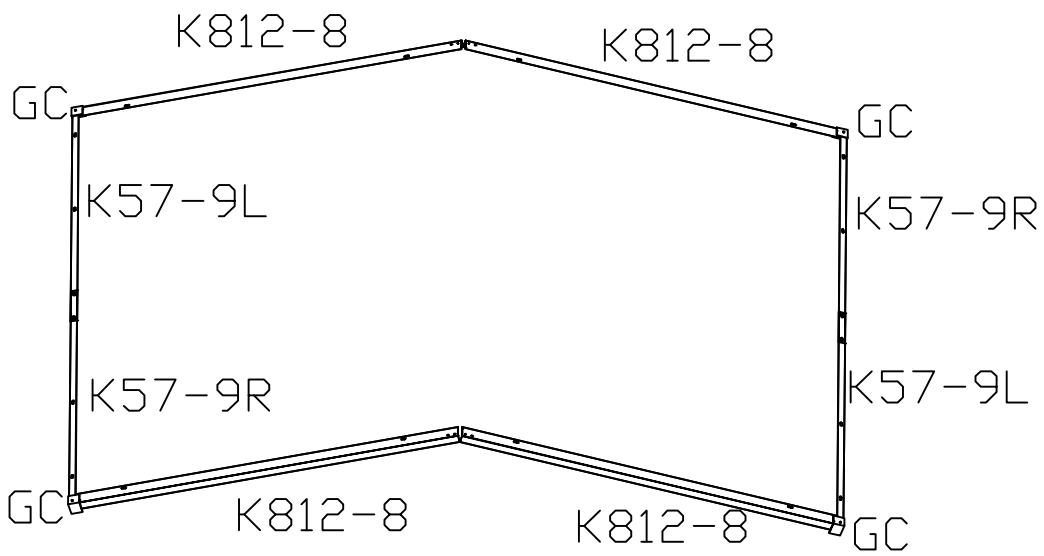



PART	NO.	QTY.
	K57-9L	2
	K57-9R	2
	F1	12
	V2	12



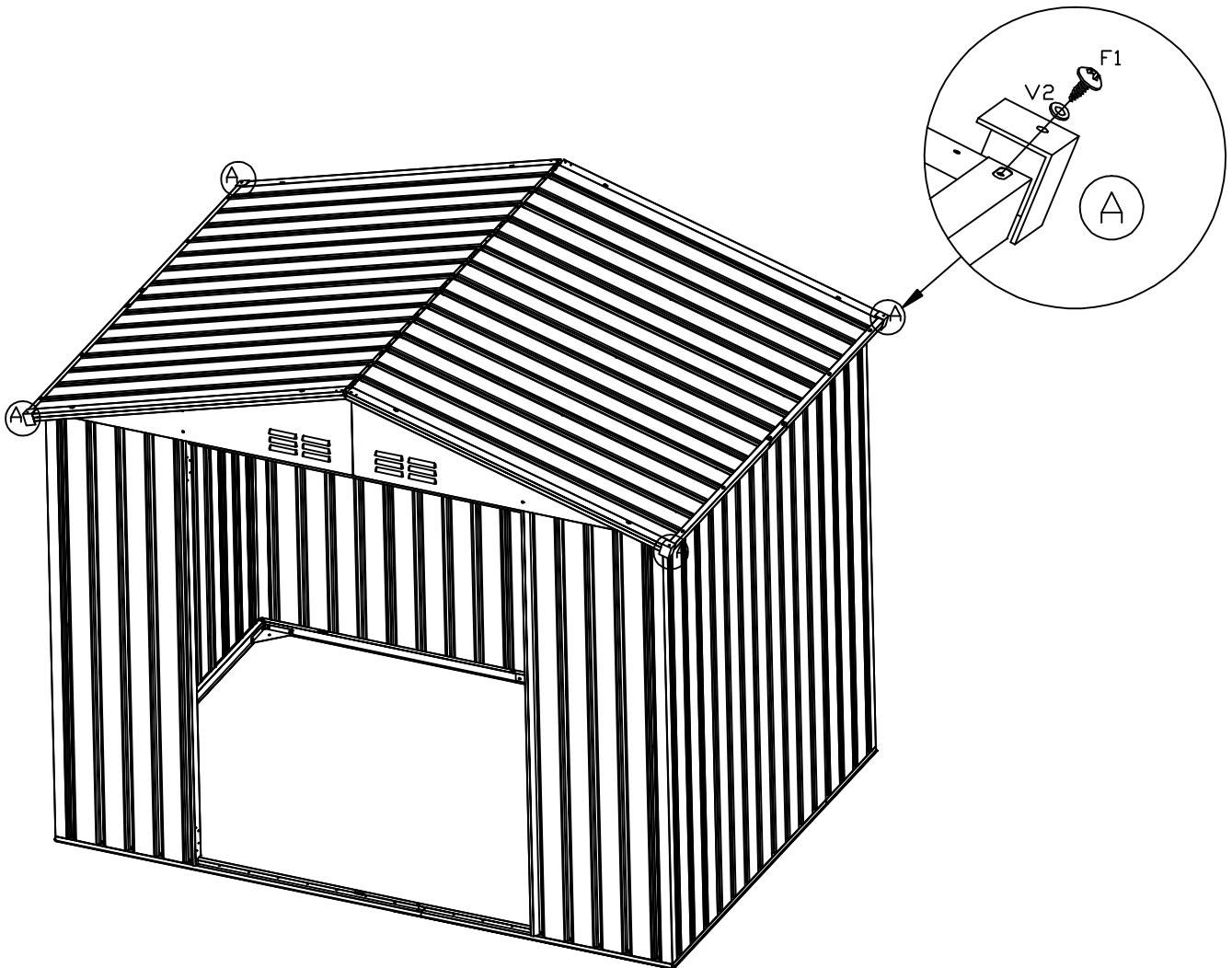

PART	NO.	QTY.
	GC	4
	F1	4
	V2	4



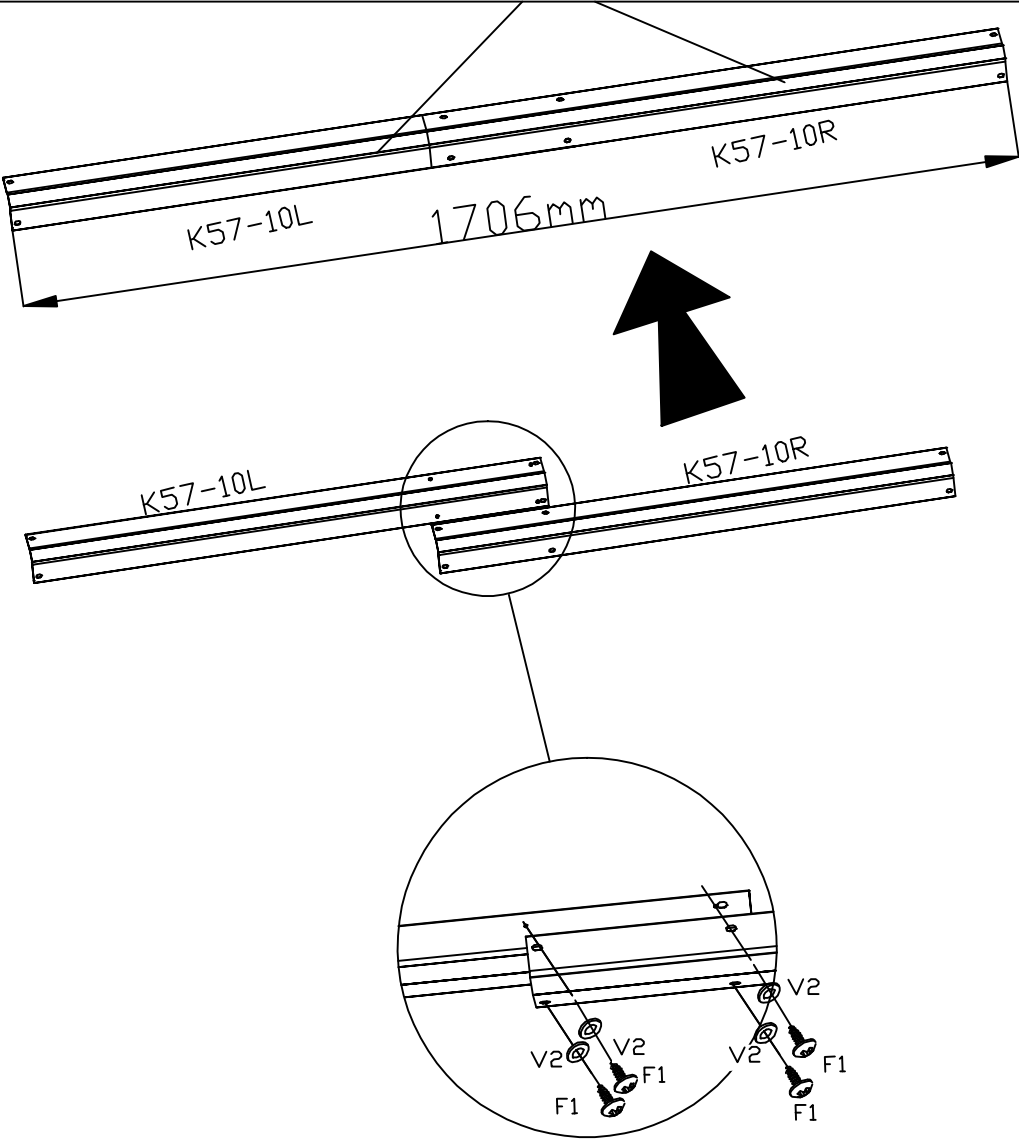

PART	NO.	QTY.
	K57-10L	1
	K57-10R	1
	F1	4
	V2	4

According to the diagram, the two components of the roof rain shield should be connected with F1 self tapping screws before proceeding with subsequent installation.

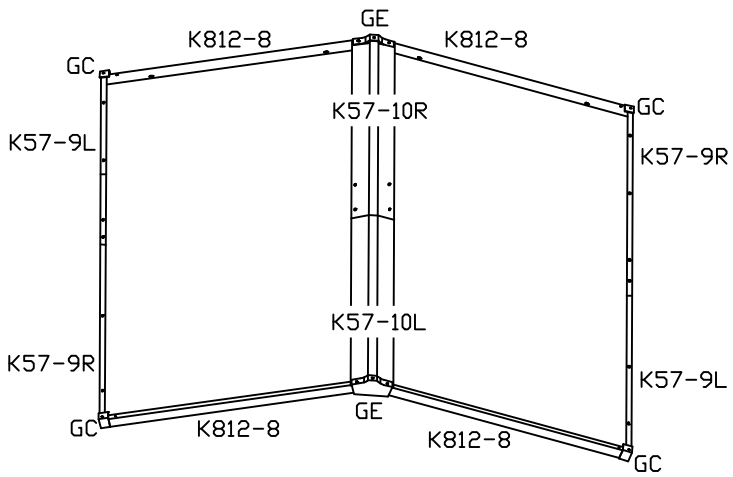



PART	NO.	QTY.
	GE	2
	F4	4
	V2	4

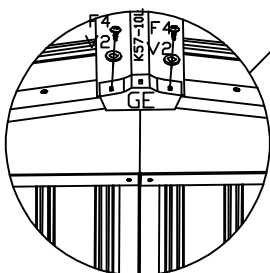
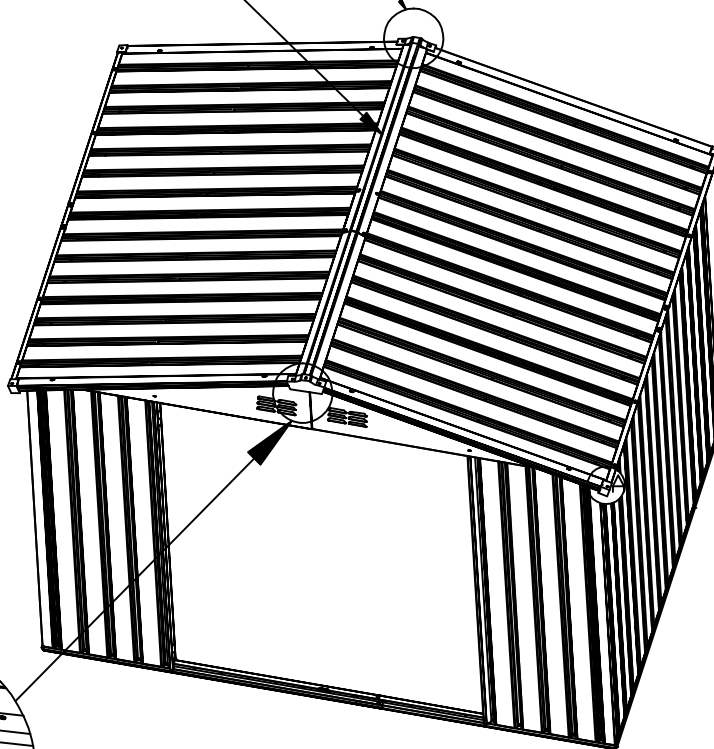
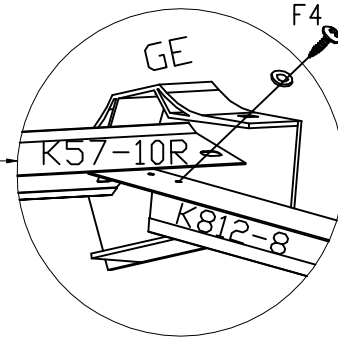
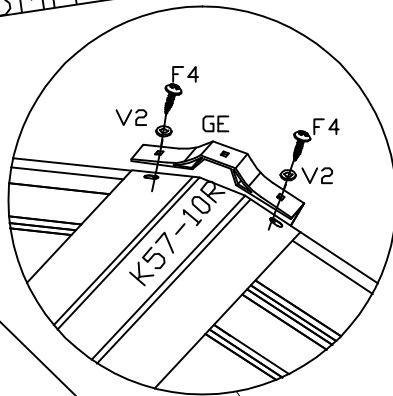
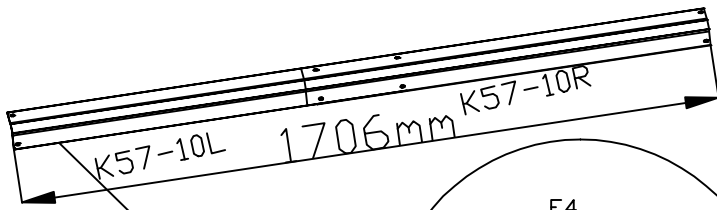

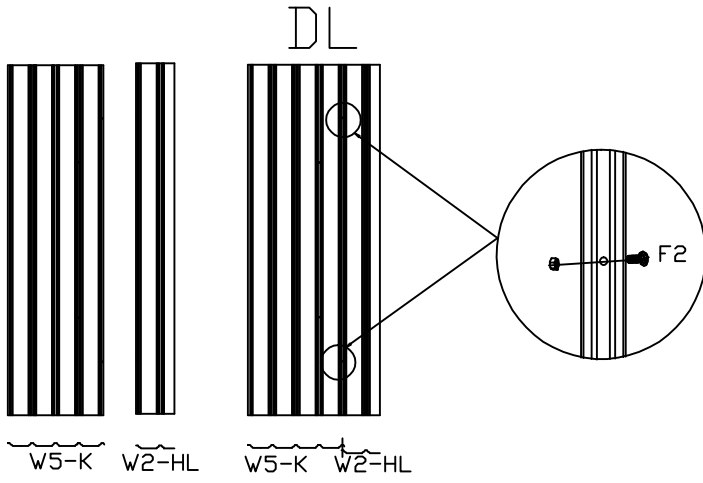

Left door panel splicing

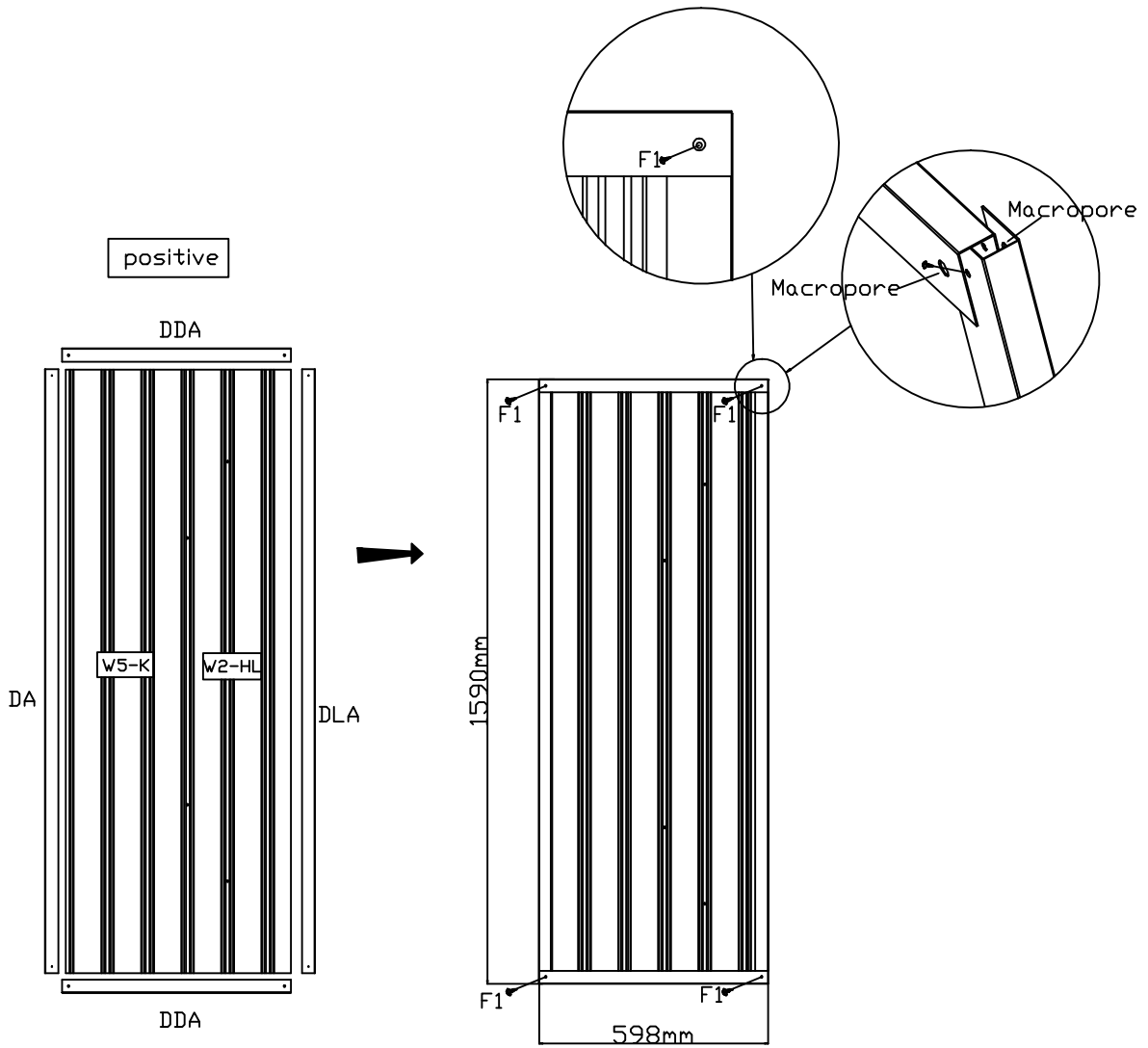

PART	NO.	QTY.
	W5-K	1
	W2-HL	1
	DA	1
	DLA	1
	DDA	2
	F1	4
	F2	2



Left door panel splicing

PART	NO.	QTY.
	DBA	2
	F1	5
	F2	2

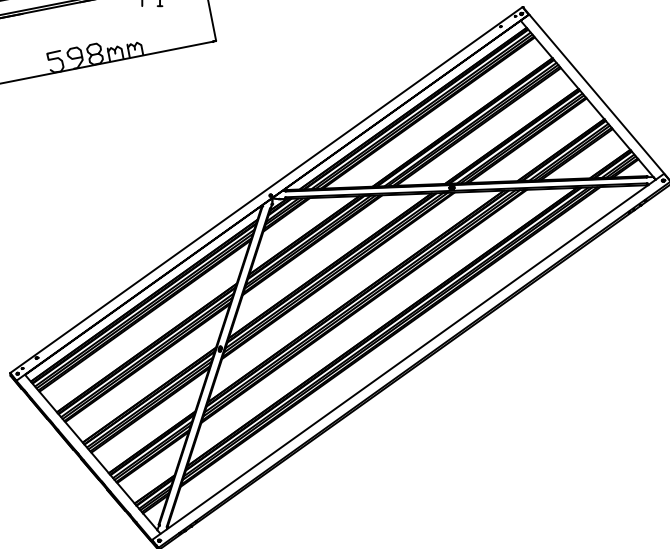
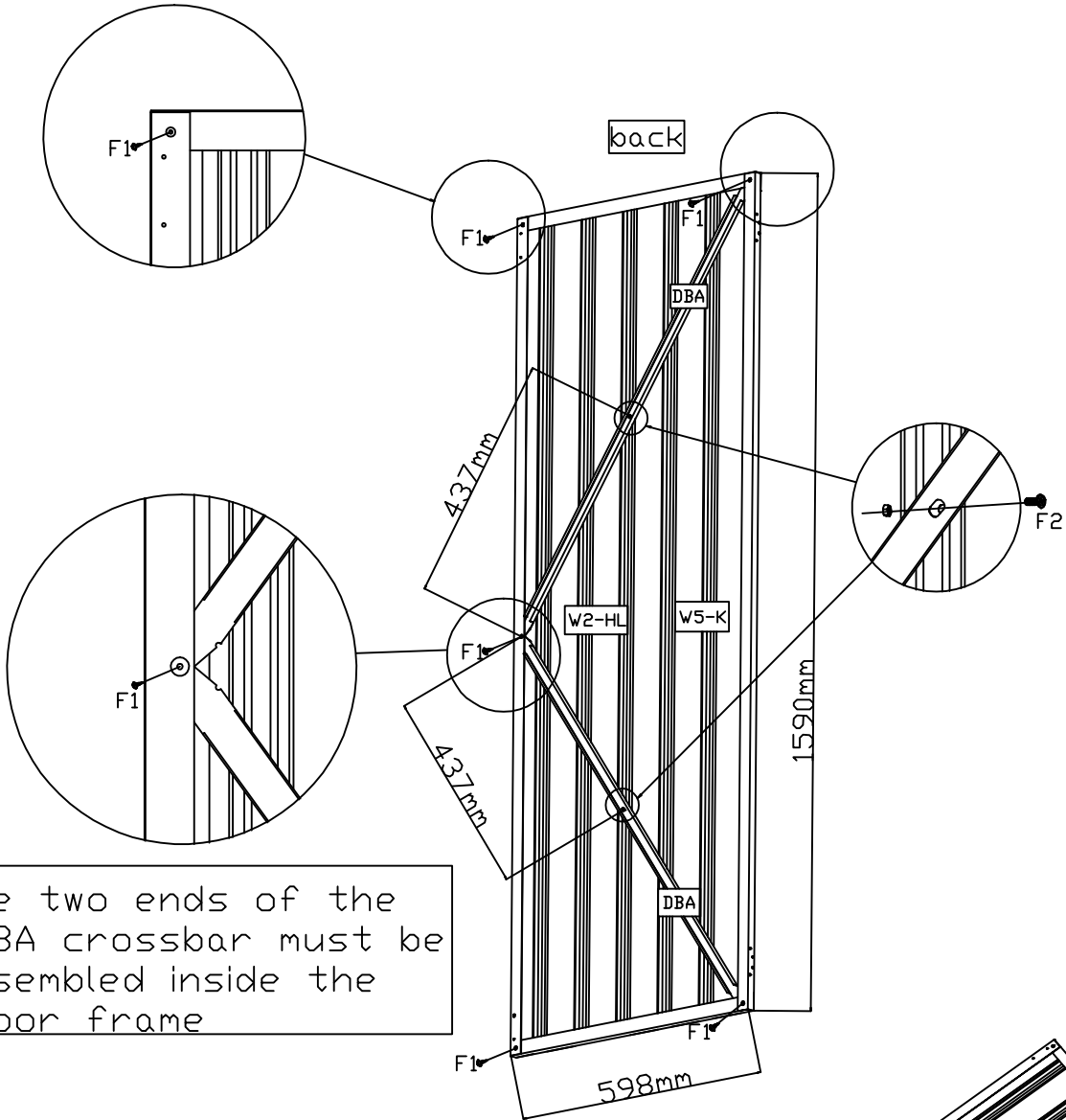

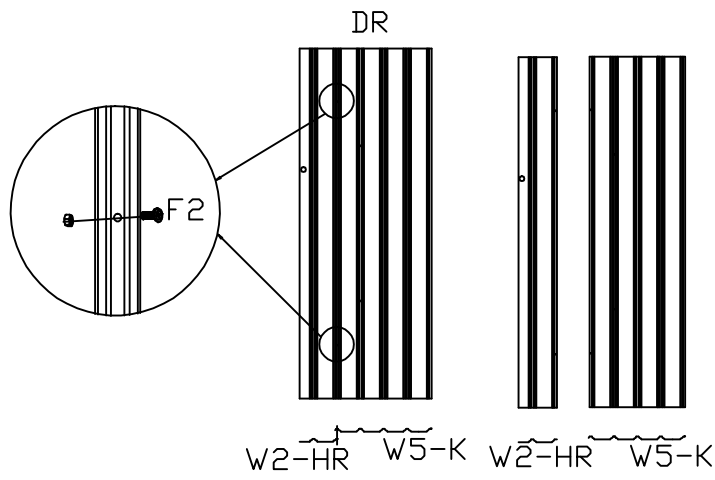

Right door panel splicing

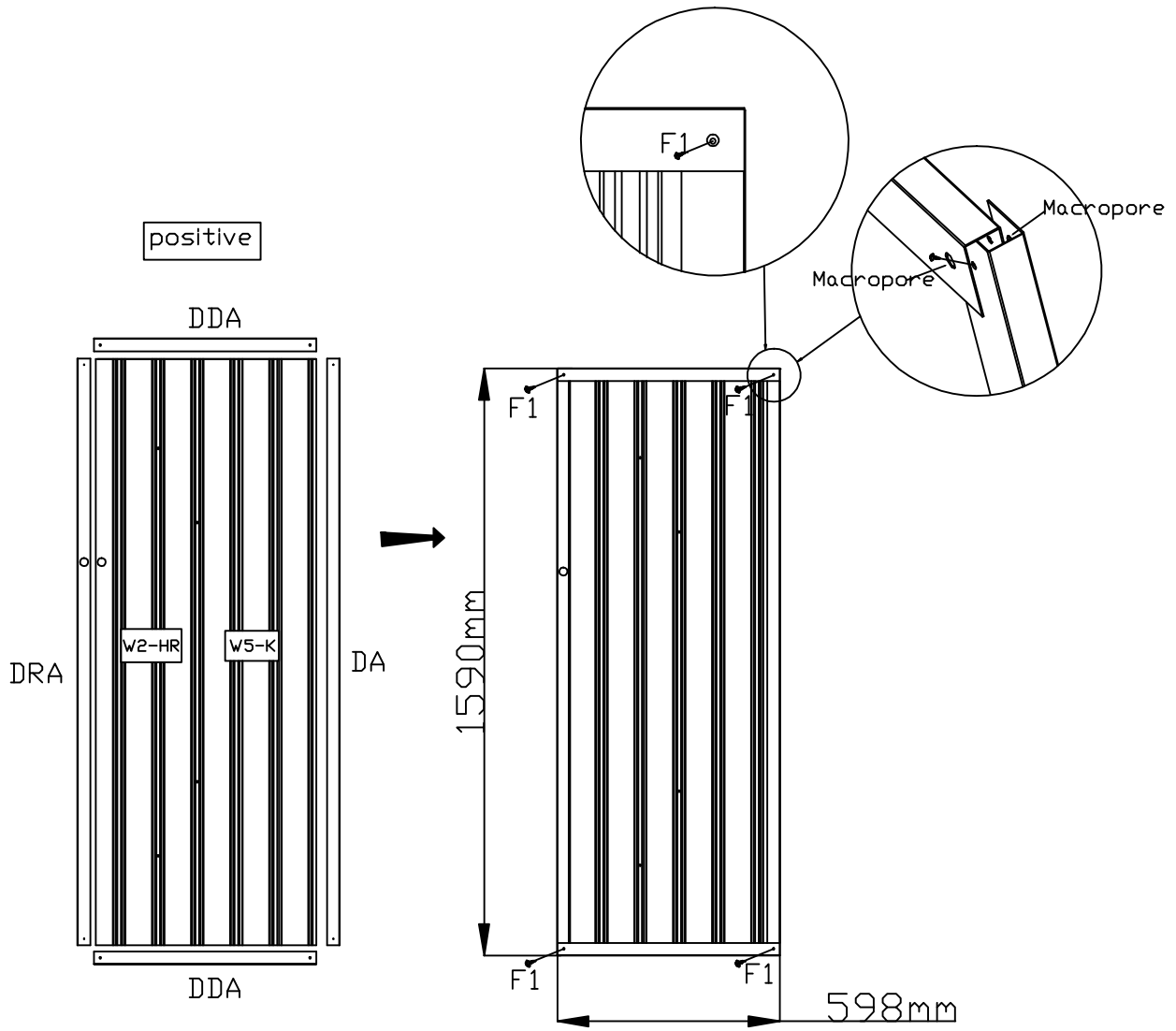

PART	NO.	QTY.
	W5-K	1
	W2-HR	1
	DA	1
	DRA	1
	DDA	2
	F1	4
	F2	2







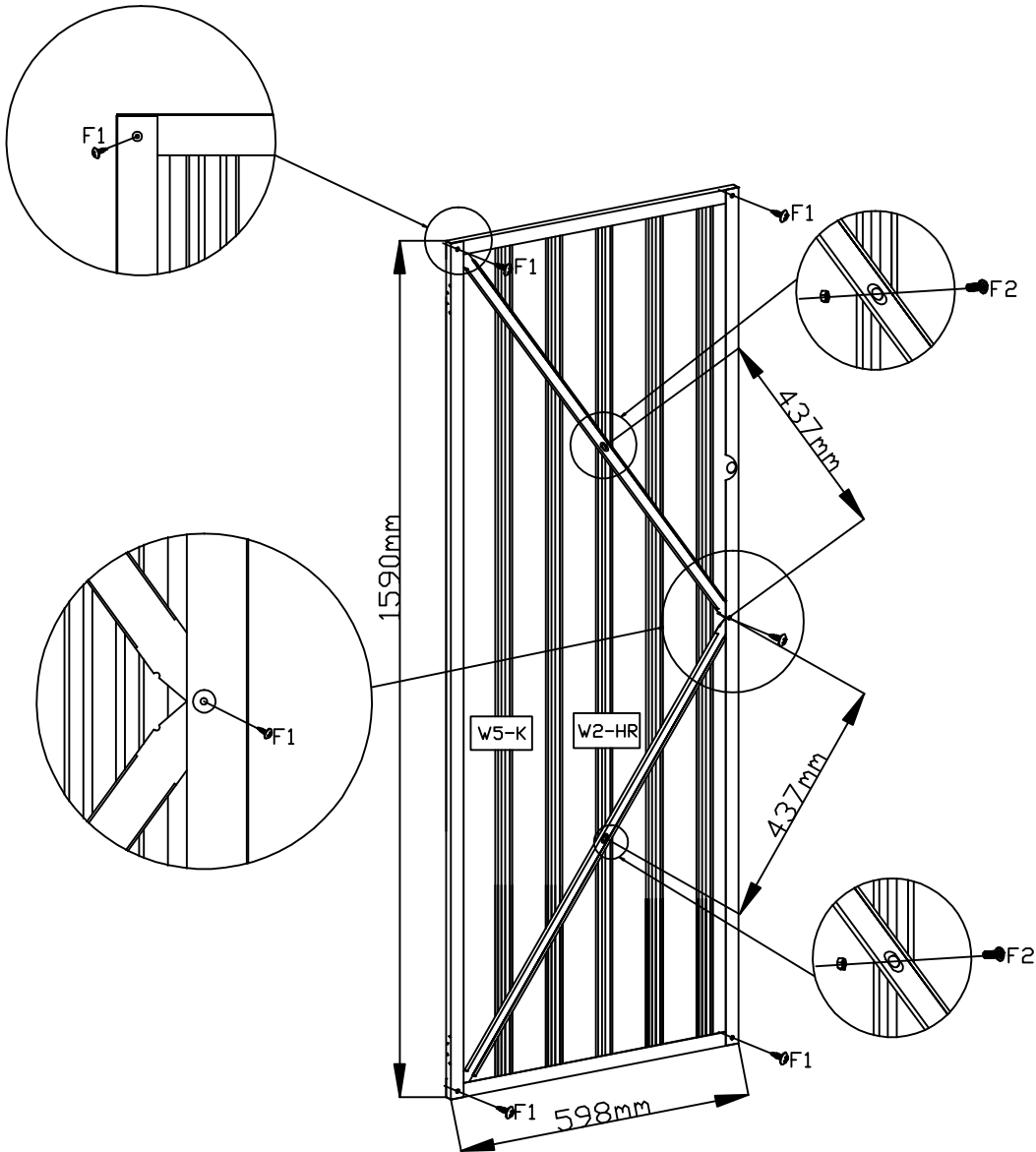

Right door panel splicing

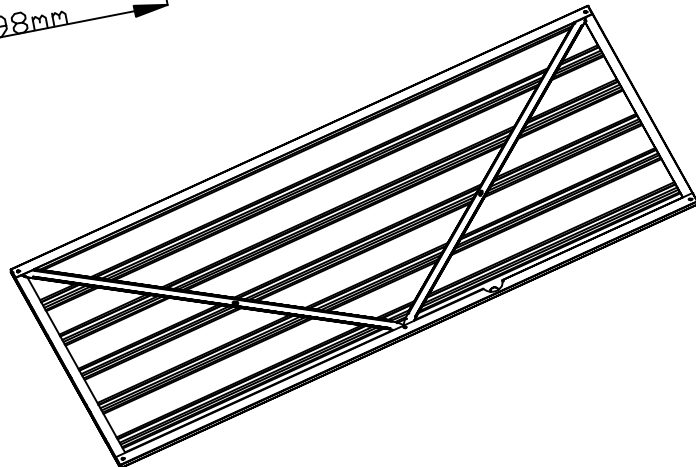
PART	NO.	QTY.
	DBA	2
	F1	5
	F2	2





The two ends of the DBA crossbar must be assembled inside the door frame

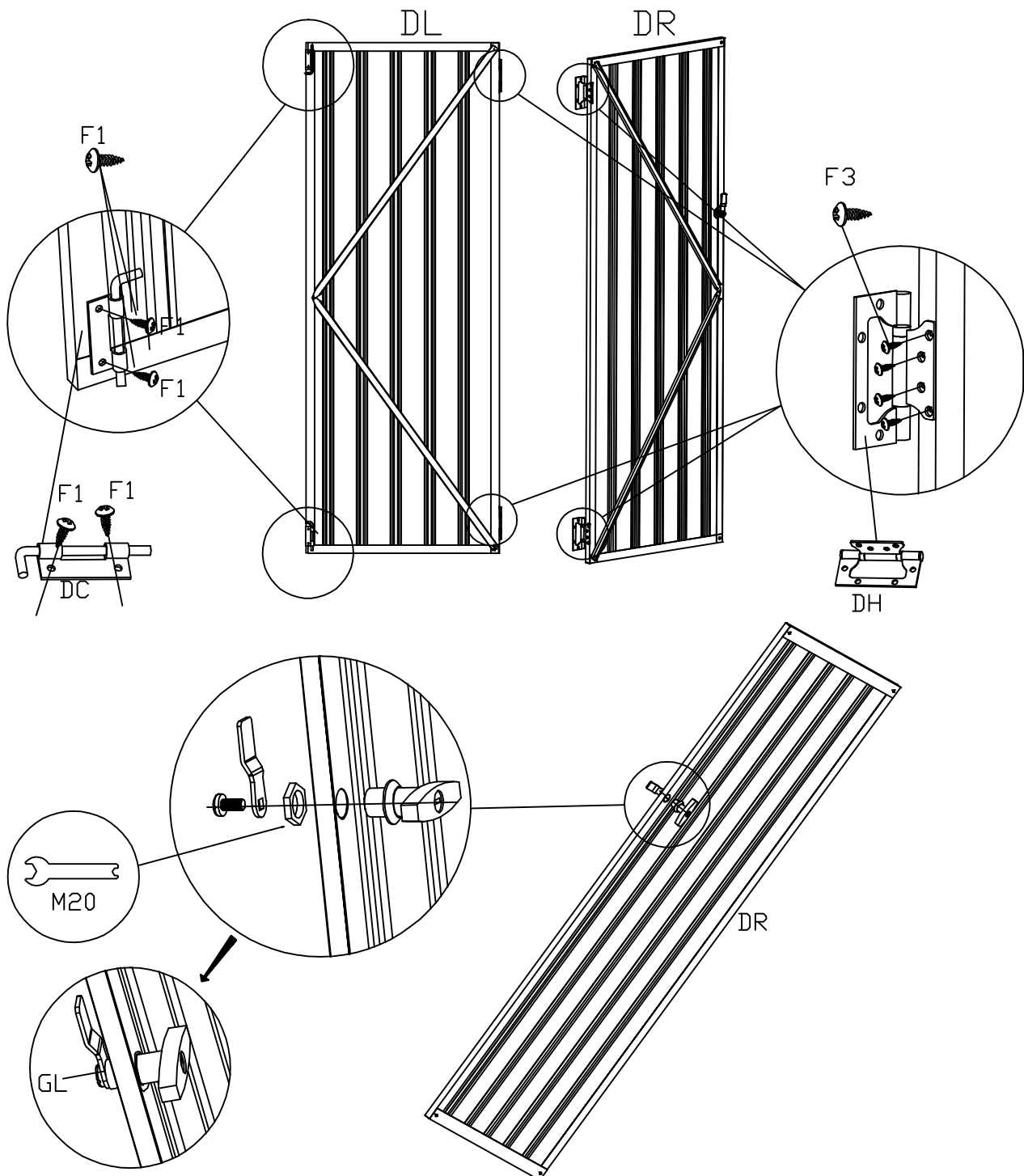

PART	NO.	QTY.
	DH	4
	DC	2
	F3	16
	GL	1
	F1	4



PART	NO.	QTY.
	DL	1
	DR	1
	F3	16

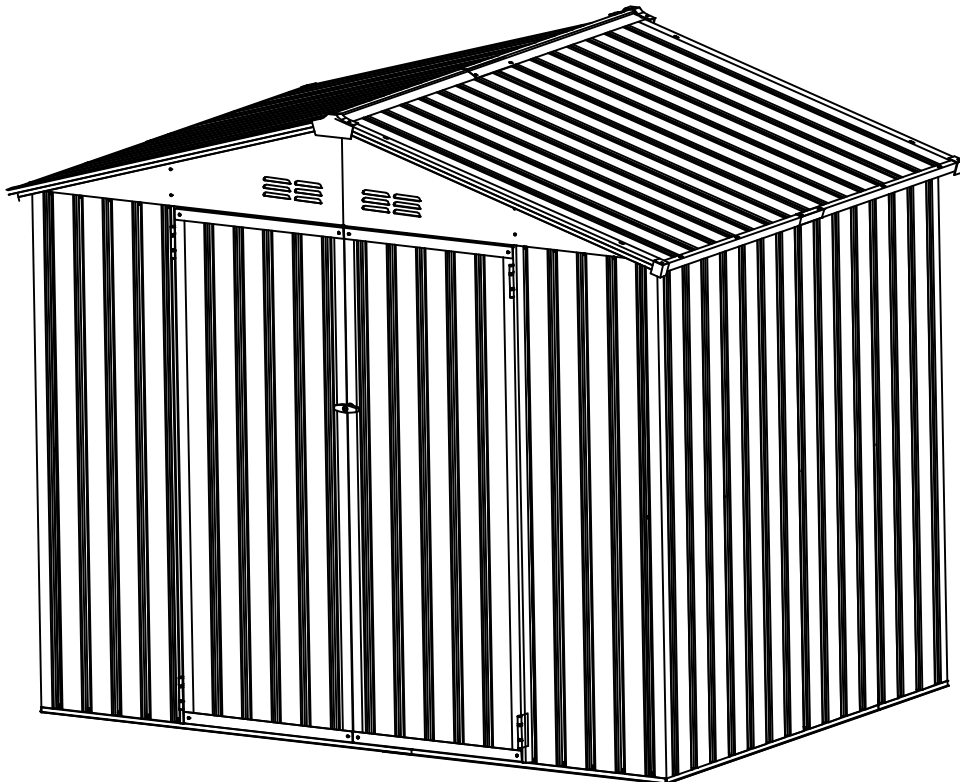
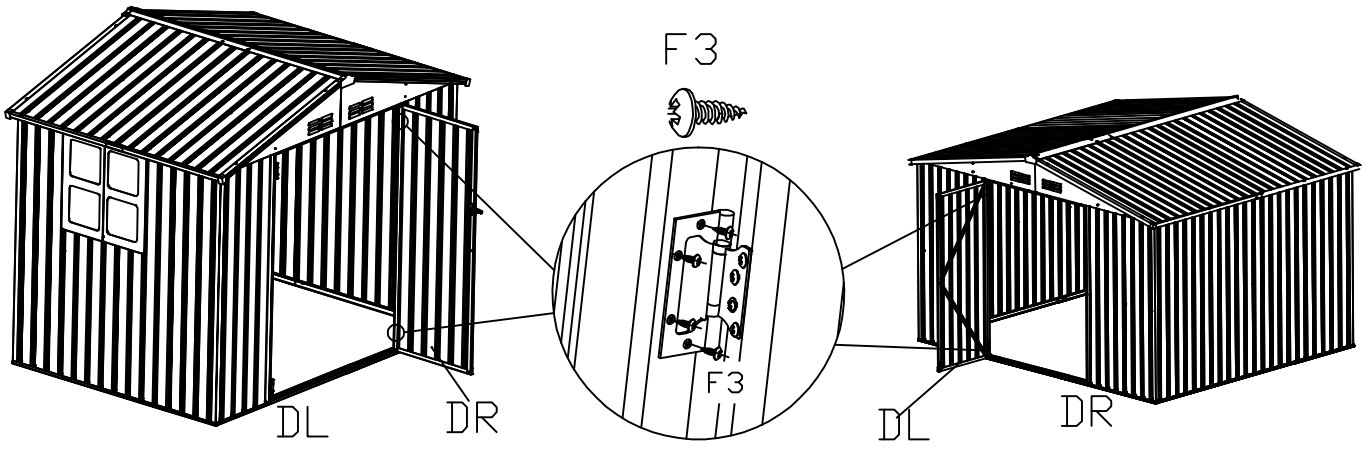

PART	NO.	QTY.
	SL	38

The exposed part of the assembly screw of the upper crossbeam support rod C4 needs to be covered with a plastic protective cap

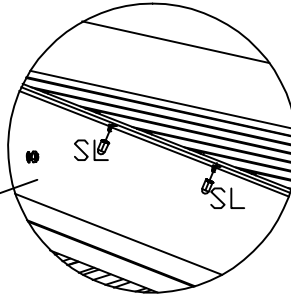
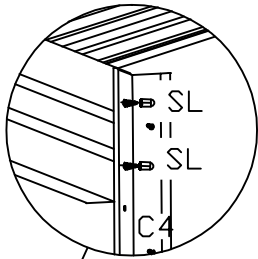

The exposed part of the screws for assembling the upper crossbeam K58-6 and the top cover needs to be covered with a plastic protective cap

