











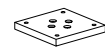
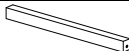

ASSEMBLY INSTRUCTIONS

Thank you for purchasing this quality product. Be sure to check all packing material care fully for small parts, which may have come loose inside the carton during shipment. Identify and count all parts and compare with the **HARDWARE LIST** below.

HARDWARE / PARTS LOCATION

Step 1 & 2 & 3 & 4 hardware > Inside red pack with red tape, placed at corner of top underside > Pedestal > Inside labeled carton, placed in the middle of top underside > Base > Inside labeled carton, placed in the middle of top underside > Stretcher > Inside labeled carton, place in the side of top underside > Support > Wrapped with 2ply corrugated carton, placed near corner of top underside

NO.	DESCRIPTION	SKETCH	QTY
A	Bench Top		1Pc
B	Pedestal		2Pcs
C	Base		2Pcs
D	Support		2Pcs
E	Stretcher		1Pc

NO.	HARDWARE LIST	QTY
1	 Bolt (Ø5/16"x90mm)	8Pcs
2	 Bolt (Ø5/16"x40mm)	16Pcs
3	 Spring Washer (Ø5/16x11x2mm)	24Pcs
4	 Flat Washer (Ø5/16"x19x2mm)	24Pcs
5	 Allen Wrench 4mm	1Pc
6	 Bolt (Ø5/16")	2Pcs
7	 Halfmoon Washer (Ø5/16")	2Pcs
8	 Hex Nut (Ø5/16")	2Pcs
9	 Wrench(Ø5/16")	1Pc

STEP 1

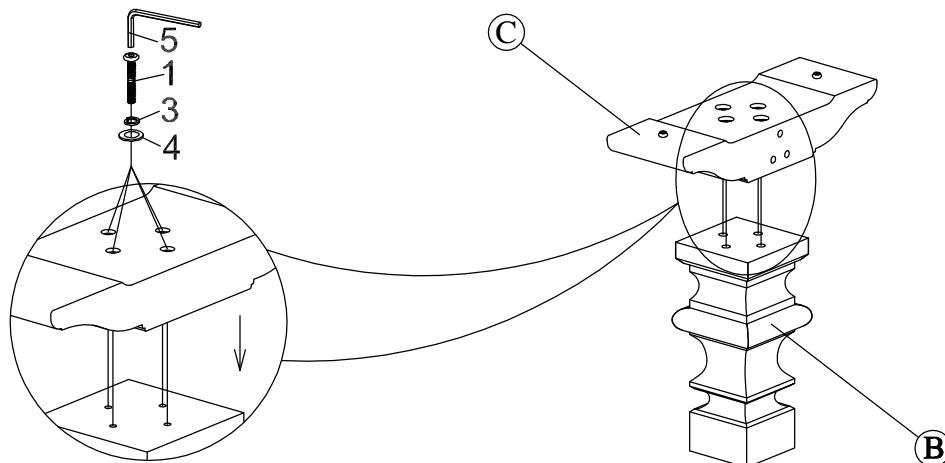

STEP 2

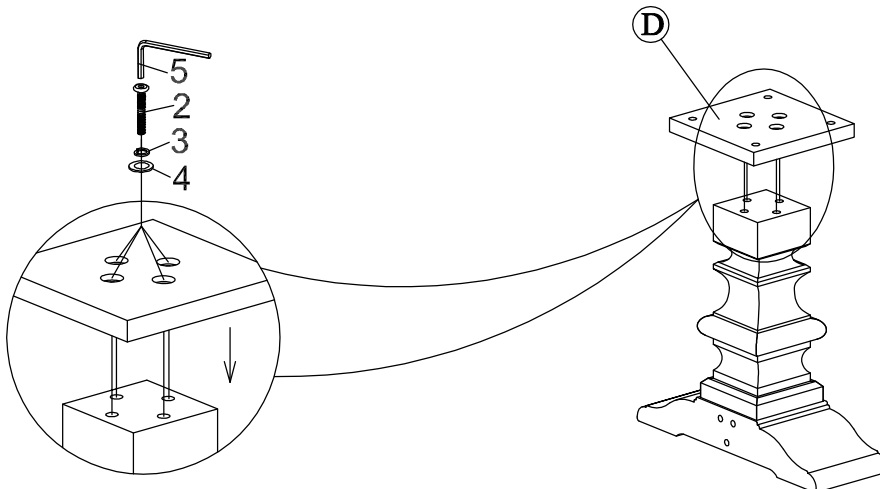

Note: Please **DO NOT** fully tighten all screws and bolts until the entire item is completely assembled

ASSEMBLY INSTRUCTIONS

Thank you for purchasing this quality product. Be sure to check all packing material care fully for small parts, which may have come loose inside the carton during shipment. Identify and count all parts and compare with the **HARDWARE LIST** below.

STEP 3

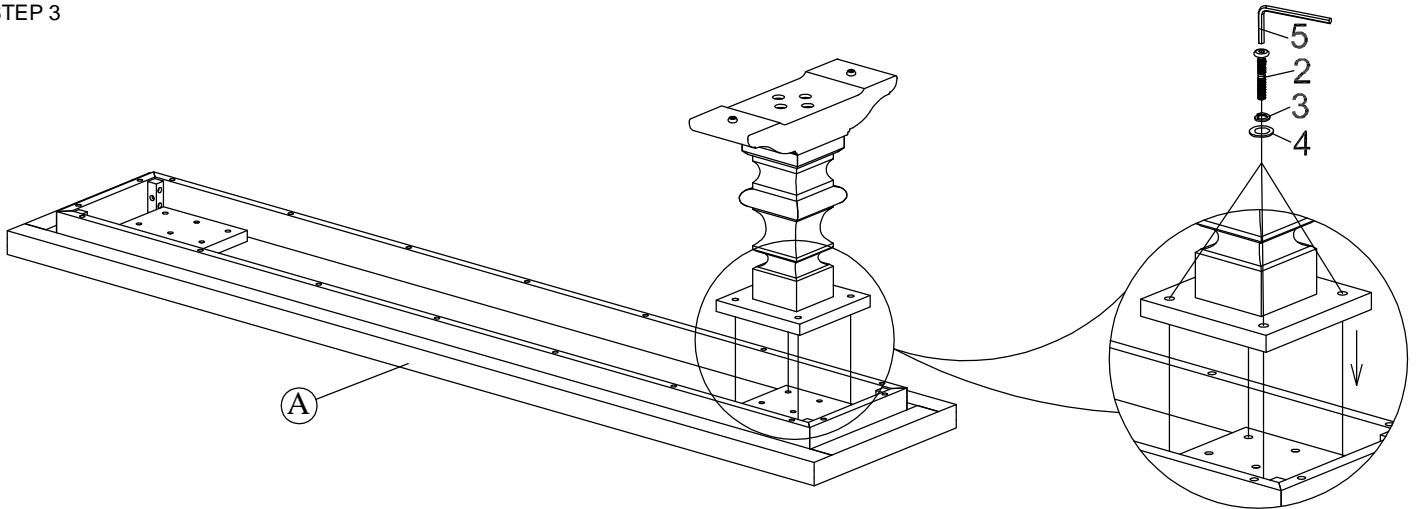

STEP 4

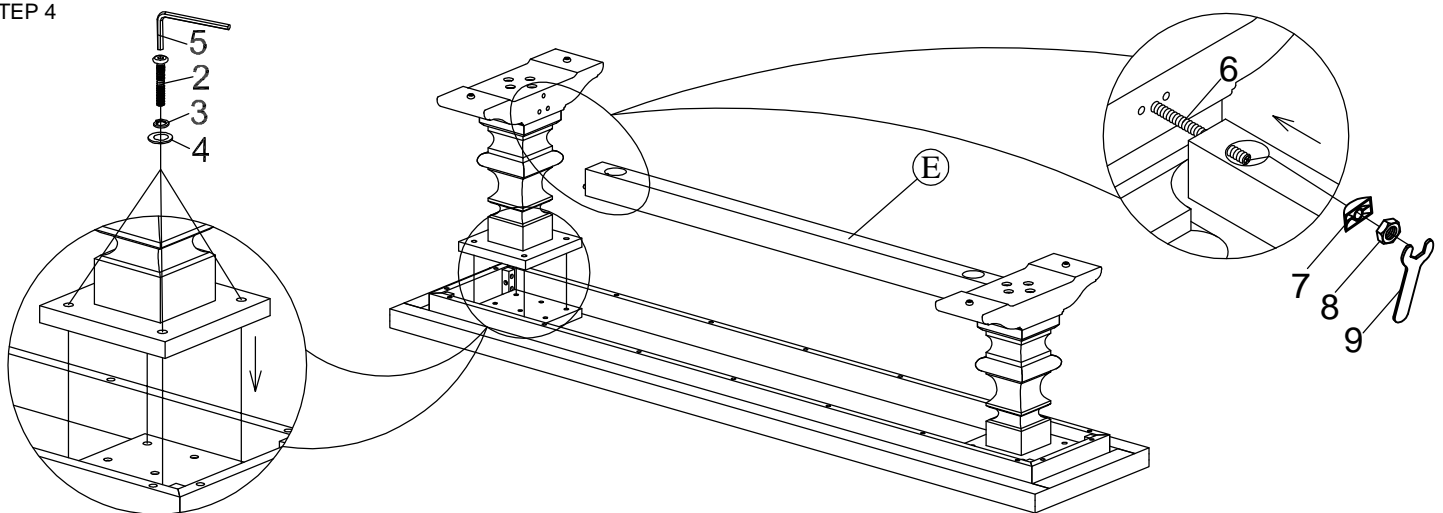

COMPLETED

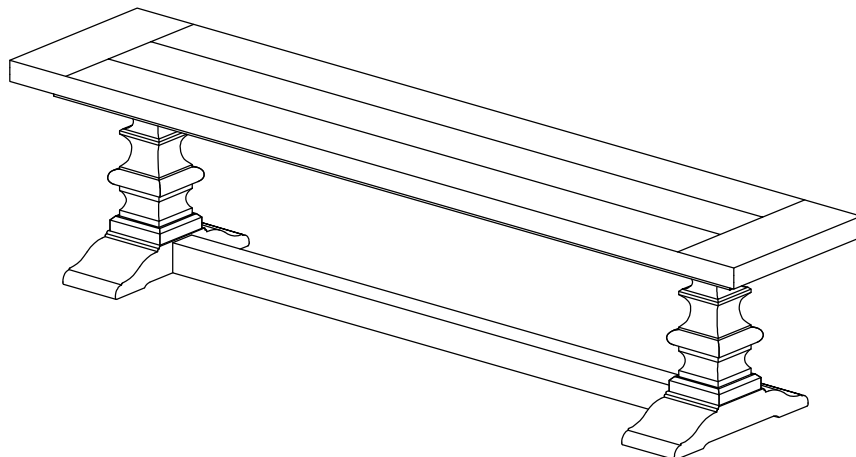

Note: Please **DO NOT** fully tighten all screws and bolts until the entire item is completely assembled