

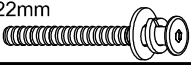



ASSEMBLY INSTRUCTIONS

MODEL : WM1779A-BT13

IMPORTANT NOTE :

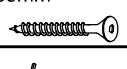
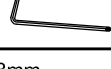
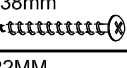
- * PLACE ALL WOODEN PARTS ON A CLEAN AND SMOOTH SURFACE SUCH AS A RUG OR CARPET TO AVOID THE PARTS FROM BEING SCRATCHED.
- * BEFORE YOU BEGIN, KINDLY FOLLOW THE ASSEMBLY INSTRUCTIONS STEP BY STEP.

HARDWARE LIST		
A	JCBB M8 x 80mm + S/W 5/16" + F/W 5/16" x 22mm 	8PCS
B	ALLEN KEY M5 	1PC
C	JCBC W BOLT M7 x 35mm 	1PC
D	ALLEN KEY M4 (BALL SHAPE) 	1PC
E	PH CB SCREW M4 x 38mm 	4PCS
F	PROTECTIVE DISC 22MM 	4PCS

PART LIST		
1	TABLE TOP	1PC
2	TABLE LEG	4PCS
3	X STRETCHER UP	1PC
4	X STRETCHER DOWN	1PC

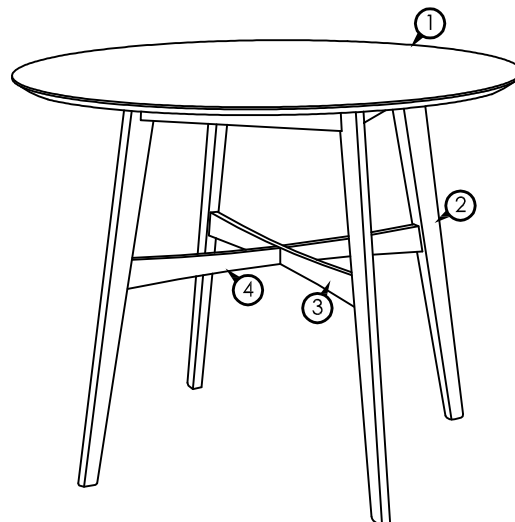

COMPLETED TABLE ASSEMBLY.

STEP 1

DO NOT FULLY TIGHTEN THE BOLT

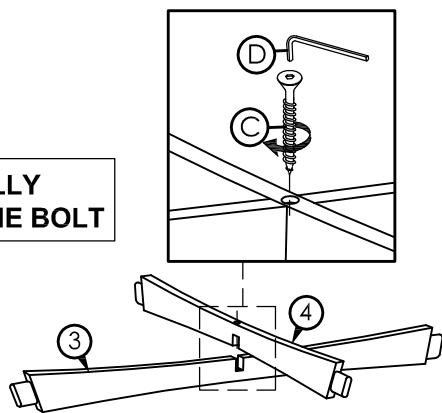

STEP 2

DO NOT FULLY TIGHTEN THE BOLT

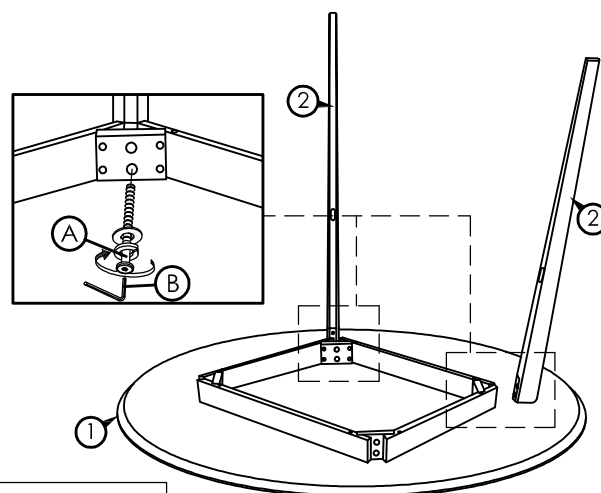

STEP 3

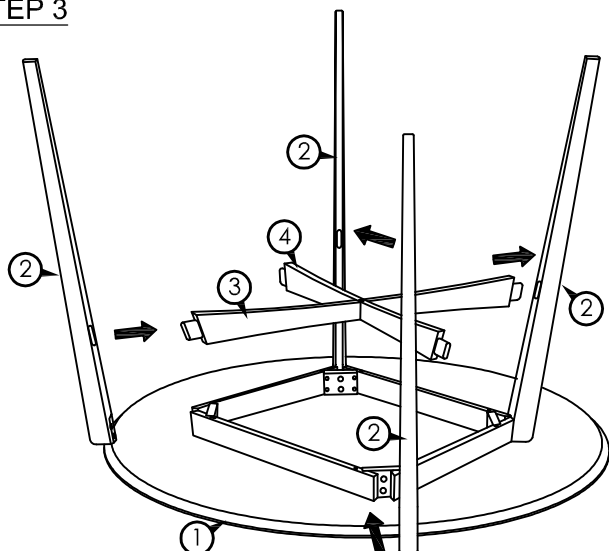

STEP 4

FULLY TIGHTEN ALL BOLTS & SCREWS

