

# ASSEMBLY INSTRUCTIONS

## MODEL : AE1938 DINING CHAIR

**IMPORTANT NOTE :**

- \* PLACE ALL WOODEN PARTS ON A CLEAN AND SMOOTH SURFACE SUCH AS A RUG OR CARPET TO AVOID THE PARTS FROM BEING SCRATCHED.
- \* BEFORE YOU BEGIN, KINDLY FOLLOW THE ASSEMBLY INSTRUCTIONS STEP BY STEP.
- \* DO NOT TIGHTEN ALL SCREWS UNTIL THE CHAIR IS FULLY SET-UP.

HARDWARE LIST			PART LIST		
A	JCBC M6 x 50mm + S/W M6 + F/W M6 x 13mm	4PCS	1	FRONT LEG FRAME	1PC
B	JCBC M6 x 30mm + S/W M6 + F/W M6 x 13mm	8PCS	2	BACK LEG FRAME	1PC
C	ALLEN KEY M4	1PC	3	SIDE STRETCHER (L/R)	2PCS
D	WOOD BUTTON Ø14.5mm	4PCS	4	CUSHION SEAT	1PC
			5	TOP REST	1PC

**CAUTIONS :**

- (1) DO NOT FULLY-TIGHTEN THE NUT OR NUT BOLTS INITIALLY UNTIL ALL NUTS OR BOLT IS READY ASSEMBLED.
- (TO AVOID CAUSING DAMAGES TO THE THREAD, DO NOT OVER-TIGHTEN THE NUTS OR BOLTS.)
- (2) KEEP ALL HARDWARE PART OUT OF REACH OF CHILDREN.

**STEP 1**

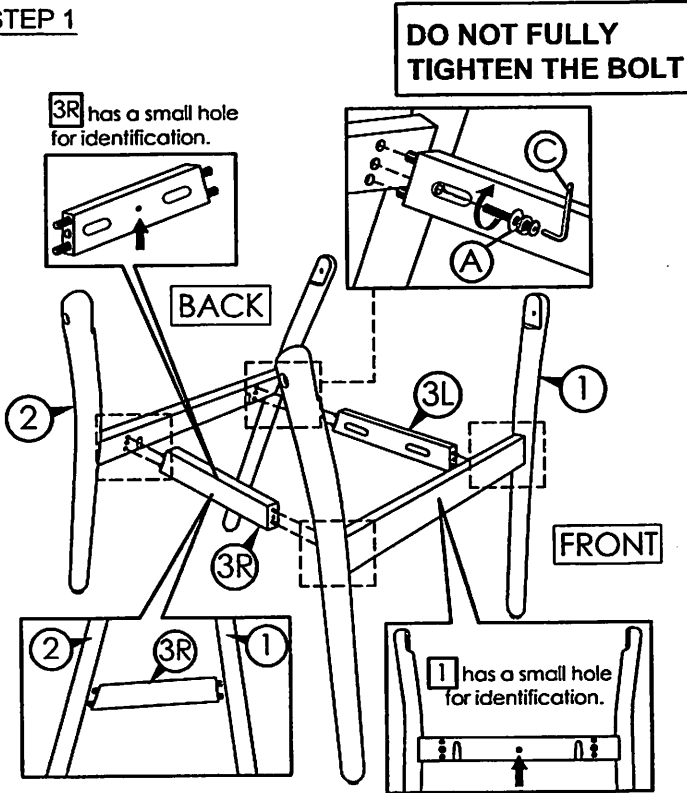

**STEP 2**

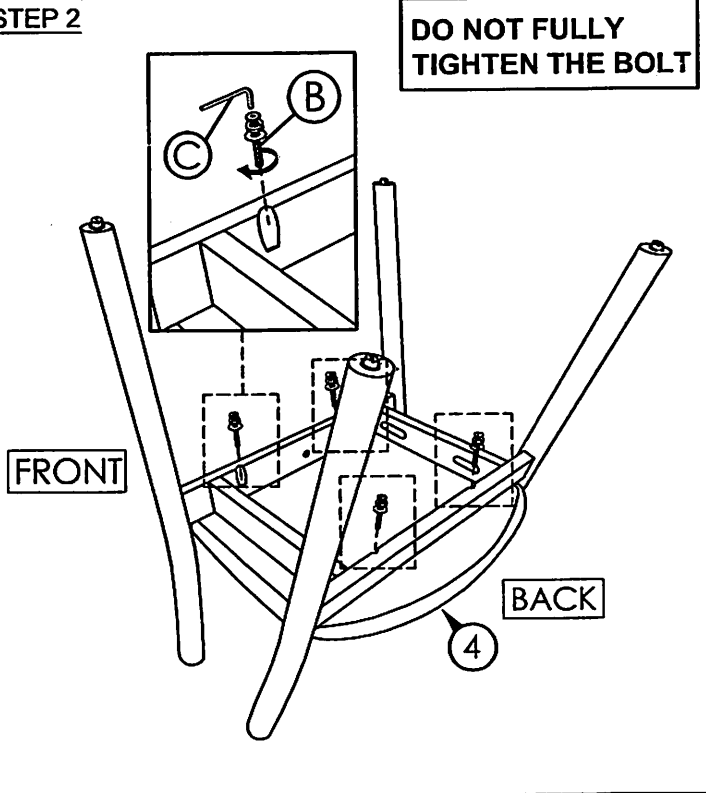

**STEP 3**

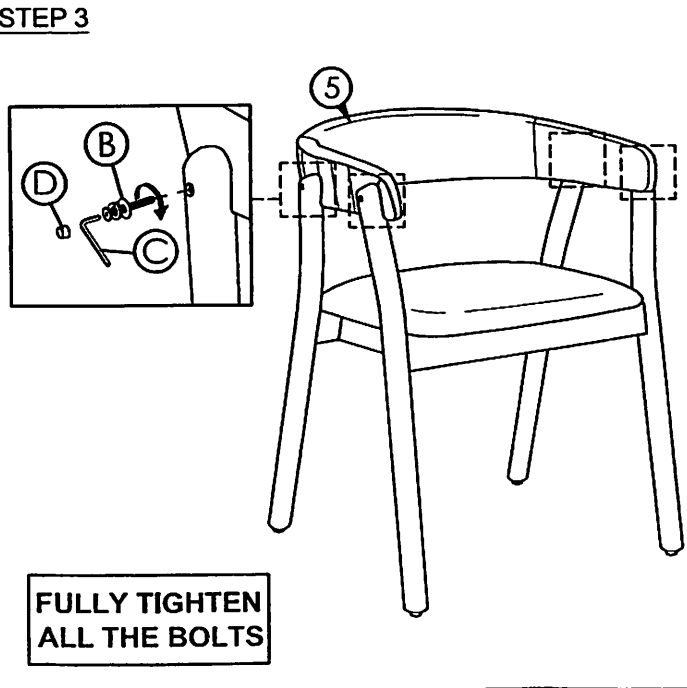

**STEP 4**

