

BISTRO BAR SWIVEL CHAIR

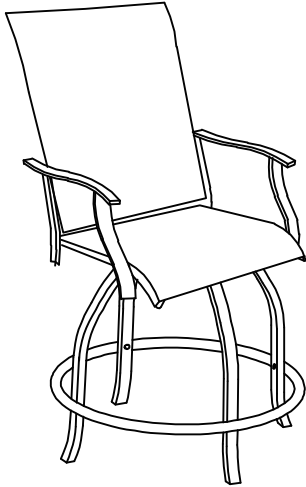





ASSEMBLY MANUAL





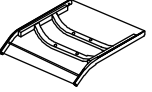
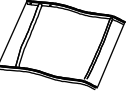

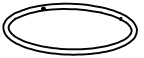

ASSEMBLY INSTRUCTIONS

- Prior to assembly, make sure you lay out and identify all the parts listed below in the parts list.
- Tighten all nuts and bolts securely. All bolts should be hand tightened before use. Never use power tools or excessive force during assembly and tightening of bolts.
- Should you experience any difficulty during assembly or if any part is missing or damaged:
Contact our customer service.

Part list

Part	Description	Qty
A	 Right Arm	1
B	 Left Arm	1
C	 Seat	1
D	 Back	1
E	 Leg	4
F	 Wheel	1
G	 Leg Connector	1
H	 M6*25 Bolt	4

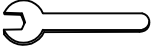
Part	Description	Qty
I	 M6*30 Bolt	16
J	 M6*35 Bolt	4
K	 Washer	36
L	 Nut	12
M	 Cap	20
N	 Nut	8
P	 Allen Key	1
Q	 Screw Driver	1

SWIVEL CHAIR

1. Connect Right Arm & Left Arm (Part A & Part B) to Seat (Part C) using Bolt (I), Washer (K) and Cap (M). As shown in diagram.

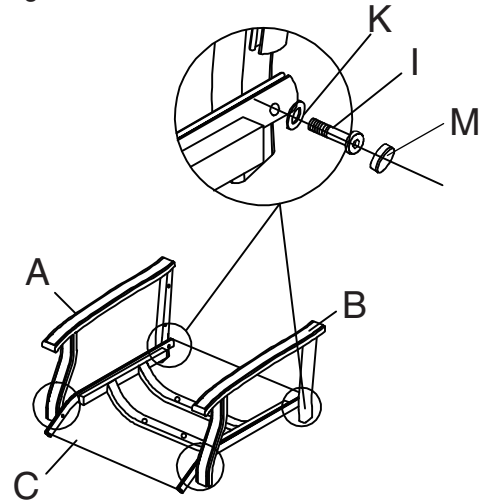

2. Connect Back (Part D) to Right arm (Part A) and Left arm (Part B) using Bolt (I), Washer (K) and Cap (M), as shown in diagram.

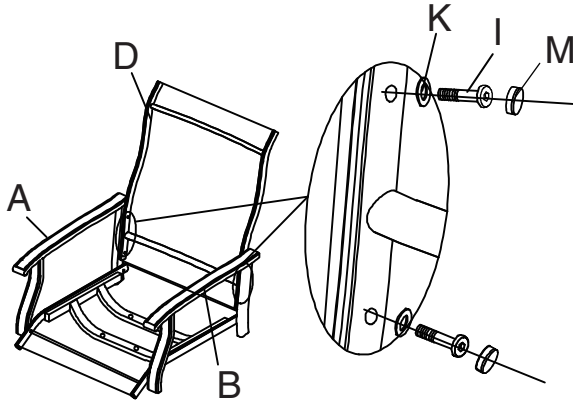

LOVESEAT

3. Attach Leg (Part E) to Wheel (Part F) using Bolt (I), Washer (K), Nut (L&N) and Cap(M) as shown in diagram.

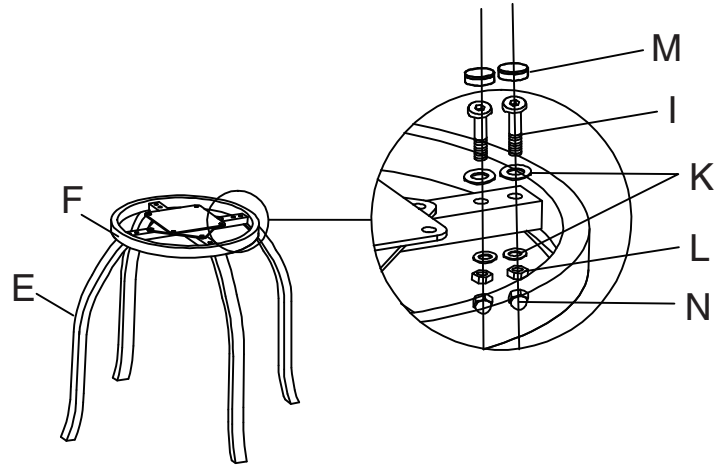

4. Attach Leg (Part E) and Leg Connector (Part G) using Bolt (J), Washer (K) and Cap (M) as shown in diagram.

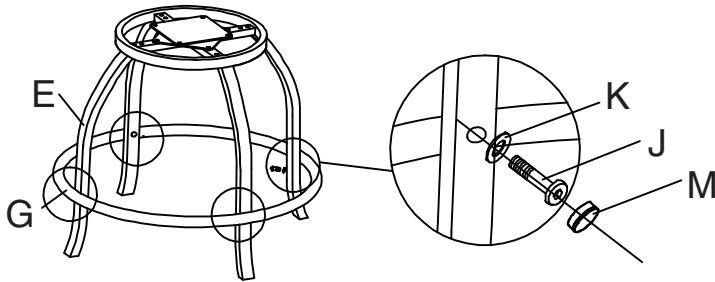

- 5.** ■ Connect the finished ase (PartE&F&G) to the seat (Part C) using Bolt(H),Washer(K) and Nut(L).As shown in diagram.

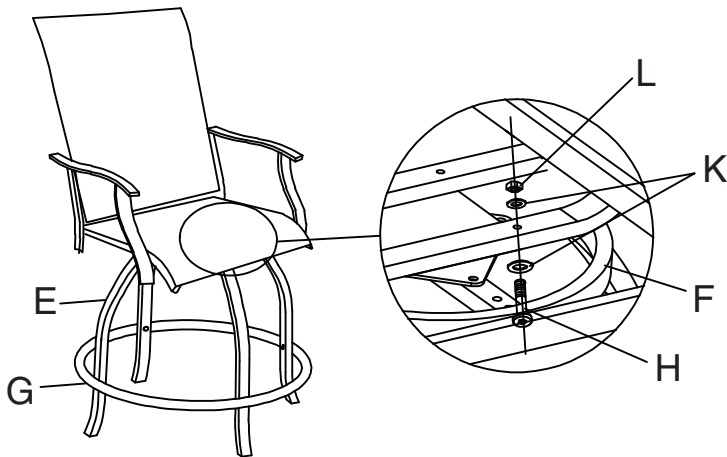

- 6.** ■ Eventually,Make sure all bolt are fixed tightly before using on the level ground.