

Assembly Instructions

Caution: You must read this before you proceed

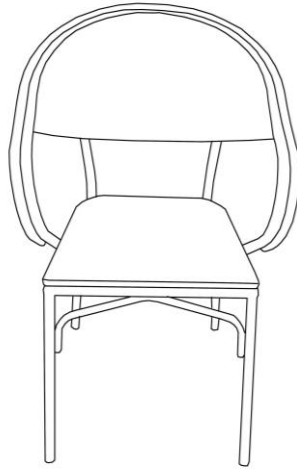

Chair



Part List

Label	Picture	Description	QTY
A	A line drawing of the backrest component, showing a curved backrest with a horizontal support bar and two vertical supports that connect to the back legs.	Backrest with Back Leg	1
B	A line drawing of the seat top component, showing a rectangular seat top with a front leg and a rear leg.	Seat Top with Front Leg	1

Hardware

Label	Picture	Description	QTY
①		Bolt (M6*15mm)	5
②		Allen Key(M6)	1

Assembly Preparation

Before Beginning Assembly:

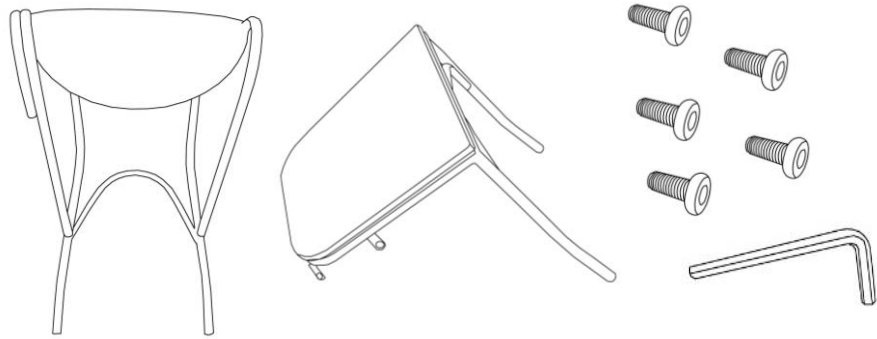

- Read instructions, cover to cover-



- Have 2 adults on hand for assembly-



- Do not assemble on flooring or carpet-



- Assemble on a clean non-marring surface (packing foam)-



- Save all packaging until finished-

Assembly Steps

Overview

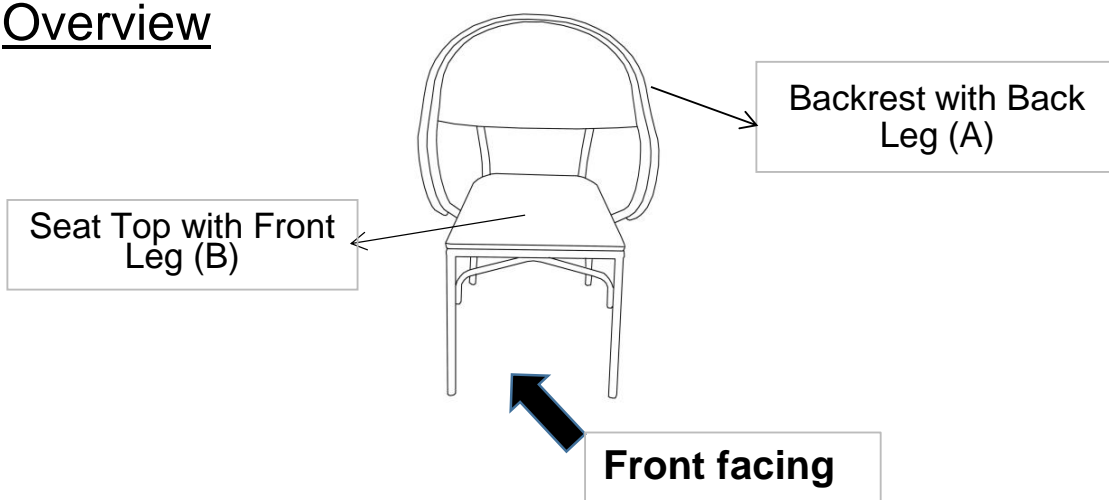

This Chair has multiple parts and may require up to 15 minutes to assemble. To give you an overview of the Chair parts, the above picture is to help you put the various parts into perspective. Please read through the instructions below to familiarise yourself with the parts and steps before assembly.

Step 1

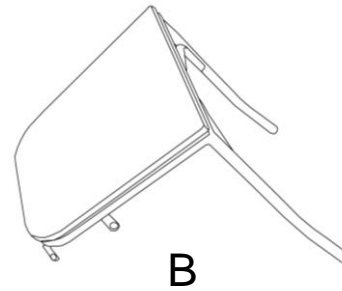
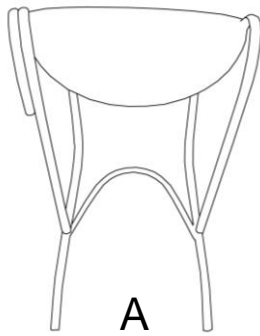

Unpack and place all parts on a clean, non-marring surface.

Step 2

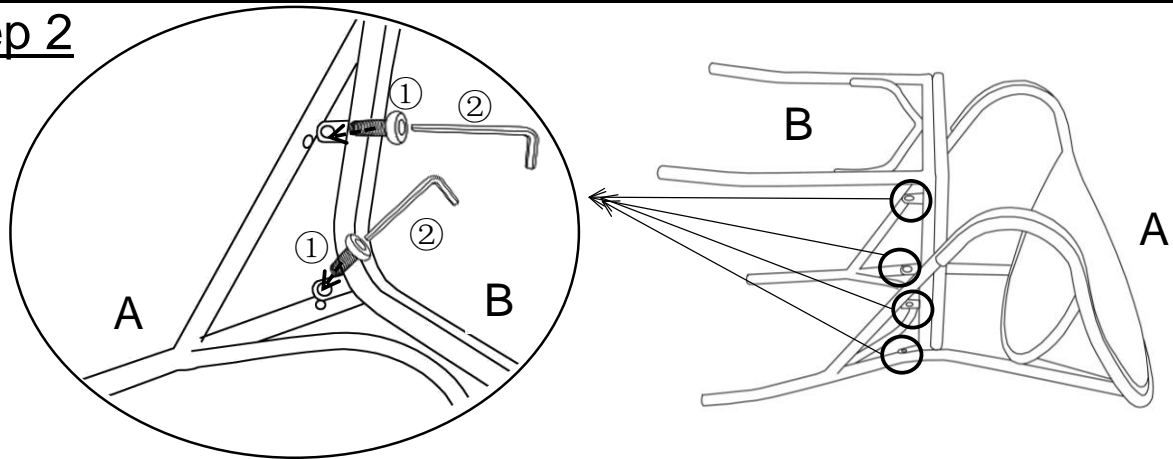

Lay the Backrest with Back Leg(A) facedown onto a clean, non-marring surface. Attach the Seat Top with Front Leg(B) to Backrest with Back Leg(A) using Bolts(①) with Allen Key(②).

Tighten the Bolts fully in a sequential manner.

Step 3

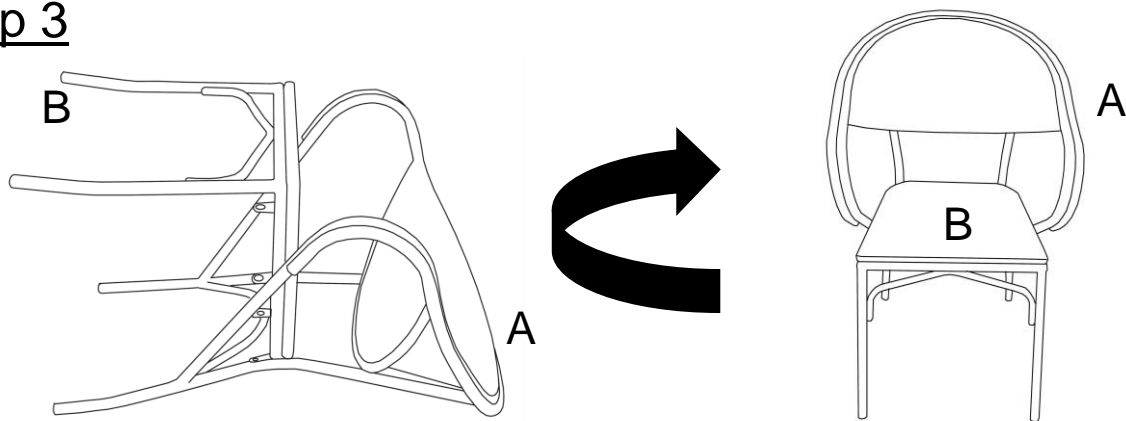

Stand the Chair up.



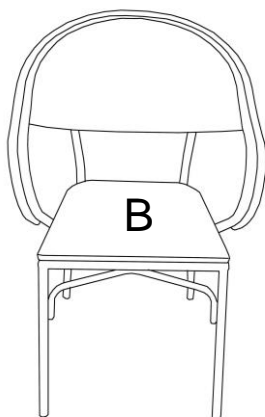





Step 4



Your Chair is ready for use.

This Chair can only be used on a flat, level surface.

Care & Maintenance

-  Do not put hot items directly on furniture surface
 -  Do not clean furniture with harsh cleansers or polish.
 -  To obtain the longest lifespan of your outdoor products, minimizing exposure to direct sunlight is recommended.
 -  Children should not climb or jump on the furniture.
 -  Do not write on furniture without a padded barrier to protect the surface.
 -  To obtain the longest lifespan of your outdoor products, avoid extended and lengthy exposure to rain, snow, and direct sunshine. Whenever possible cover the product and /or place under patio or awnings.
 -  Not for commercial use. For residential use only .
 -  Stains may be removed with mild soap solution and damp cloth.
-
-  Dust and pick-up spills using a clean, non-colored, lint-free cloth .



Assembly Instructions

Caution: You must read this before you proceed

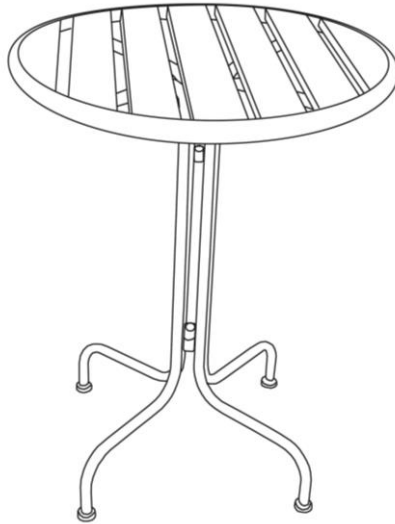

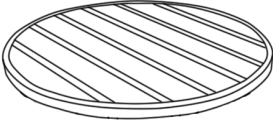
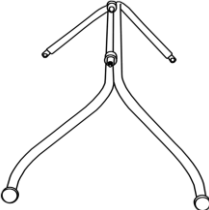

Table



Part List

Label	Picture	Description	QTY
C		Table Top	1
D		Table Leg-Left Part	1
E		Table Leg-Right Part	1

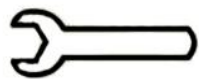
Hardware

Label	Picture	Description	QTY
①		Bolt (M6*15mm)	5
②		Allen Key (M6)	1
③		Nut (M8)	2
④		Spanner (M8)	1
⑤		Washer (M6)	2

Assembly Preparation

Before Beginning Assembly:

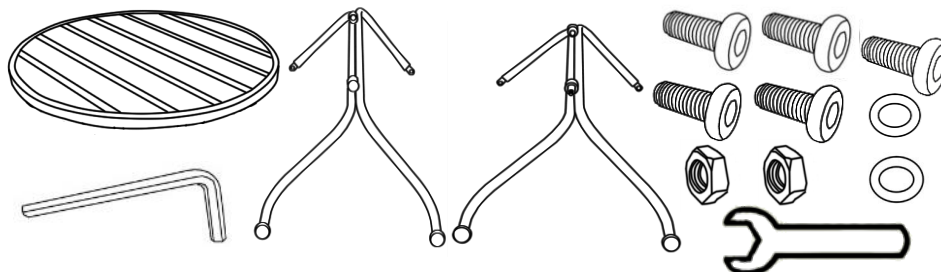

- Read instructions, cover to cover-



- Have 2 adults on hand for assembly-



- Do not assemble on flooring or carpet-



- Assemble on a clean non-marring surface (packing foam)-



- Save all packaging until finished-

Assembly Steps

Overview

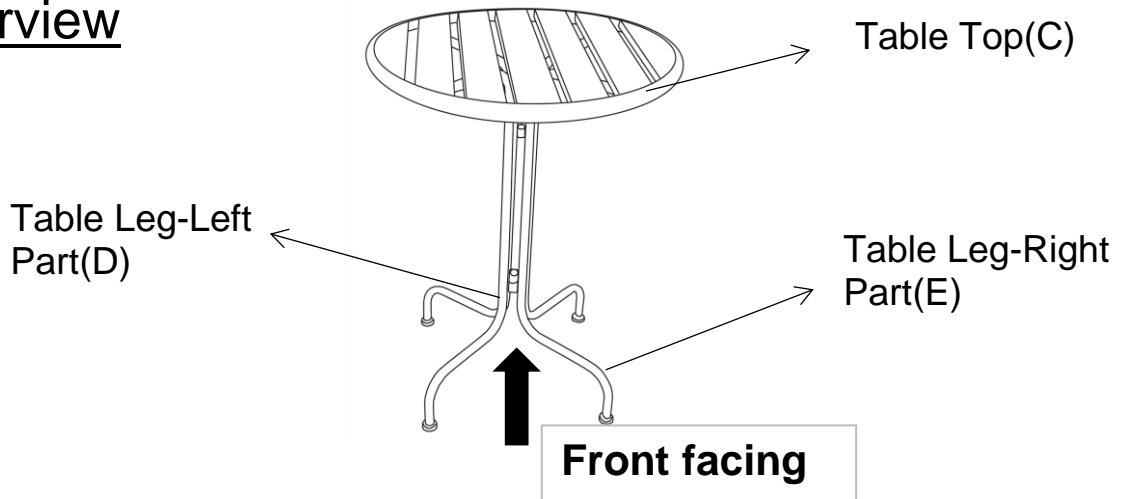

This Table has multiple parts and may require up to 20 minutes to assemble. To give you an overview of the Table parts, the above picture is to help you put the various parts into perspective. Please read through the instructions below to familiarise yourself with the parts and steps before assembly.

Step 1

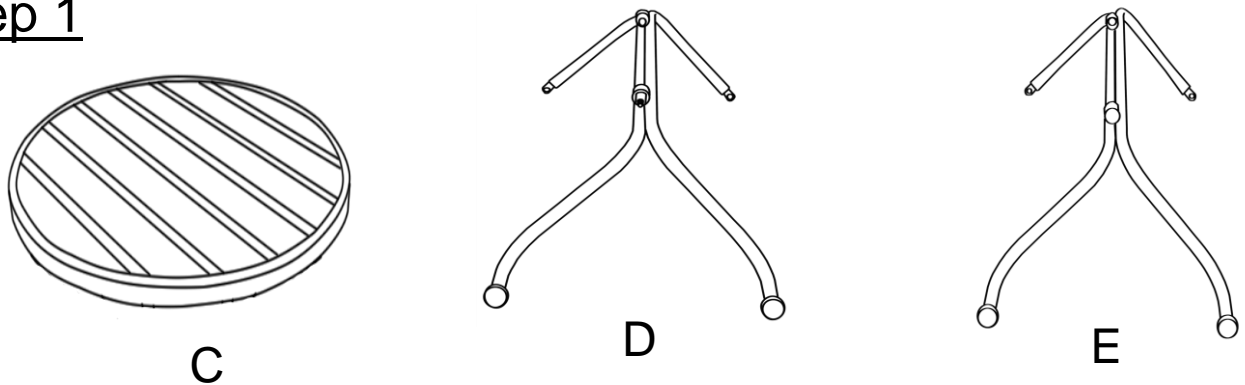

Unpack and place all parts on a clean, non-marring surface.

Step 2

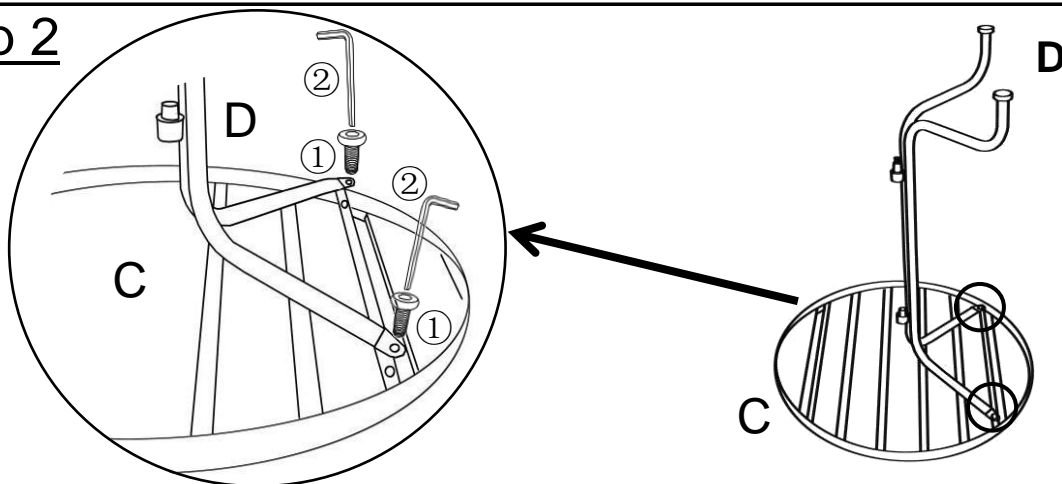

Lay the Table Top(C) facedown onto a clean, non-marring surface.
Attach the Table Leg-Left Part(D) to Table Top(C) using Bolts(①) with Allen Key(②).

Do not fully tighten the Bolts.

Step 3

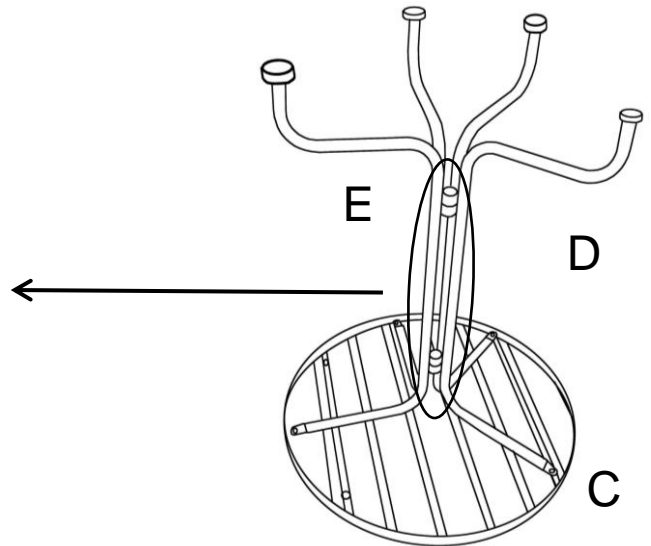
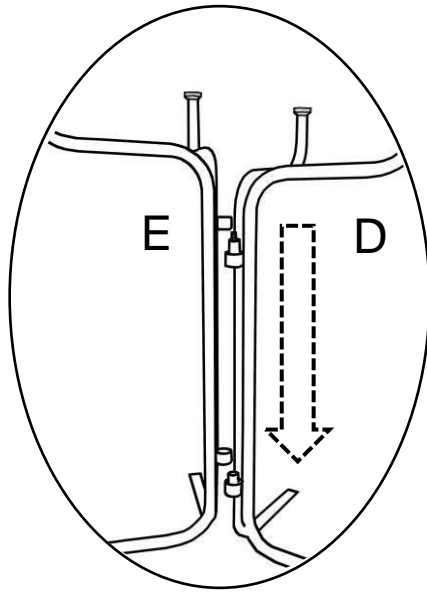

Insert the Table Leg-Right Part(E) into Table Leg-Left Part(D).

Step 4

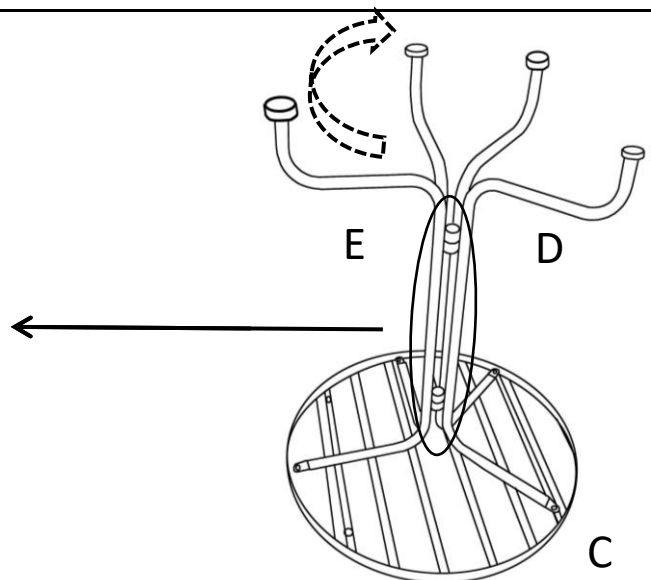
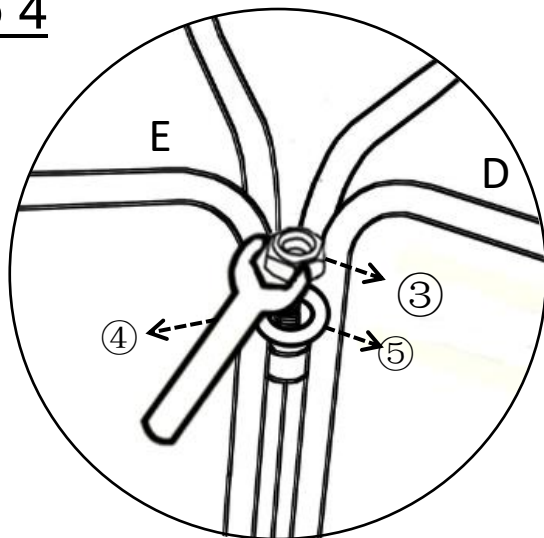

Attach the Table Leg-Right Part(E) to Table Leg-Left Part(D) using Washer(⑤) and Nuts(③) with Spanner(④). Keep Table Leg-Right part(E) toward to the side of Table Leg-Left Part(D).

Tighten the nuts.

Step 5

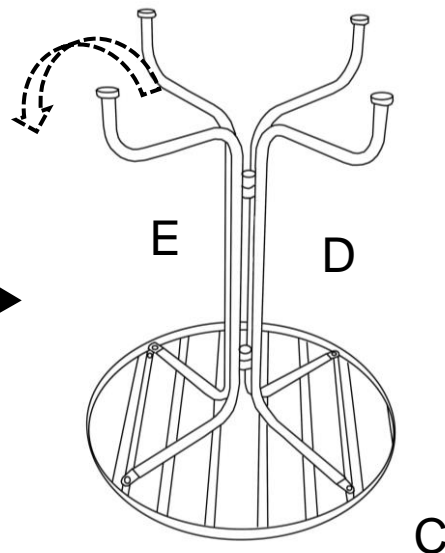
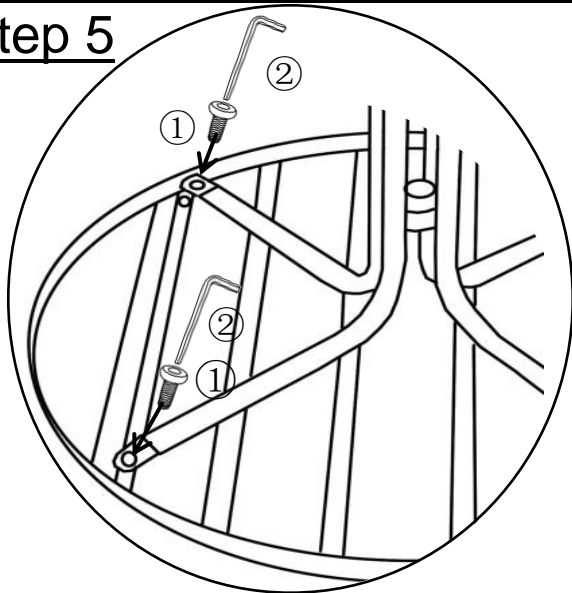

Rotate the Table Leg-Right Part(E) to the required position on Table Top(C) as shown.

Attach Table Leg-Right Part(E) to Table Top(C) using Bolts(1) with Allen Key(2)

Do not fully tighten the Bolts

Step 6

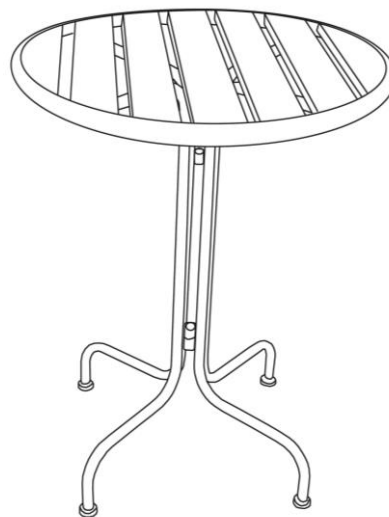
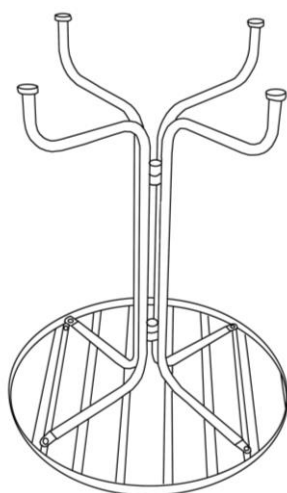

Stand the Table up.

Step 7

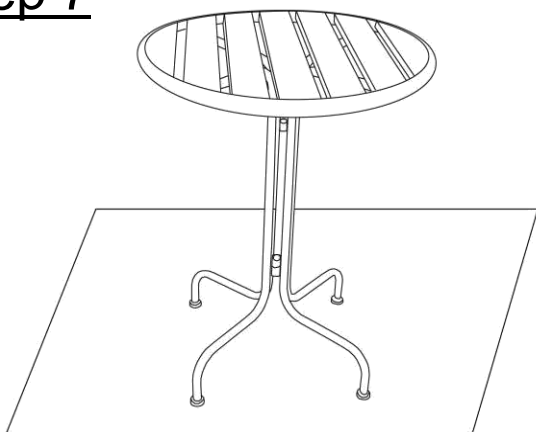

If wobble



Test again

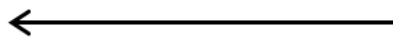

30CM~50CM

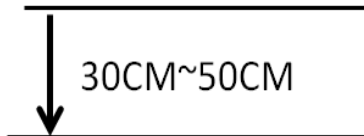





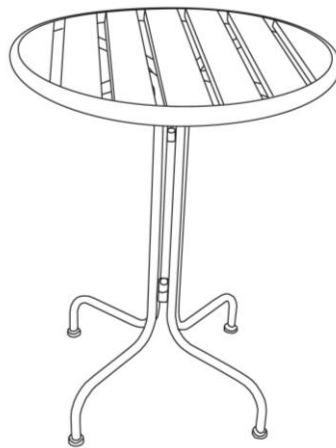













Place the Table on a LEVEL SURFACE to see if it wobbles.
 If it wobbles, lift the Table to some 30cm to 50cm high from the ground.
 Keep your feet and toes well away from the drop zone.
 Drop the Table freely and vertically with the four legs, hitting the ground, at the same time.
 This Drop Test will help to ensure that all the bolts and gaps to all reach full alignment status.
 Test again for evenness on a LEVEL SURFACE.
 If no wobbles found, lay down the Table and proceed to tighten all the Bolts.
When tightening these Bolts, tighten sequentially.
DO NOT tighten any Bolt fully and then move on towards the next one.
If there is still wobbles, loosen the Bolts and execute this same drop tests.

Step 8



Your Table is ready for use.
This Table can only be used on a flat, level surface.

Care & Maintenance

-   ● Do not put hot items directly on furniture surface
 -   ● Do not clean furniture with harsh cleansers or polish.
 -   ● To obtain the longest lifespan of your outdoor products, minimizing exposure to direct sunlight is recommended.
 -   ● Children should not climb or jump on the furniture.
 -   ● Do not write on furniture without a padded barrier to protect the surface.
 -   ● To obtain the longest lifespan of your outdoor products, avoid extended and lengthy exposure to rain, snow, and direct sunshine. Whenever possible cover the product and /or place under patio or awnings.
 -   ● Not for commercial use. For residential use only .
 -   ● Stains may be removed with mild soap solution and damp cloth.
-
-   ● Dust and pick-up spills using a clean, non-colored, lint-free cloth .