

ASSEMBLY INSTRUCTION



This instruction booklet contains important safety information. please read and keep for future reference.

This sofa collection can works as modular sofa function, you can buy different section of the sofa such as armrest sets, armless middle seat, and ottoman to build it as 2 seater sofa, 3 seater sofa, 4 seater sofa, L shape sectional sofa, U shape sofa and sofa sets.

Measure your living room size before you make a decision to buy more components to ensure all sofa section are well fit your living room area.

To ensure safe and satisfactory use of this product, please carefully read the below instructions before hand.

- 1.This sofa ships in several boxes,we recommend unpacking and starting assembly when several boxes are received.
- 2.Our cushions are vacuum packed for convenient shipping. Please allow 2-3 days for them to fully expand to their original shape and for any wrinkles to disappear.
- 3.In the event that a part is damaged or missing, no need to return the product, we will gladly help and ship your replacement parts free of charge.



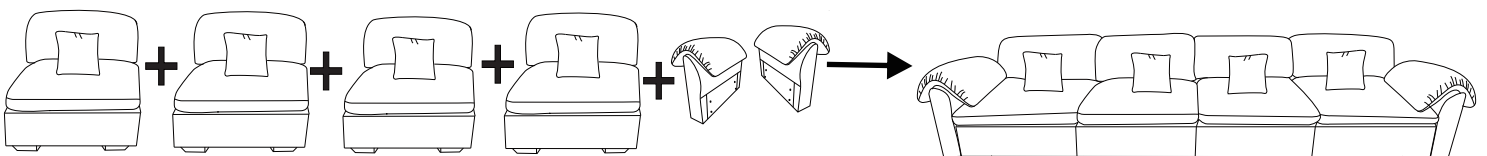
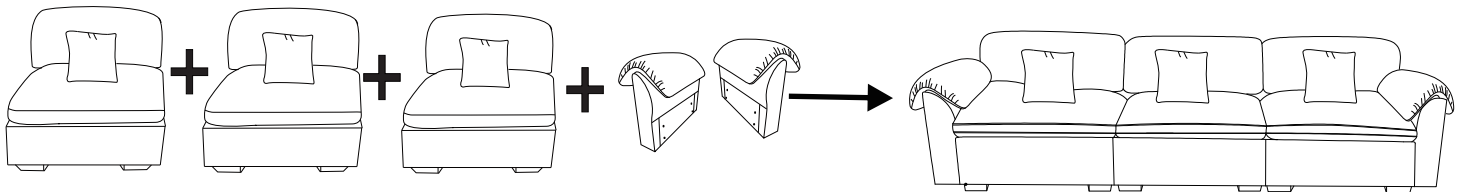
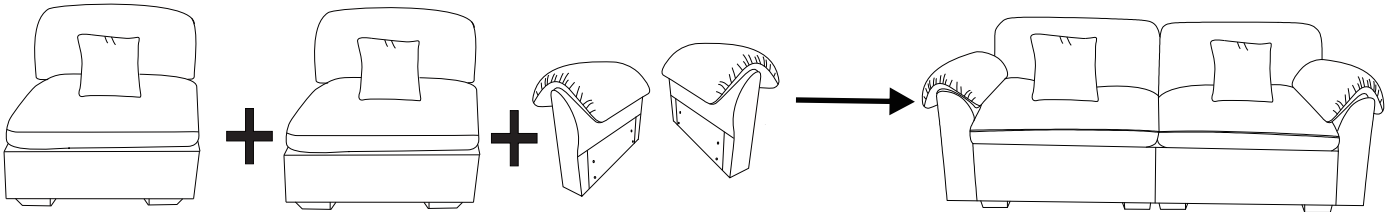
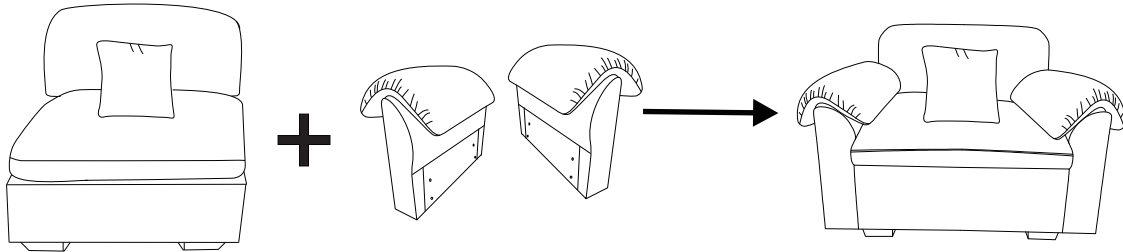





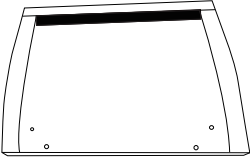
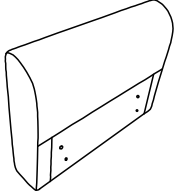
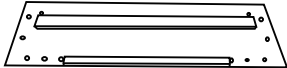
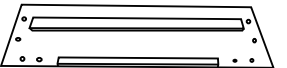

Below are some guidelines for you how you can do mix and match.

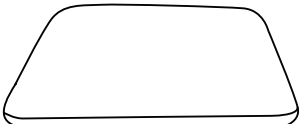

Assembly Instructions

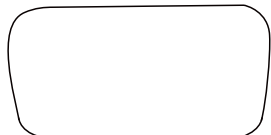
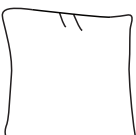
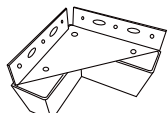
IF YOU BUY A SINGLE SOFA
please follow below assembly instruction

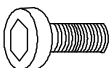
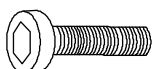
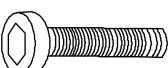
Parts List

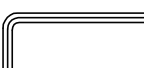
<p>A</p>  <p>Backrest*1</p>	<p>B</p>  <p>Armrest*2</p>	<p>C</p>  <p>Back panel*1</p>	<p>D</p>  <p>Front panel*1</p>	
<p>E</p>  <p>Left panel*1</p>	<p>F</p>  <p>Right panel*1</p>	<p>G</p>  <p>Upper cover plate*1</p>	<p>H</p>  <p>Bottom plate*1</p>	
<p>I</p>  <p>Seat cushion*1</p>	<p>J</p>  <p>Armrest pillow*2</p>	<p>K</p>  <p>Small back cushion*1</p>	<p>L</p>  <p>Big back cushion*1</p>	
<p>M</p>  <p>Pillow*1</p>	<p>N</p>  <p>Leg*4</p>	<p>O</p>  <p>Leg*2</p>	<p>P</p>  <p>Bolt*24 M8*18mm</p>	<p>Q</p>  <p>Bolt*4 M8*30mm</p>
<p>R</p>  <p>Bolt*8 M8*50mm</p>	<p>S</p>  <p>Washer*12</p>	<p>T</p>  <p>Plastic gasket*2</p>	<p>U</p>  <p>Allen Key*1</p>	

Note: Please retain all boxes until you are certain that your product isn't damaged and that you do not wish to return it. Disposal of boxes may prevent our ability to resolve your request.

STEP 1

- ① Assemble the Back panel (C) with bolts (P).

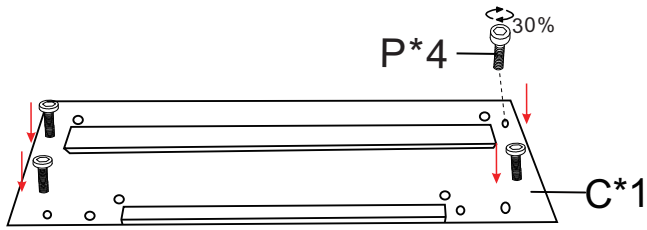

Screw tightening 30%

- ② Assemble the Front panel (D) with bolts (P).

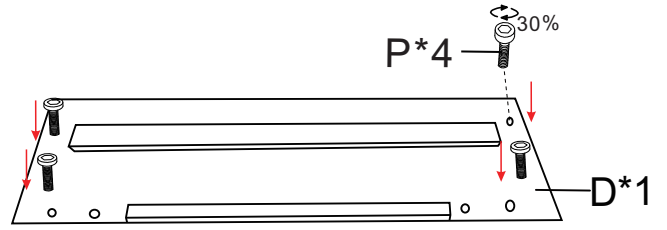

Screw tightening 30%

- ③ Assemble the Left panel (E) and Right panel (F) to the Back panel (C).

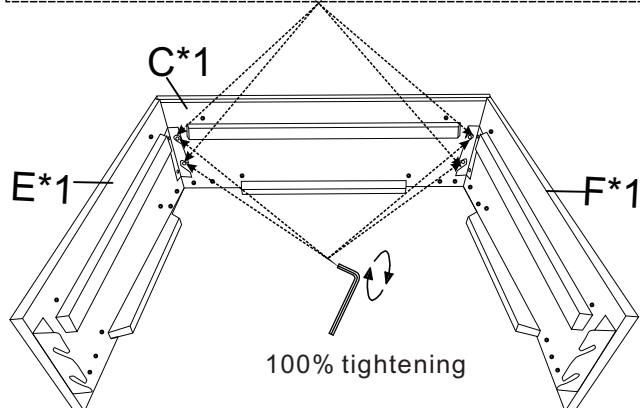
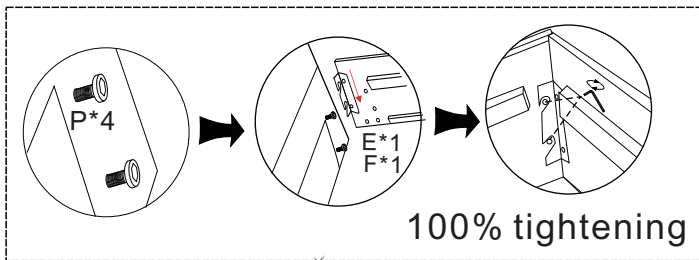

- ④ Assemble the Front panel (D) to the frame.

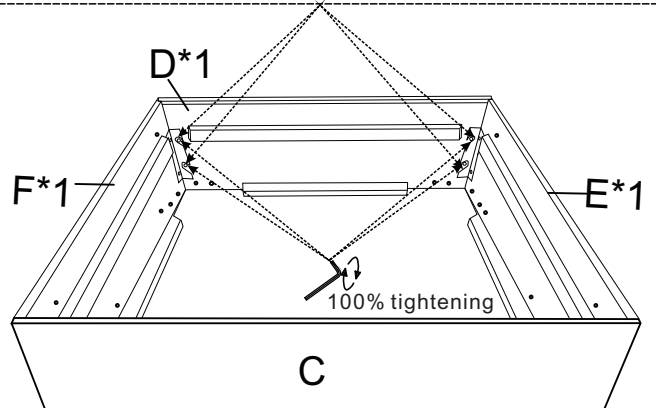
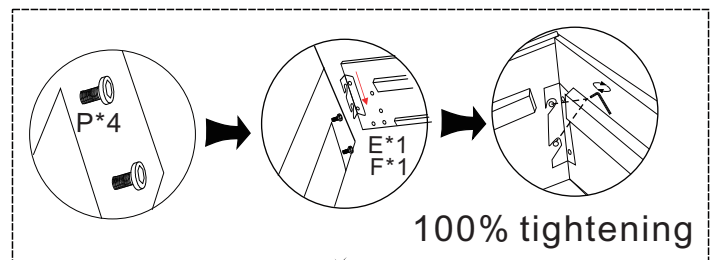

STEP 1

- ⑤ Assemble the Legs (N) into the seat frame with bolts (P).

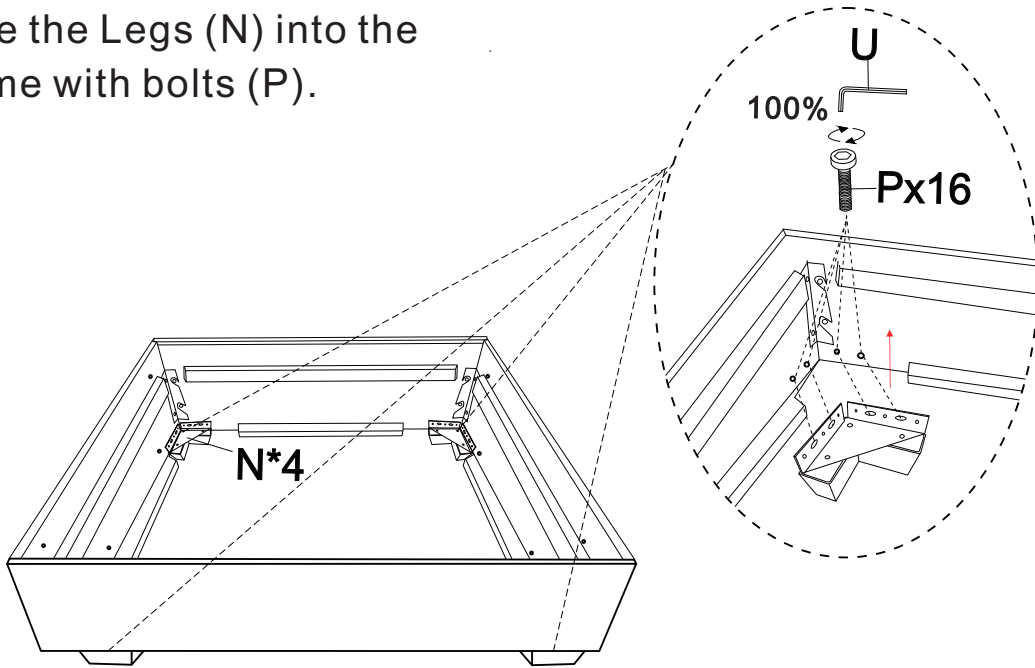

- ⑥ Assemble the Backrest (A) to seat frame with washer (S) and Bolts (Q).

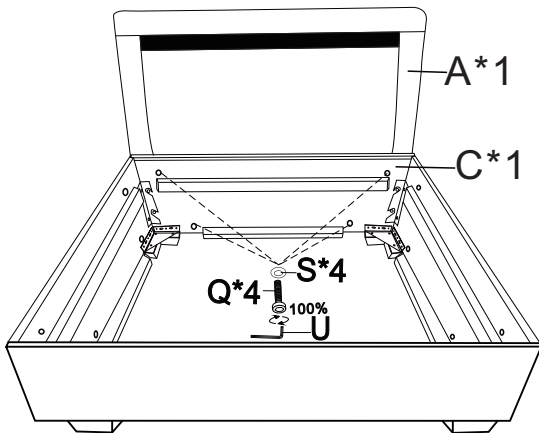

- ⑦ Assemble the leg (O) to the Armrest (B) with plastic gasket (T).

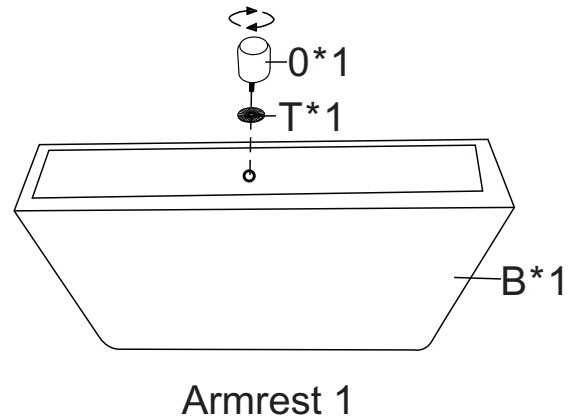

- ⑧ Assemble the leg (O) to the Armrest (B) with plastic gasket (T).

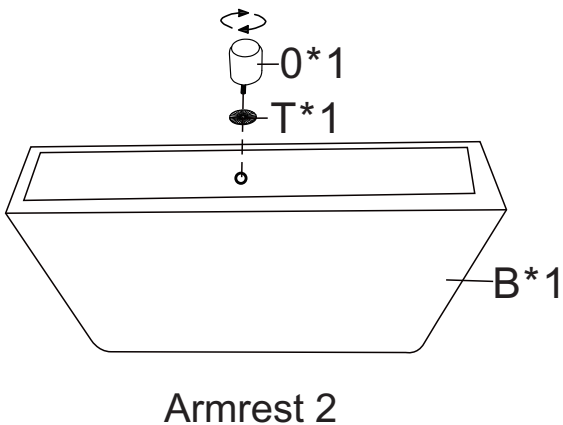

- ⑨ Assemble the Armrest (B) to the seat frame with washer (S) and Bolts (R).

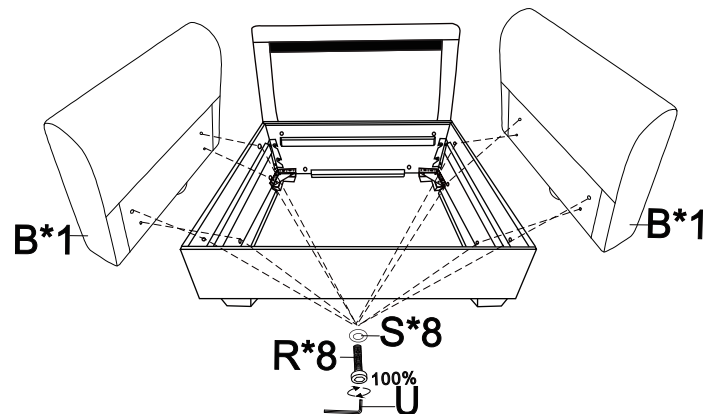

STEP 1

- ⑩ Insert the bottom plate(H) to the bottom of the seat frame.

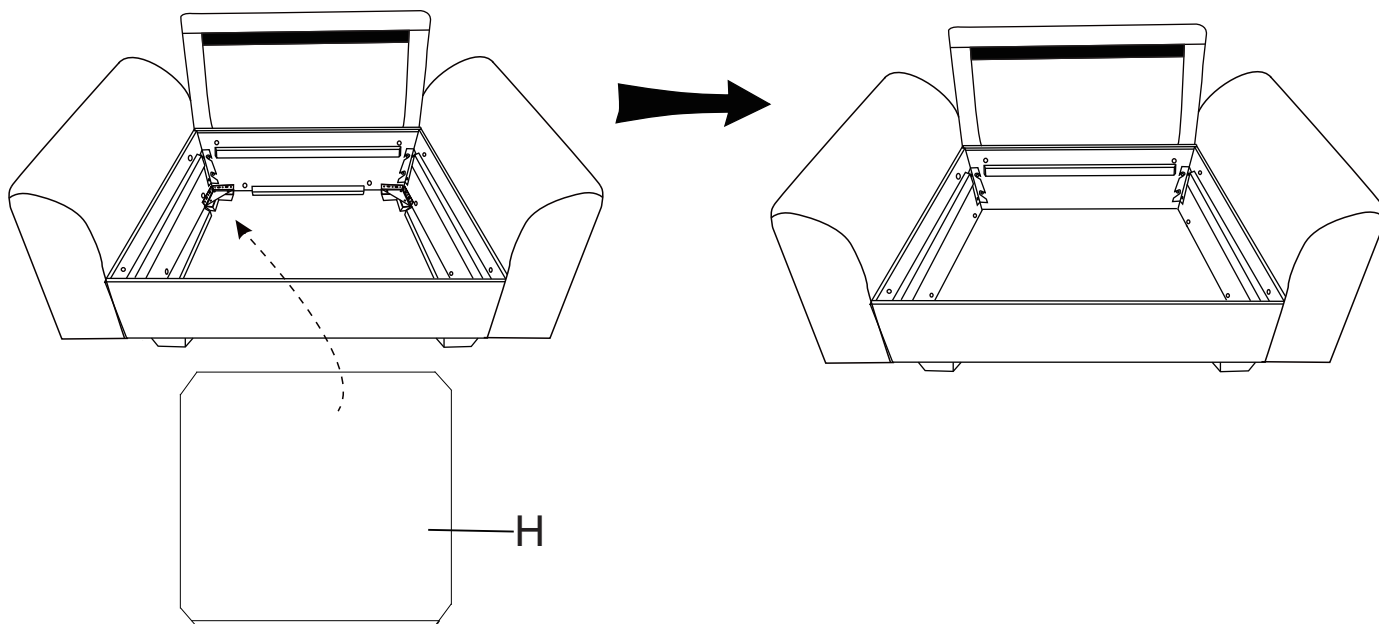

- ⑪ Put the upper cover plate (G) to the seat frame.

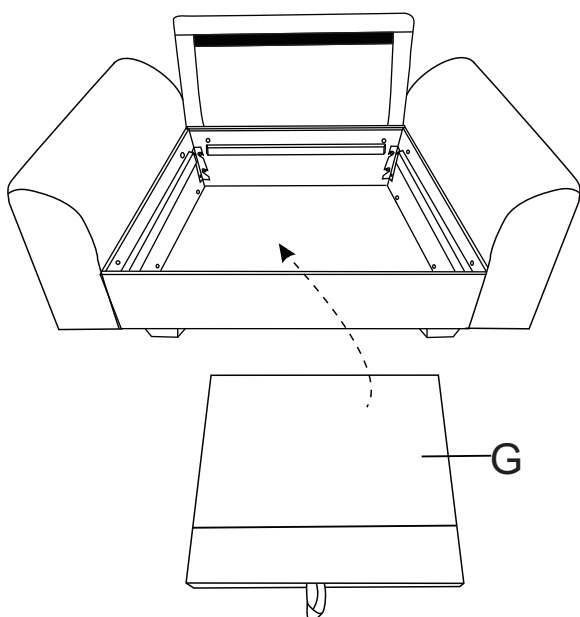

- ⑫ Put the Seat cushion (I) and Small back cushion (K) to the sofa.

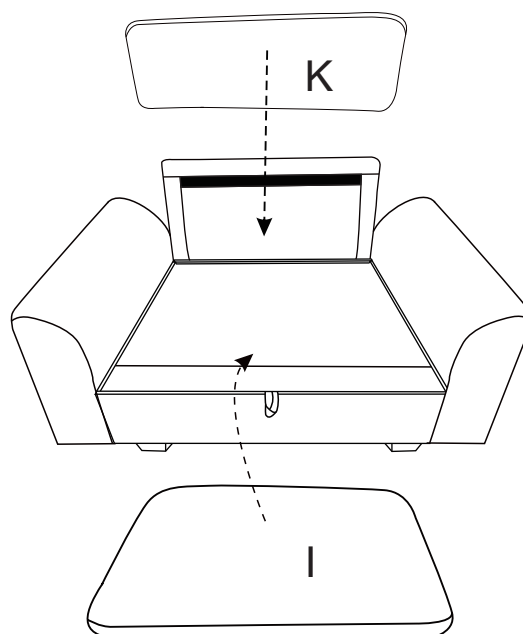

STEP 1

- ⑬ Put the Armrest pillow(J) and Big back cushion (L) on the sofa .

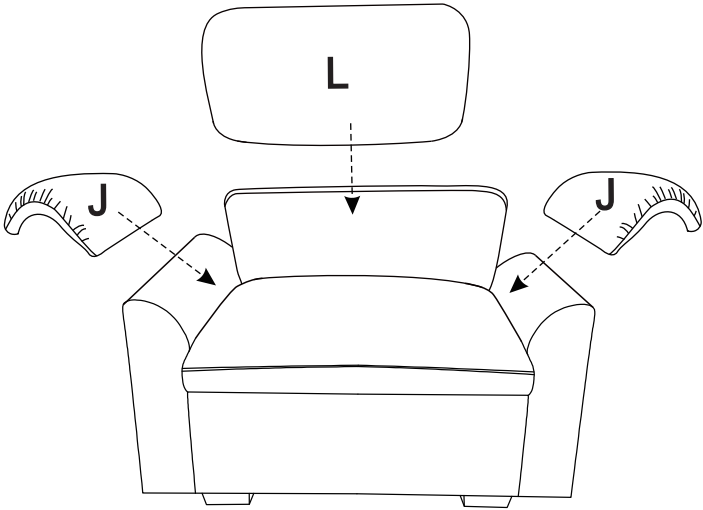

- ⑭ Put the Pillow (M) on sofa .

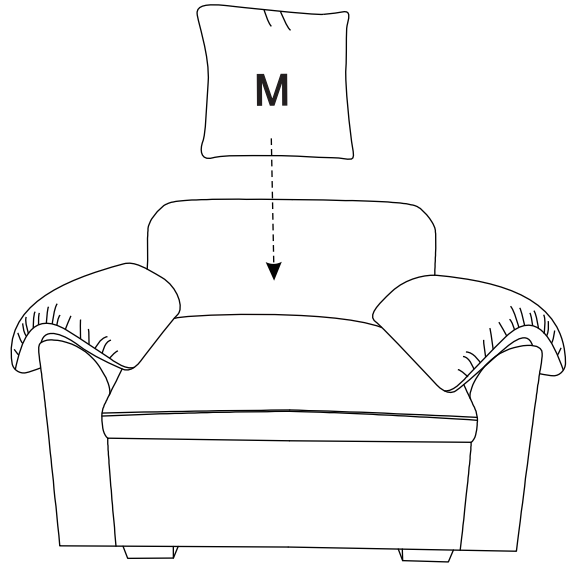



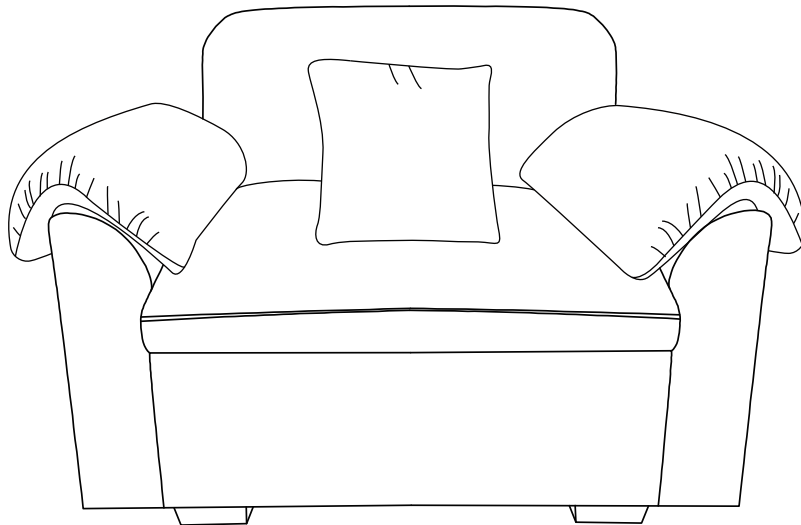







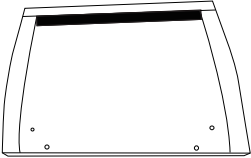
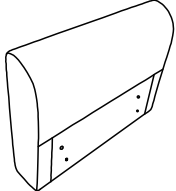
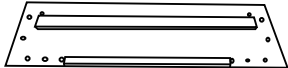
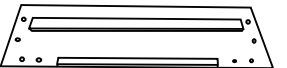

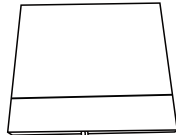
- ⑮ Completed .

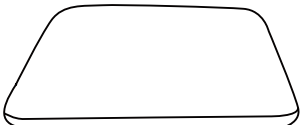
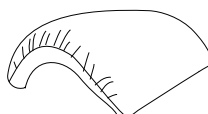

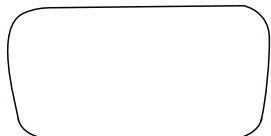
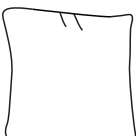
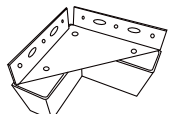
Assembly Instructions

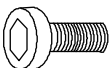
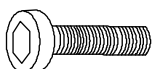
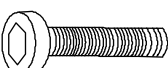
IF YOU BUY 2 SEATER SOFA
please follow below assembly instruction

Parts List

<p>A</p>  <p>Backrest*2</p>	<p>B</p>  <p>Armrest*2</p>	<p>C</p>  <p>Back panel*2</p>	<p>D</p>  <p>Front panel*2</p>	
<p>E</p>  <p>Left panel*2</p>	<p>F</p>  <p>Right panel*2</p>	<p>G</p>  <p>Upper cover plate*2</p>	<p>H</p>  <p>Bottom plate*2</p>	
<p>I</p>  <p>Seat cushion*2</p>	<p>J</p>  <p>Armrest pillow*2</p>	<p>K</p>  <p>Small back cushion*2</p>	<p>L</p>  <p>Big back cushion*2</p>	
<p>M</p>  <p>Pillow*2</p>	<p>N</p>  <p>Leg*8</p>	<p>O</p>  <p>Leg*2</p>	<p>P</p>  <p>Bolt*48 M8*18mm</p>	<p>Q</p>  <p>Bolt*8 M8*30mm</p>
<p>R</p>  <p>Bolt*12 M8*50mm</p>	<p>S</p>  <p>Washer*20</p>	<p>T</p>  <p>Plastic gasket*2</p>	<p>U</p>  <p>Allen Key*2</p>	<p>V</p>  <p>Butterfly nut*4</p>

Note: Please retain all boxes until you are certain that your product isn't damaged and that you do not wish to return it. Disposal of boxes may prevent our ability to resolve your request.

STEP 2

- ① Assemble the Back panel (C) with bolts (P).

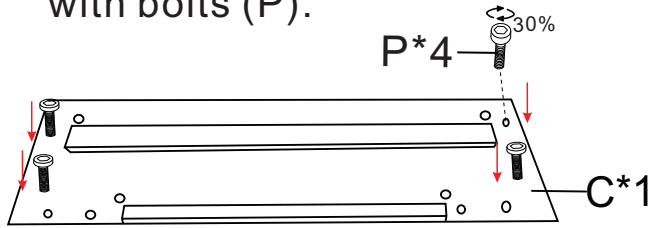

Screw tightening 30%

Back panel 1

- ② Assemble the Back panel (C) with bolts (P).

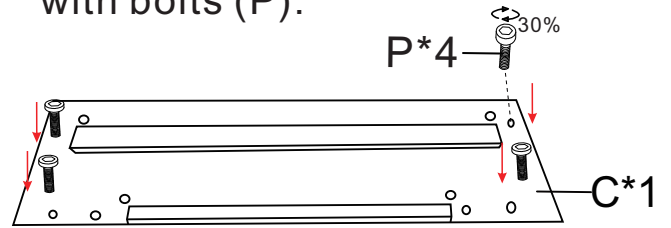

Screw tightening 30%

Back panel 2

- ③ Assemble the Front panel (D) with bolts (P).

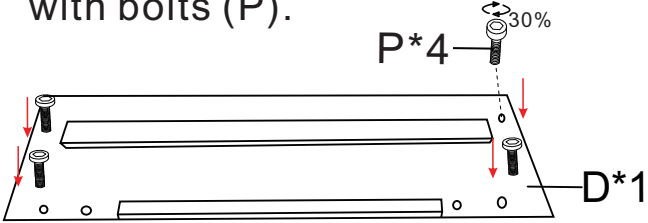

Screw tightening 30%

Front panel 1

- ④ Assemble the Front panel (D) with bolts (P).

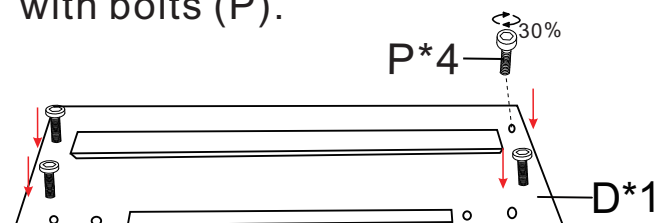

Screw tightening 30%

Front panel 2

- ⑤ Assemble the Left panel (E) and Right panel (F) to the Back panel (C).

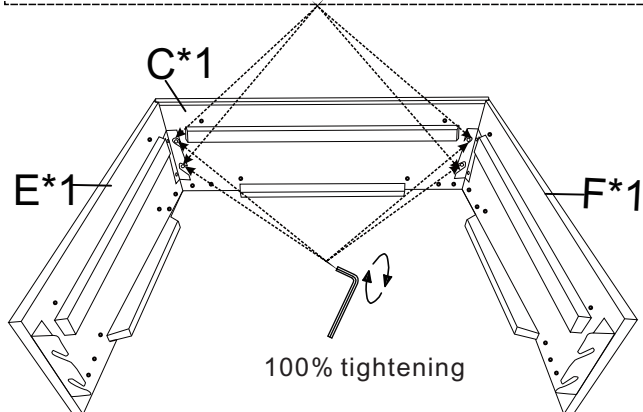
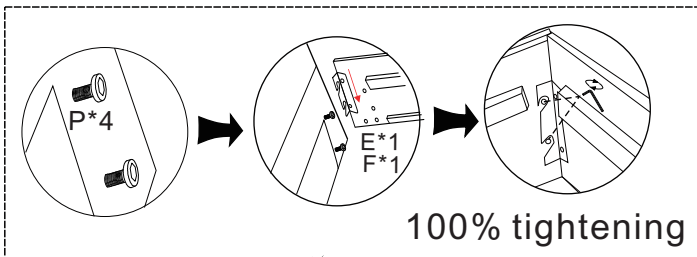

- ⑥ Assemble the Front panel (D) to the frame.

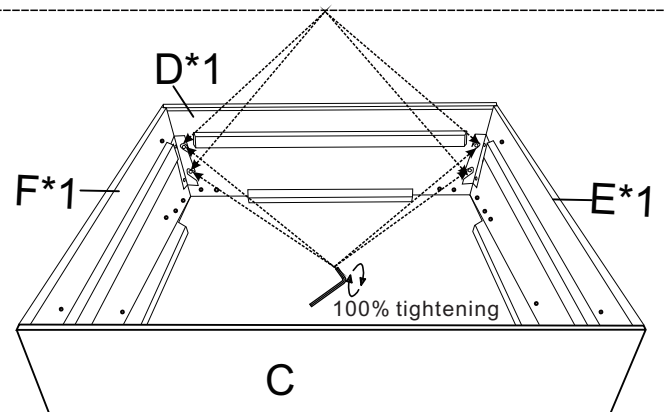
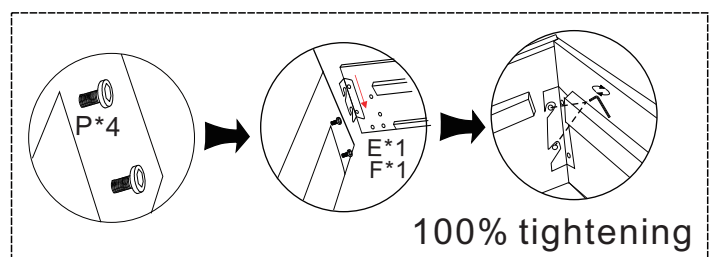

STEP 2

- ⑦ Assemble the Left panel (E) and Right panel (F) to the Back panel (C).

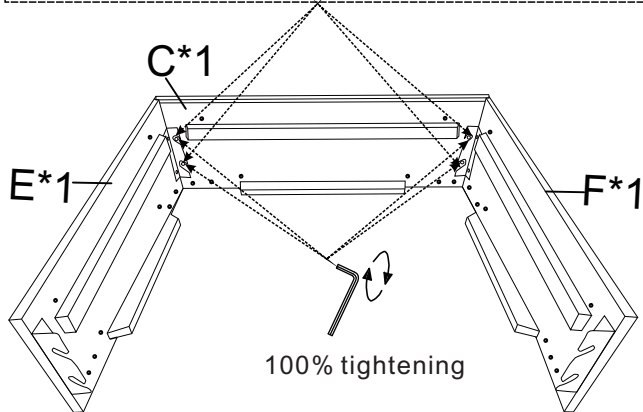
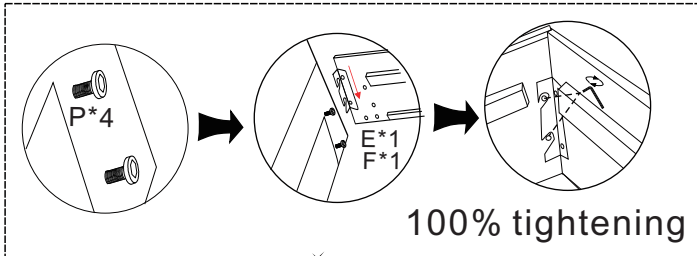

- ⑧ Assemble the Front panel (D) to the frame.

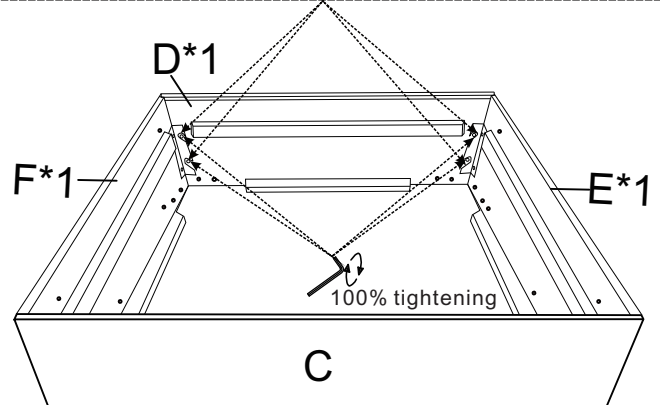
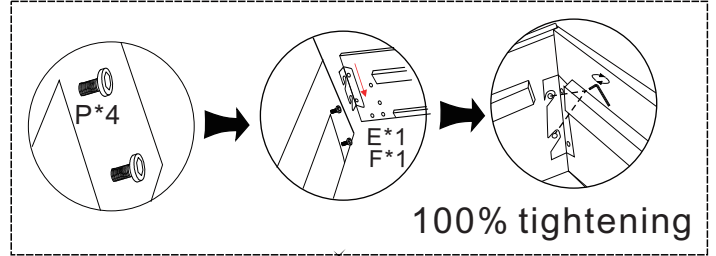

- ⑨ Assemble the Legs (N) into the seat frame with bolts (P).

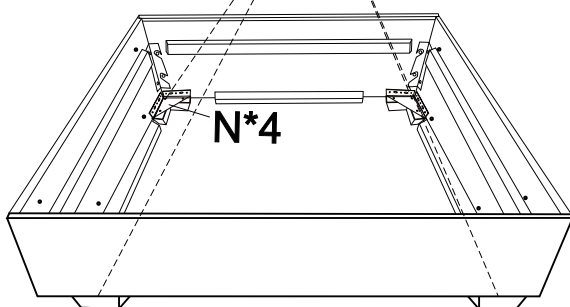
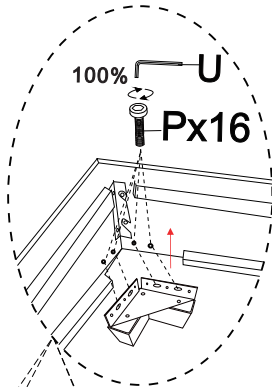

Seat frame 1

- ⑩ Assemble the Legs (N) into the seat frame with bolts (P).

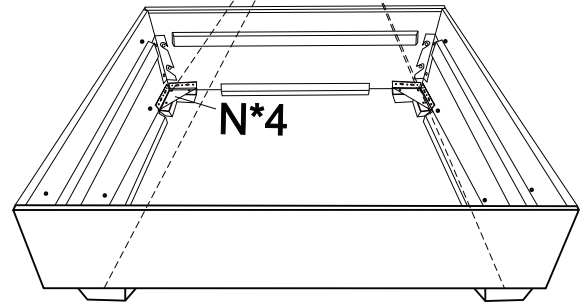
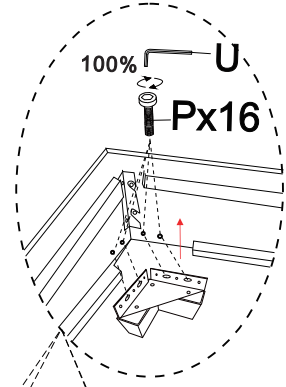

Seat frame 2

STEP 2

- ①① Assemble the Backrest (A) to the seat frame with washer (S) and Bolts(Q).

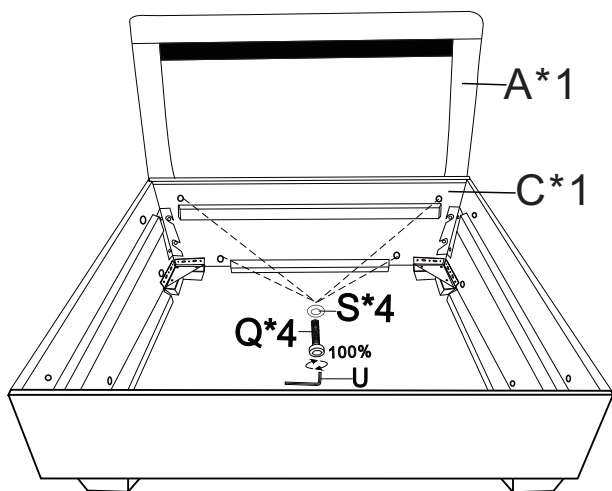

Backrest 1

- ①② Assemble the Backrest (A) to the seat frame with washer (S) and Bolts(Q).

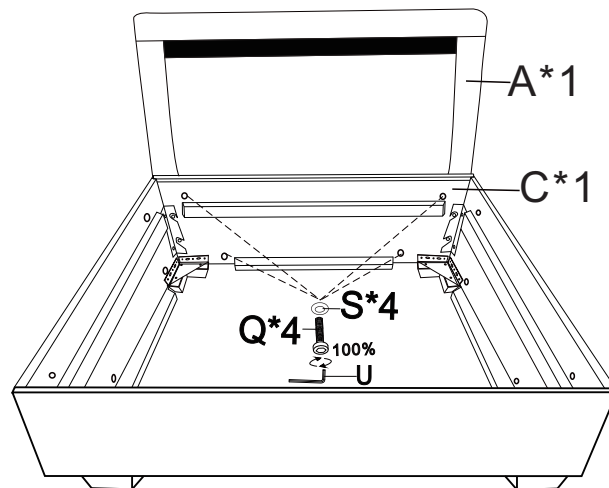

Backrest 2

- ①③ Assemble the leg(O) to the Armrest(B) with plastic gasket (T).

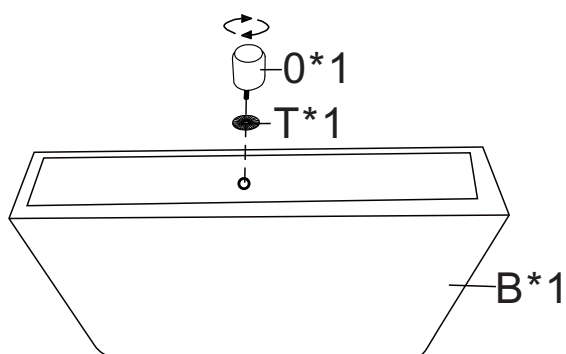

Armrest 1

- ①④ Assemble the Armrest (B) to the seat frame with washer(S) and Bolts(R)

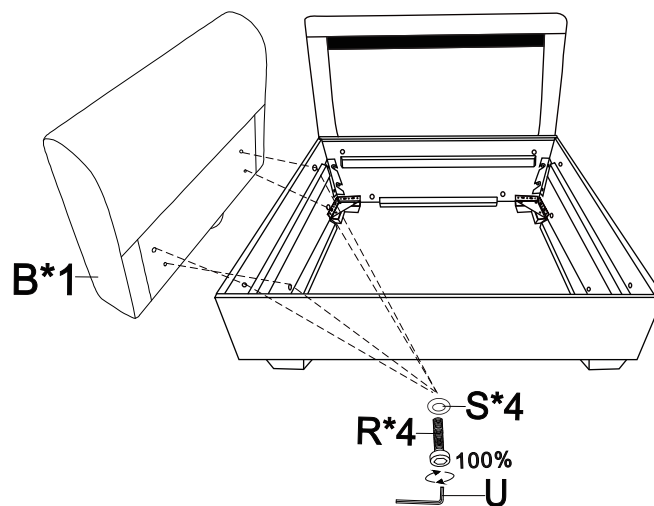

STEP 2

- ⑮ Assemble the leg(O) to the Armrest(B) with plastic gasket (T).

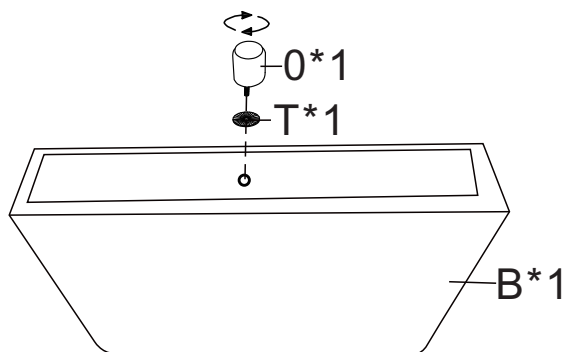

Armrest 2

- ⑯ Assemble the Armrest (B) to the seat frame with washer(S) and Bolts(R)

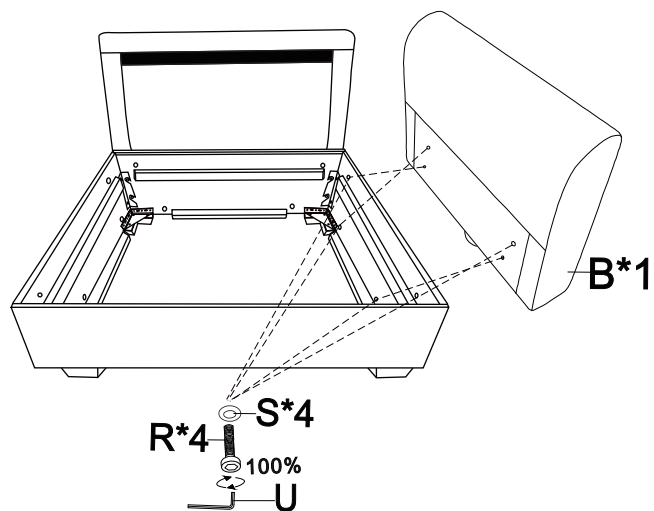

- ⑰ Insert the bottom plate(H) to the bottom of the seat frame.

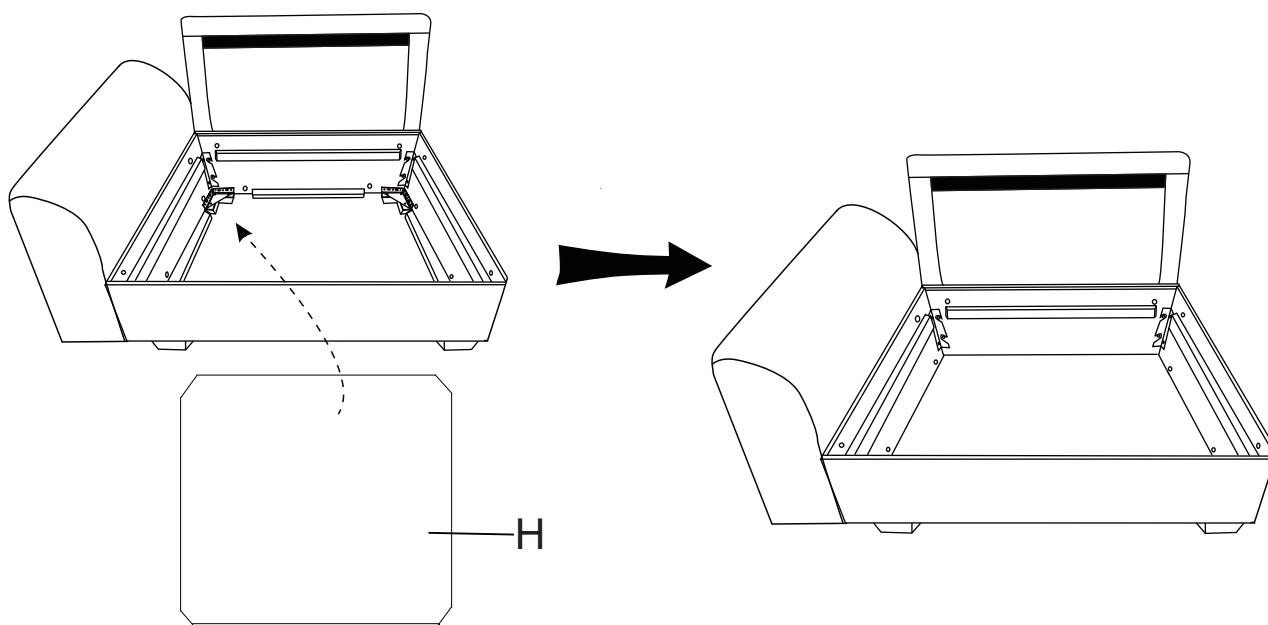

STEP 2

- ⑱ Insert the bottom plate(H) to the bottom of the seat frame.

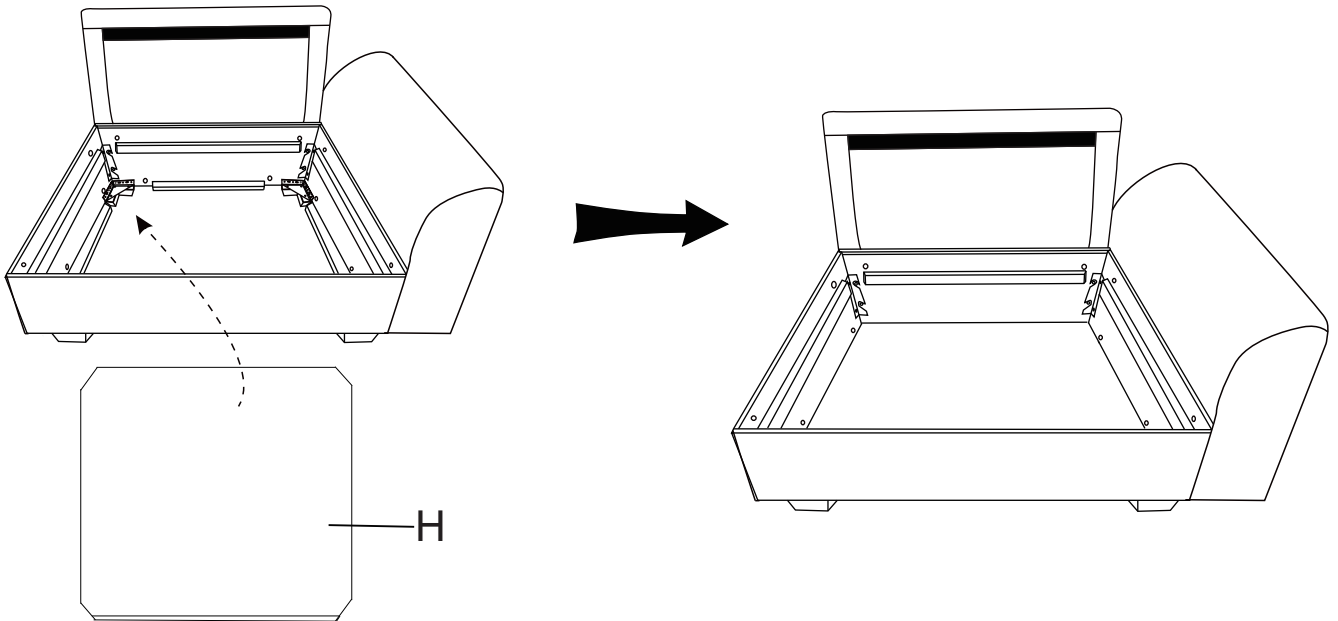

- ⑲ Connect the two seats with Washer(S) and Bolts(R) and Butterfly nut (V).

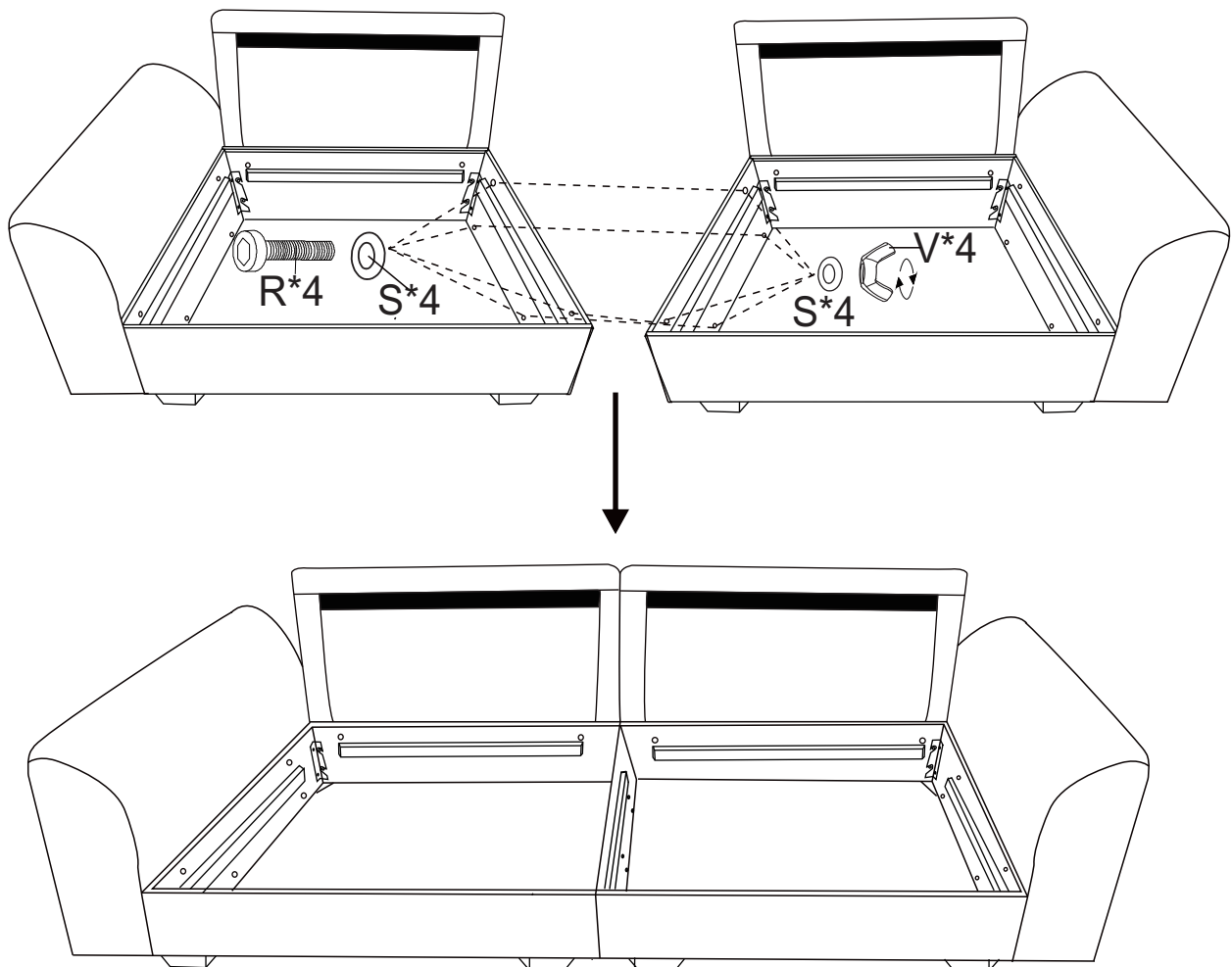

STEP 2

- ②① Put the upper cover plate(G) to the Sofa.

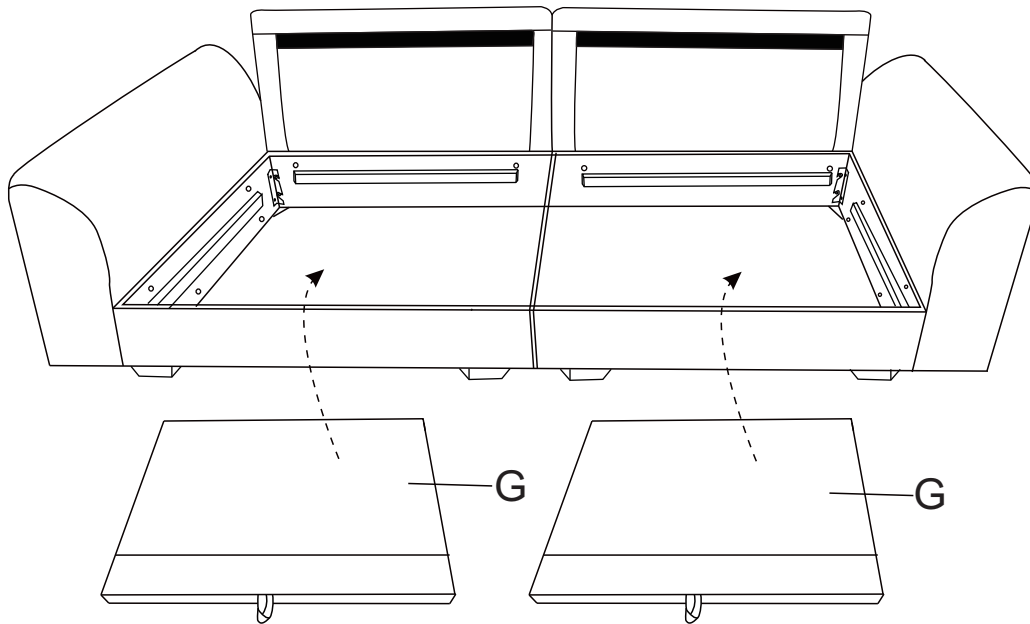

- ②② Put the Seat cushion(I) and Small back cushion (K) to the sofa.

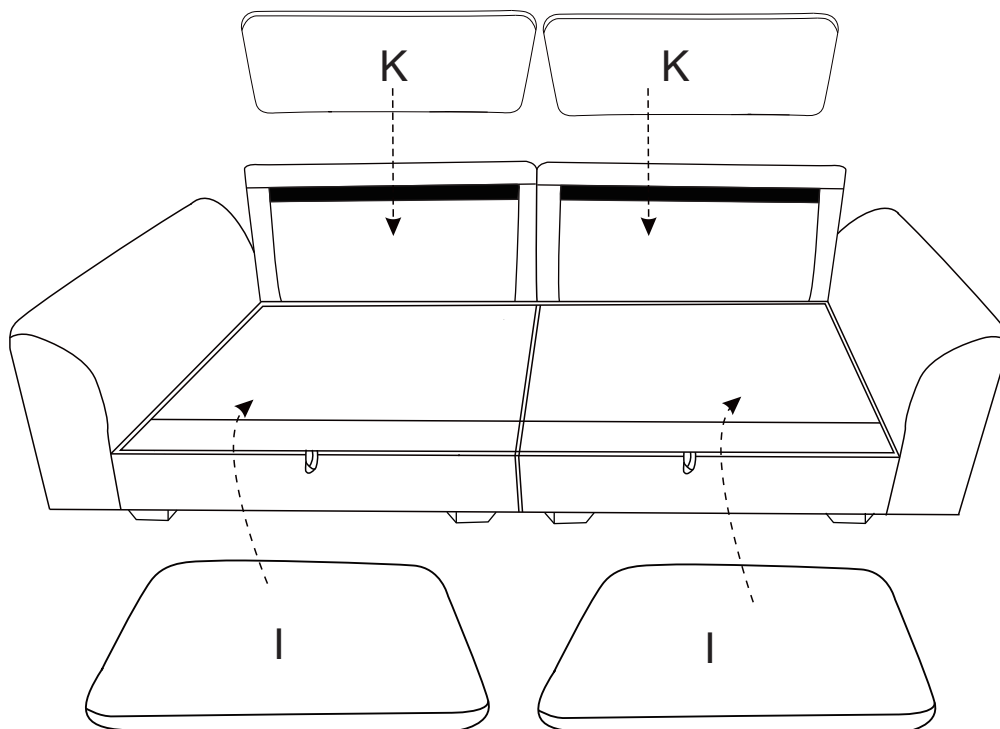

STEP 2

- 22 Put the Armrest pillow (J) and Big back cushion(L) and Pillow (M) on the sofa .

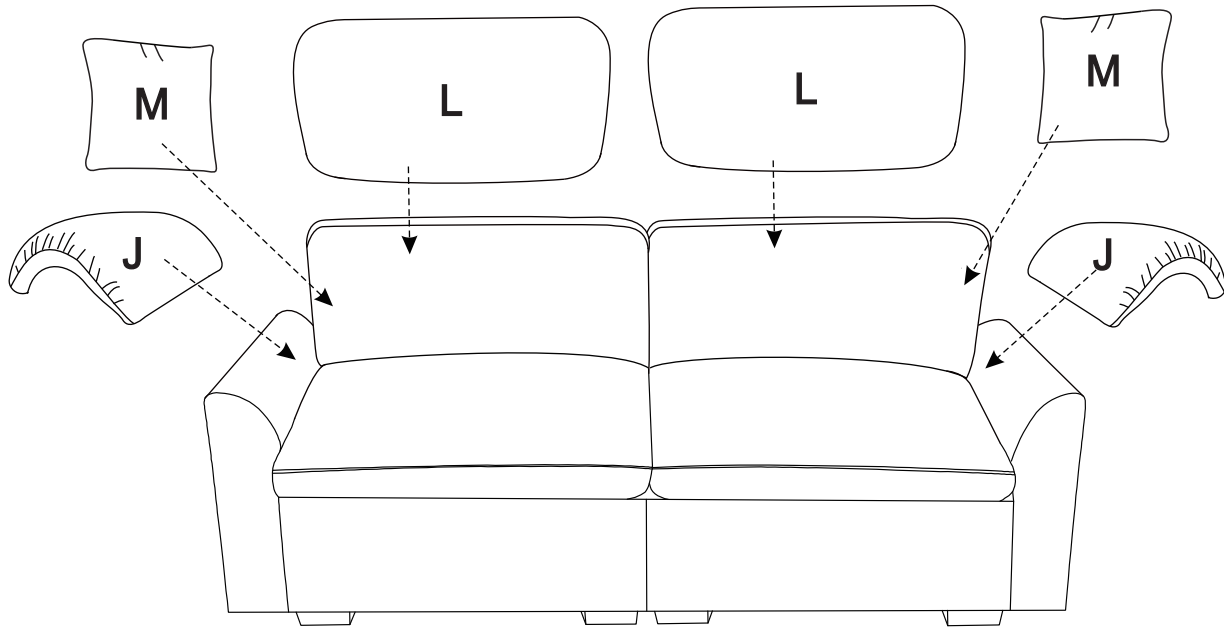



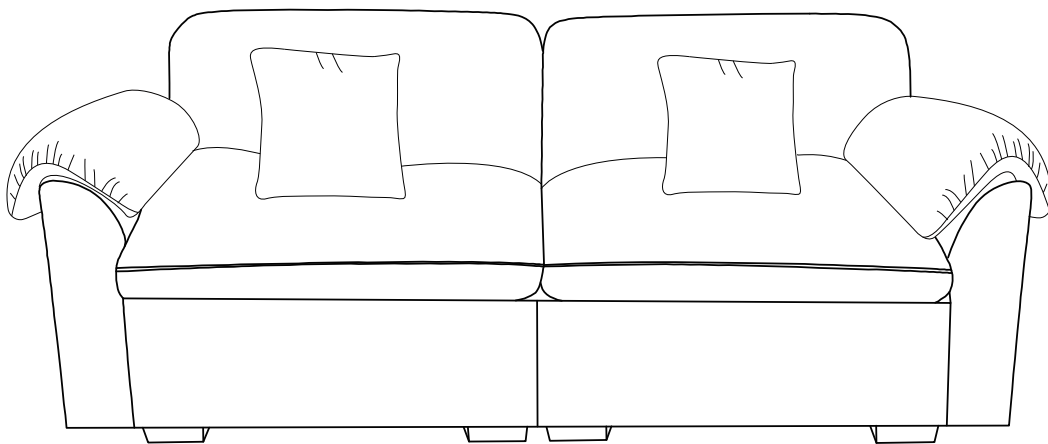







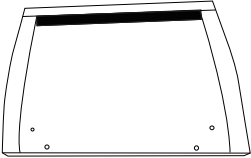
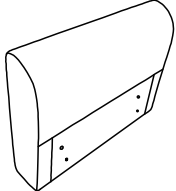
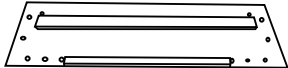
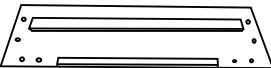

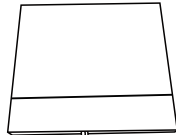
- 23 Completed .

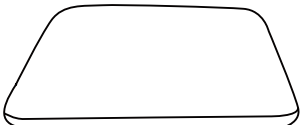
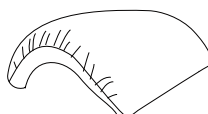

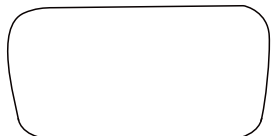
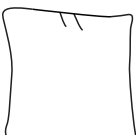
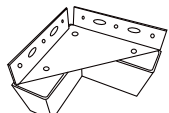
Assembly Instructions

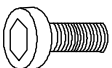
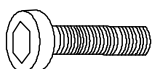
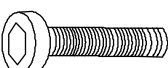
IF YOU BUY 3 SEATER SOFA
please follow below assembly instruction

Parts List

<p>A</p>  <p>Backrest*3</p>	<p>B</p>  <p>Armrest*2</p>	<p>C</p>  <p>Back panel*3</p>	<p>D</p>  <p>Front panel*3</p>	
<p>E</p>  <p>Left panel*3</p>	<p>F</p>  <p>Right panel*3</p>	<p>G</p>  <p>Upper cover plate*3</p>	<p>H</p>  <p>Bottom plate*3</p>	
<p>I</p>  <p>Seat cushion*3</p>	<p>J</p>  <p>Armrest pillow*2</p>	<p>K</p>  <p>Small back cushion*3</p>	<p>L</p>  <p>Big back cushion*3</p>	
<p>M</p>  <p>Pillow*3</p>	<p>N</p>  <p>Leg*12</p>	<p>O</p>  <p>Leg*2</p>	<p>P</p>  <p>Bolt*72 M8*18mm</p>	<p>Q</p>  <p>Bolt*12 M8*30mm</p>
<p>R</p>  <p>Bolt*16 M8*50mm</p>	<p>S</p>  <p>Washer*28</p>	<p>T</p>  <p>Plastic gasket*2</p>	<p>U</p>  <p>Allen Key*3</p>	<p>V</p>  <p>Butterfly nut*8</p>

Note: Please retain all boxes until you are certain that your product isn't damaged and that you do not wish to return it. Disposal of boxes may prevent our ability to resolve your request.

STEP 3

- ① Assemble the Back panel(C) with bolts(P).

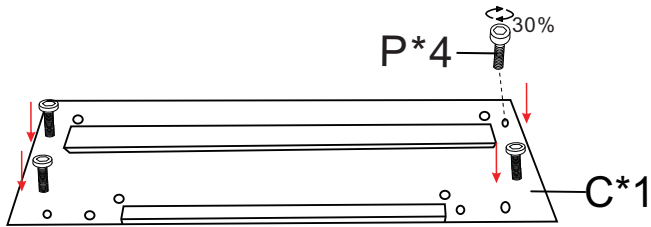

Screw tightening 30%
Back panel 1

- ② Assemble the Back panel(C) with bolts(P).

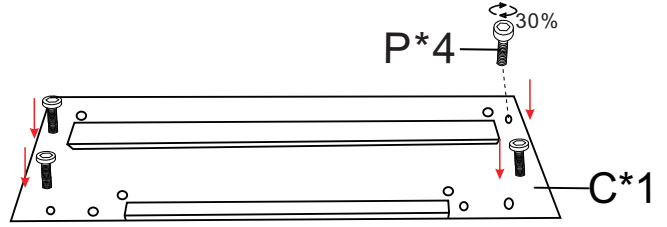

Screw tightening 30%
Back panel 2

- ③ Assemble the Back panel(C) with bolts(P).

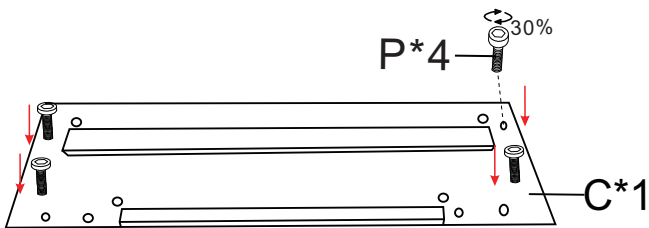

Screw tightening 30%
Back panel 3

- ④ Assemble the Front panel(D) with bolts(P).

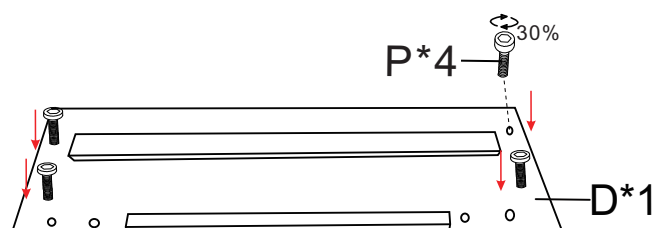

Screw tightening 30%
Front panel 1

- ⑤ Assemble the Front panel(D) with bolts(P).

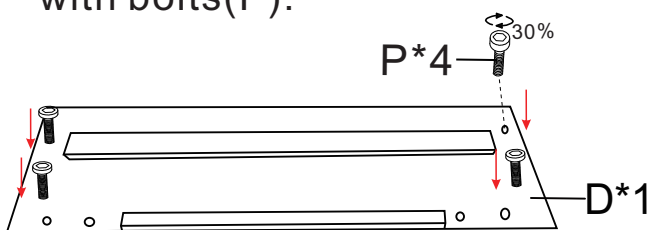

Screw tightening 30%
Front panel 2

- ⑥ Assemble the Front panel(D) with bolts(P).

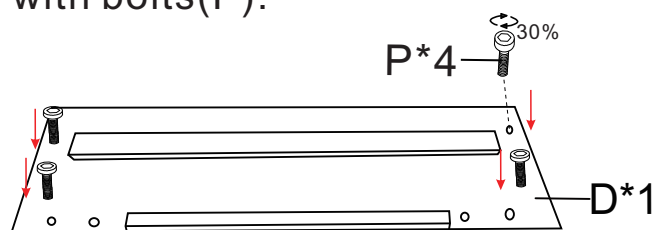

Screw tightening 30%
Front panel 3

STEP 3

- ⑦ Assemble the Left panel(E) and Right panel (F) to the Back panel(C).

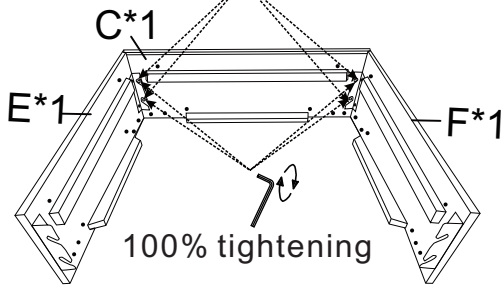
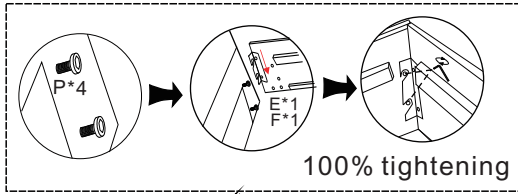

- ⑧ Assemble the Front panel(D) to the frame.

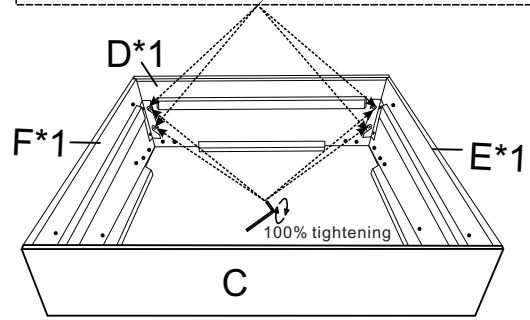
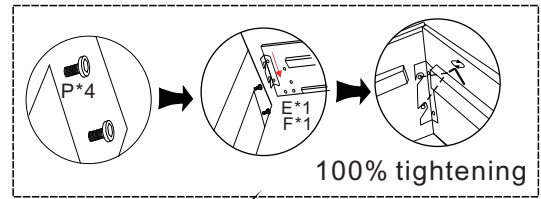

- ⑨ Assemble the Left panel(E) and Right panel (F) to the Back panel(C).

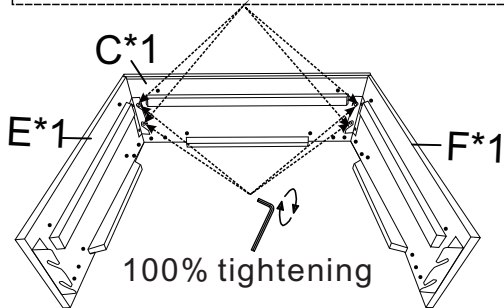
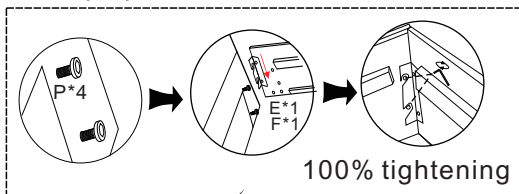

- ⑩ Assemble the Front panel(D) to the frame.

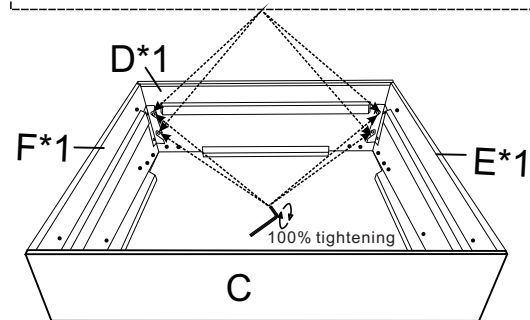
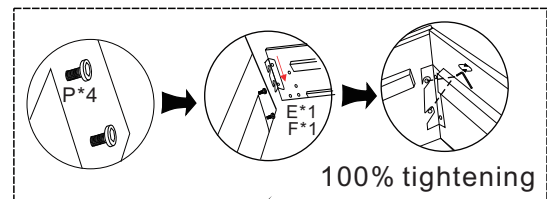

- ⑪ Assemble the Left panel(E) and Right panel (F) to the Back panel(C).

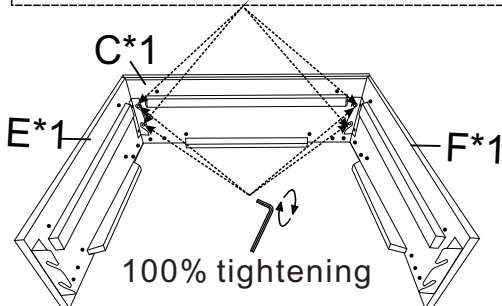
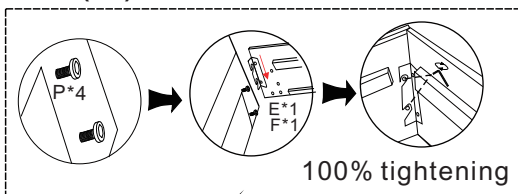

- ⑫ Assemble the Front panel(D) to the frame.

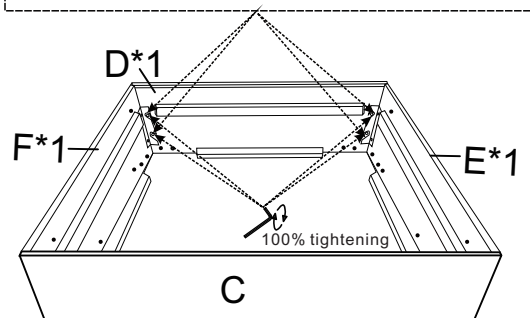
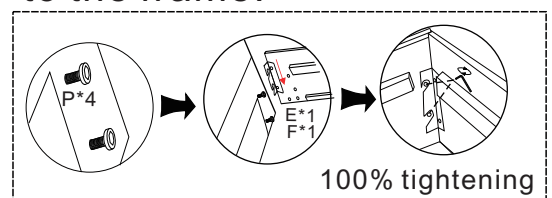

STEP 3

- 13 Assemble the Legs(N) into the seat frame with bolts (P).

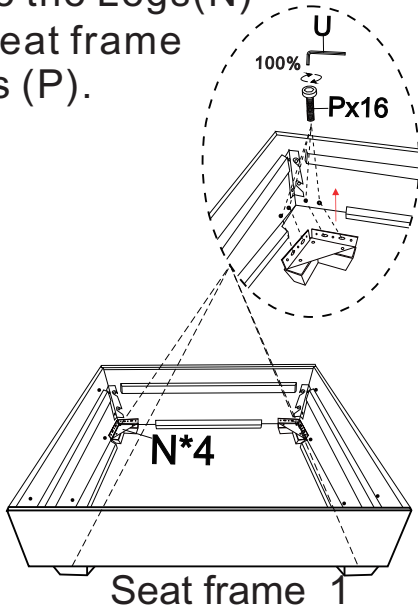

- 14 Assemble the Legs(N) into the seat frame with bolts (P).

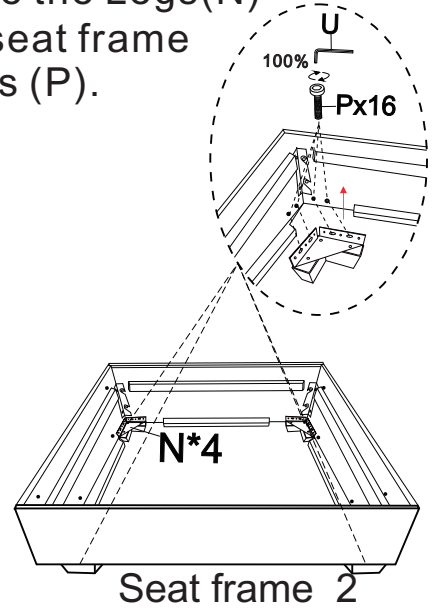

- 15 Assemble the Legs(N) into the seat frame with bolts (P).

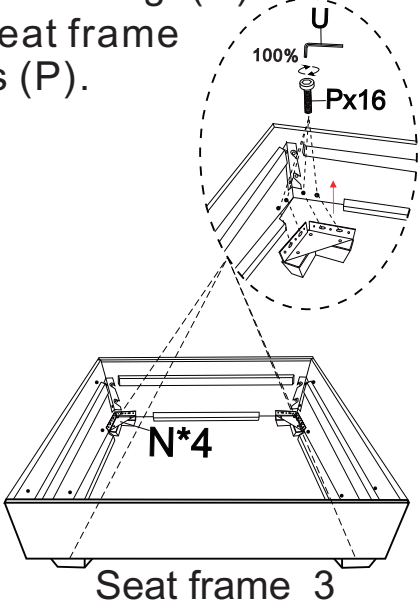

- 16 Assemble the Backrest (A) to the seat frame with washer(S)and Bolts(Q).

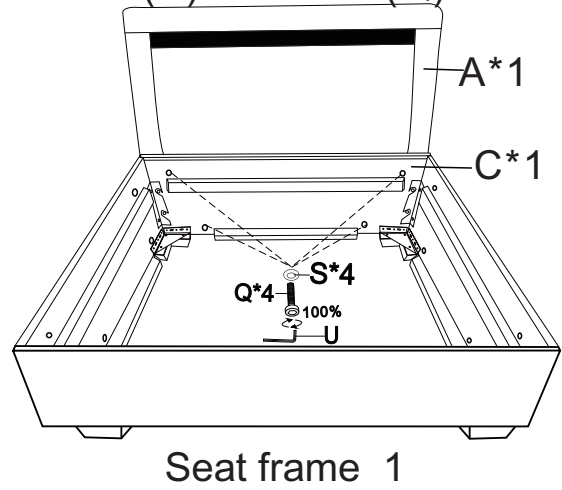

- 17 Assemble the Backrest (A) to the seat frame with washer(S)and Bolts(Q).

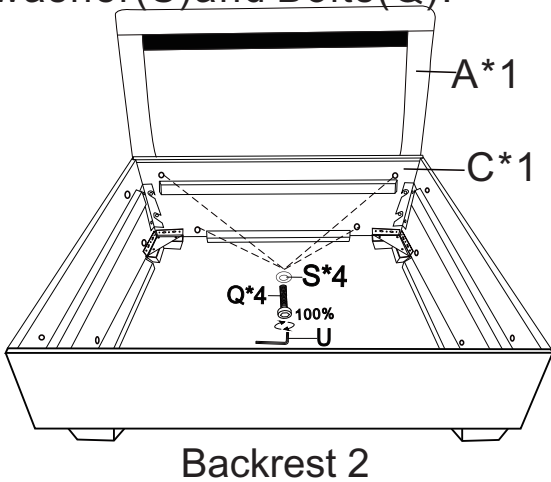

- 18 Assemble the Backrest (A) to the seat frame with washer(S)and Bolts(Q).

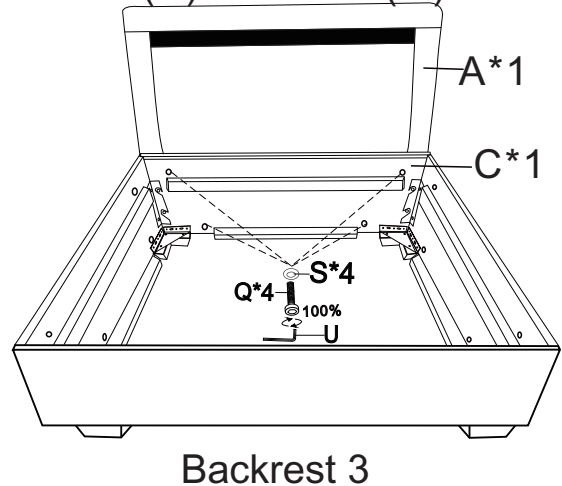

STEP 3

- ①9 Assemble the leg(O) to the Armrest(B).

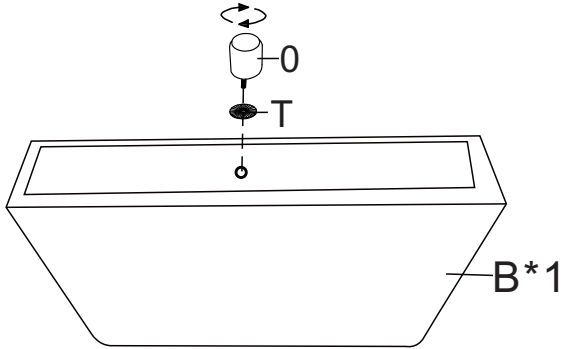

Armrest 1

- ②0 Assemble the Armrest (B) to the seat frame with washer(S)and Bolts(R).

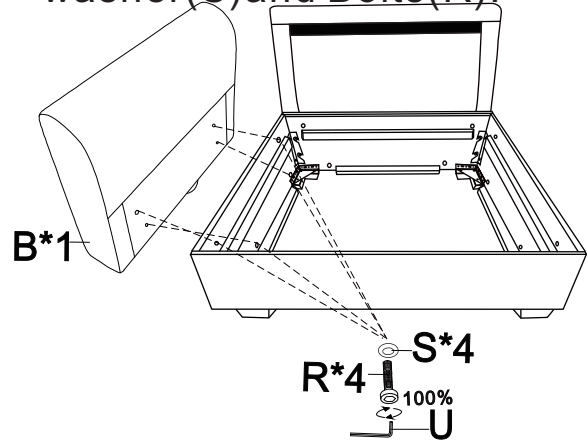

- ②1 Assemble the leg(O) to the Armrest(B).

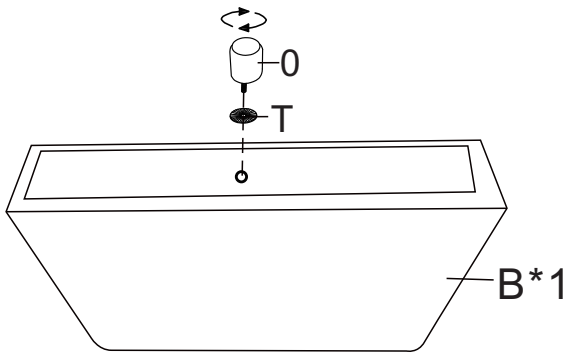

Armrest 2

- ②2 Assemble the Armrest (B) to the seat frame with washer(S)and Bolts(R).

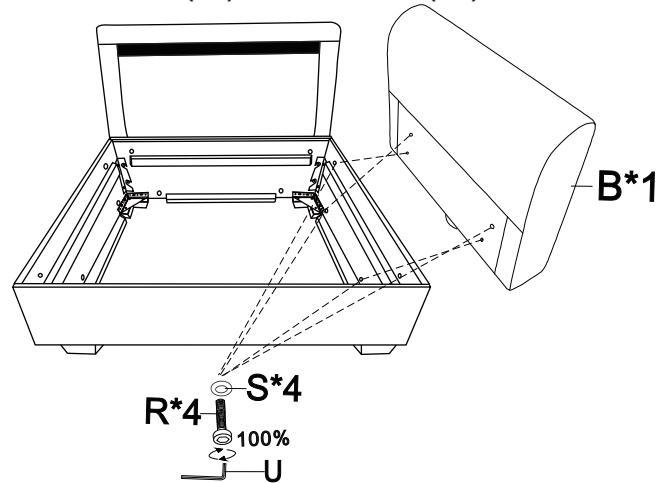

- ②3 Insert the bottom plate(H) to the bottom of the seat frame.

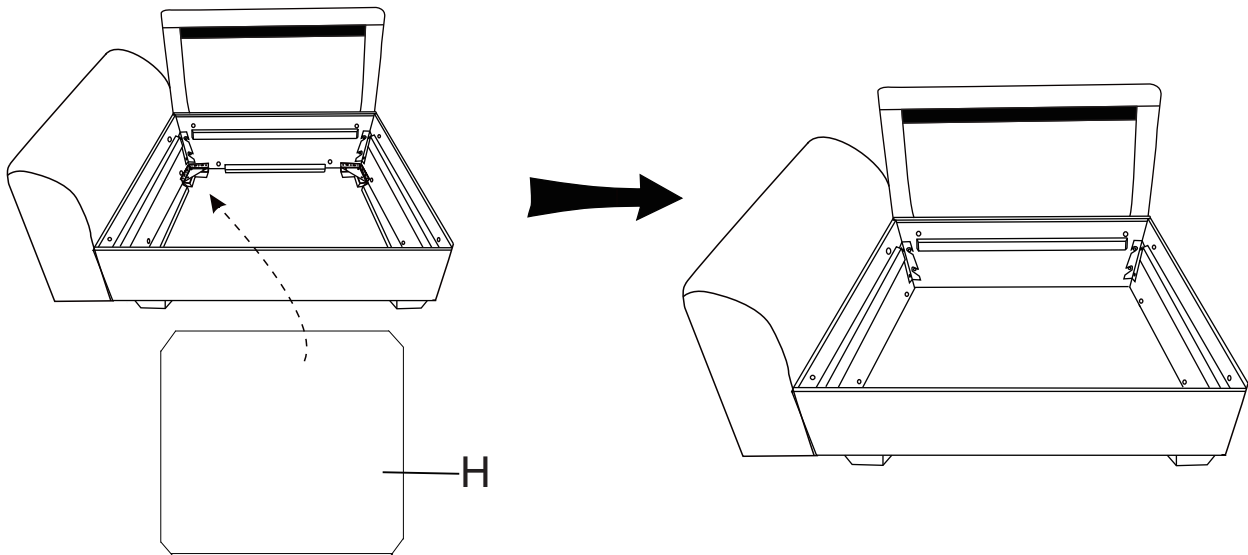

STEP 3

②4 Insert the bottom plate(H) to the bottom of the seat frame.

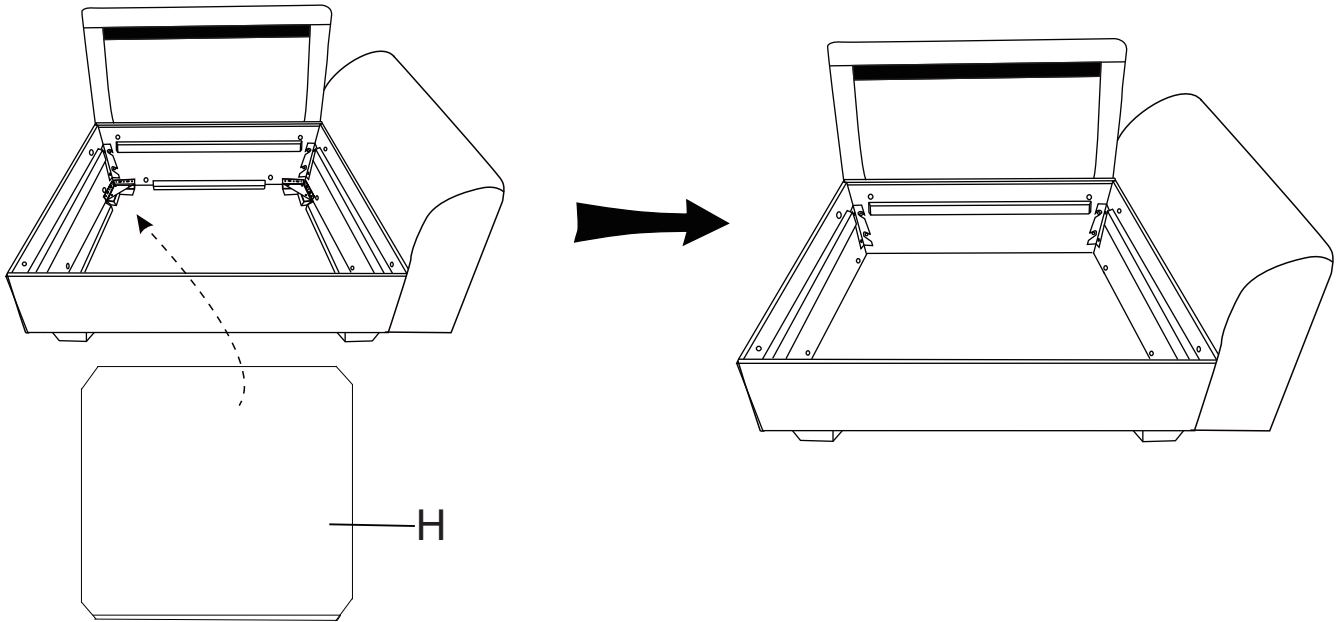

②5 Insert the bottom plate(H) to the bottom of the seat frame.

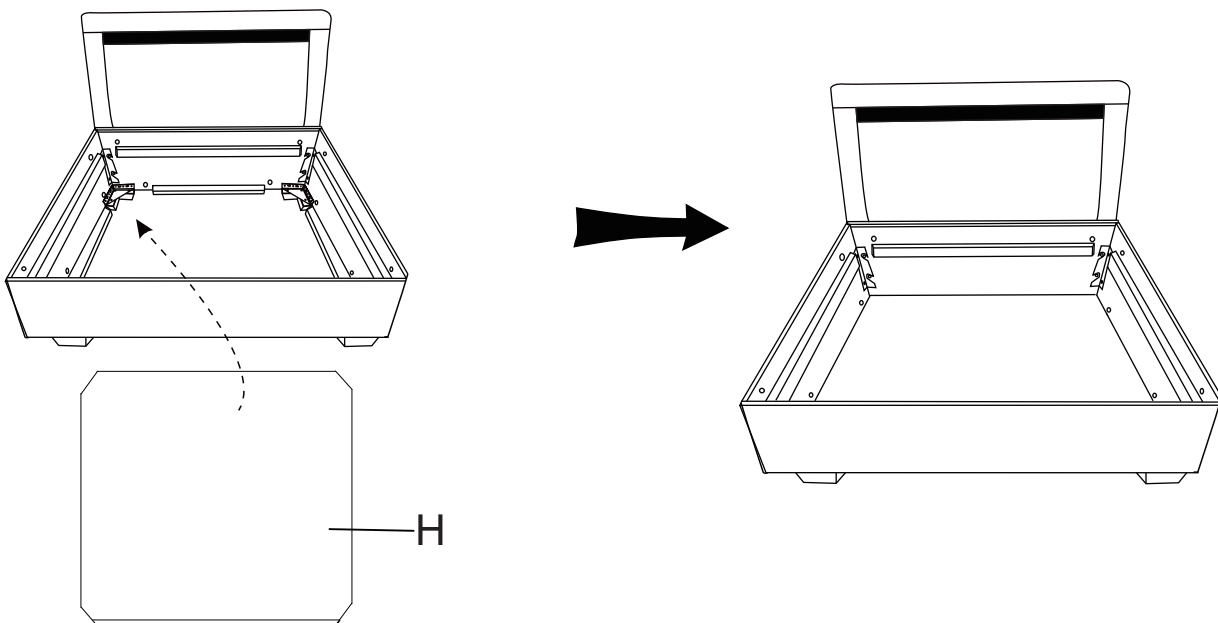

STEP 3

- 26 Connect the three seats with Washer(S) and Bolts(R) and Butterfly nut (V).

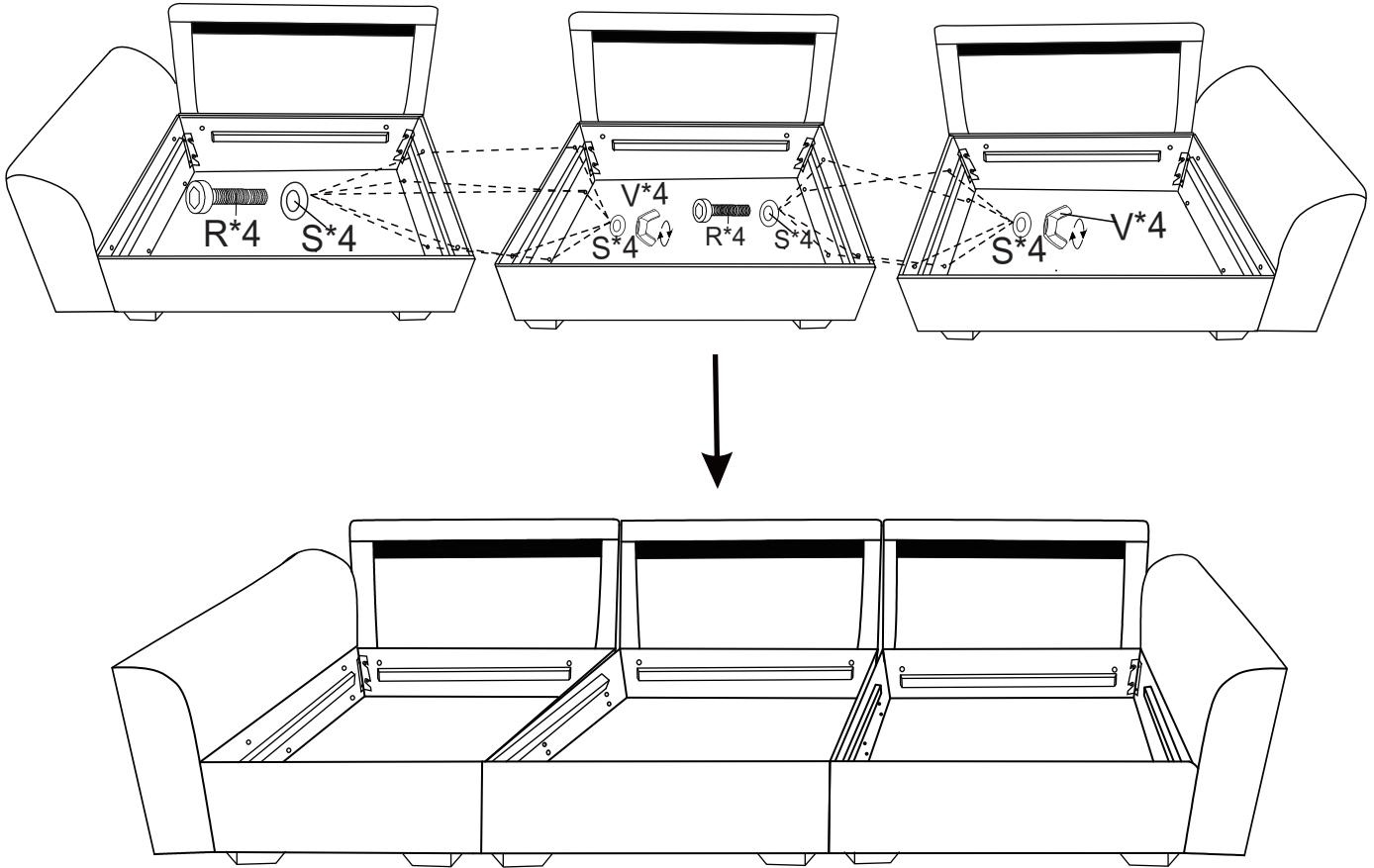

- 27 Put the upper cover plate(G) to the Sofa.

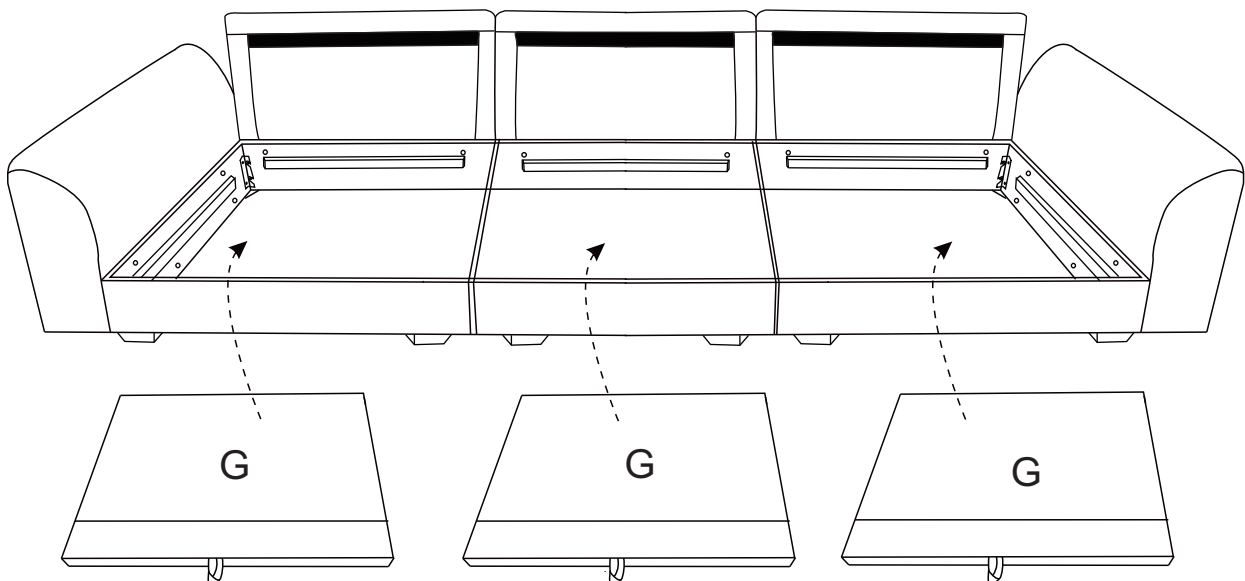

STEP 3

28 Put the Seat cushion(I) and Small back cushion (K)to the sofa.

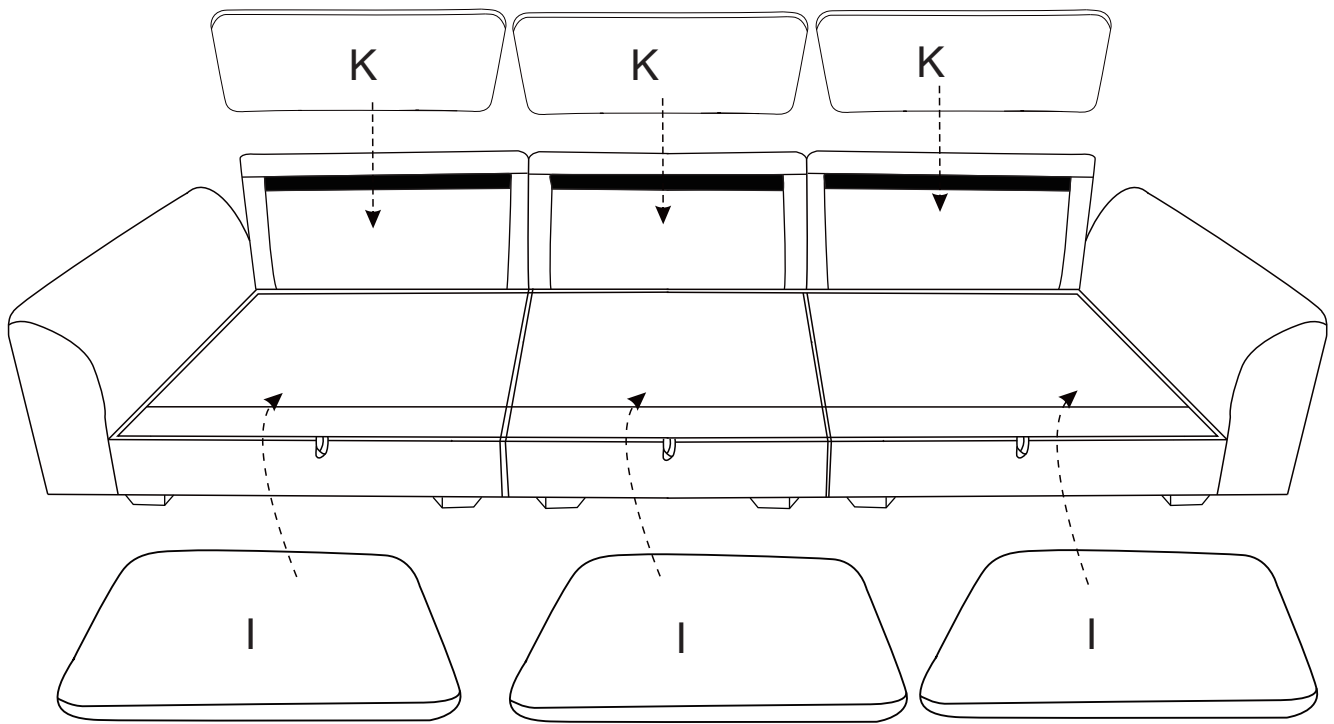

29 Put the Armrest pillow(J) and Big back cushion(L)on the sofa .

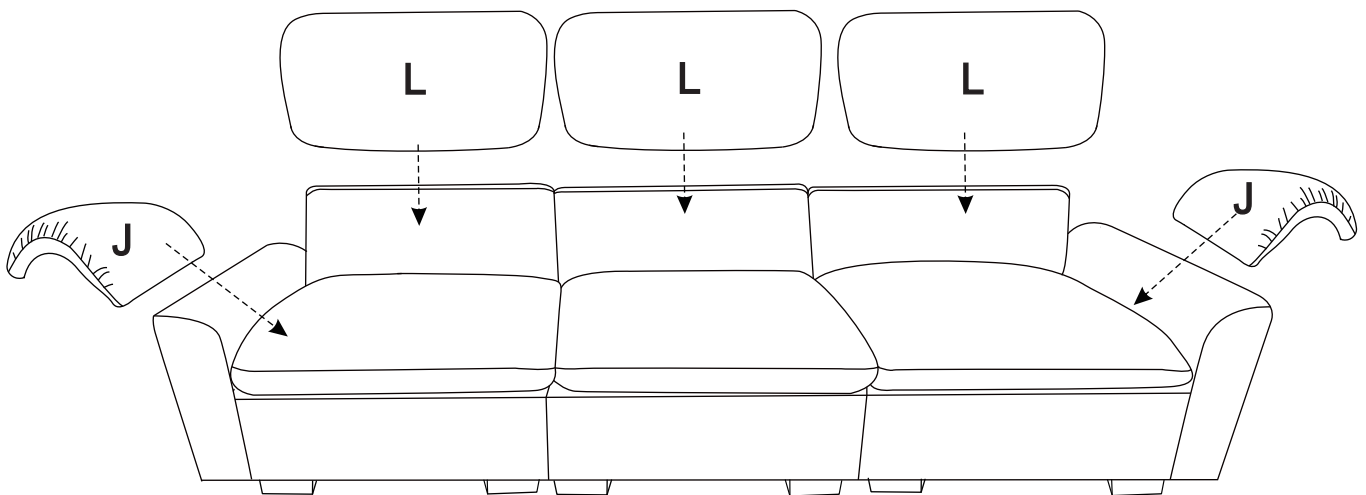

STEP 3

30 Put the Pillow(M) on sofa .

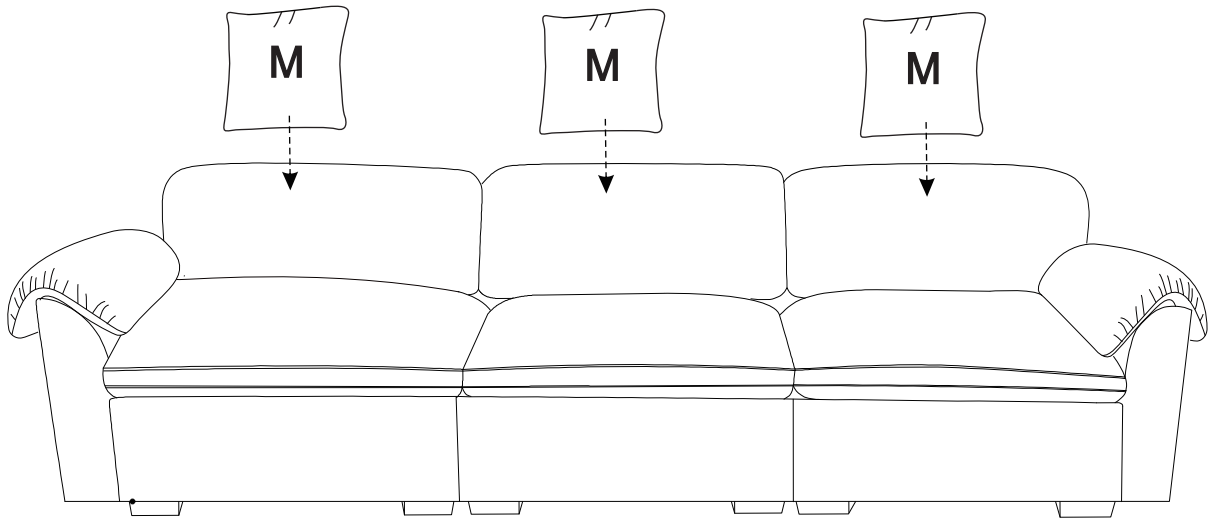



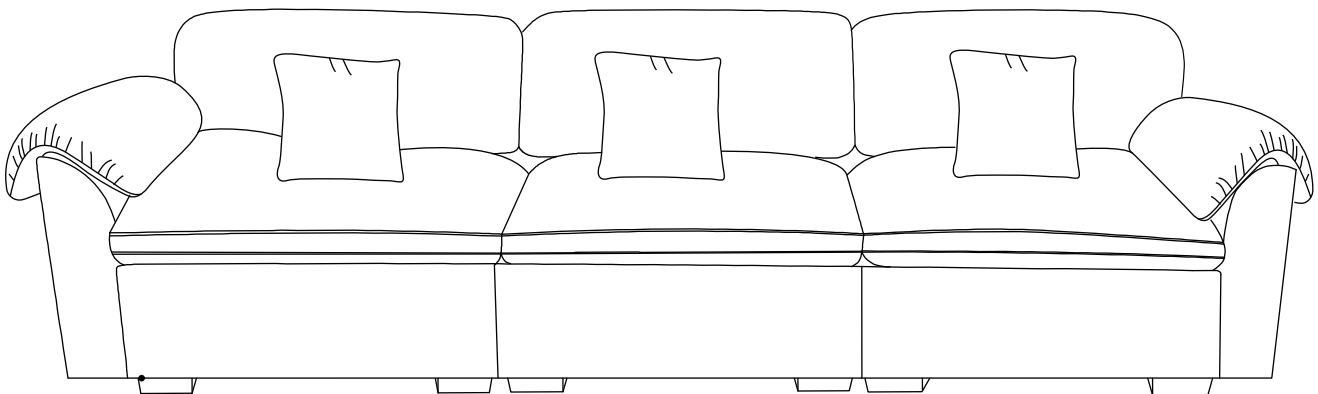







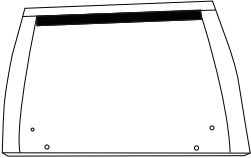
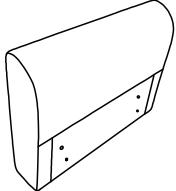
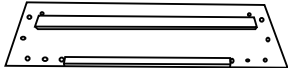
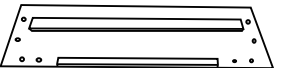

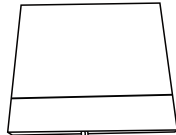
31 Completed .

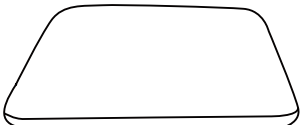
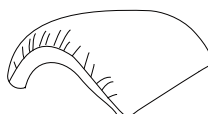

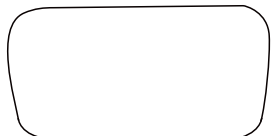
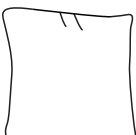
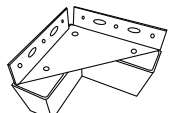
Assembly Instructions

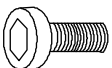
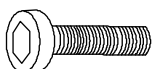
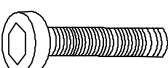
IF YOU BUY 4 SEATER SOFA
please follow below assembly instruction

Parts List

<p>A</p>  <p>Backrest*4</p>	<p>B</p>  <p>Armrest*2</p>	<p>C</p>  <p>Back panel*4</p>	<p>D</p>  <p>Front panel*4</p>	
<p>E</p>  <p>Left panel*4</p>	<p>F</p>  <p>Right panel*4</p>	<p>G</p>  <p>Upper cover plate*4</p>	<p>H</p>  <p>Bottom plate*4</p>	
<p>I</p>  <p>Seat cushion*4</p>	<p>J</p>  <p>Armrest pillow*2</p>	<p>K</p>  <p>Small back cushion*4</p>	<p>L</p>  <p>Big back cushion*4</p>	
<p>M</p>  <p>Pillow*4</p>	<p>N</p>  <p>Leg*16</p>	<p>O</p>  <p>Leg*2</p>	<p>P</p>  <p>Bolt*96 M8*18mm</p>	<p>Q</p>  <p>Bolt*16 M8*30mm</p>
<p>R</p>  <p>Bolt*20 M8*50mm</p>	<p>S</p>  <p>Washer*36</p>	<p>T</p>  <p>Plastic gasket*2</p>	<p>U</p>  <p>Allen Key*4</p>	<p>V</p>  <p>Butterfly nut*12</p>

Note: Please retain all boxes until you are certain that your product isn't damaged and that you do not wish to return it. Disposal of boxes may prevent our ability to resolve your request.

STEP 4

- ① Assemble the Back panel(C) with bolts(P).

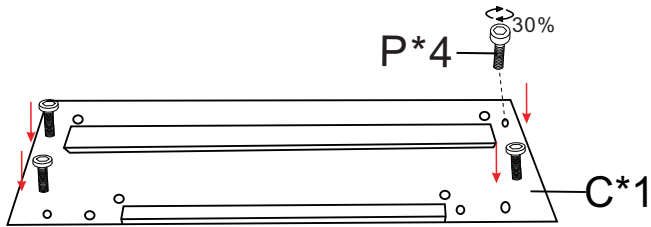

Screw tightening 30%

Back panel 1

- ② Assemble the Back panel(C) with bolts(P).

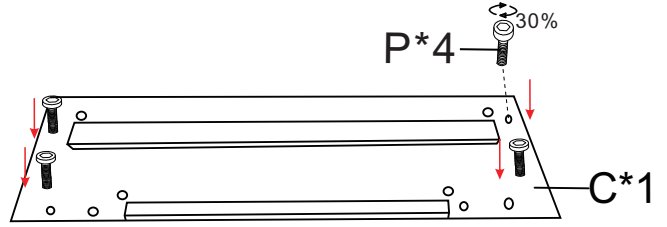

Screw tightening 30%

Back panel 2

- ③ Assemble the Back panel(C) with bolts(P).



Screw tightening 30%

Back panel 3

- ④ Assemble the Back panel(C) with bolts(P).

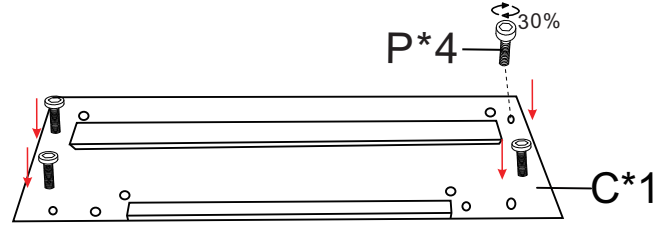

Screw tightening 30%

Back panel 4

- ⑤ Assemble the Front panel(D) with bolts(P).

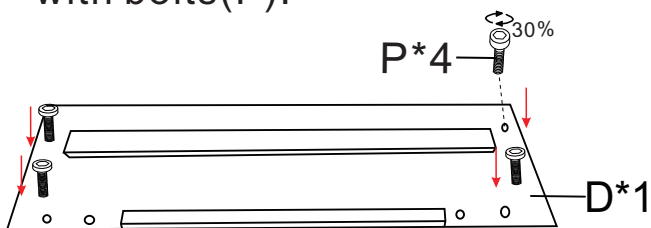

Screw tightening 30%

Front panel 1

- ⑥ Assemble the Front panel(D) with bolts(P).

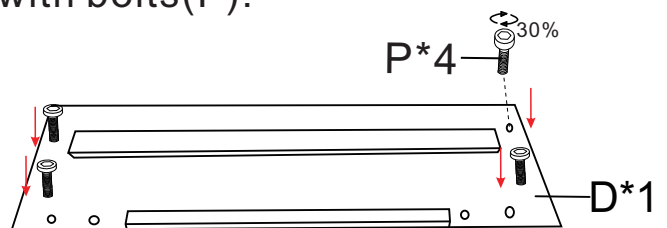

Screw tightening 30%

Front panel 2

STEP 4

- ⑦ Assemble the Front panel(D) with bolts(P).

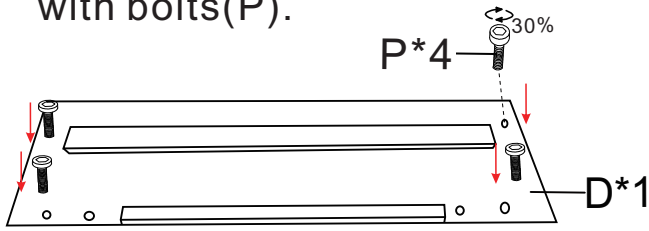

Screw tightening 30%
Front panel 3

- ⑧ Assemble the Front panel(D) with bolts(P).

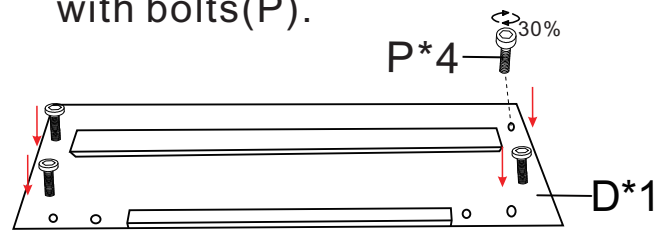

Screw tightening 30%
Front panel 4

- ⑨ Assemble the Left panel(E) and Right panel (F) to the Back panel(C).

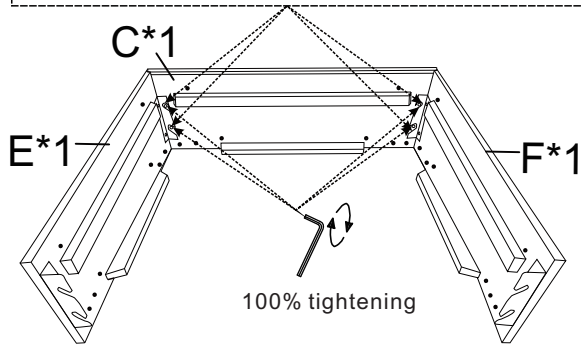
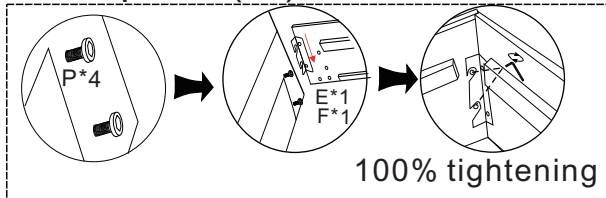

- ⑩ Assemble the Front panel(D) to the frame.

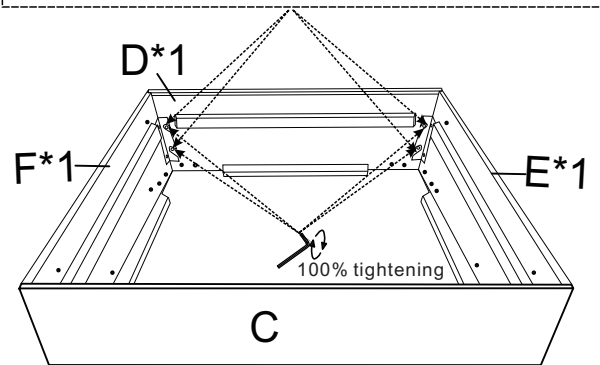
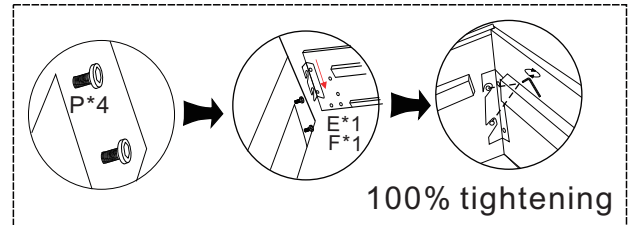

- ⑪ Assemble the Left panel(E) and Right panel (F) to the Back panel(C).

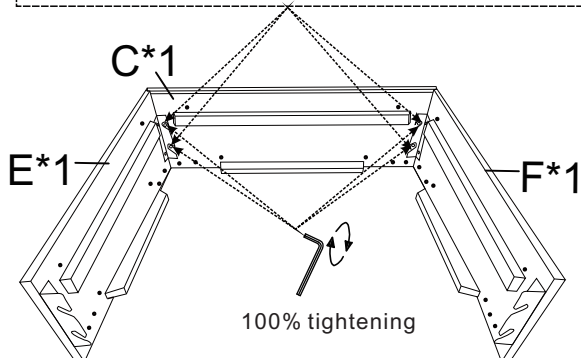
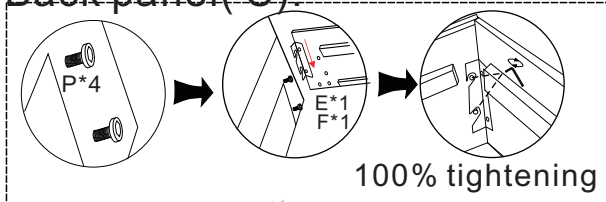

- ⑫ Assemble the Front panel(D) to the frame.

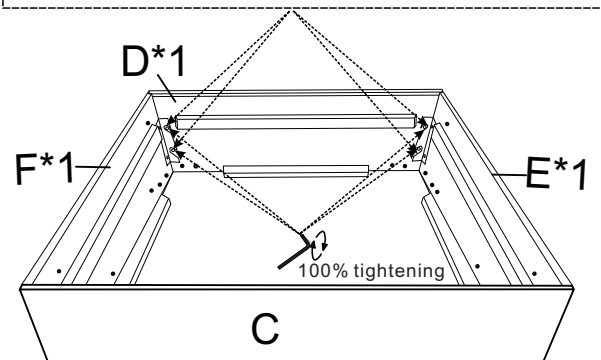
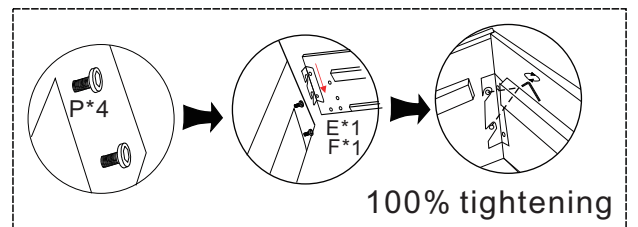

STEP 4

- ⑬ Assemble the Left panel(E) and Right panel (F) to the Back panel(C).

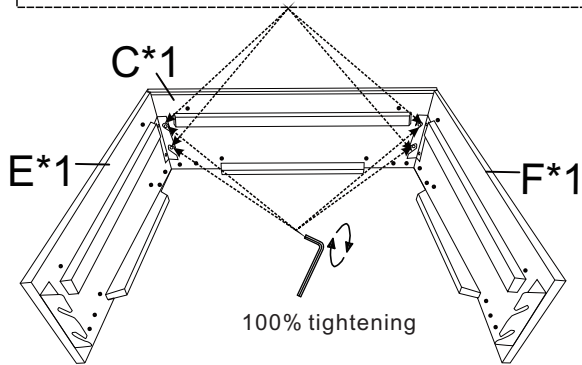
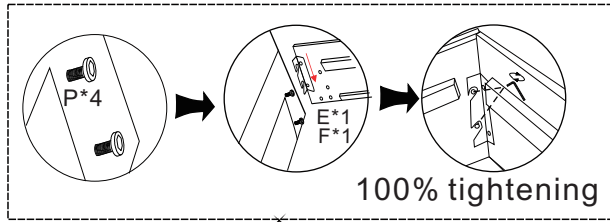

- ⑭ Assemble the Front panel(D) to the frame.

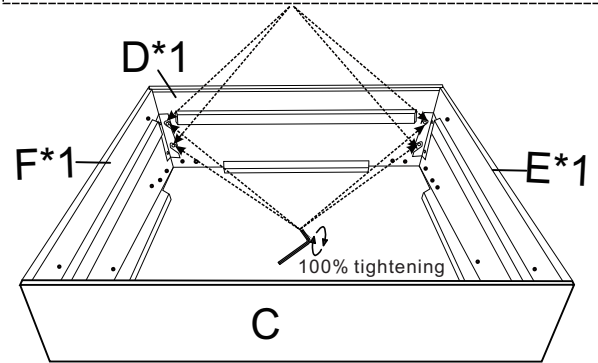
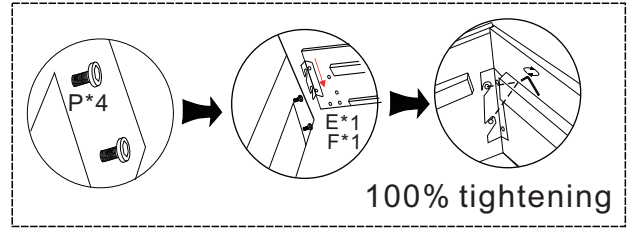

- ⑮ Assemble the Left panel(E) and Right panel (F) to the Back panel(C).

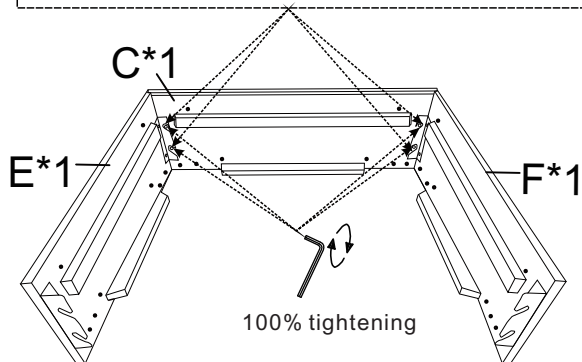
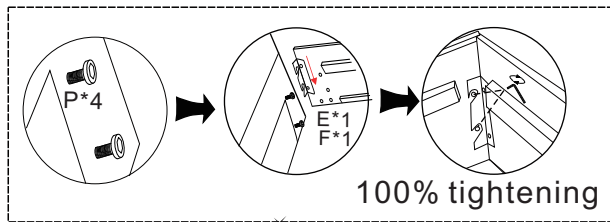

- ⑯ Assemble the Front panel(D) to the frame.

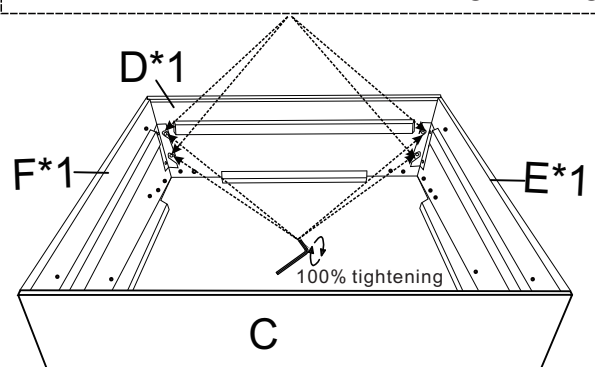
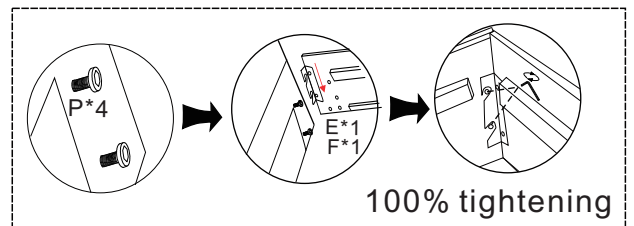

STEP 4

17 Assemble the Legs(N) into the seat frame with bolts (P).

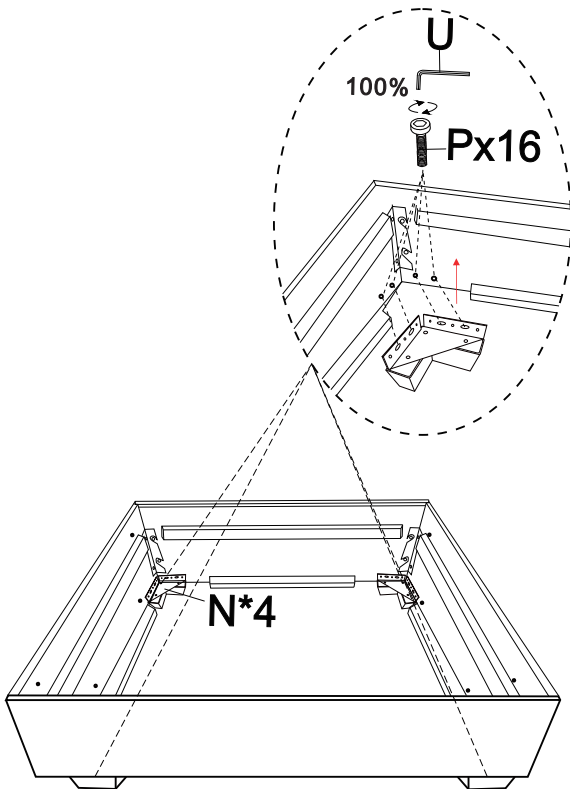

18 Assemble the Legs(N) into the seat frame with bolts (P).

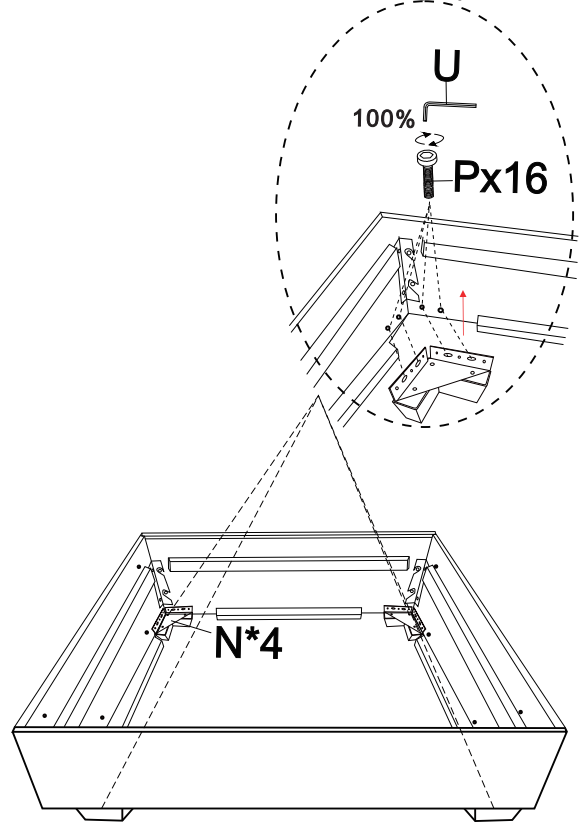

19 Assemble the Legs(N) into the seat frame with bolts (P).

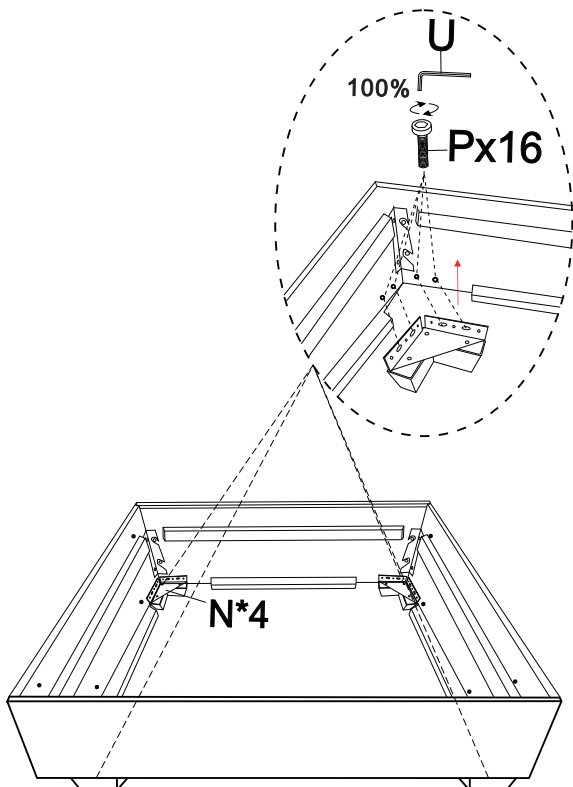

20 Assemble the Legs(N) into the seat frame with bolts (P).

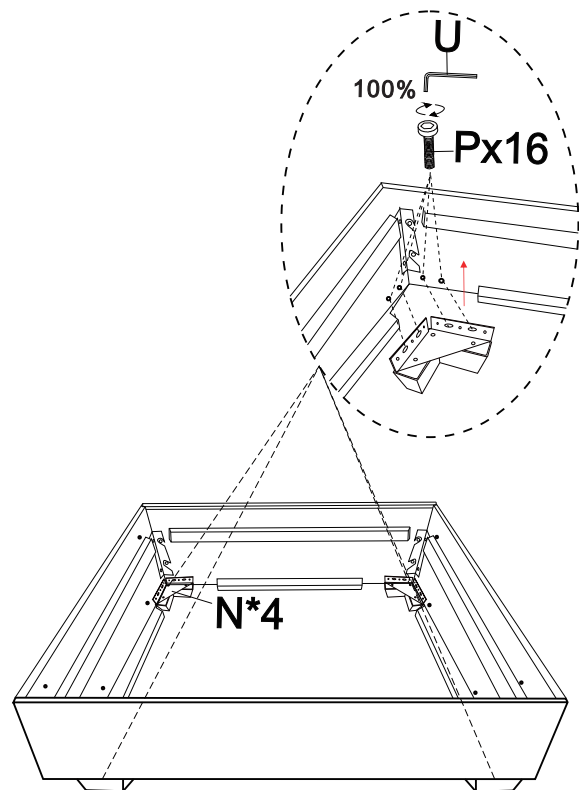

STEP 4

- 21 Assemble the Backrest(A) to the seat frame with washer(S)and Bolts(Q).

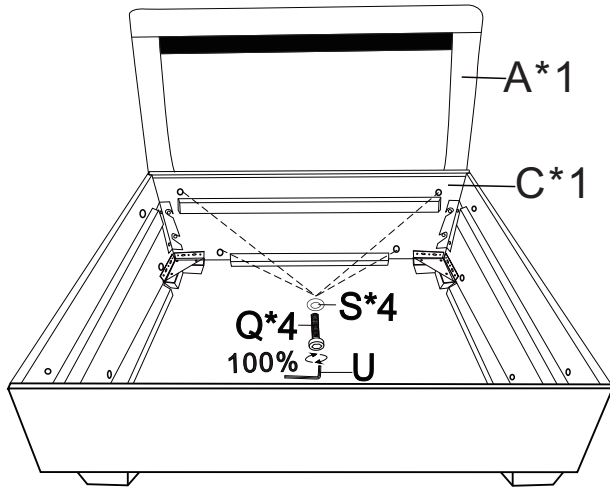

Backrest 1

- 22 Assemble the Backrest(A) to the seat frame with washer(S)and Bolts(Q).

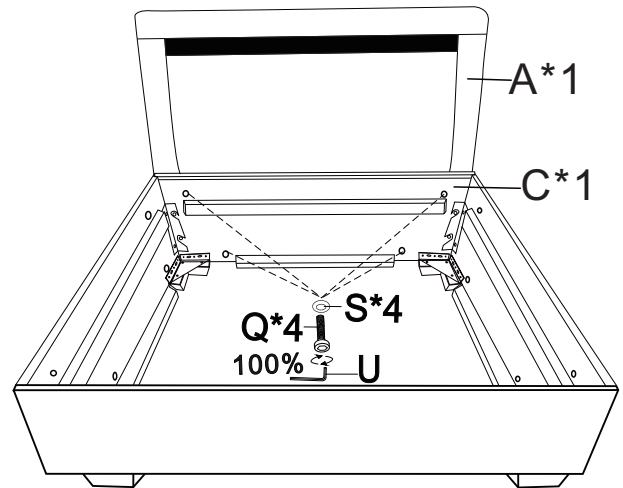

Backrest 2

- 23 Assemble the Backrest(A) to the seat frame with washer(S)and Bolts(Q).

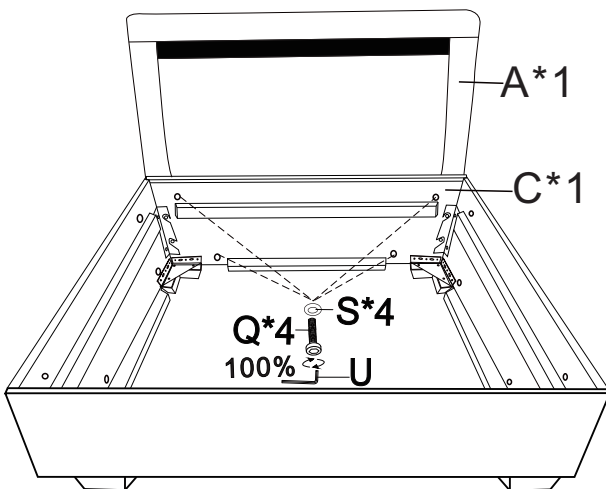

Backrest 3

- 24 Assemble the Backrest(A) to the seat frame with washer(S)and Bolts(Q).

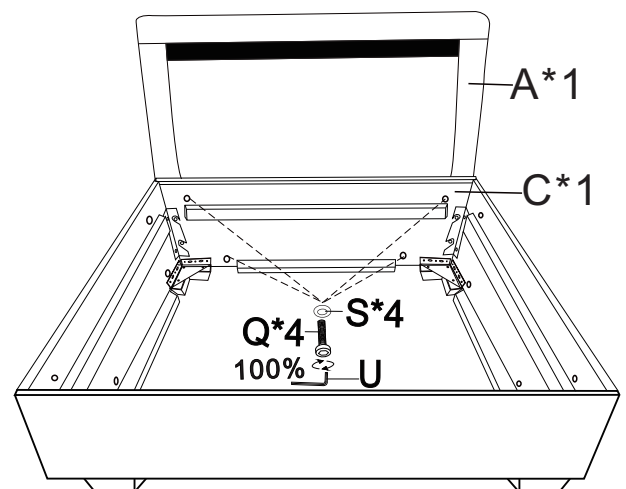

Backrest 4

STEP 4

- 25 Assemble the leg(O) to the Armrest(B).

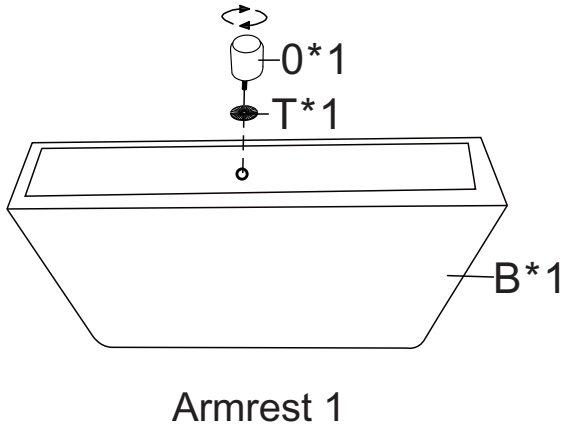

- 26 Assemble the Armrest(B) to the seat frame with washer(S) and Bolts(R).

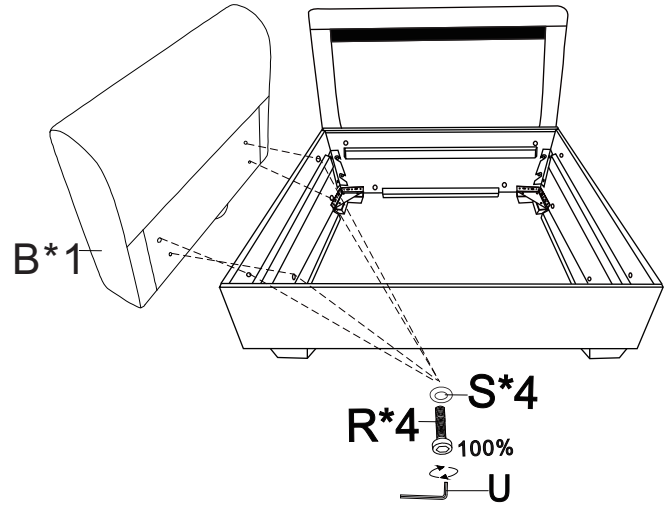

- 27 Assemble the leg(O) to the Armrest(B).

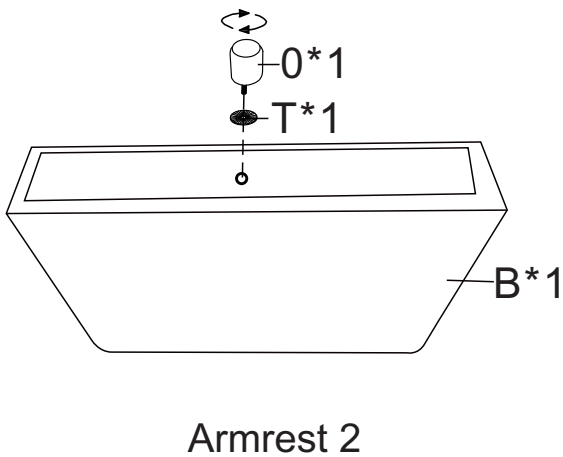

- 28 Assemble the Armrest(B) to the seat frame with washer(S) and Bolts(R).

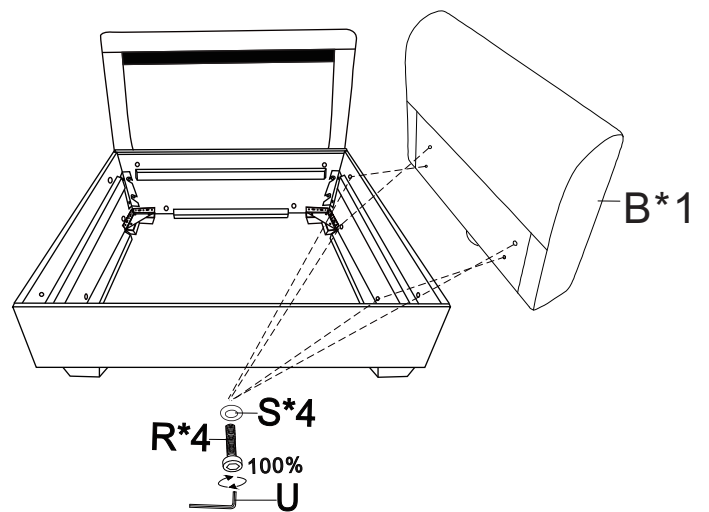

STEP 4

29 Insert the bottom plate(H) to the bottom of the seat frame.

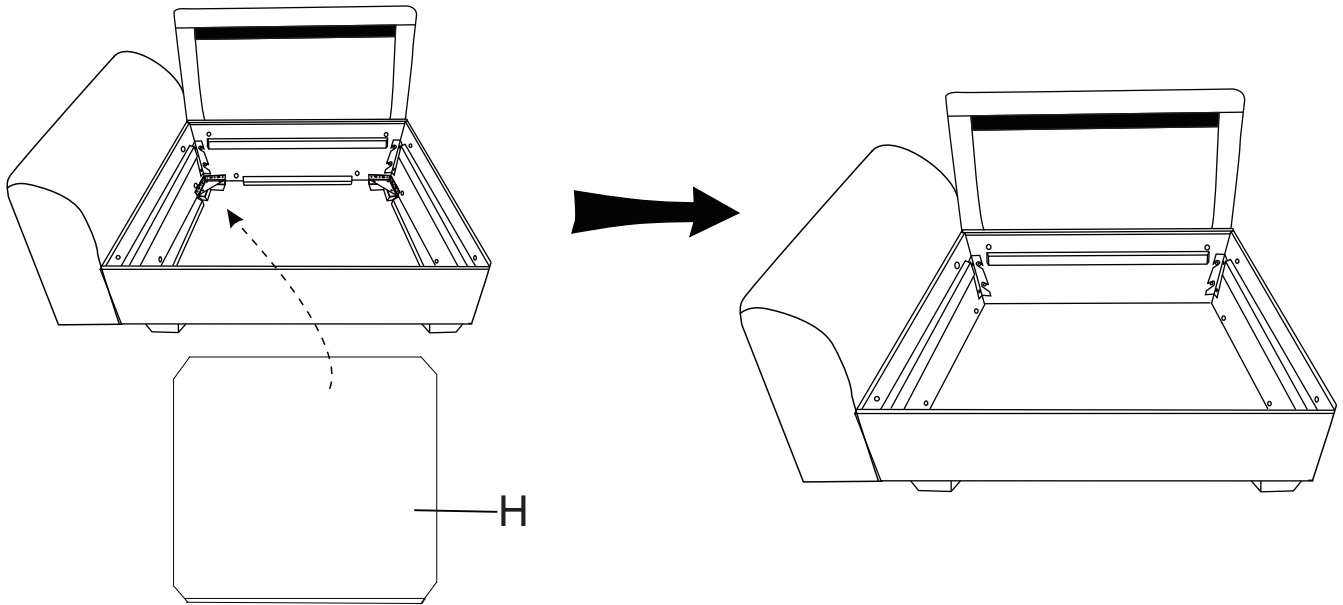

30 Insert the bottom plate(H) to the bottom of the seat frame.

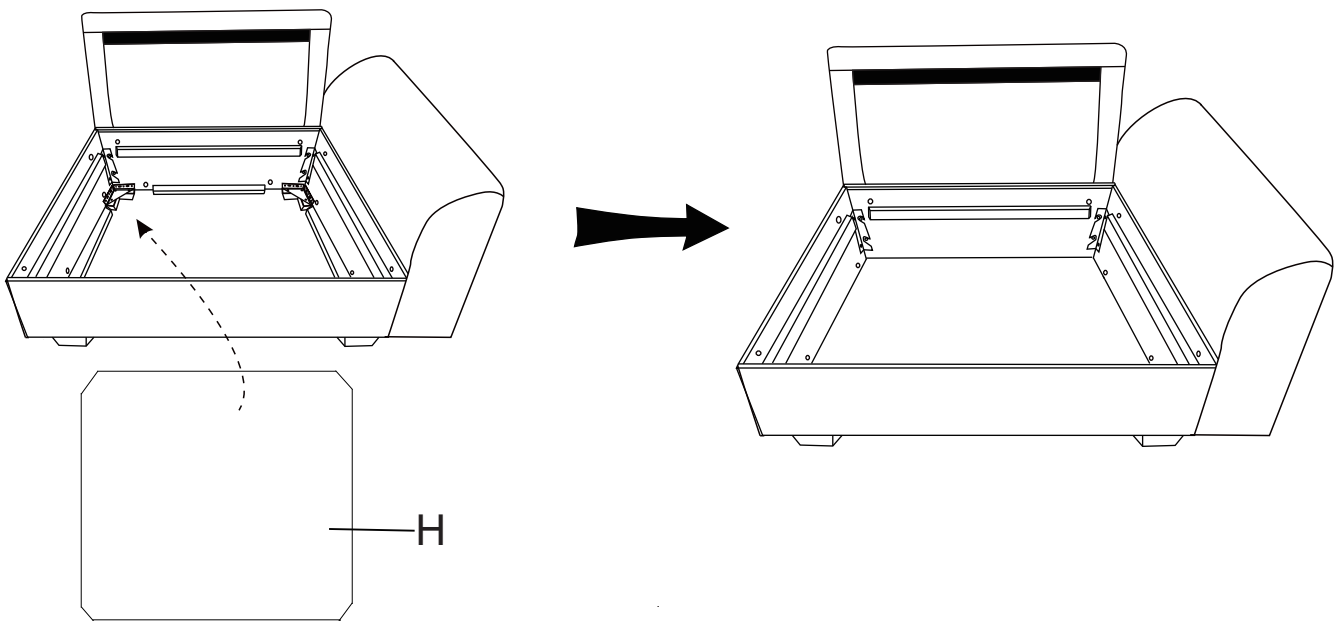

STEP 4

③1 Insert the bottom plate(H) to the bottom of the seat frame.

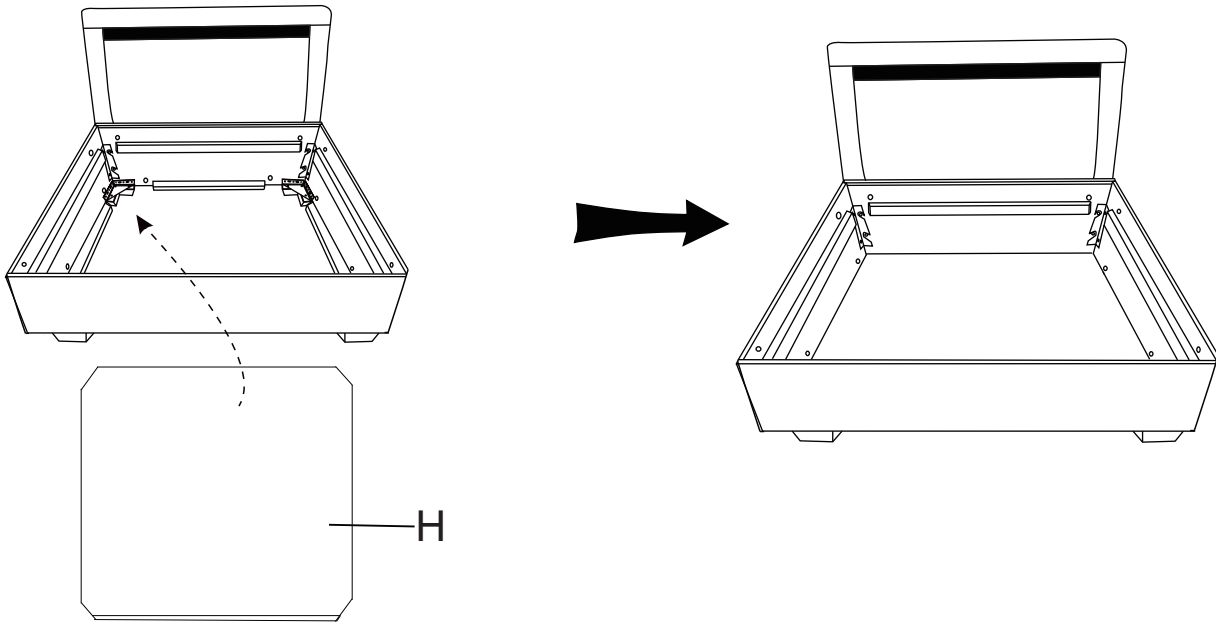

③2 Insert the bottom plate(H) to the bottom of the seat frame.

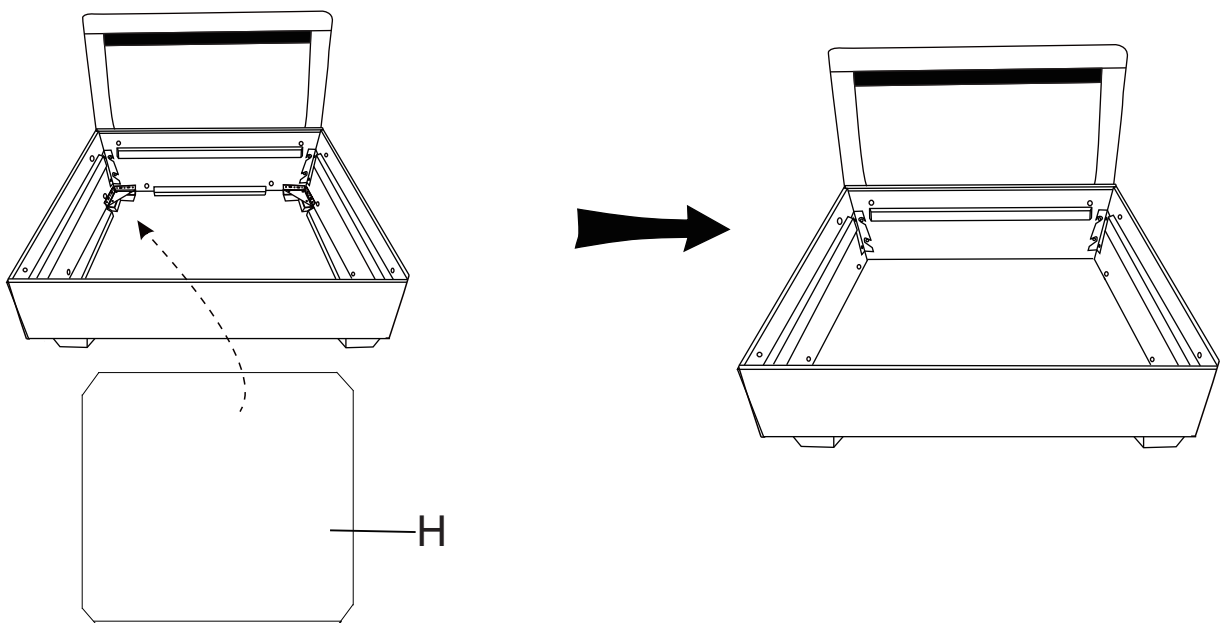

STEP 4

- 33 Insert the bottom plate(H) to the bottom of the seat frame
Butterfly nut (V).

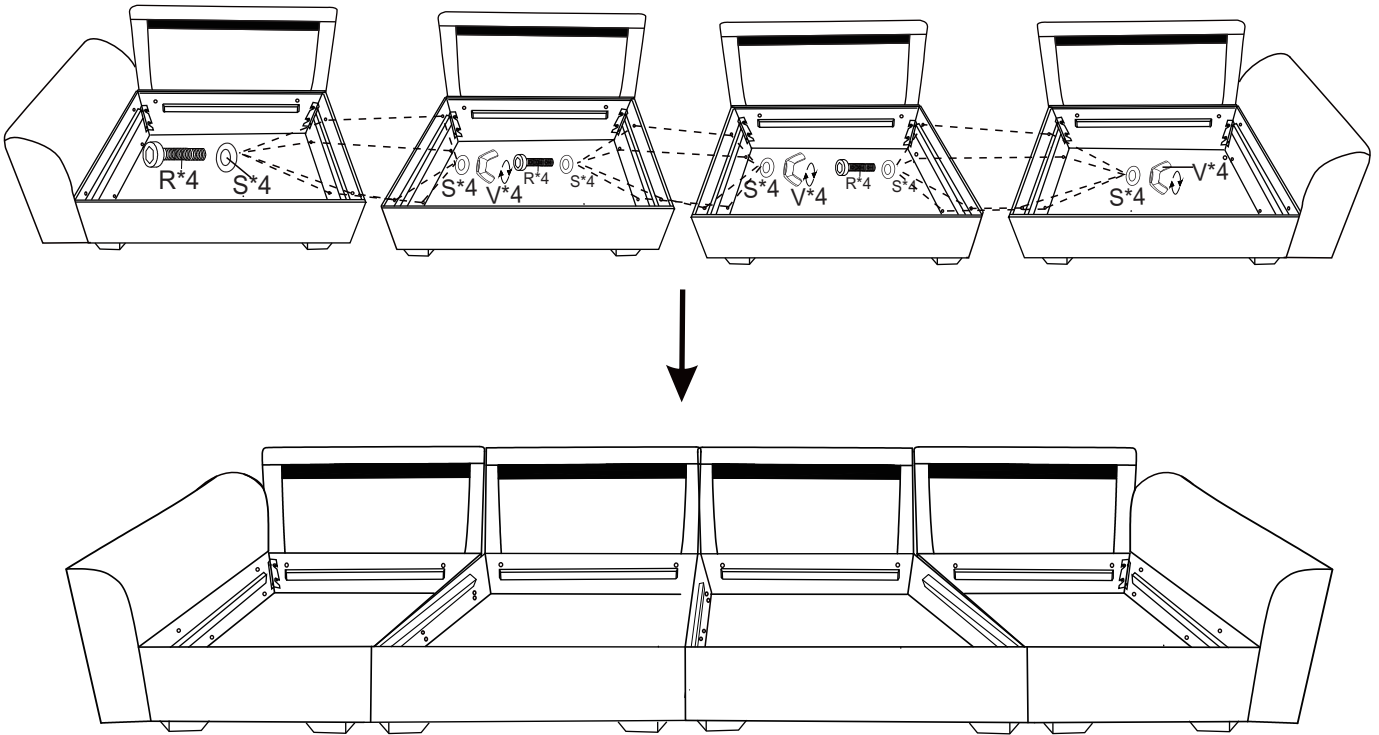

- 34 Put the upper cover plate(G) to the Sofa.

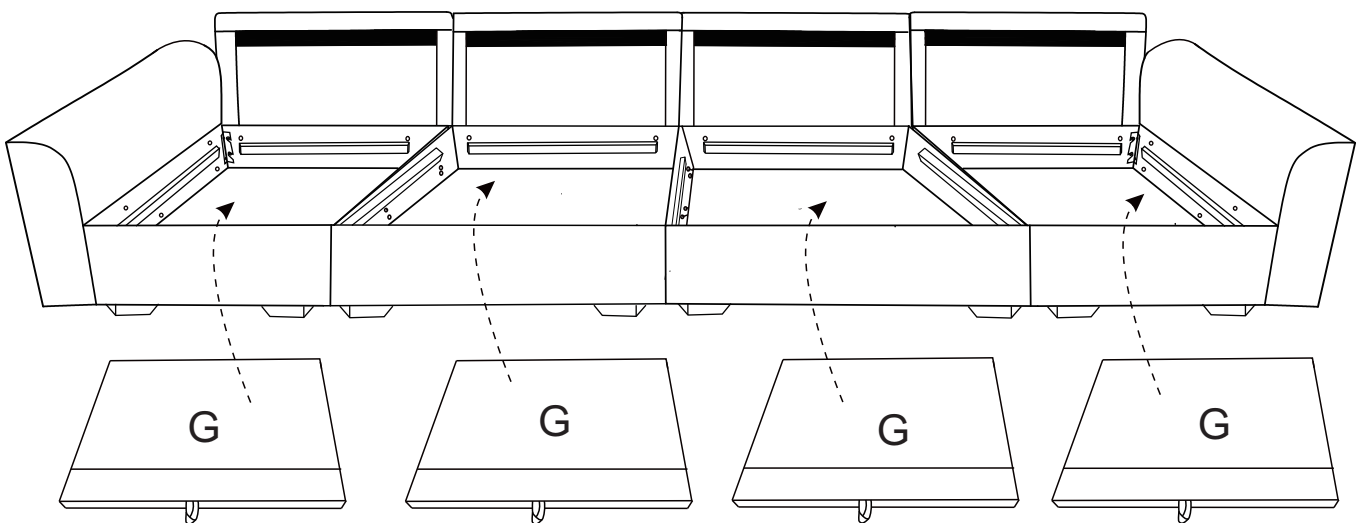

STEP 4

35 Put the Seat cushion(I)and Small back cushion (K)to the sofa.

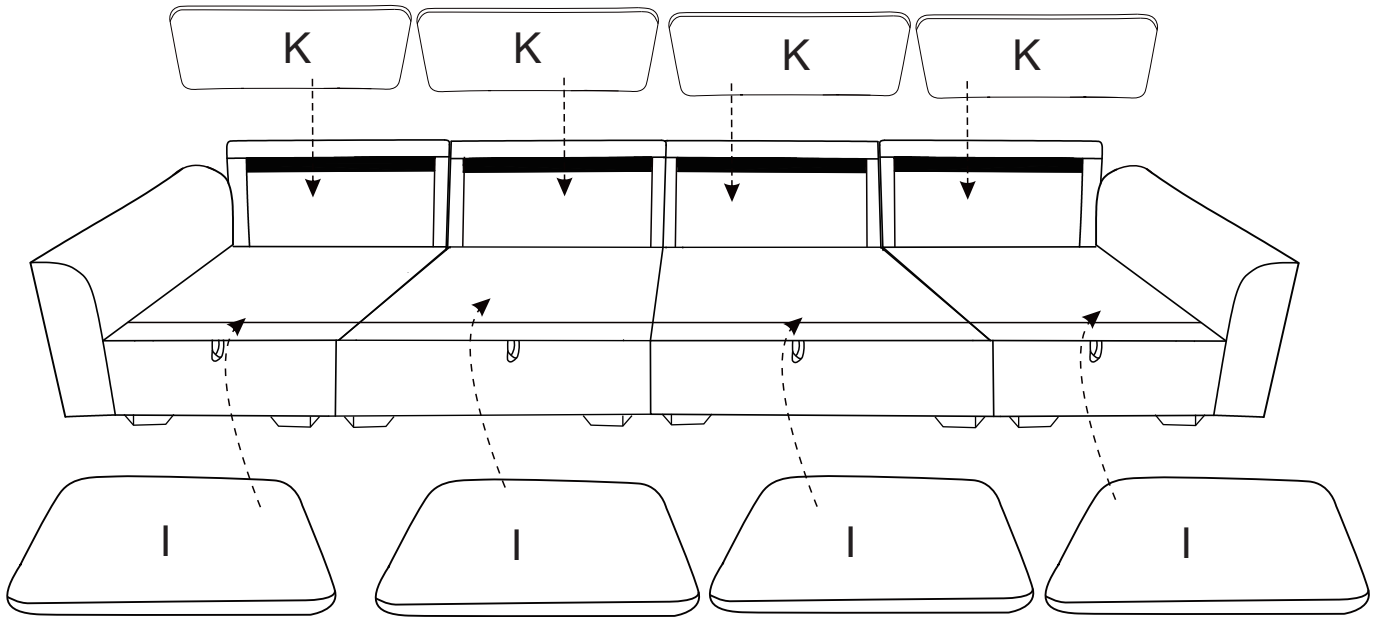

36 Put the Armrest pillow(J)and Big back cushion(L)on the sofa .

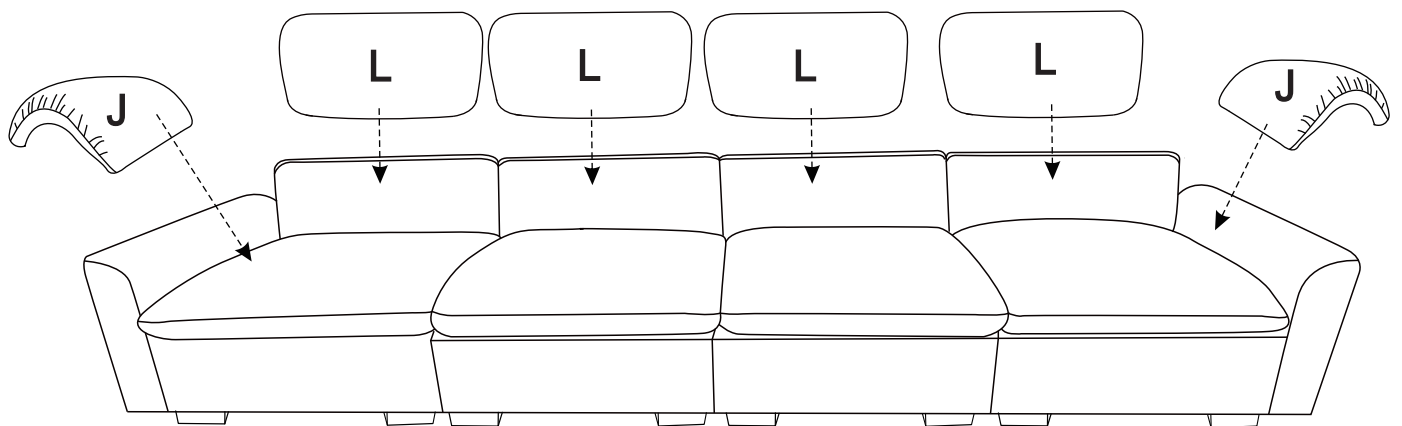

STEP 4

37 Put the Pillow(M) on sofa .

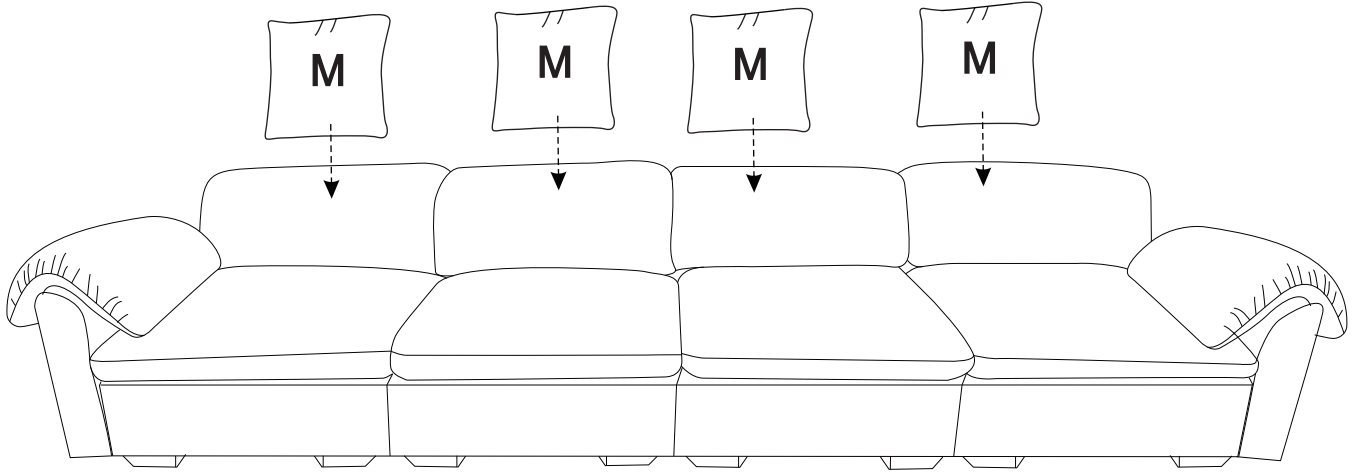

38 Completed :

