

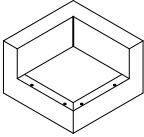

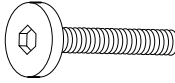



# ASSEMBLY INSTRUCTIONS

## REVERSIBLE CHAIR WITH ONE ARM

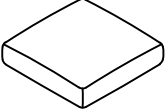
**!** The legs and hardware are stored in the bottom of the chair with one arm, please take them out for assembly.  
 Note: Do not use power tools for assembly. Power tools increase the risk of over tightening which leads to splitting or cracking the wood.

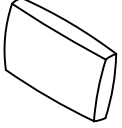
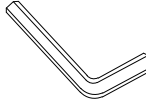
COMPONENT LIST				HARDWARE LIST			
PART	DRAWING	DESCRIPTION	QTY	PART	DRAWING	DESCRIPTION	QTY
A		Seat	1 PC	1		Bolt Ø5/16"x2 -1/2"	4 PCS
B		Plastic Leg 4-1/8"x4-1/8"x2-1/3"	4 PCS	2		Spring Washer Ø5/16"	4 PCS
C		Seat Cushion	1 PC	3		Flat Washer Ø5/16"x3/4"	4 PCS
D		Back Cushion	1 PC	4		Allen KeyM4 2-1/3"	1 PC
E		Pillow 20"x20"	1 PC	5		U Shape Metal Connector Ø3/16" x 8-2/3" x 3-5/32"	2 PCS

# ASSEMBLY INSTRUCTIONS

## REVERSIBLE CHAIR WITH ONE ARM

### STEP 1:

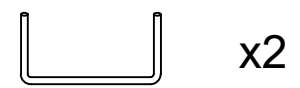
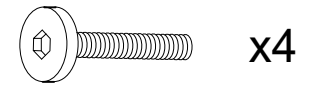
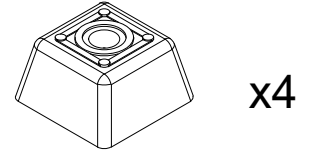
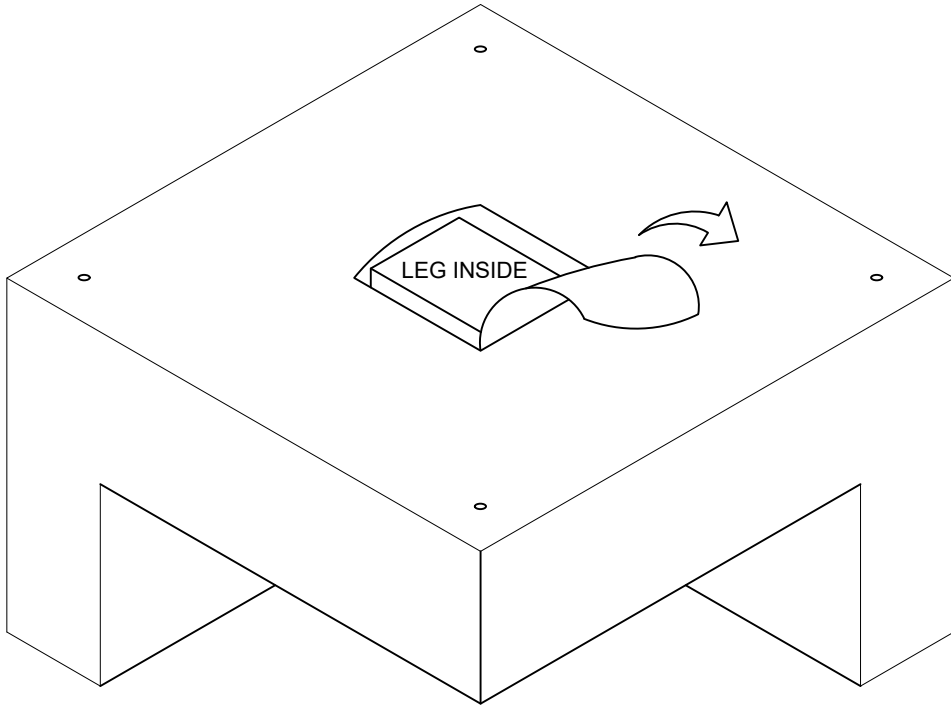

### STEP 2:

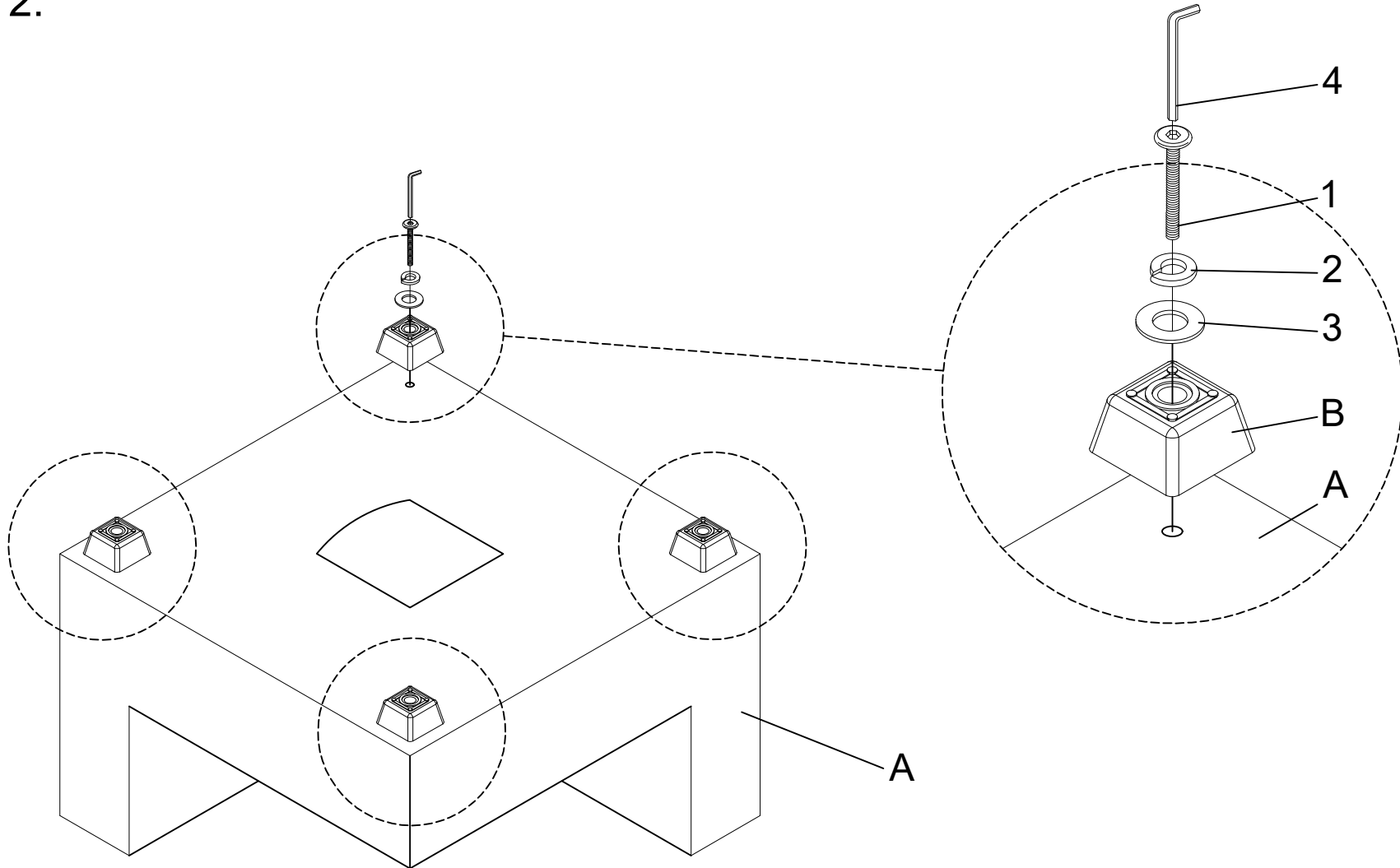

# ASSEMBLY INSTRUCTIONS

## REVERSIBLE CHAIR WITH ONE ARM

STEP 3A:

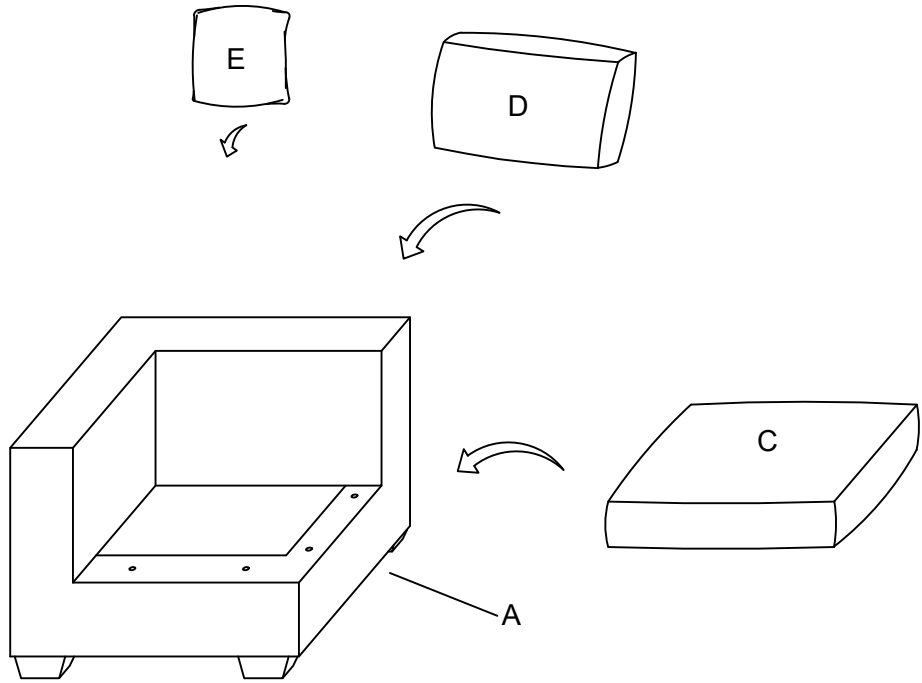

STEP 3B:

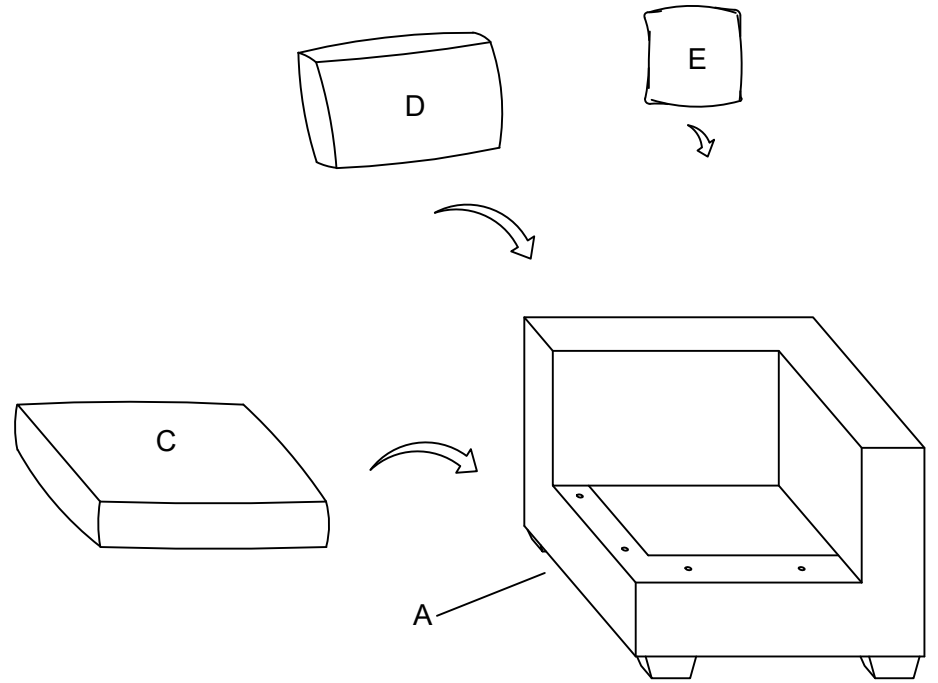

COMPLETED. #A

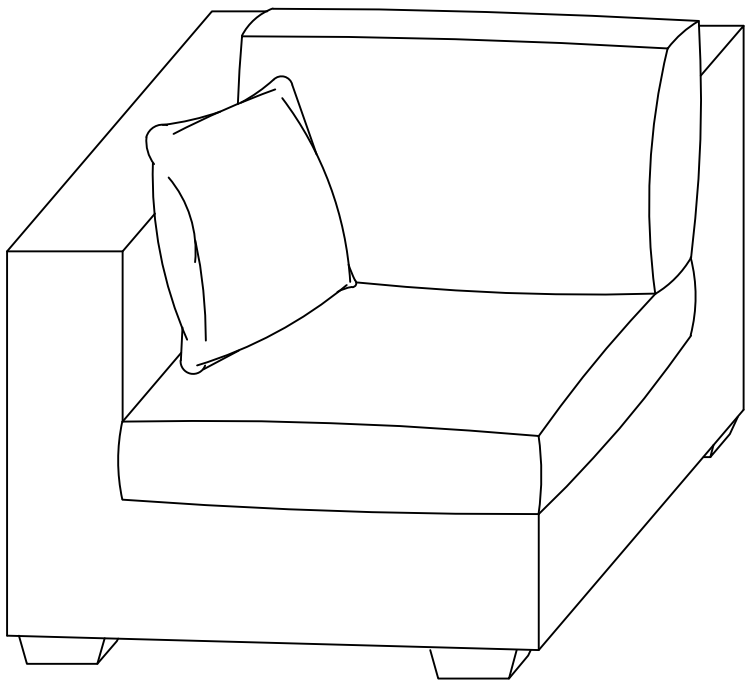

COMPLETED. #B

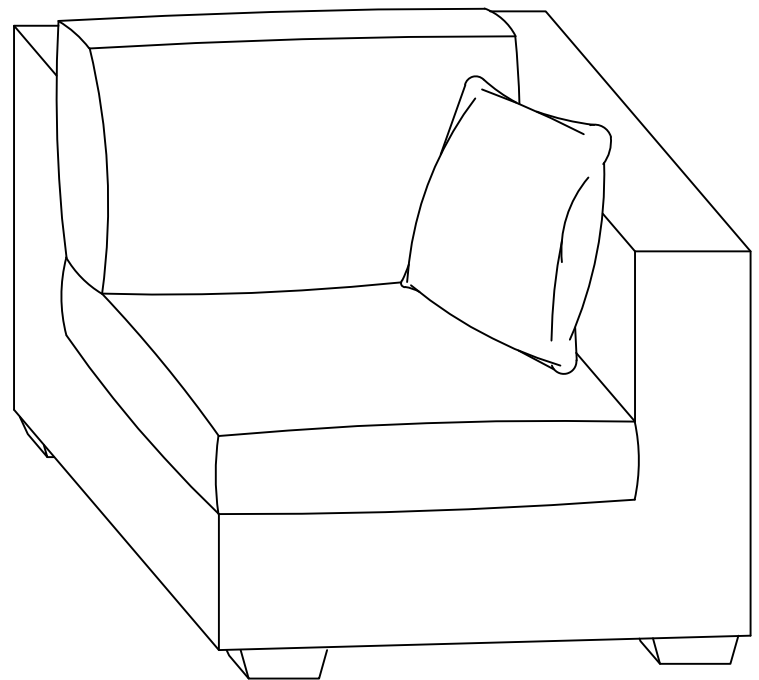

# ASSEMBLY INSTRUCTIONS

## REVERSIBLE CHAIR WITH ONE ARM

### SECTIONAL ASSEMBLY

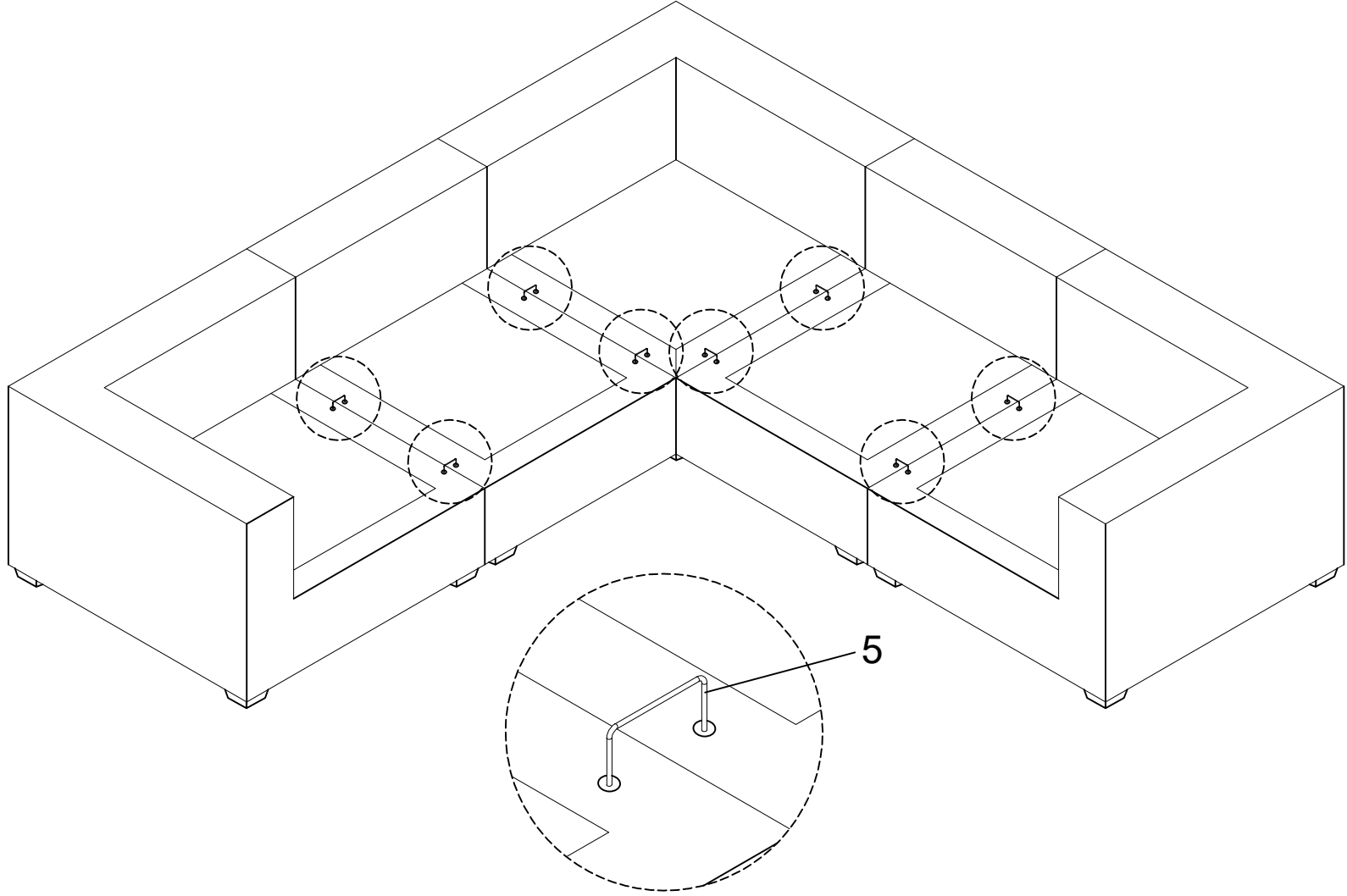

### COMPLETED.

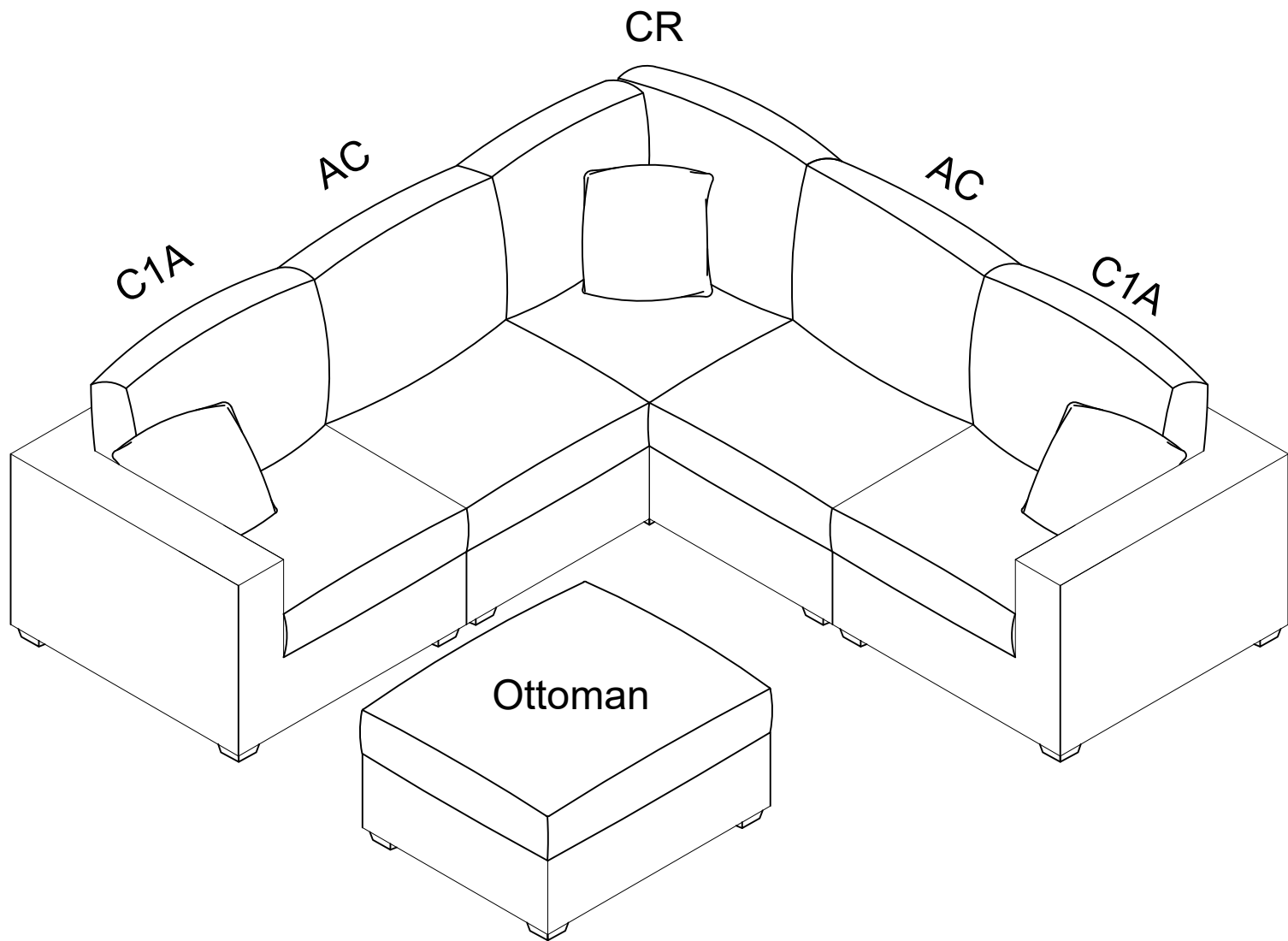

#### Care Instructions for Chenille Furniture:

In order to maintain the original appearance of your chenille furniture, please follow the simple care procedures below:

- Avoid exposing furniture directly to sunlight or heating and air conditioning outlets. Sunlight and/or exposure to heating and air conditioning outlets will fade/damage chenille.
- Vacuum or wipe with a soft cloth to remove dust.
- Hardware may loosen over time. Periodically check to make sure all connections are tight. Re-tighten if necessary.

For item use on wooden floor, hard surfaces or carpets, it is recommended to install protective pads under all legs and supports to prevent damage/scratches and discoloration.

# ASSEMBLY INSTRUCTIONS

## CORNER SEAT

**!** The legs and hardware are stored in the bottom of the corner seat, please take them out for assembly.  
 Note: Do not use power tools for assembly. Power tools increase the risk of over tightening which leads to splitting or cracking the wood.

COMPONENT LIST			
PART	DRAWING	DESCRIPTION	QTY
A		Seat	1 PC
B		Plastic Leg 4-1/8"x4-1/8"x2-1/3"	4 PCS
C		Seat Cushion	1 PC
D		Big Back Cushion	1 PC
E		Small Back Cushion	1 PC
F		Pillow 20"x20"	1 PC

HARDWARE LIST			
PART	DRAWING	DESCRIPTION	QTY
1		Bolt Ø5/16"x2 -1/2"	4 PCS
2		Spring Washer Ø5/16"	4 PCS
3		Flat Washer Ø5/16"x3/4"	4 PCS
4		Allen Key M4 2-1/3"	1 PC
5		U Shape Metal Connector Ø3/16" x 8-2/3" x 3-5/32"	2 PCS

### STEP 1:

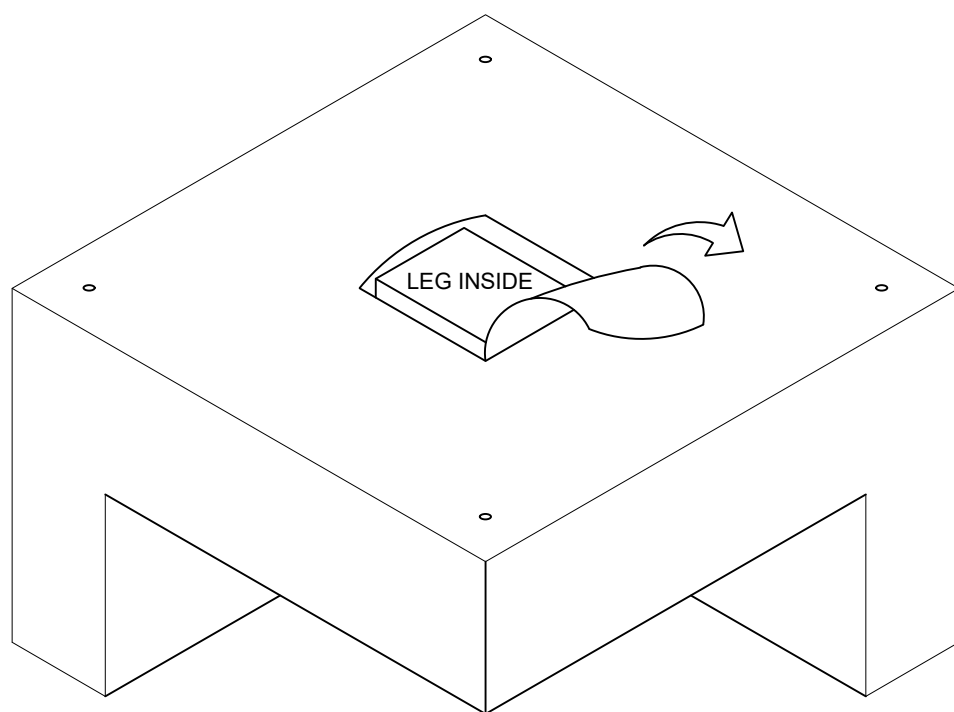

- x4
- x4
- x4
- x4
- x1
- x2

# ASSEMBLY INSTRUCTIONS

## CORNER SEAT

STEP 2:

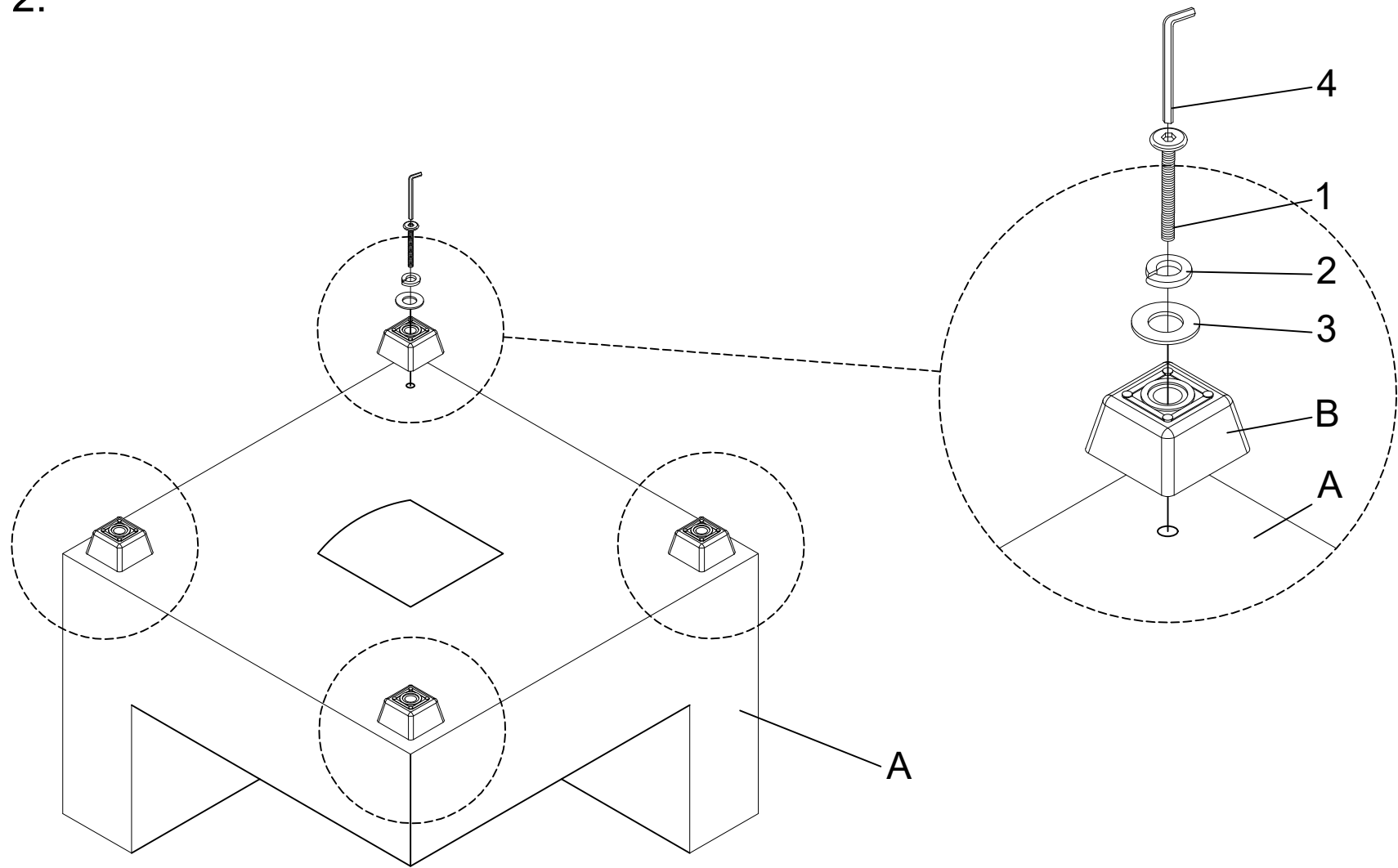

STEP 3:

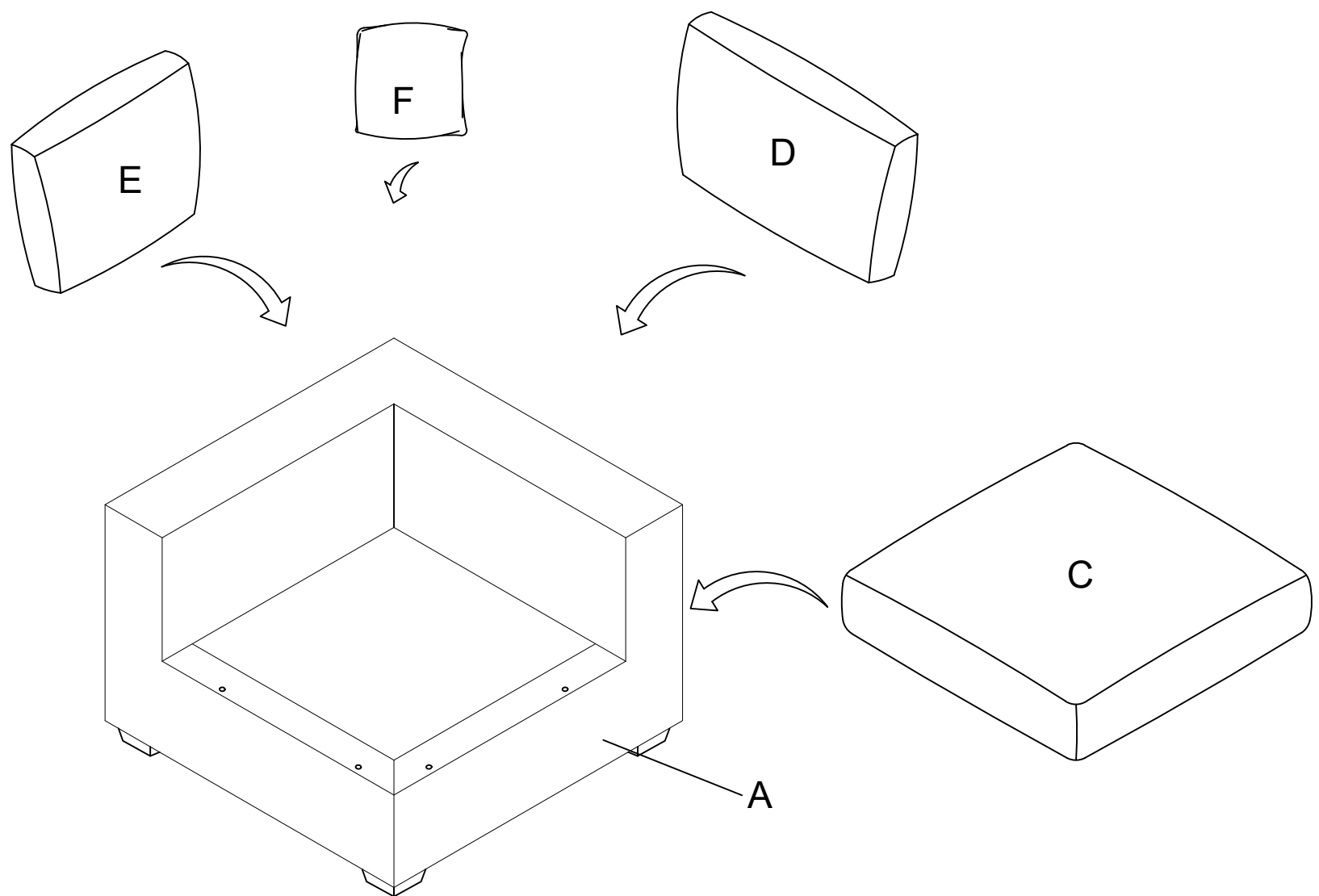

# ASSEMBLY INSTRUCTIONS

## CORNER SEAT

COMPLETED.

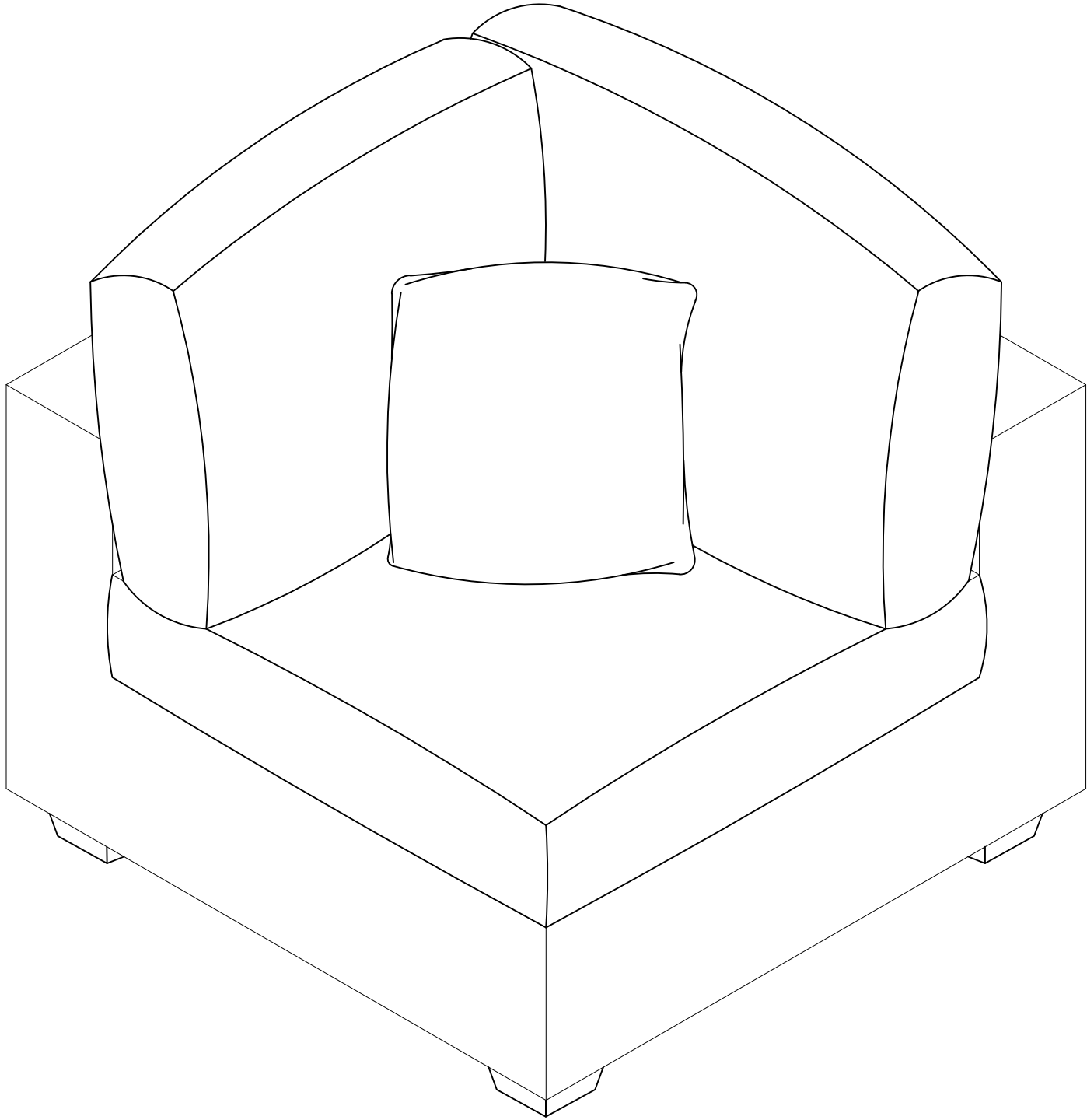

# ASSEMBLY INSTRUCTIONS

## CORNER SEAT

### SECTIONAL ASSEMBLY

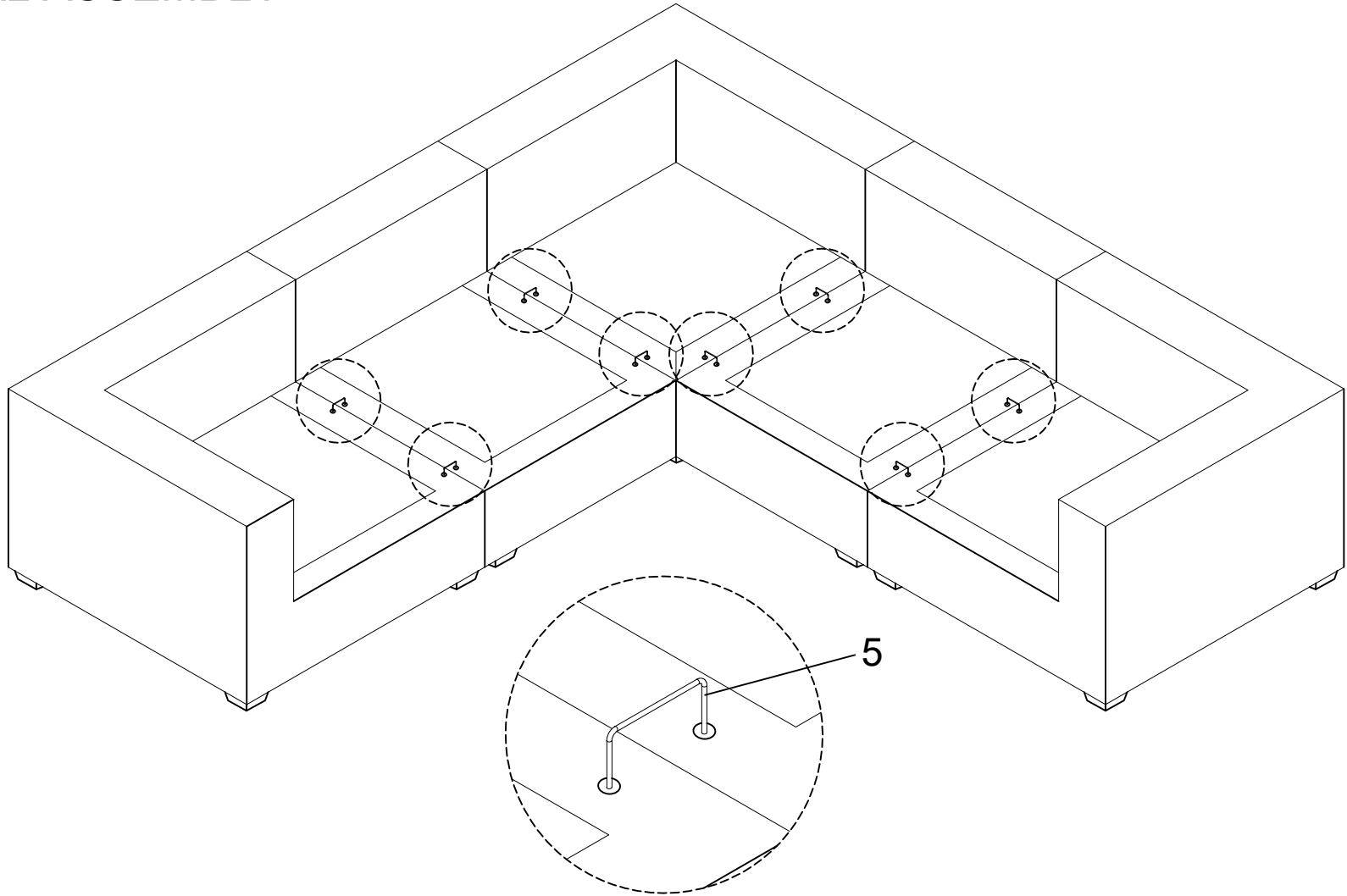

### COMPLETED.

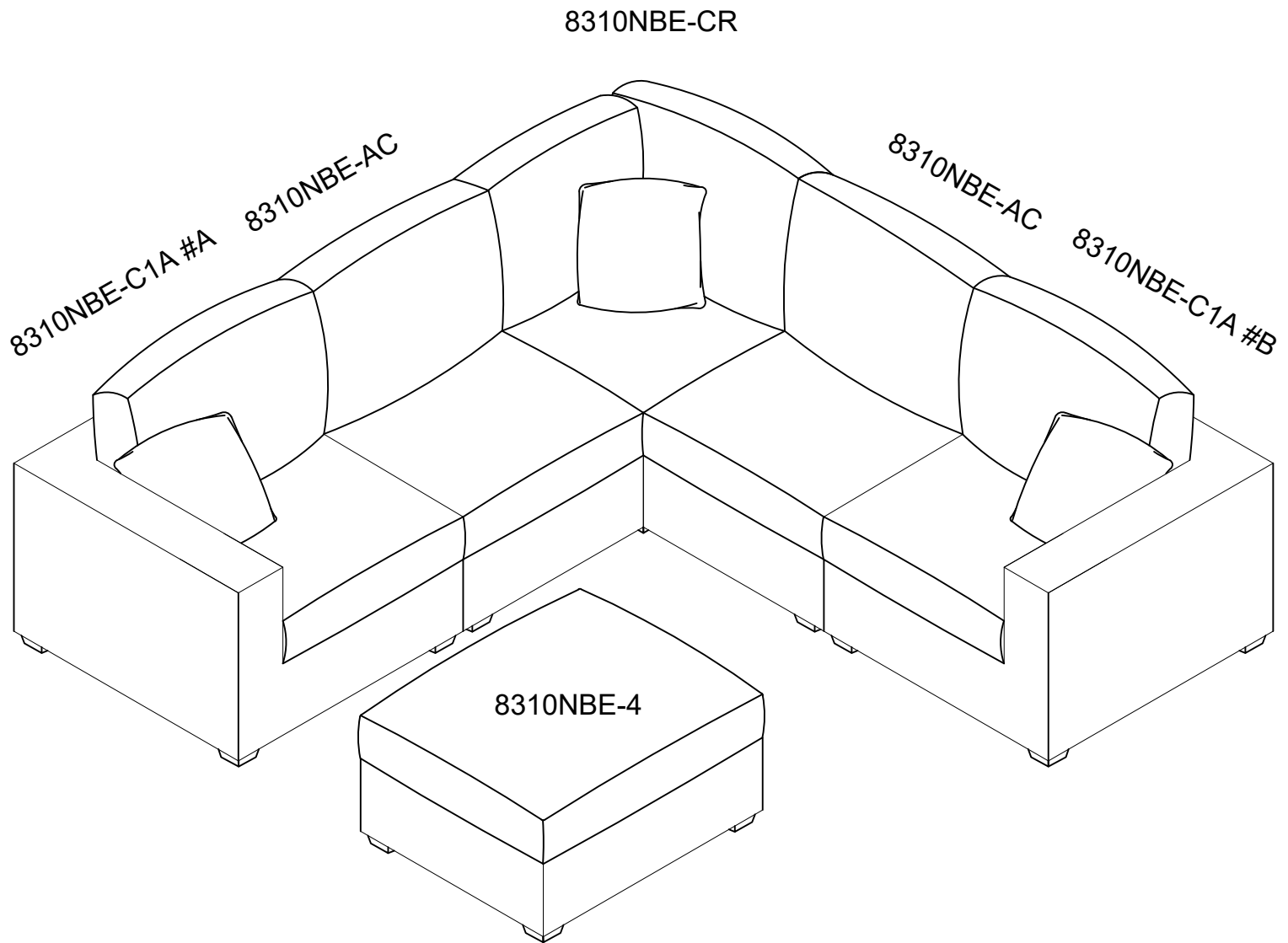

#### Care Instructions for Chenille Furniture:

In order to maintain the original appearance of your chenille furniture, please follow the simple care procedures below:

- Avoid exposing furniture directly to sunlight or heating and air conditioning outlets. Sunlight and/or exposure to heating and air conditioning outlets will fade/damage chenille.
- Vacuum or wipe with a soft cloth to remove dust.
- Hardware may loosen over time. Periodically check to make sure all connections are tight. Re-tighten if necessary.







For item use on wooden floor, hard surfaces or carpets, it is recommended to install protective pads under all legs and supports to prevent damage/scratches and discoloration.

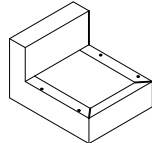
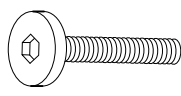
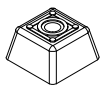

# ASSEMBLY INSTRUCTIONS

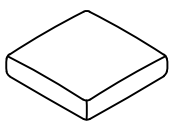

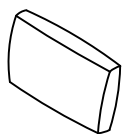
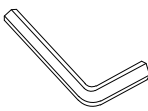

## ARMLSS CHAIR

**!** The legs and hardware are stored in the bottom of the armless chair, please take them out for assembly.  
 Note: Do not use power tools for assembly. Power tools increase the risk of over tightening which leads to splitting or cracking the wood.

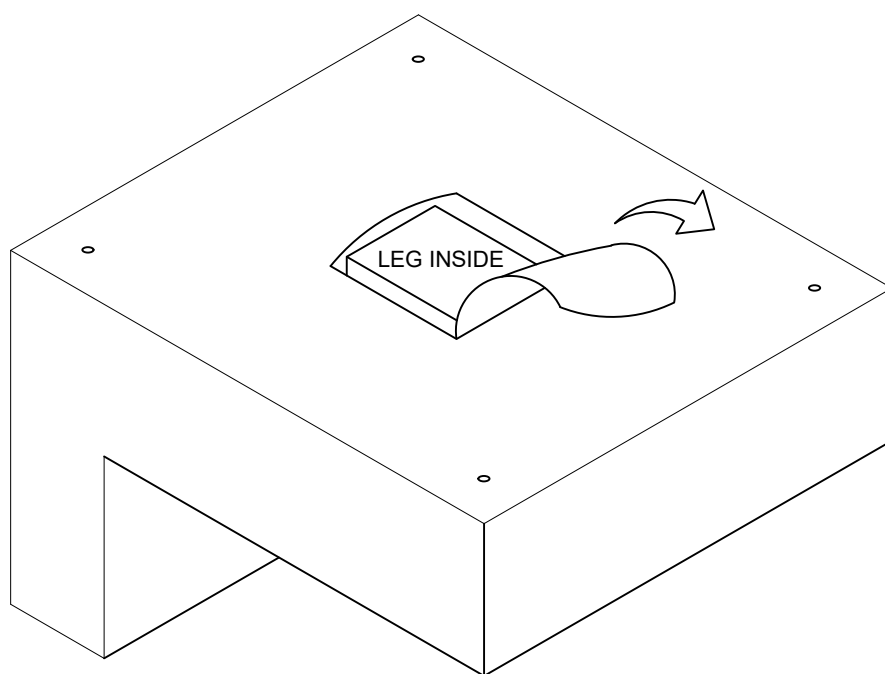
COMPONENT LIST				HARDWARE LIST			
PART	DRAWING	DESCRIPTION	QTY	PART	DRAWING	DESCRIPTION	QTY
A		Seat	1 PC	1		Bolt Ø5/16"x2 -1/2"	4 PCS
B		Plastic Leg 4-1/8"x4-1/8"x2-1/3"	4 PCS	2		Spring Washer Ø5/16"	4 PCS
C		Seat Cushion	1 PC	3		Flat Washer Ø5/16"x3/4"	4 PCS
D		Back Cushion	1 PC	4		Allen KeyM4 2-1/3"	1 PC
				5		U Shape Metal Connector Ø3/16" x 8-2/3" x 3-5/32"	2 PCS

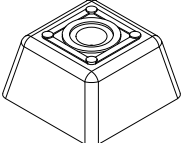
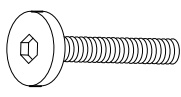
### STEP 1:

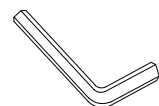

-  x4
-  x4
-  x4
-  x4
-  x1
-  x2

# ASSEMBLY INSTRUCTIONS

## ARMLESS CHAIR

### STEP 2:

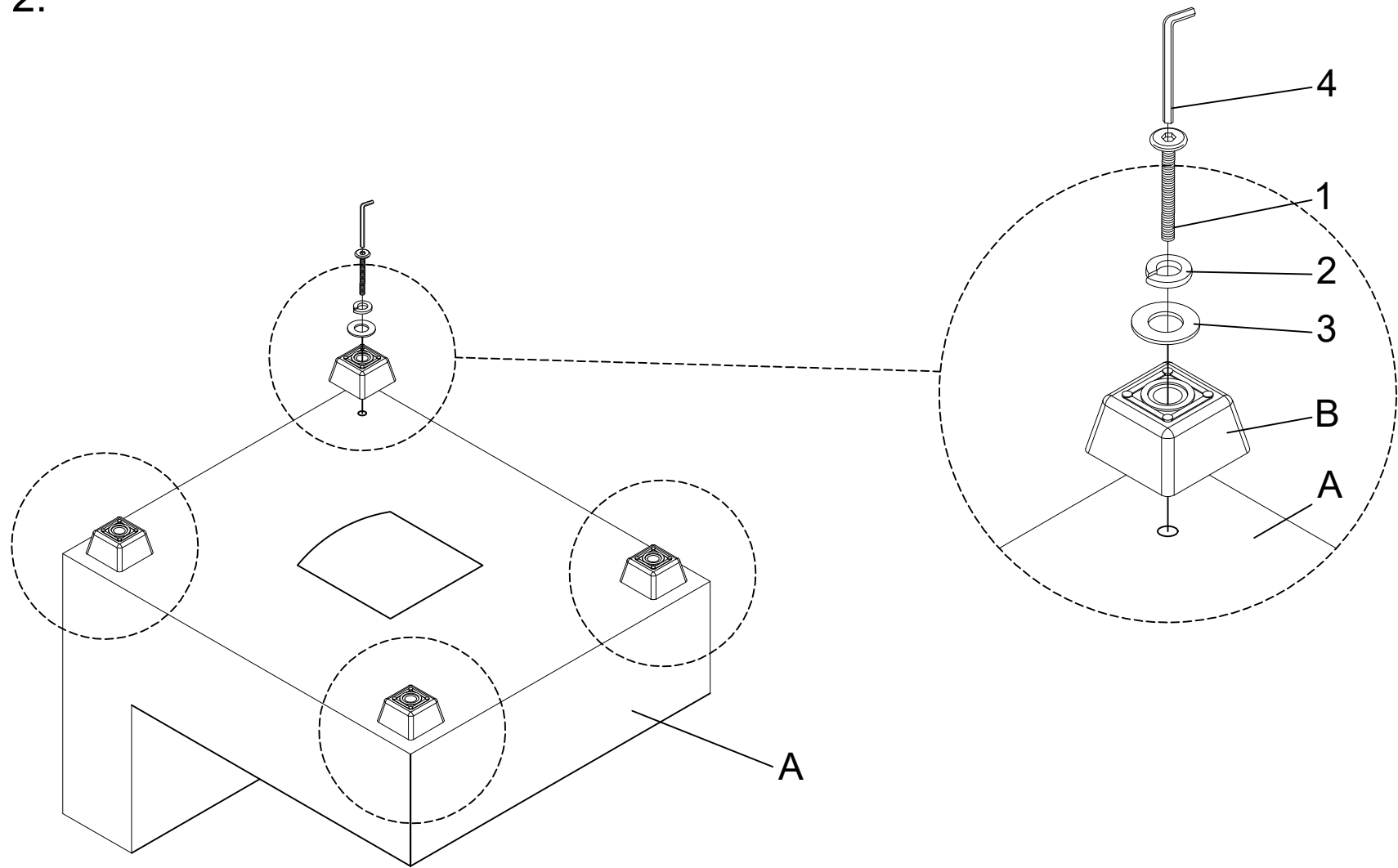

### STEP 3:

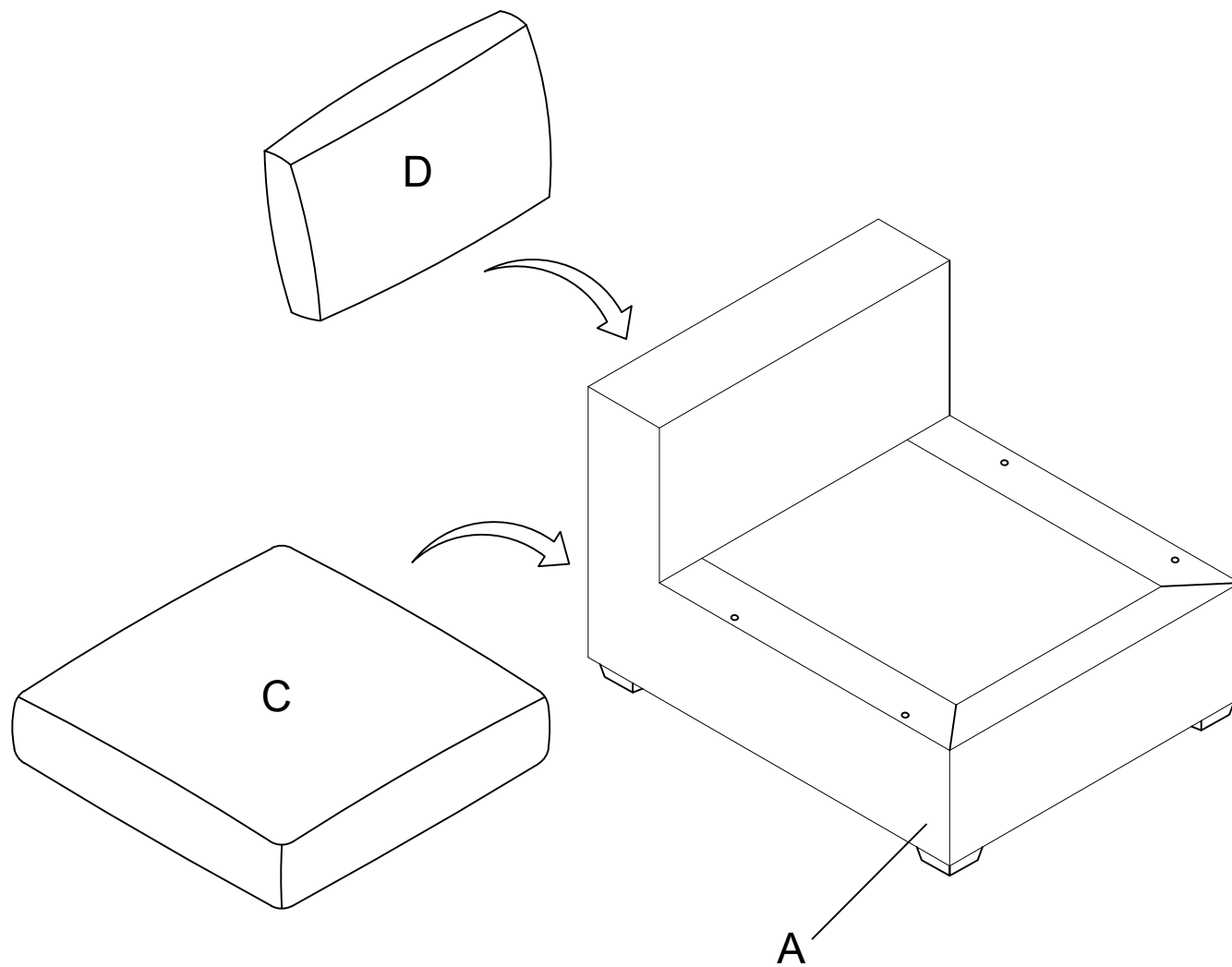

# ASSEMBLY INSTRUCTIONS

## ARMLESS CHAIR

COMPLETED.

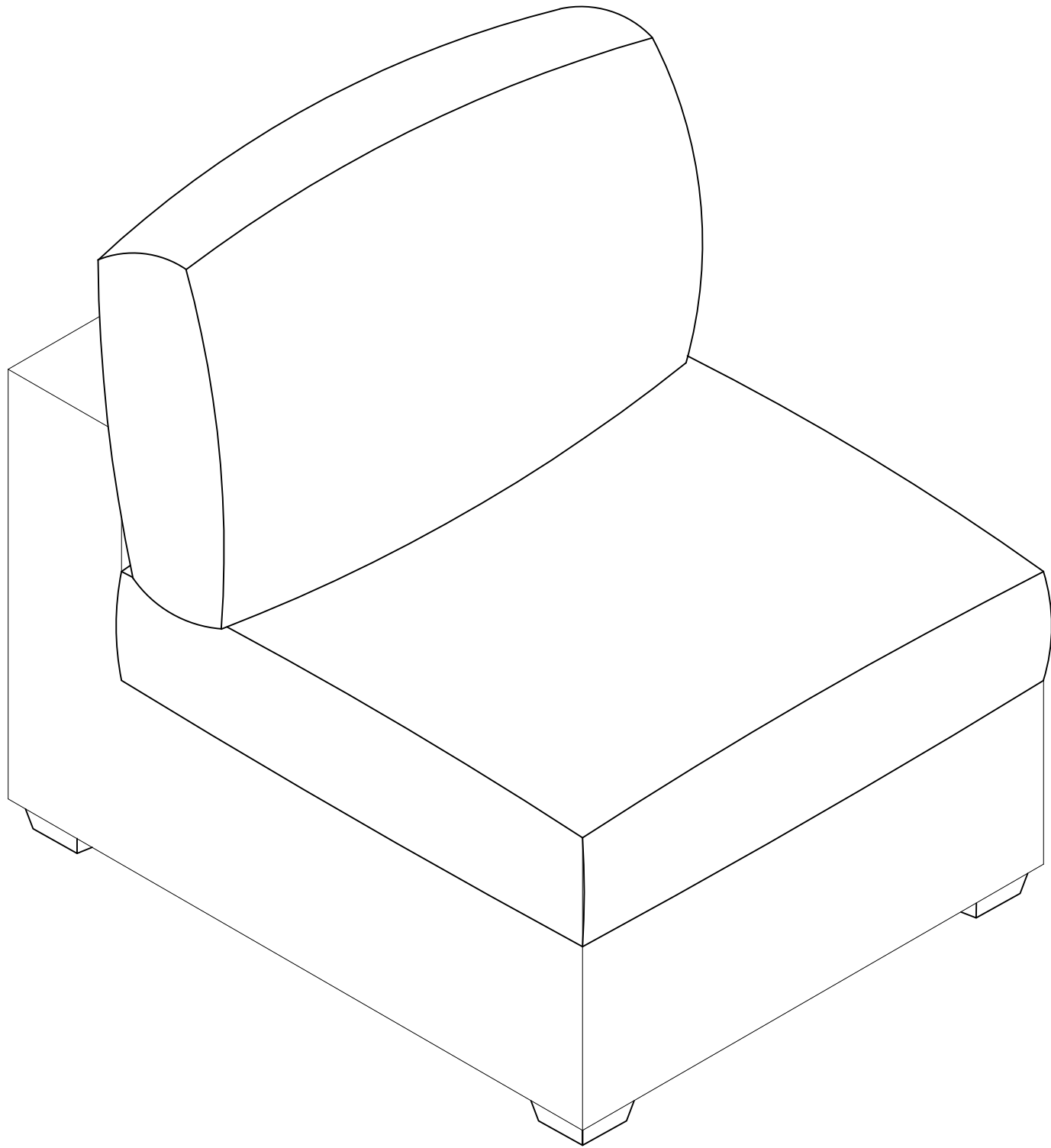

# ASSEMBLY INSTRUCTIONS

## ARMLESS CHAIR

### SECTIONAL ASSEMBLY

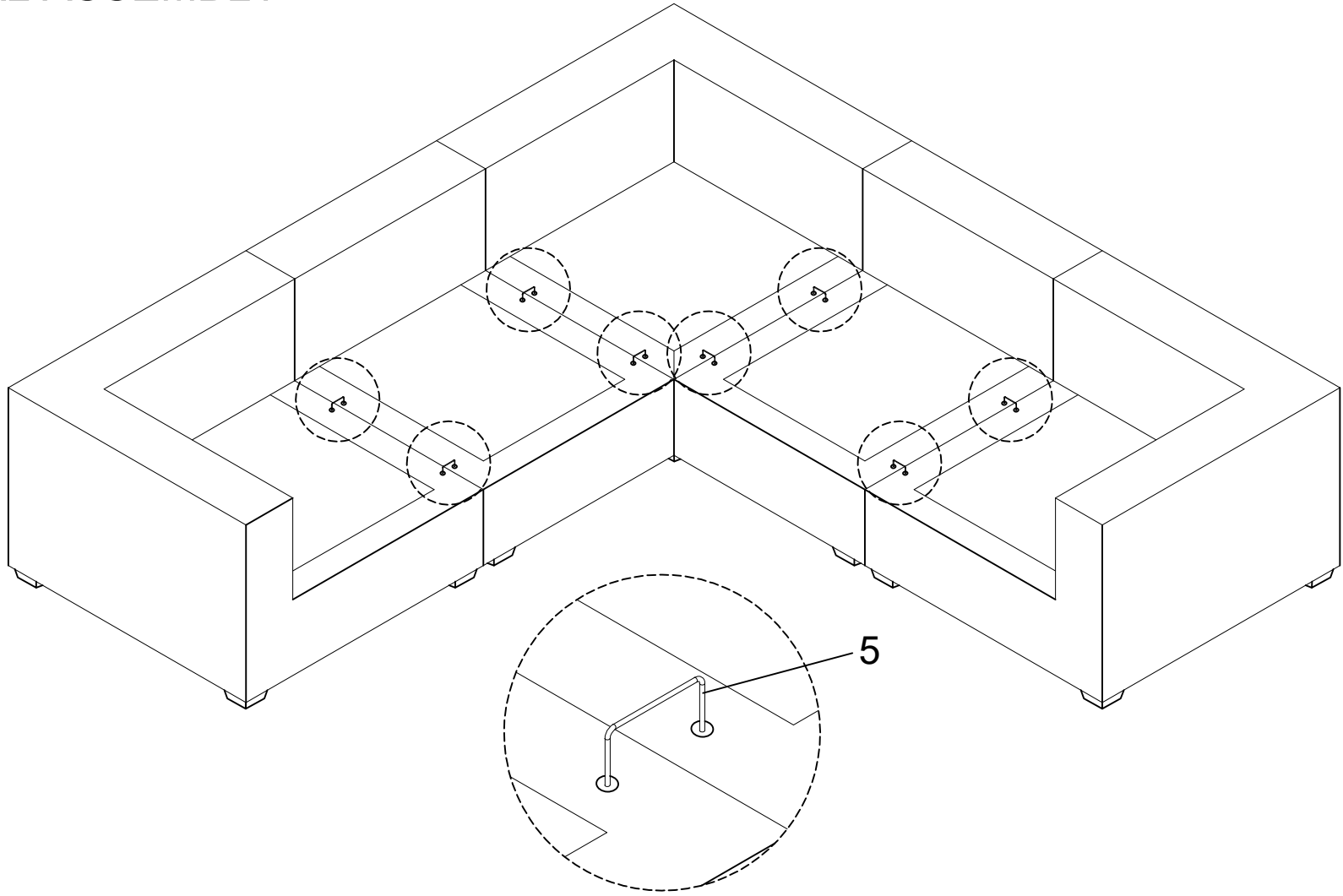

### COMPLETED.

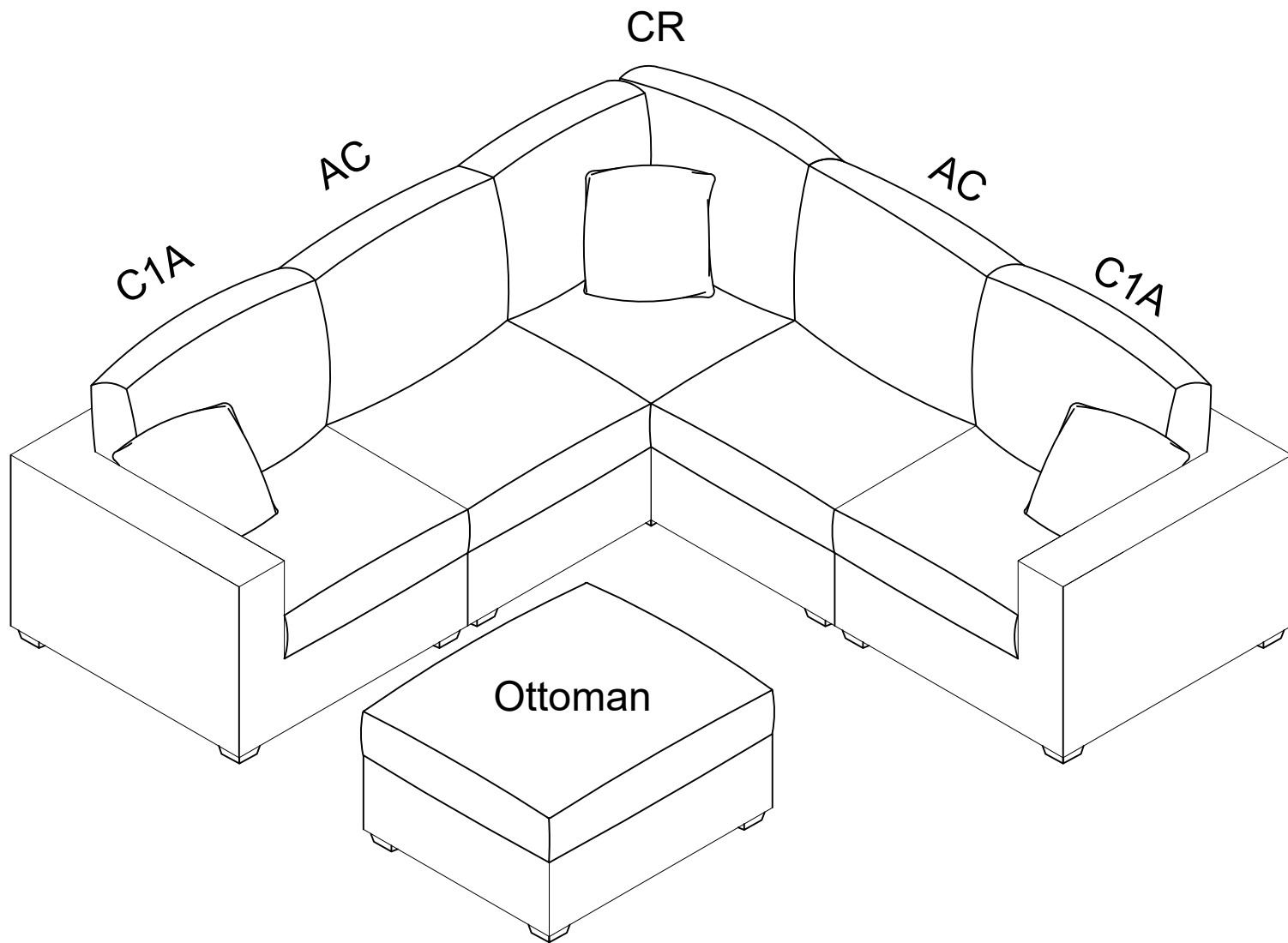

#### Care Instructions for Chenille Furniture:

In order to maintain the original appearance of your chenille furniture, please follow the simple care procedures below:





- Avoid exposing furniture directly to sunlight or heating and air conditioning outlets. Sunlight and/or exposure to heating and air conditioning outlets will fade/damage chenille.
- Vacuum or wipe with a soft cloth to remove dust.
- Hardware may loosen over time. Periodically check to make sure all connections are tight. Re-tighten if necessary.

For item use on wooden floor, hard surfaces or carpets, it is recommended to install protective pads under all legs and supports to prevent damage/scratches and discoloration.

# ASSEMBLY INSTRUCTIONS

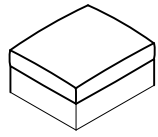
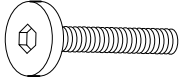
## OTTOMAN

**!** The legs and hardware are stored in the bottom of the ottoman, please take them out for assembly.  
 Note: Do not use power tools for assembly. Power tools increase the risk of over tightening which leads to splitting or cracking the wood.

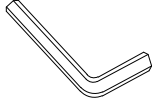
COMPONENT LIST				HARDWARE LIST			
PART	DRAWING	DESCRIPTION	QTY	PART	DRAWING	DESCRIPTION	QTY
A		Ottoman	1 PC	1		Bolt Ø5/16"x2 -1/2"	4 PCS
B		Plastic Leg 4-1/8"x4-1/8"x2-1/3"	4 PCS	2		Spring Washer Ø5/16"	4 PCS
				3		Flat Washer Ø5/16"x3/4"	4 PCS
				4		Allen KeyM4 2-1/3"	1 PC

### STEP 1:

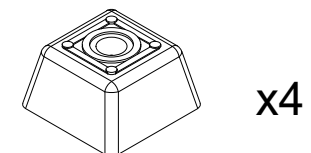
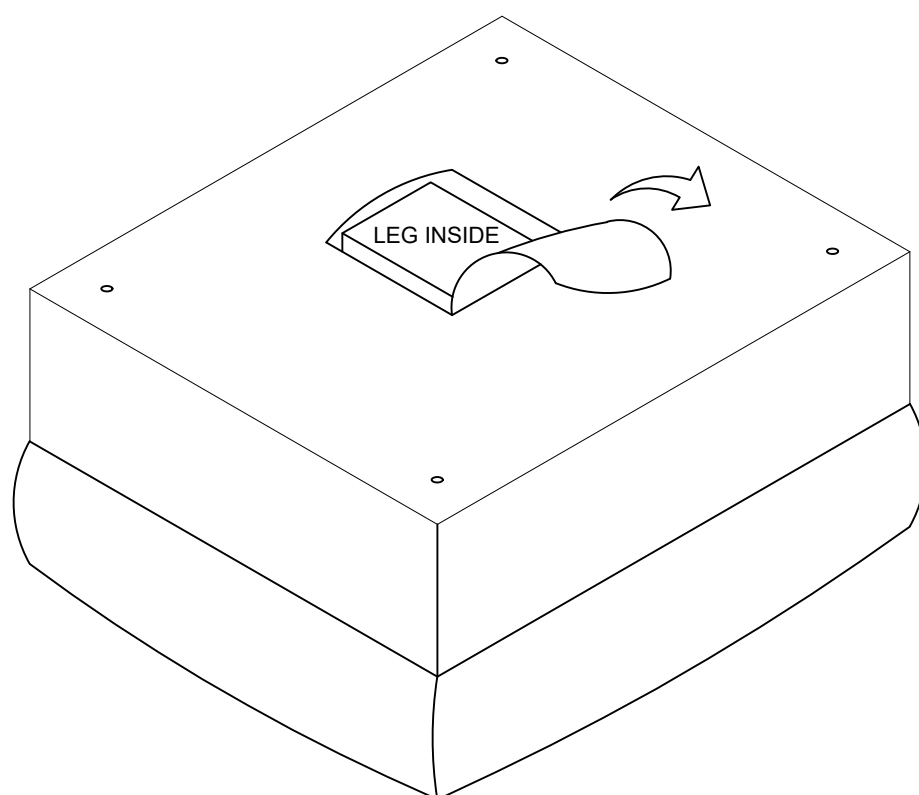

x4

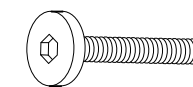

x4



x4



x4



x1

# ASSEMBLY INSTRUCTIONS

## OTTOMAN

STEP 2:

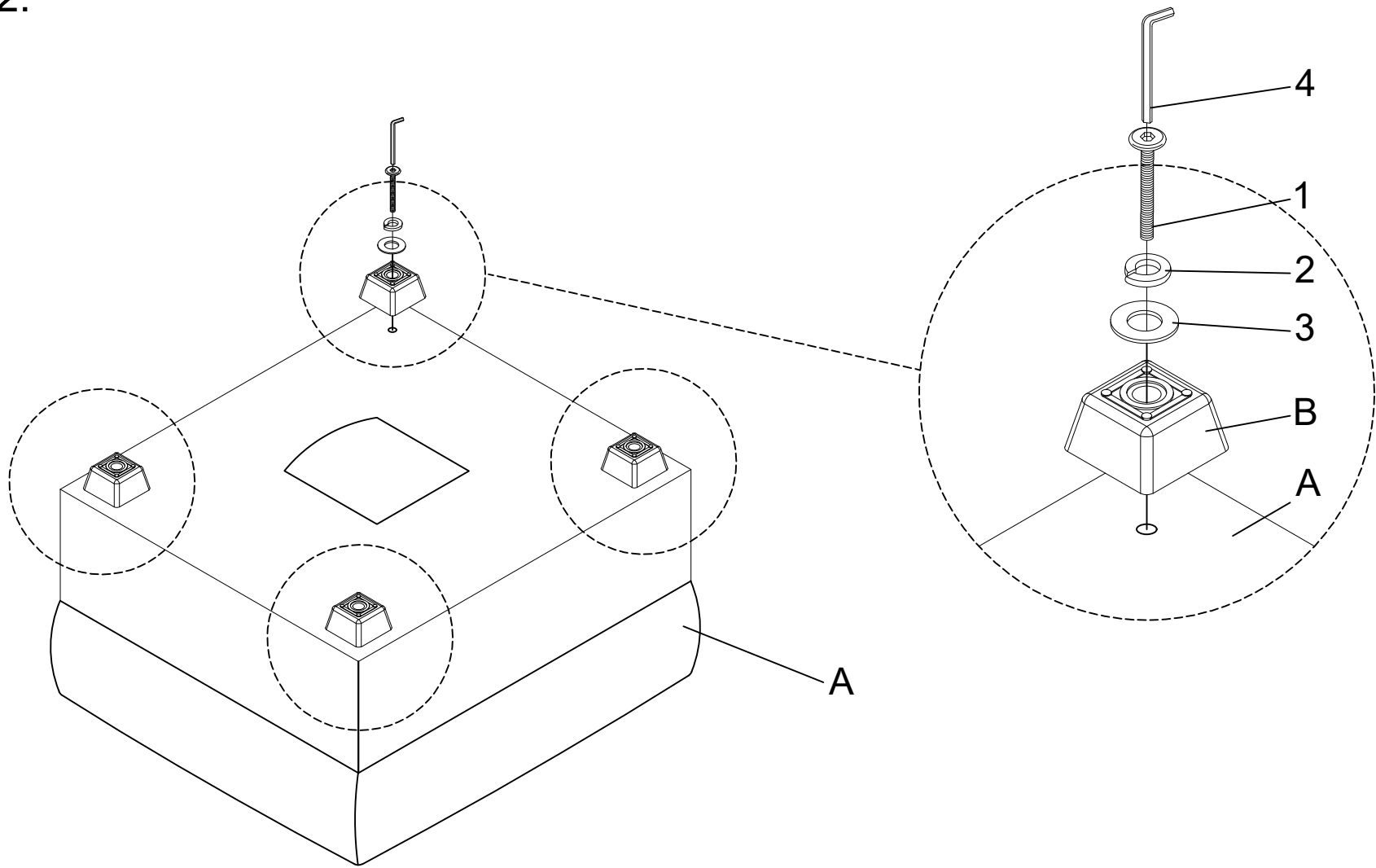

COMPLETED.

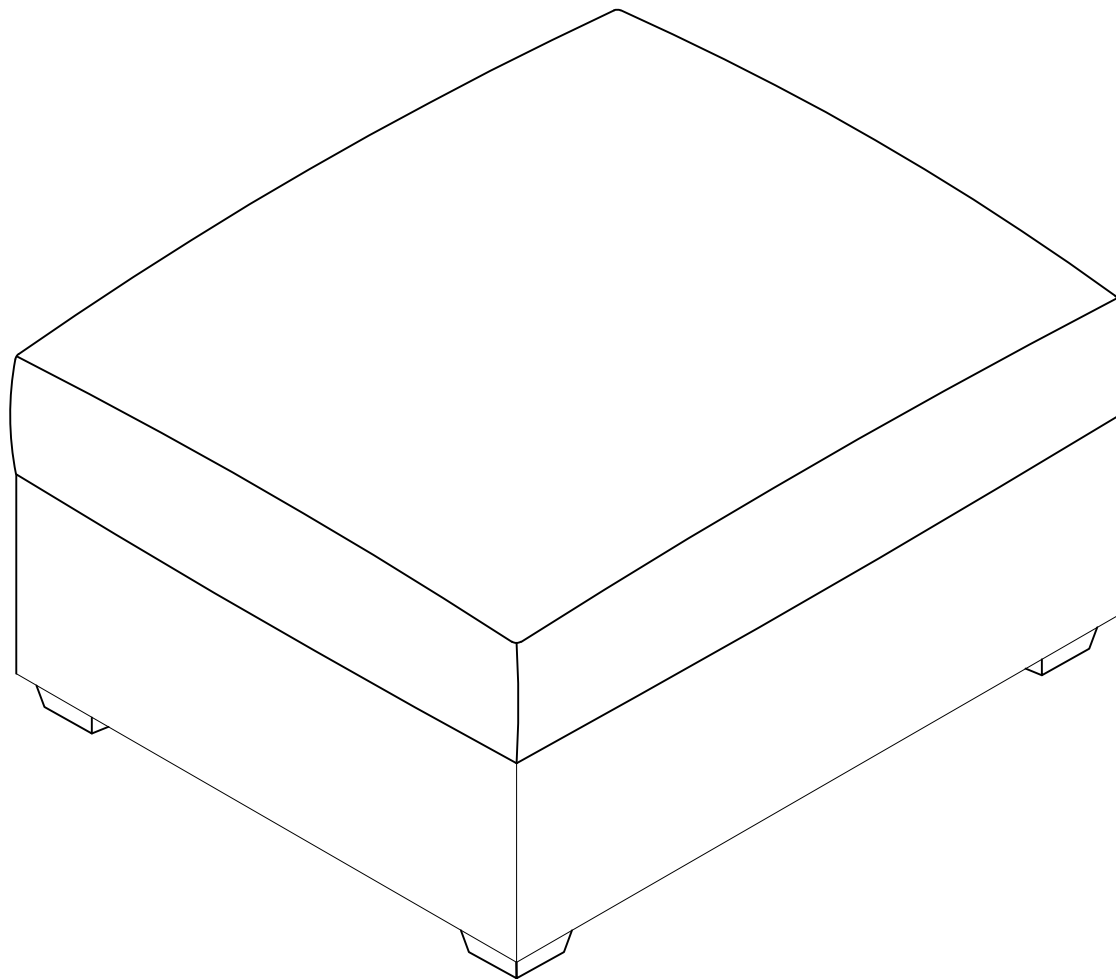

# ASSEMBLY INSTRUCTIONS

## OTTOMAN

### SECTIONAL ASSEMBLY

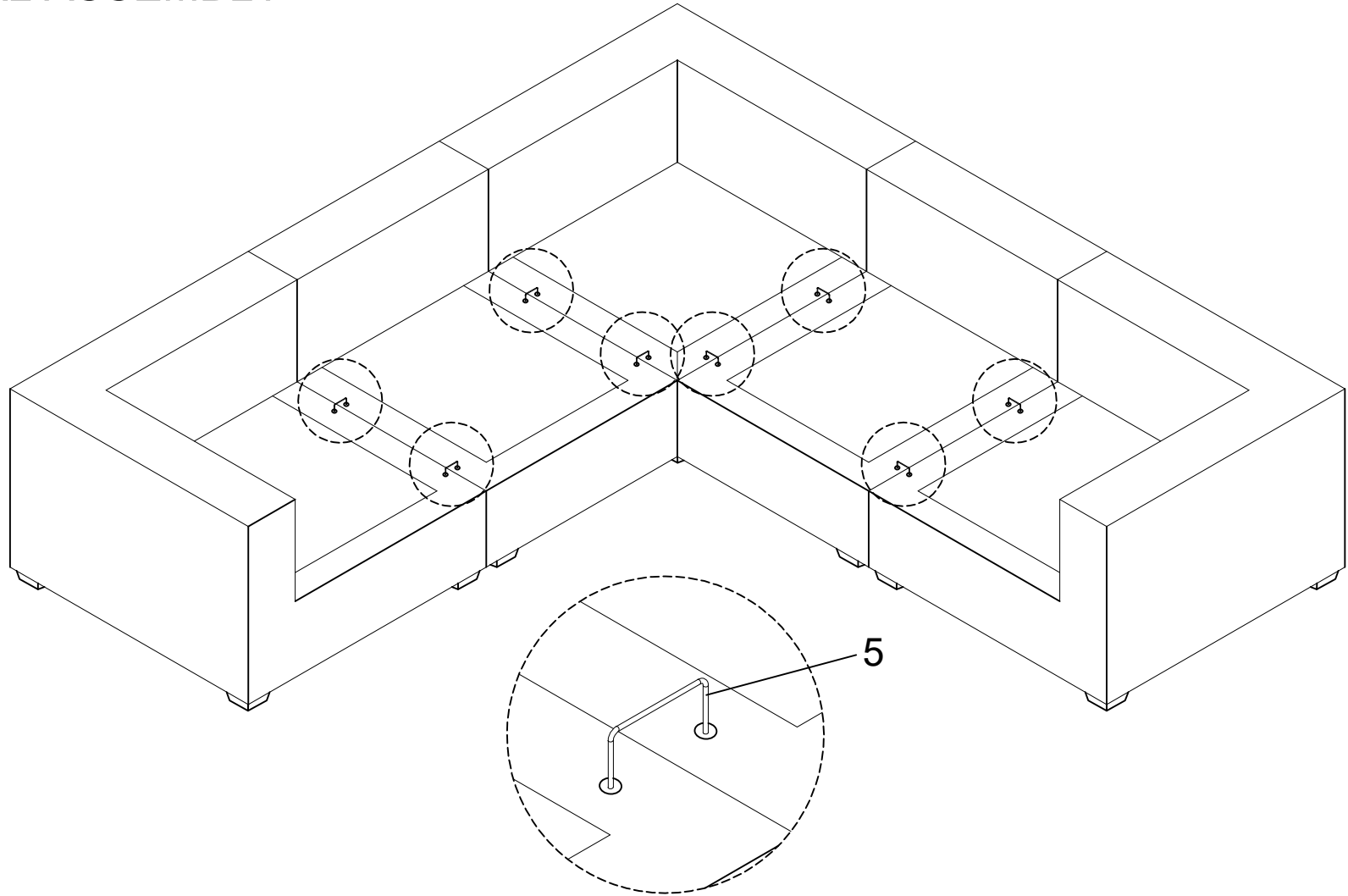

### COMPLETED.

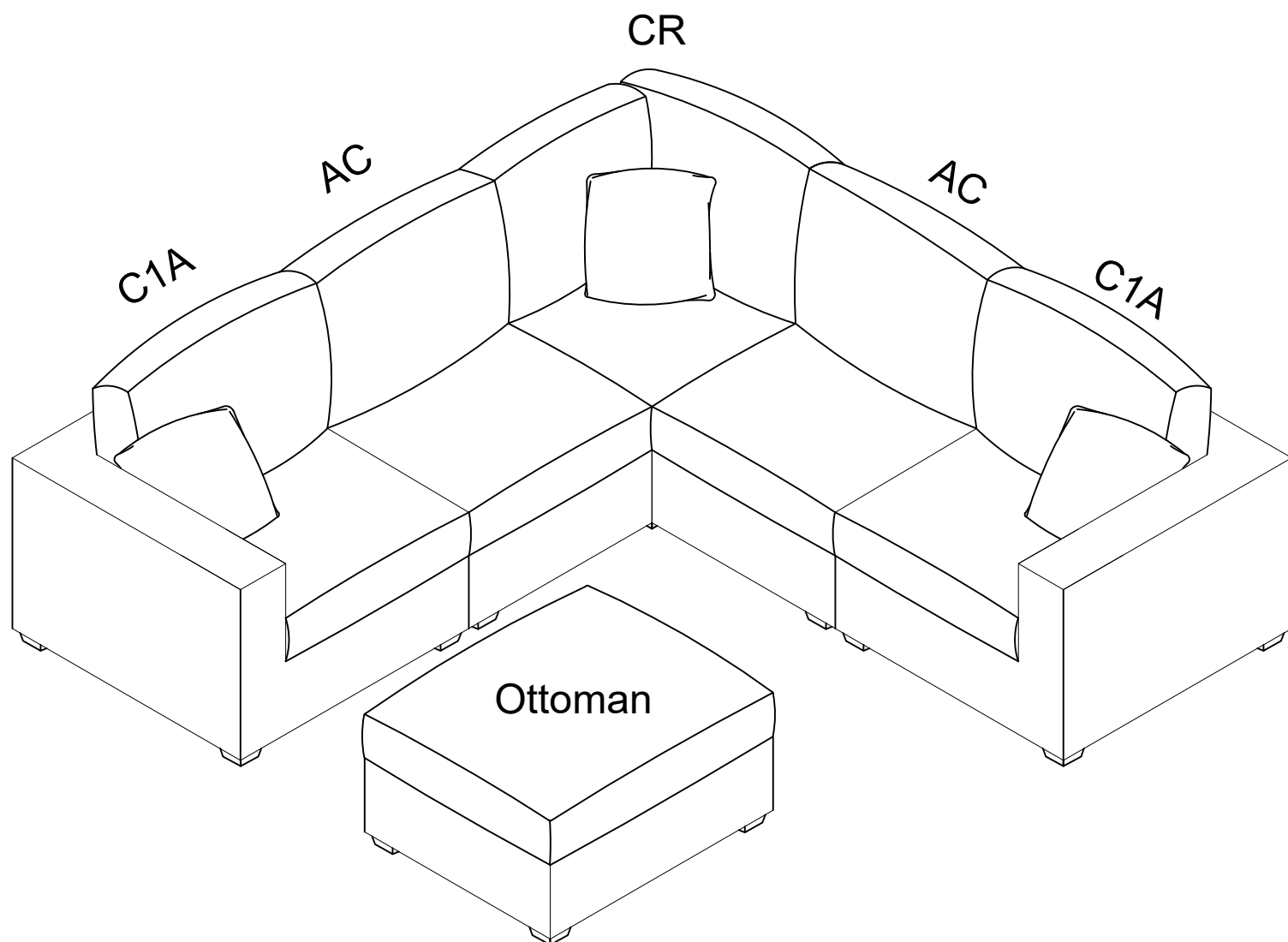

#### Care Instructions for Chenille Furniture:

In order to maintain the original appearance of your chenille furniture, please follow the simple care procedures below:

- Avoid exposing furniture directly to sunlight or heating and air conditioning outlets. Sunlight and/or exposure to heating and air conditioning outlets will fade/damage chenille.
- Vacuum or wipe with a soft cloth to remove dust.
- Hardware may loosen over time. Periodically check to make sure all connections are tight. Re-tighten if necessary.

For item use on wooden floor, hard surfaces or carpets, it is recommended to install protective pads under all legs and supports to prevent damage/scratches and discoloration.