

# ASSEMBLY INSTRUCTION

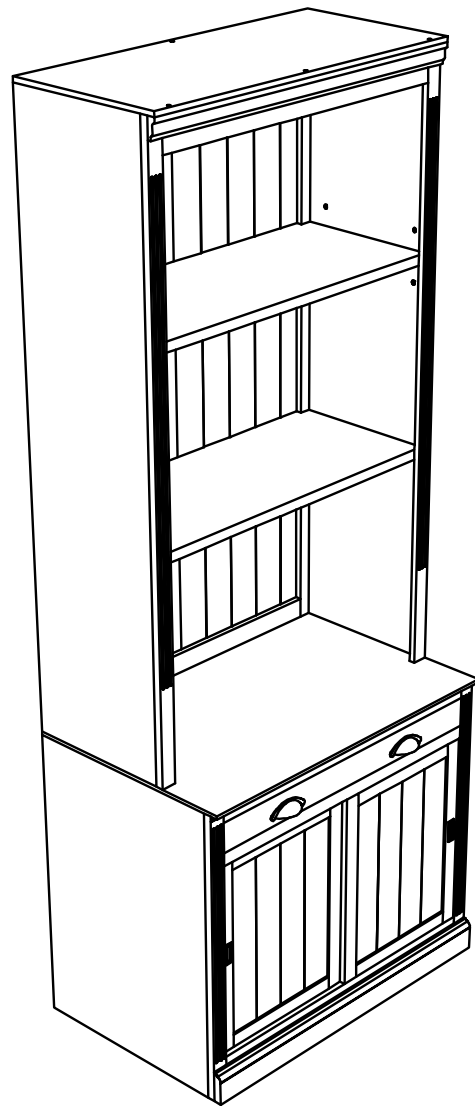

# PARTS LIST

(A)

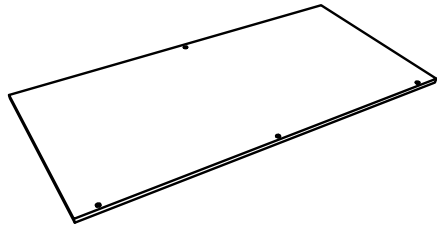

Quantity:  
1 pc

(B)

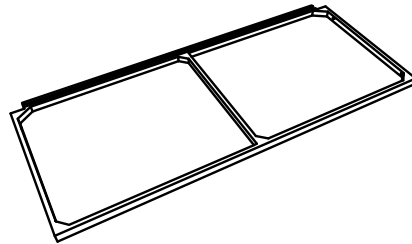

Quantity:  
2 pcs

(CL)

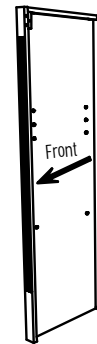

Quantity:  
1 pc

(CR)

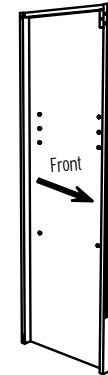

Quantity:  
1 pc

(D)

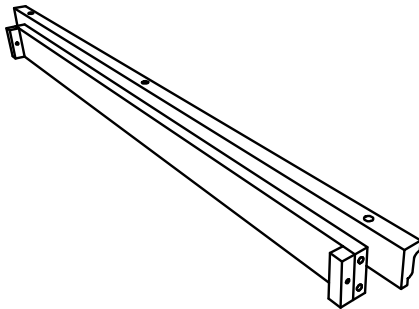

Quantity:  
1 pc

(E)

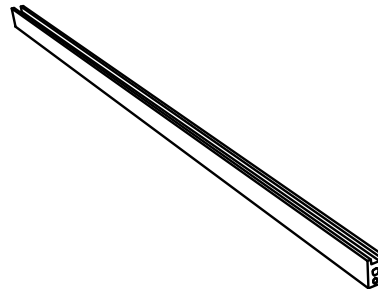

Quantity:  
1 pc

(F)

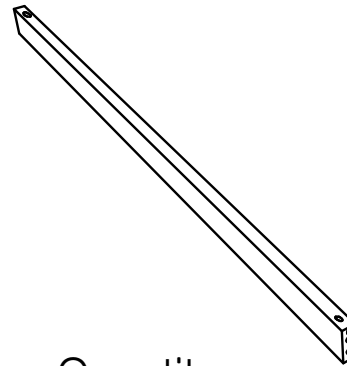

Quantity:  
1 pc

(G)

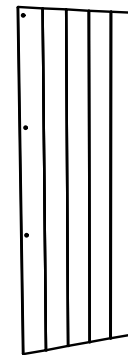

Quantity:  
2 pcs

# PARTS LIST

(H)

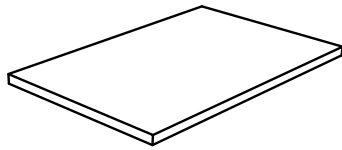

Quantity:  
1 pc

(IL)

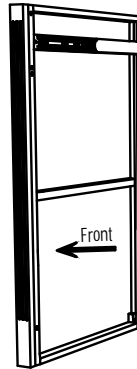

Quantity:  
1 pc

(IR)

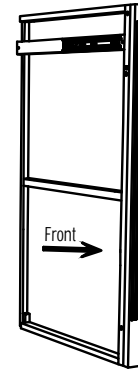

Quantity:  
1 pc

(J)

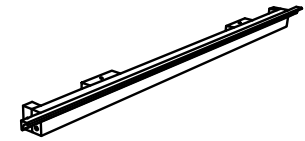

Quantity:  
1 pc

(K)

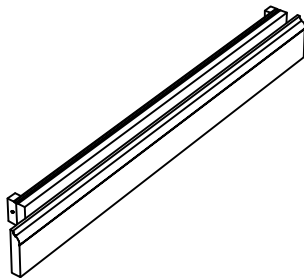

Quantity:  
1 pc

(L)

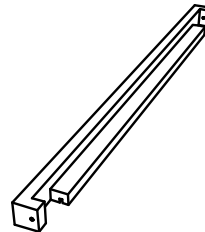

Quantity:  
1 pc

(M)

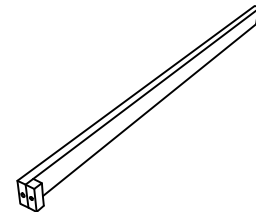

Quantity:  
1 pc

(N)

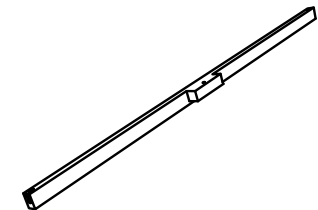

Quantity:  
1 pc

# PARTS LIST

OL

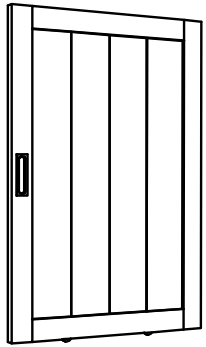

Quantity:  
1 pc

OR

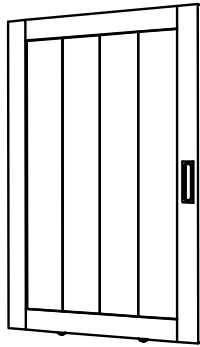

Quantity:  
1 pc

P

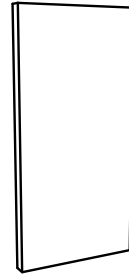

Quantity:  
2 pcs

Q

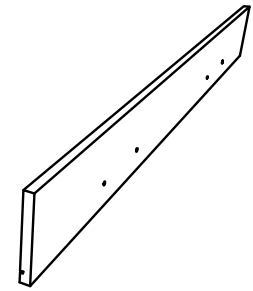

Quantity:  
1 pc

R

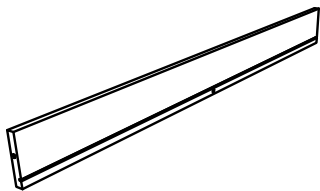

Quantity:  
1 pc

S

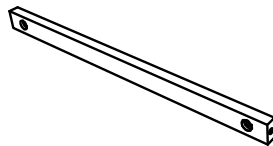

Quantity:  
1 pc

TL

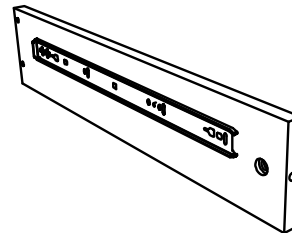

Quantity:  
1 pc

TR

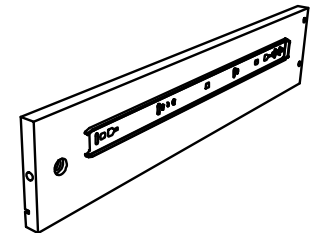

Quantity:  
1 pc

PARTS LIST

U



Quantity:  
1 pc

X

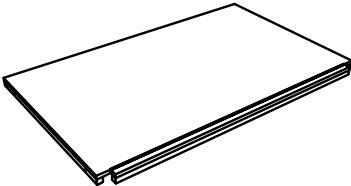

Quantity:  
1 pc

Y

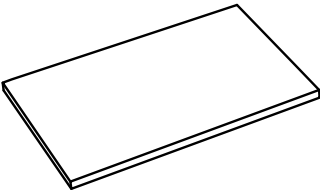



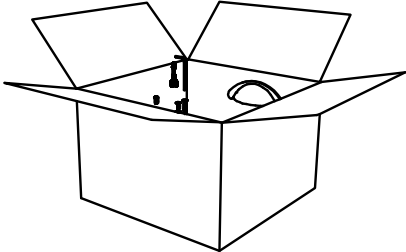









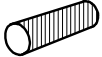

Quantity:  
1 pc

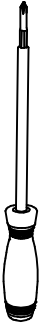
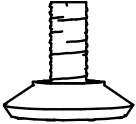

HARDWARE

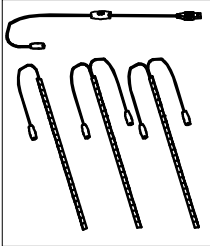
# HARDWARE LIST

<p>①</p>  <p>Allen key Quantity: 1 pc</p>	<p>②</p>  <p>Cam lock pin Cam lock Quantity: 4 pcs + extra 1pc</p>	<p>③</p>  <p>6x30mm Quantity: 41 pcs + extra 3pcs</p>	<p>④</p>  <p>6x16mm Quantity: 33 pcs + extra 3pcs</p>	<p>⑤</p>  <p>5x15mm Quantity: 4 pcs + extra 1pc</p>	<p>⑥</p>  <p>8x30mm Quantity: 20 pcs + extra 2pcs</p>	<p>⑦</p>  <p>4x30mm Quantity: 8 pcs + extra 1pc</p>	<p>⑧</p>  <p>3x15mm Quantity: 46 pcs + extra 3pcs</p>	<p>⑨</p>  <p>Quantity: 2 pcs</p>
<p>⑩</p>  <p>Screwdrivers Quantity: 1 pc</p>	<p>⑪</p>  <p>15x20mm Quantity: 4 pcs</p>	<p>⑫</p>  <p>20x80mm Quantity: 2 pcs</p>	<p>⑬</p>  <p>4x20mm Quantity: 4 pcs</p>	<p>⑭</p>  <p>4x25mm Quantity: 4 pcs</p>	<p>⑮</p>  <p>LED Light strip Quantity: 1 pc</p>	<p>⑯</p>  <p>2 SET</p> <p>Anti fall hardware Quantity: 1 pc</p>		

# COMPONENTS - KEY DIAGRAM

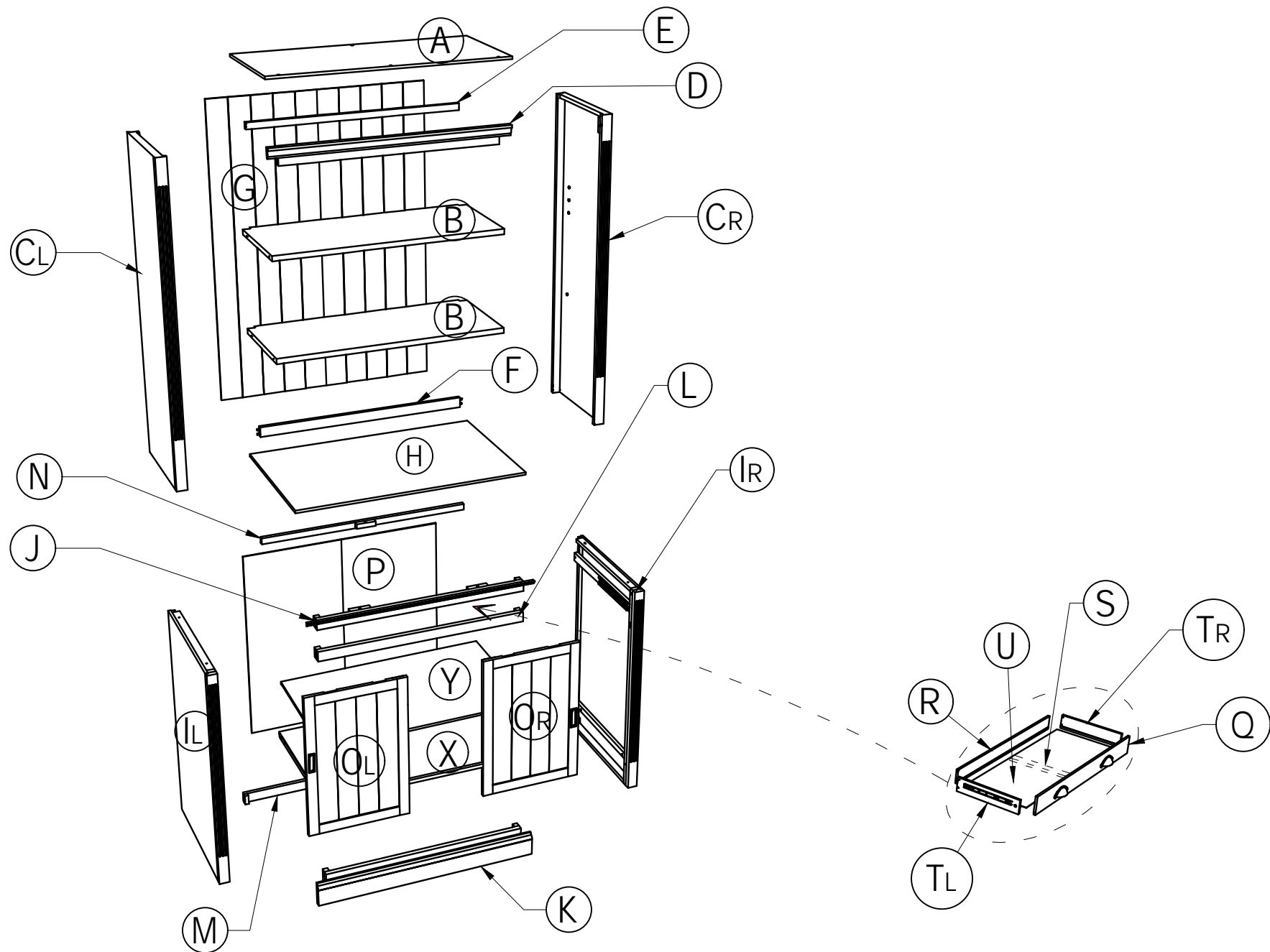

# COMPONENTS - KEY DIAGRAM

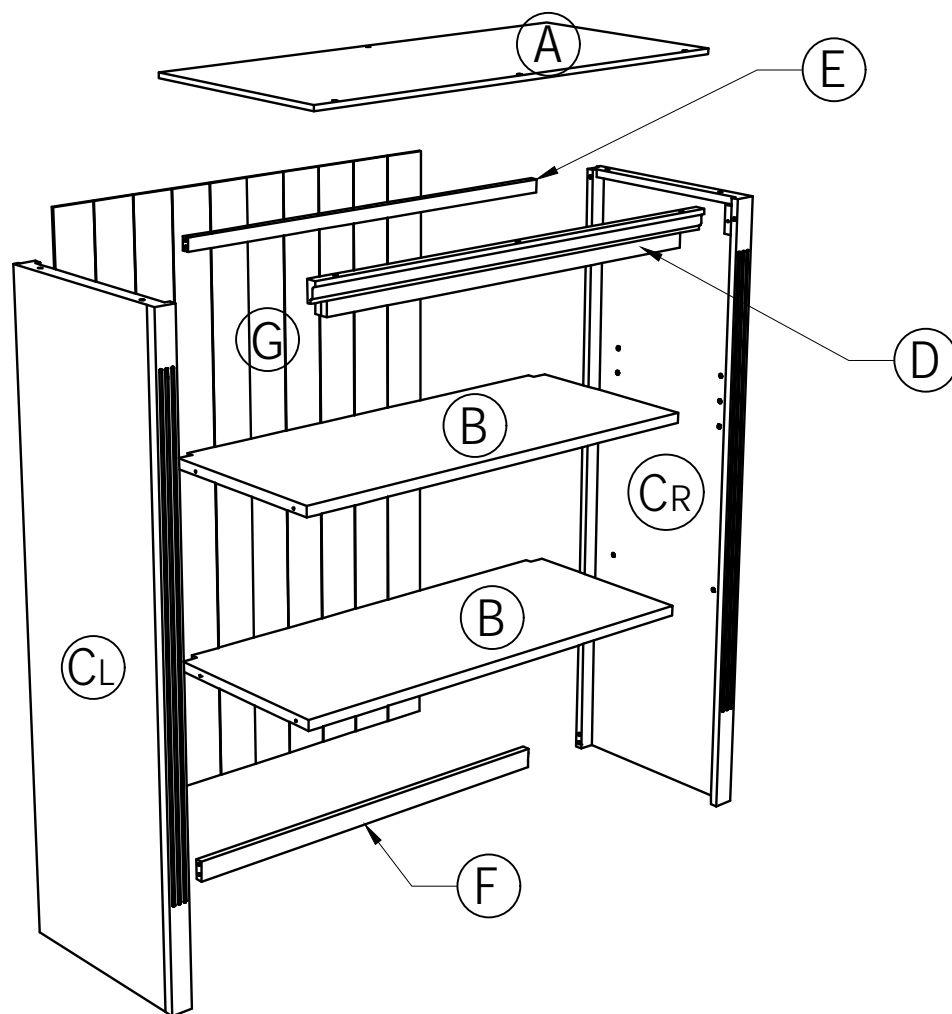

# STEP 1

1



1 pc

3

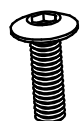

6x30mm  
1 pc

4



6x16mm  
1 pc

6

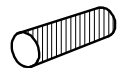

8x30mm  
4 pcs

7



4x30mm  
2 pcs

10



1 pc

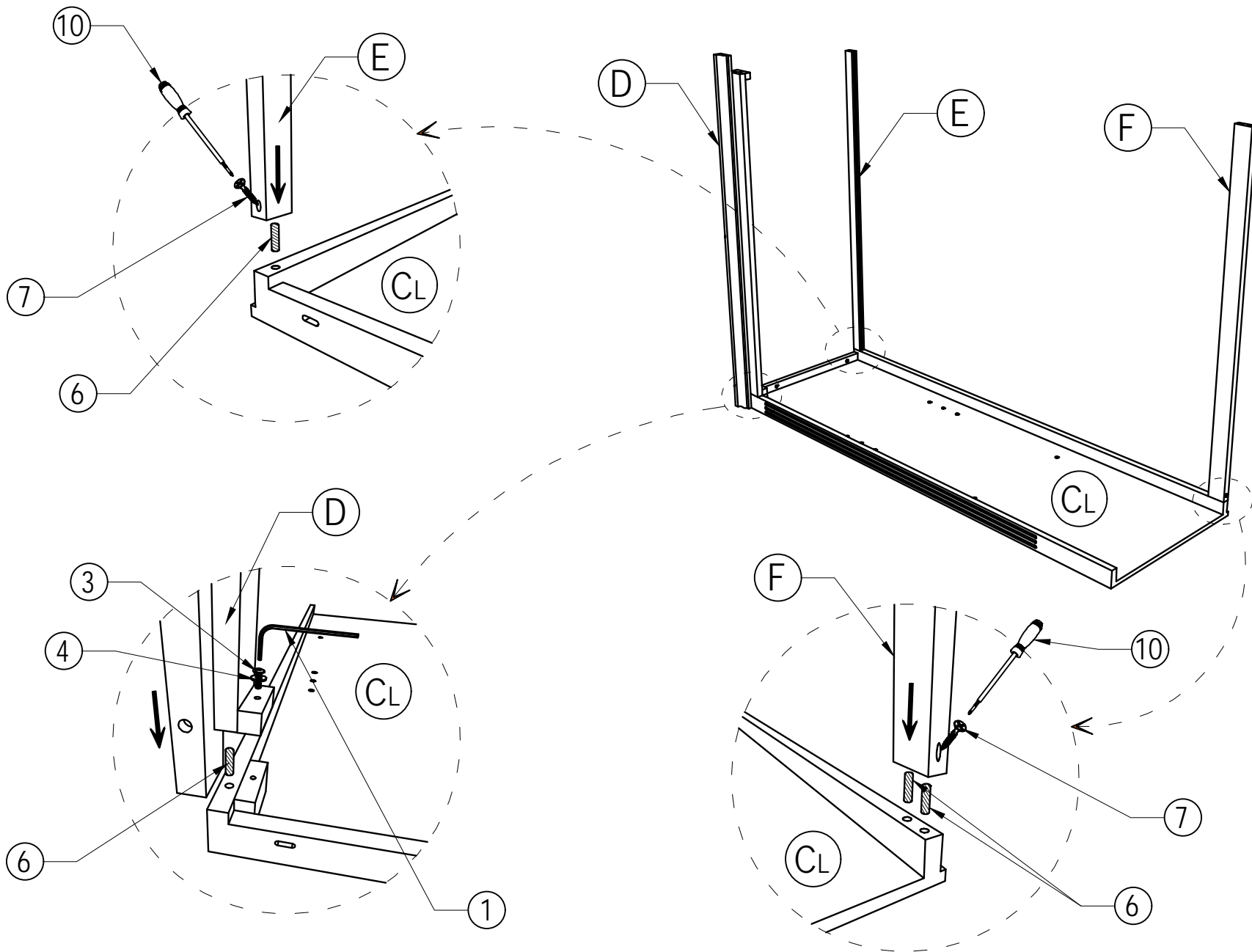

# STEP 2

1



1 pc

3

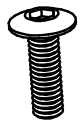

6x30mm  
4 pcs

4



6x16mm  
4 pcs

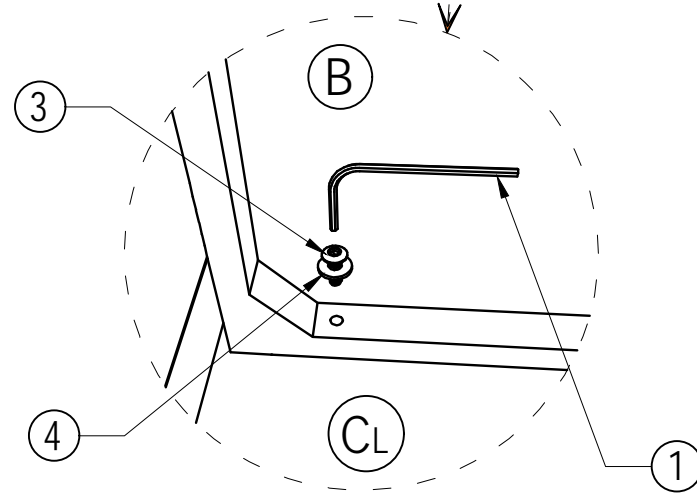
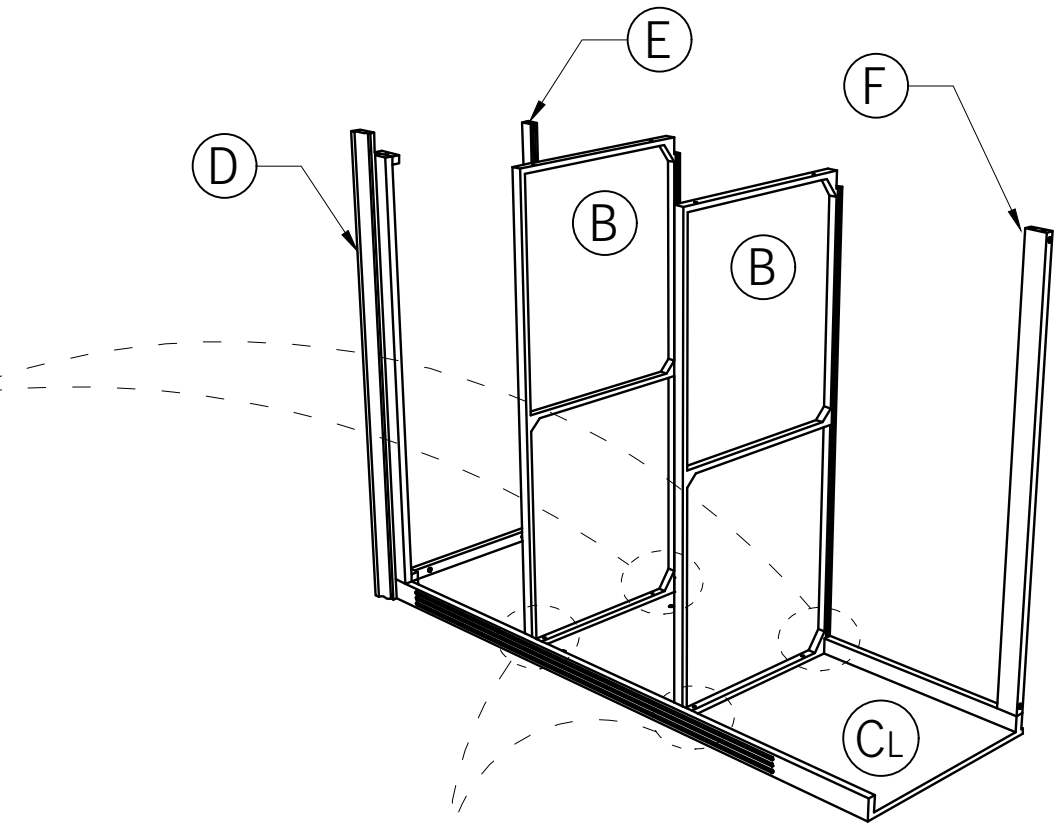
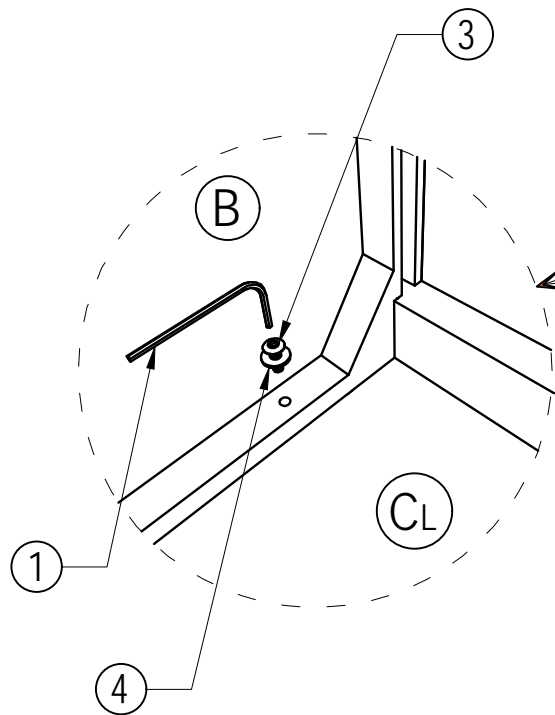

# STEP 3

1

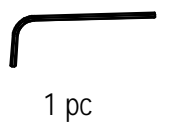

3



4



6

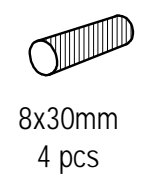

7



10

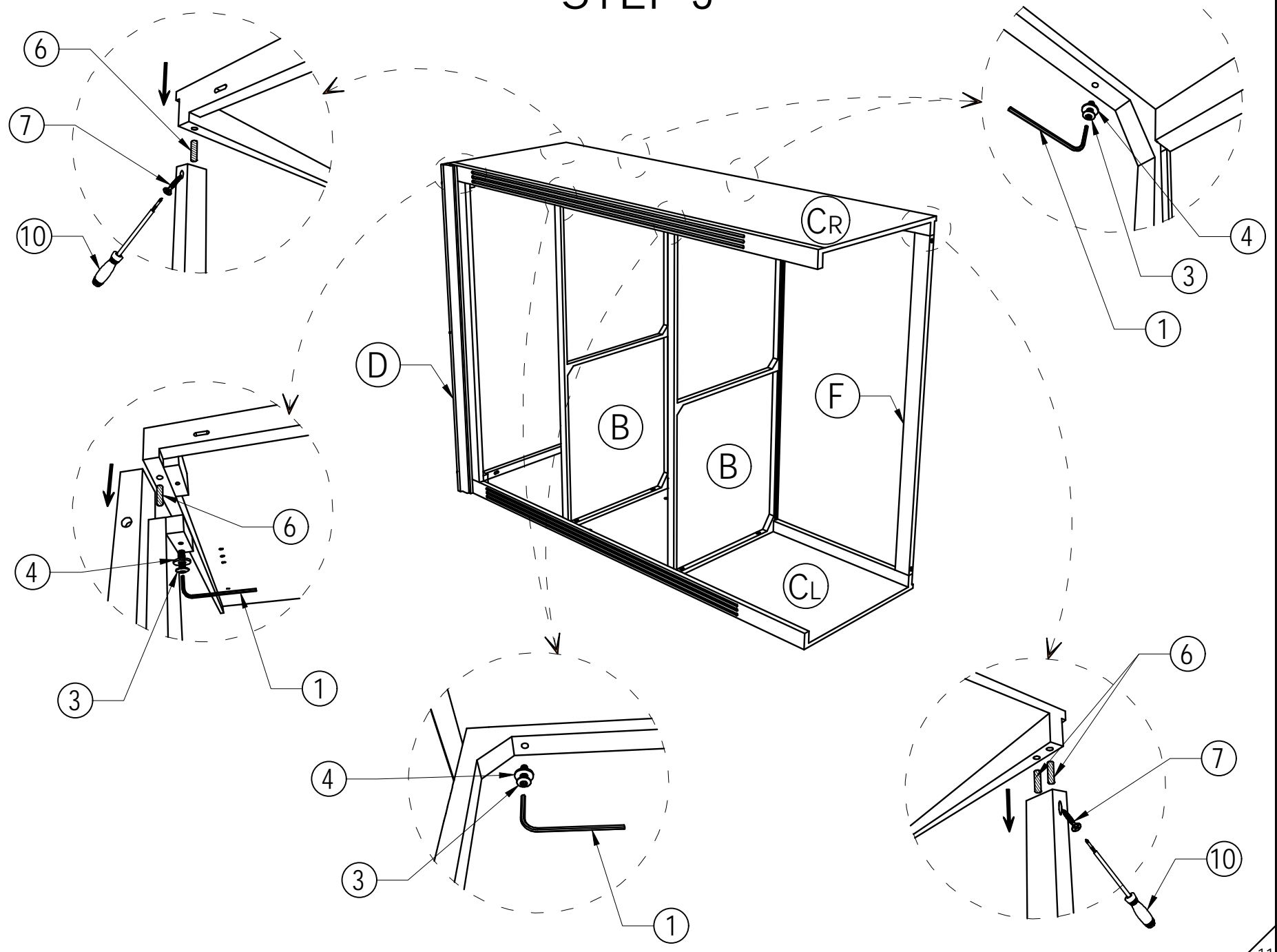
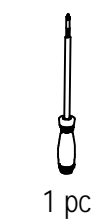

# STEP 4

1



1 pc

3

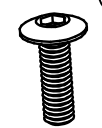

6x30mm  
4 pcs

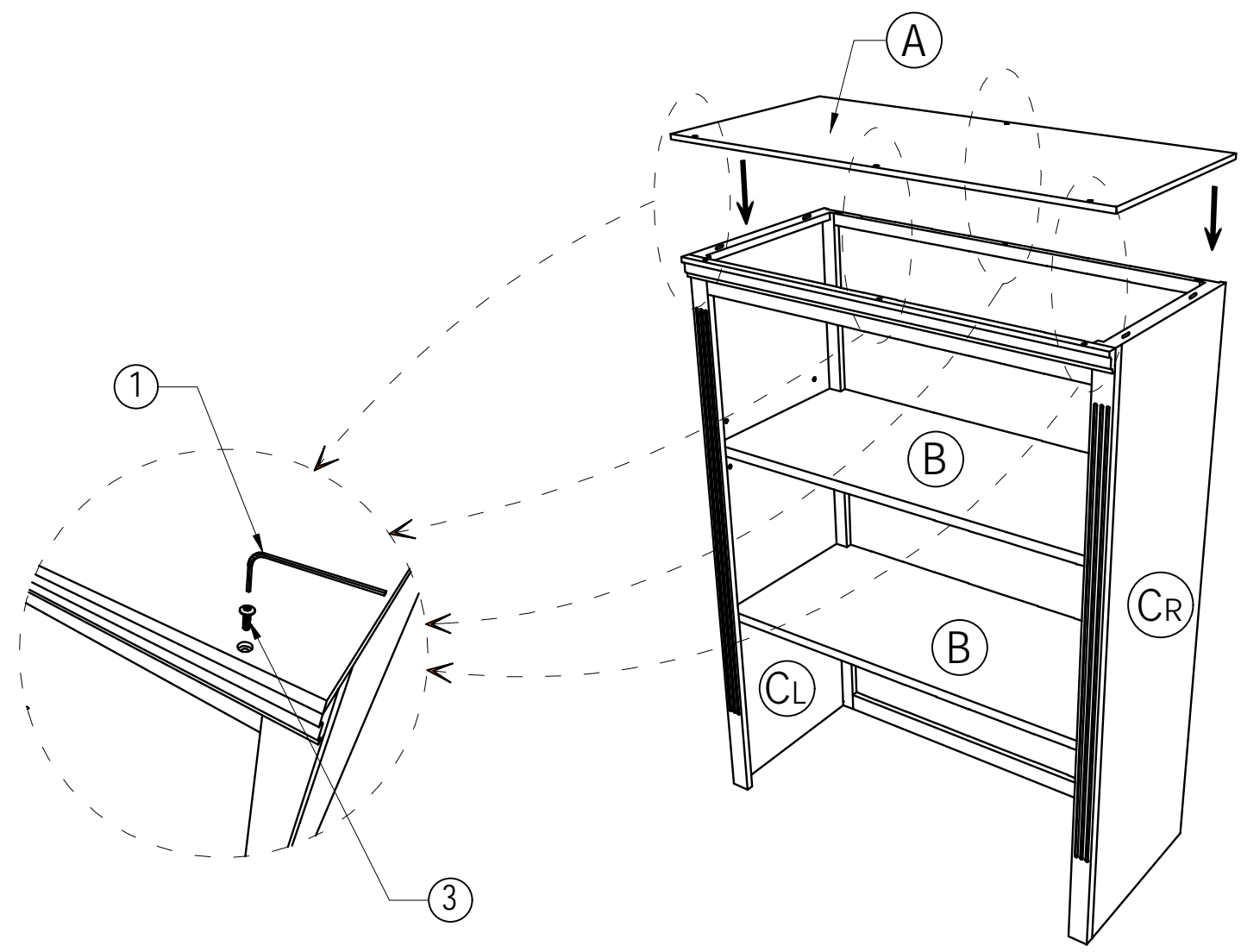

# STEP 5

1



1 pc

3

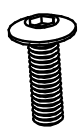

6x30mm  
4 pcs

4



6x16mm  
4 pcs

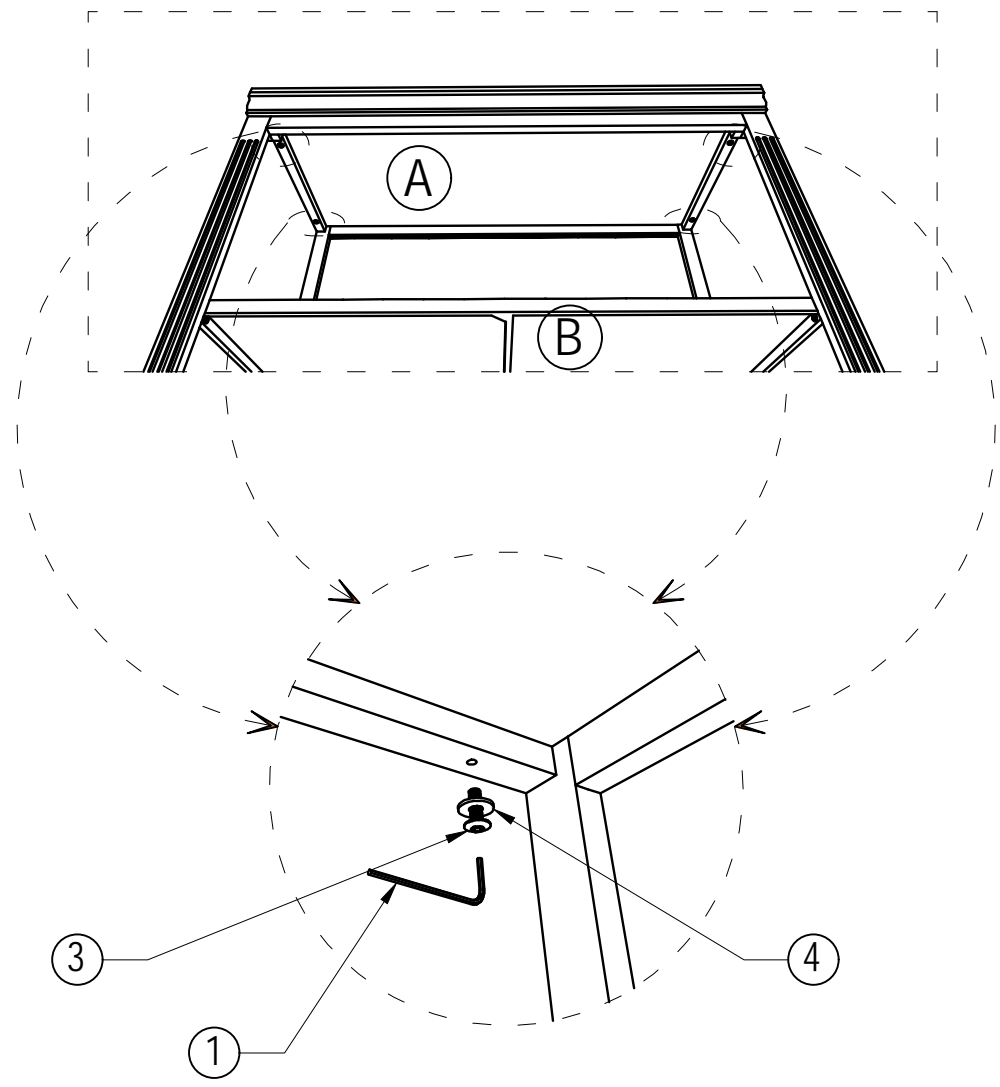

# STEP 6

8



3x15mm  
24 pcs

10



1 pc

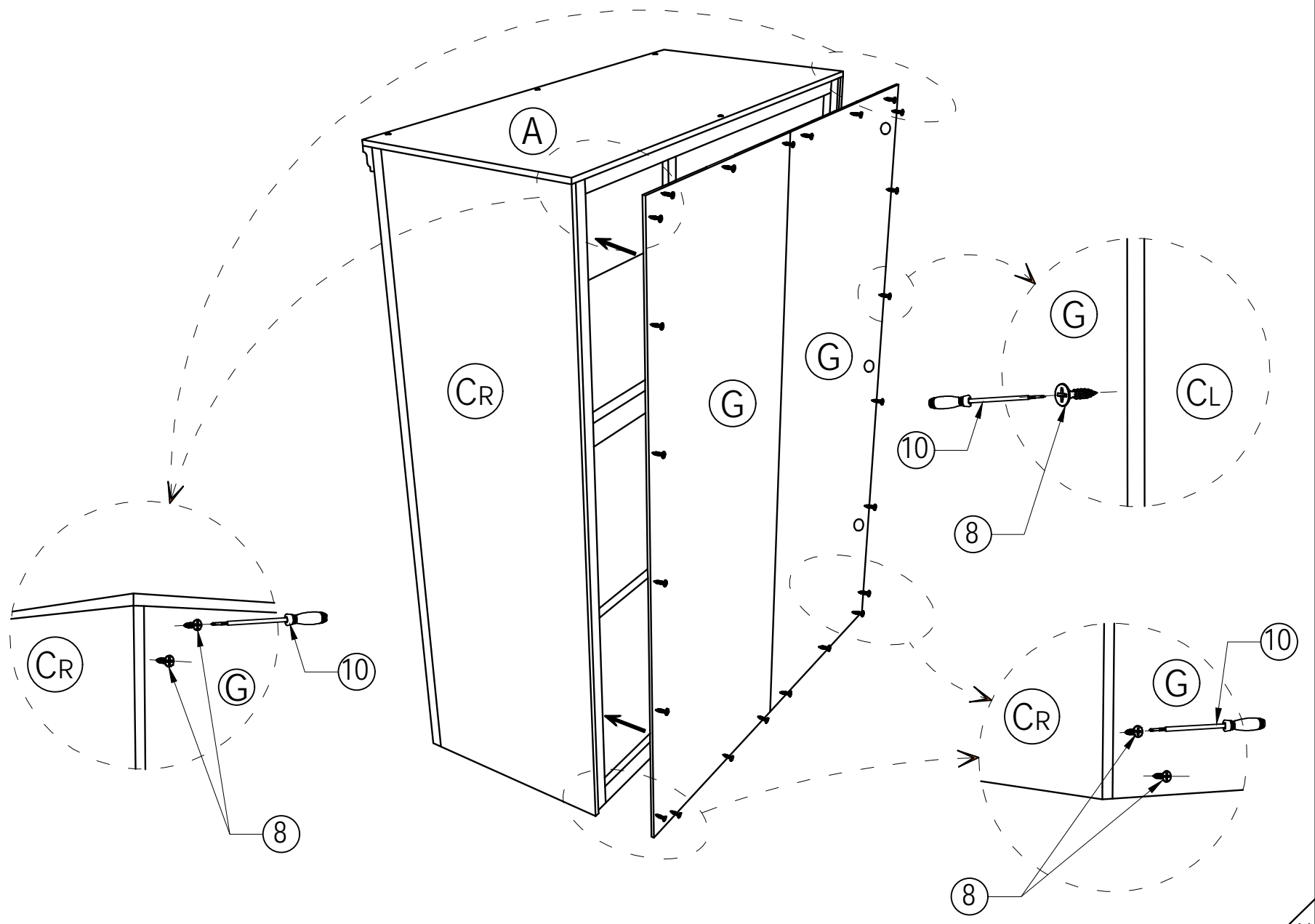

15

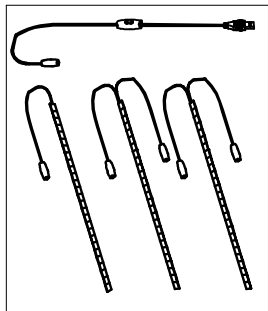

LED Light strip  
1 pc

# STEP 7

7.1. Connect LED strips together

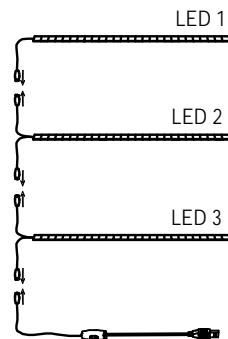

7.2. Insert the LED strips into the holes

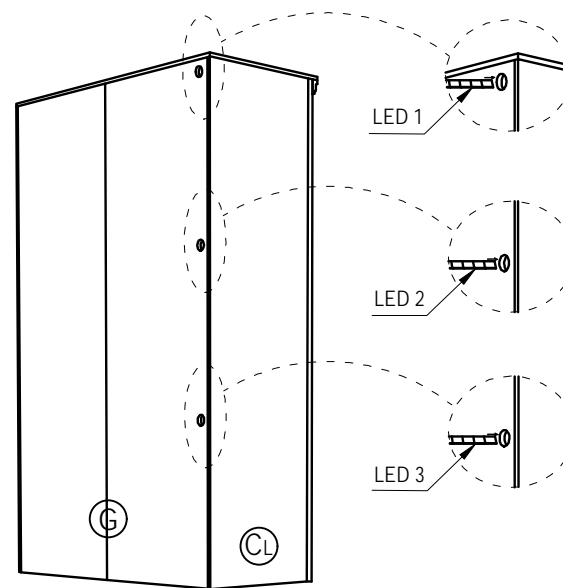

7.3.

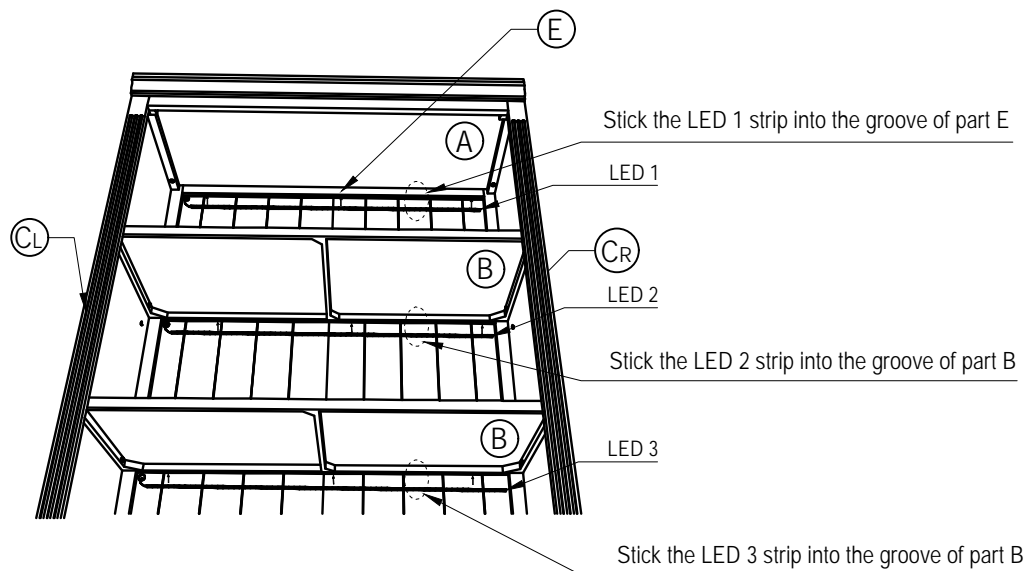

# COMPONENTS - KEY DIAGRAM

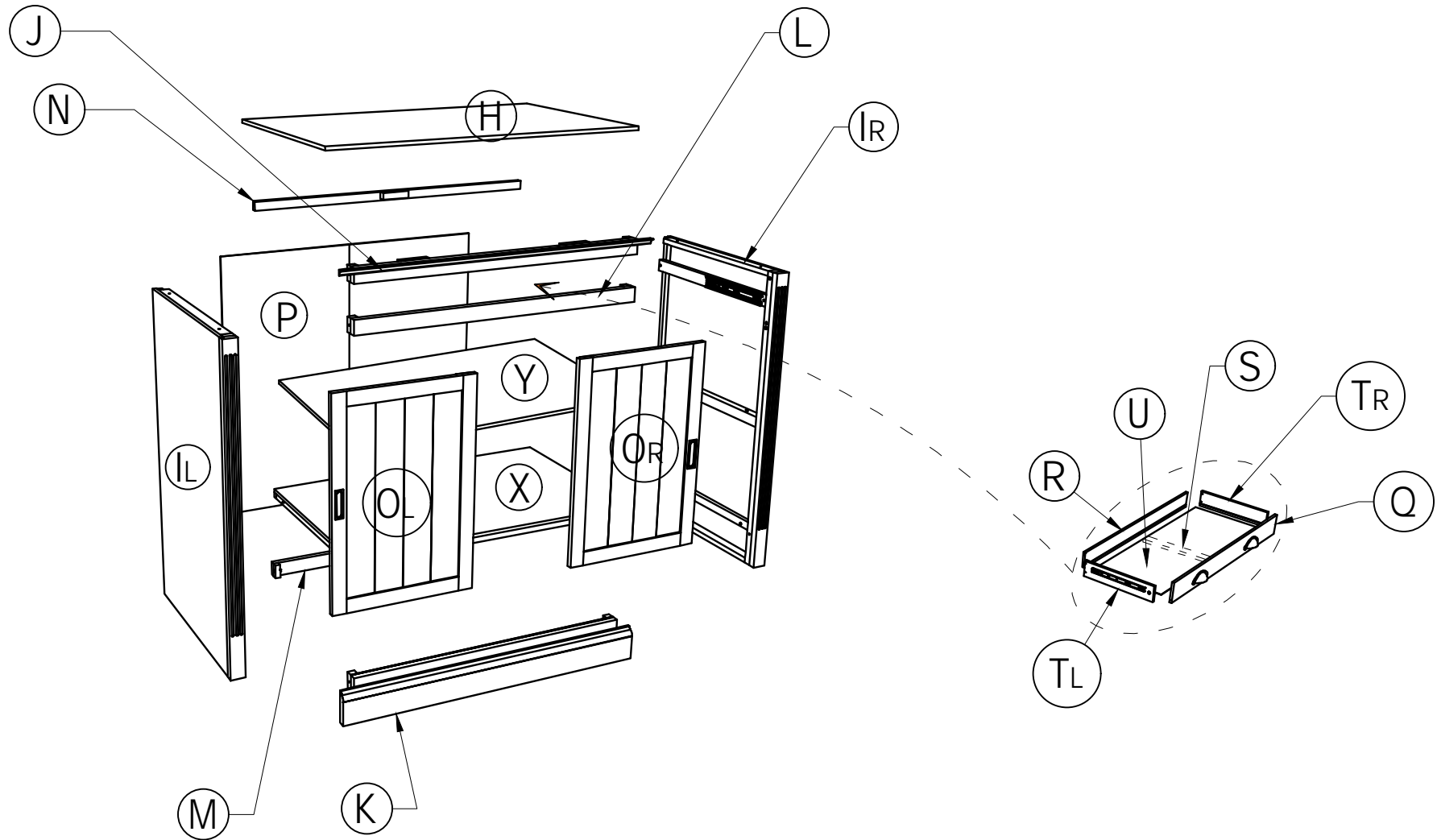

# STEP 8

①



1 pc

③

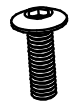

6x30mm  
3 pcs

④



6x16mm  
1 pc

⑥

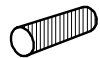

8x30mm  
2 pcs

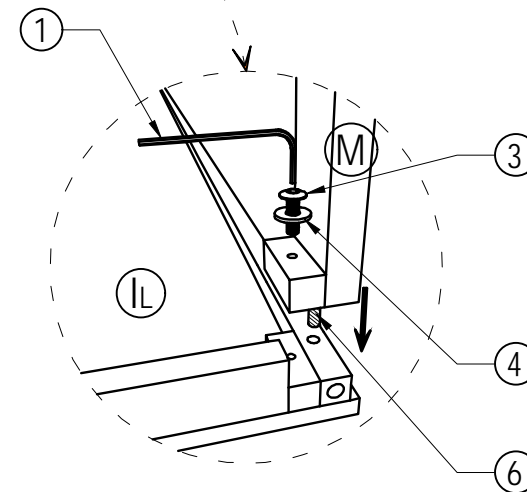
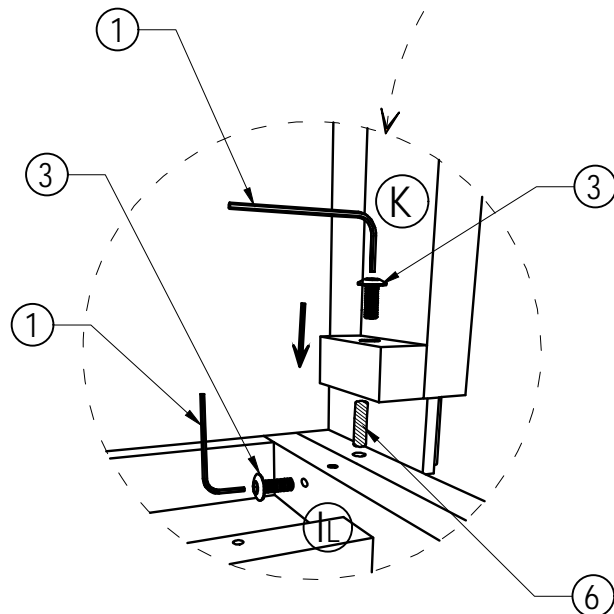
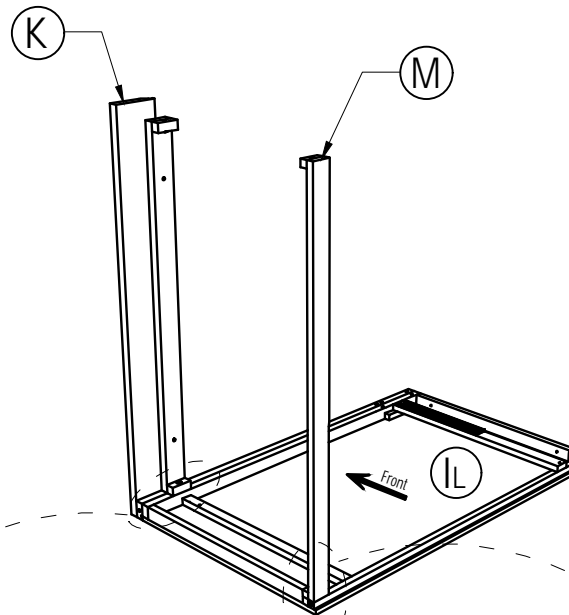

# STEP 9

①



1 pc

③



6x30mm  
2 pcs

④



6x16mm  
2 pcs

⑥

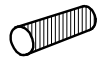

8x30mm  
4 pcs

⑦



4x30mm  
1 pc

⑩



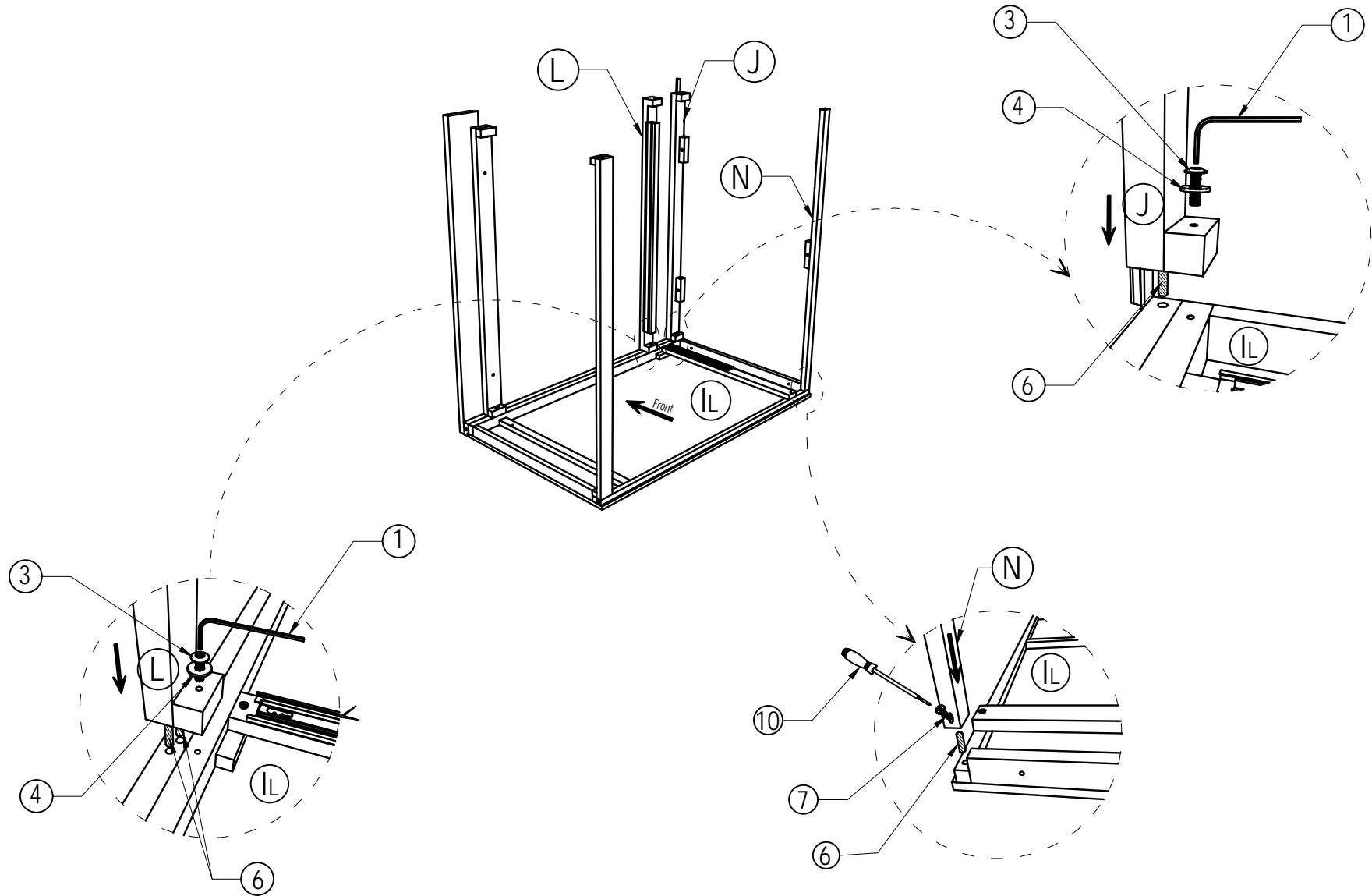

1 pc



# STEP 10

- 

1 pc
- 





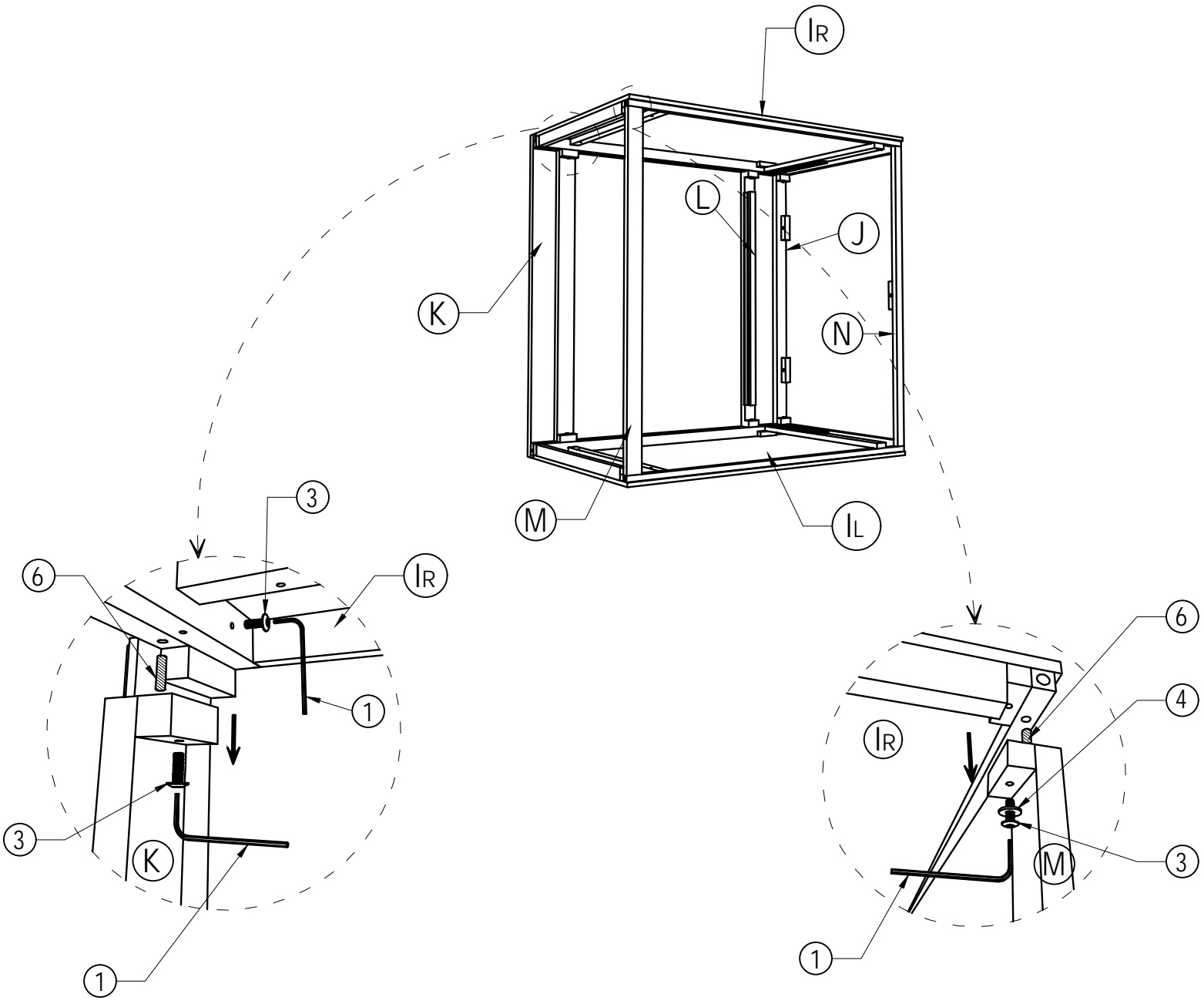

6x30mm  
3 pcs
- 

6x16mm  
1 pc
- 

8x30mm  
2 pcs



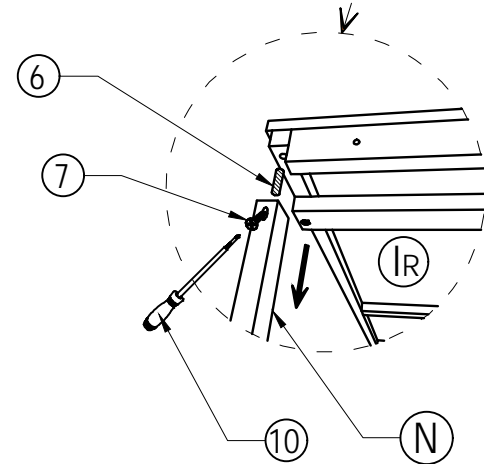
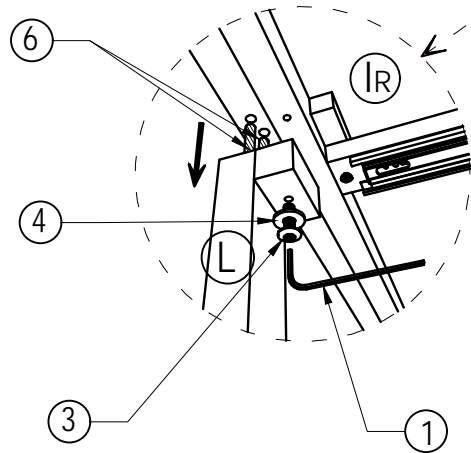
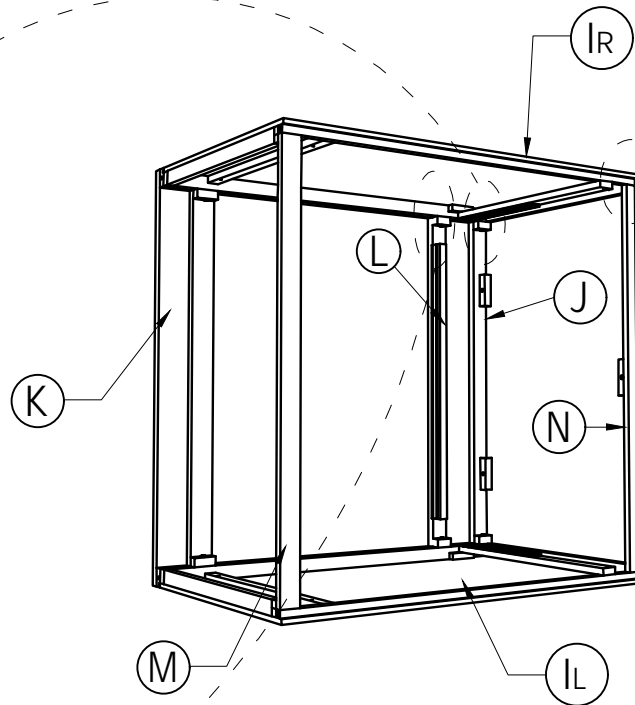
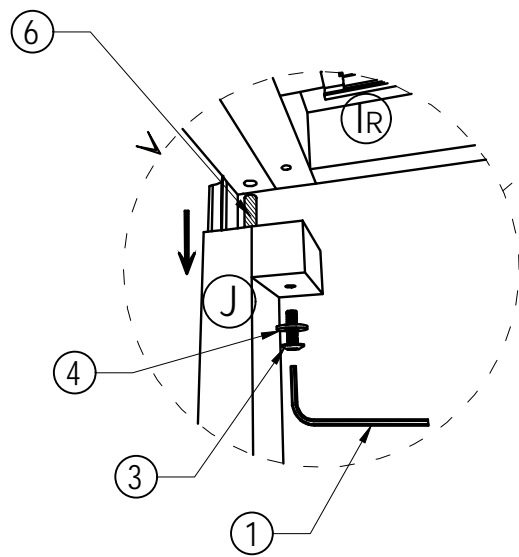

# STEP 11

- ①  
  
1 pc
- ③  
  
6x30mm  
2 pcs
- ④  
  
6x16mm  
2 pcs
- ⑥  
  
8x30mm  
4 pcs
- ⑦  
  
4x30mm  
1 pc
- ⑩  
  
1 pc



# STEP 12

- ①   
1 pc
- ③   
6x30mm  
6 pcs
- ④   
6x16mm  
6 pcs

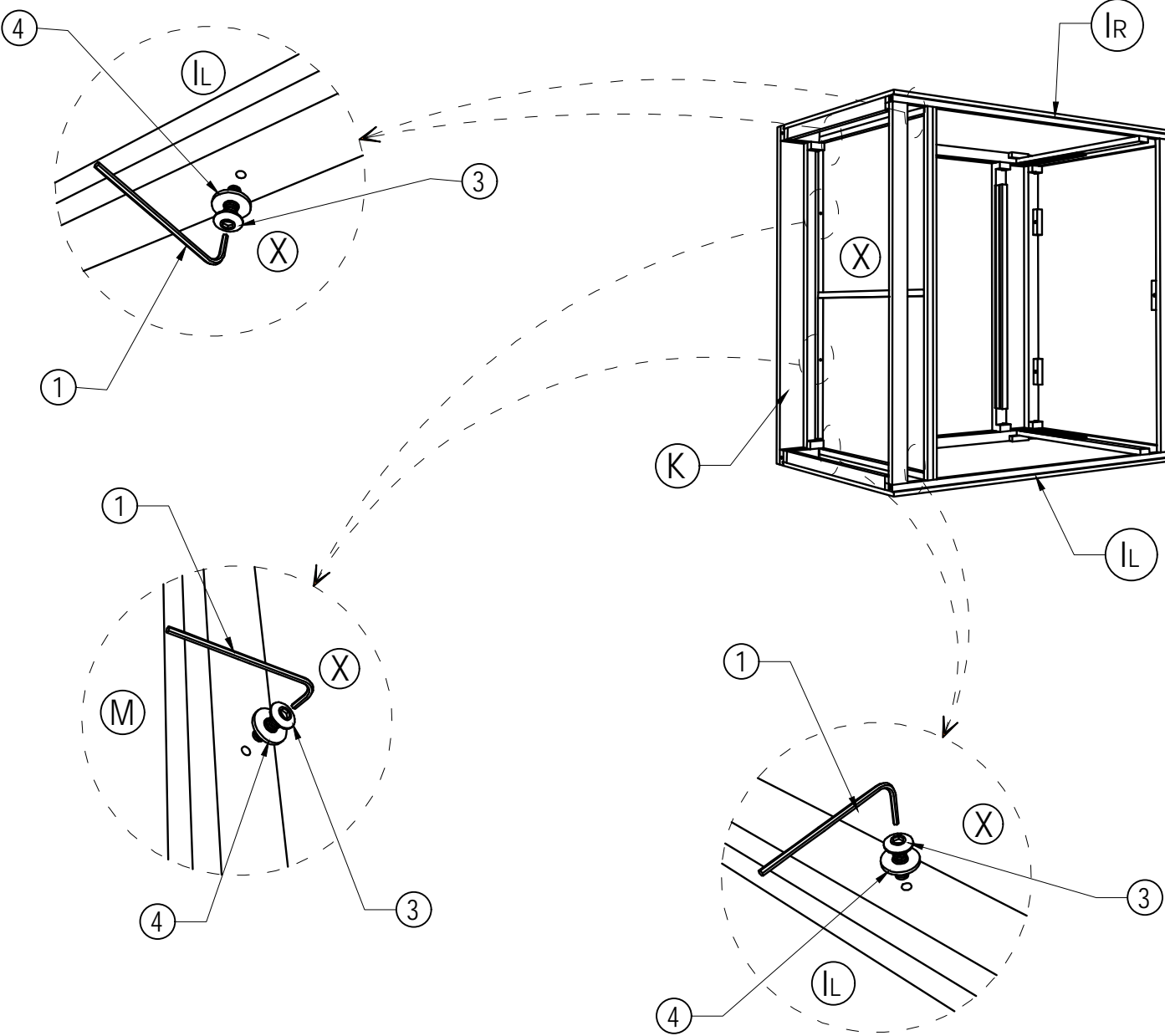

# STEP 13

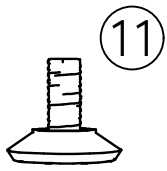

15x20mm  
4 pcs

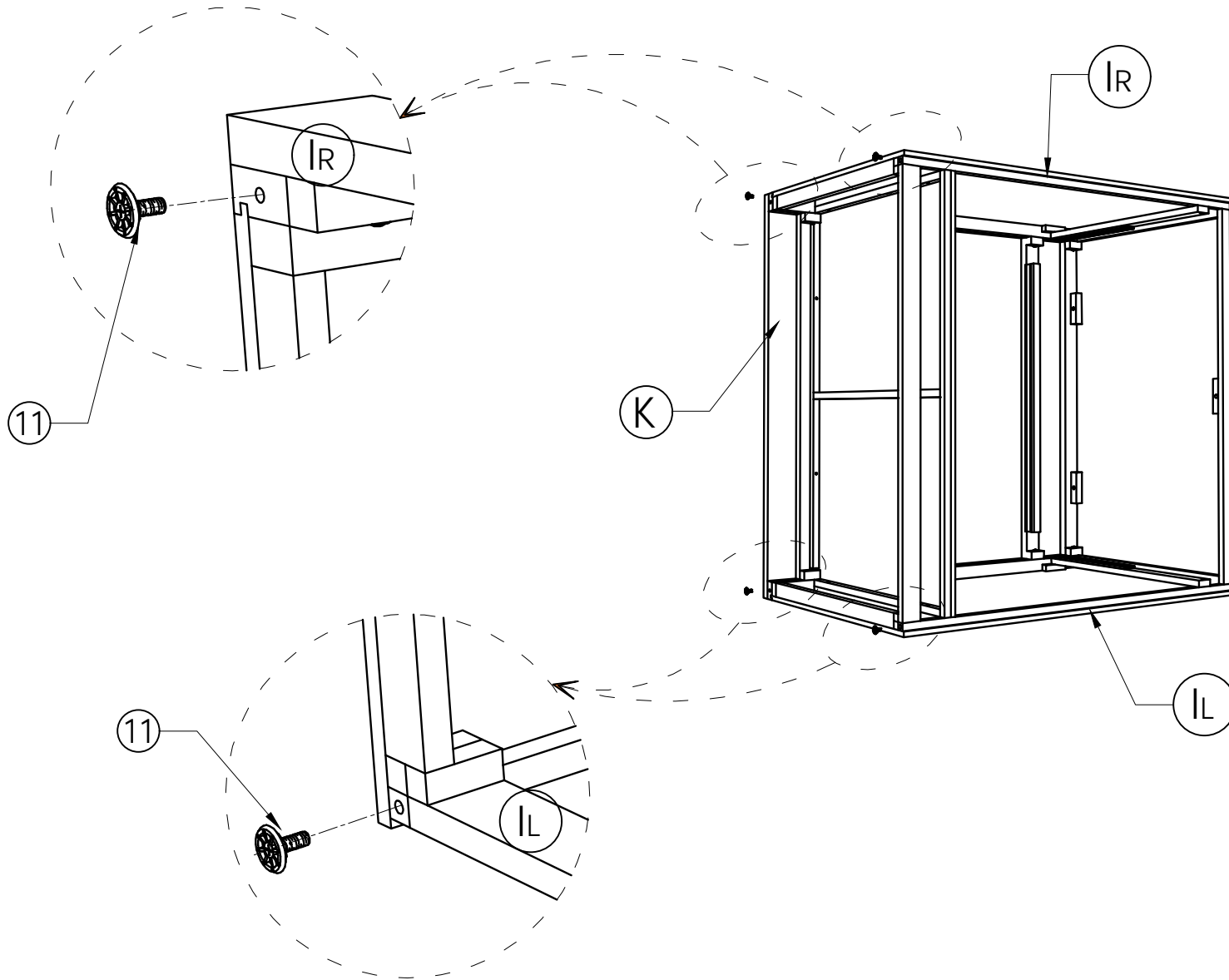

# STEP 14

1



1 pc

3



6x30mm  
7 pcs

4



6x16mm  
7 pcs

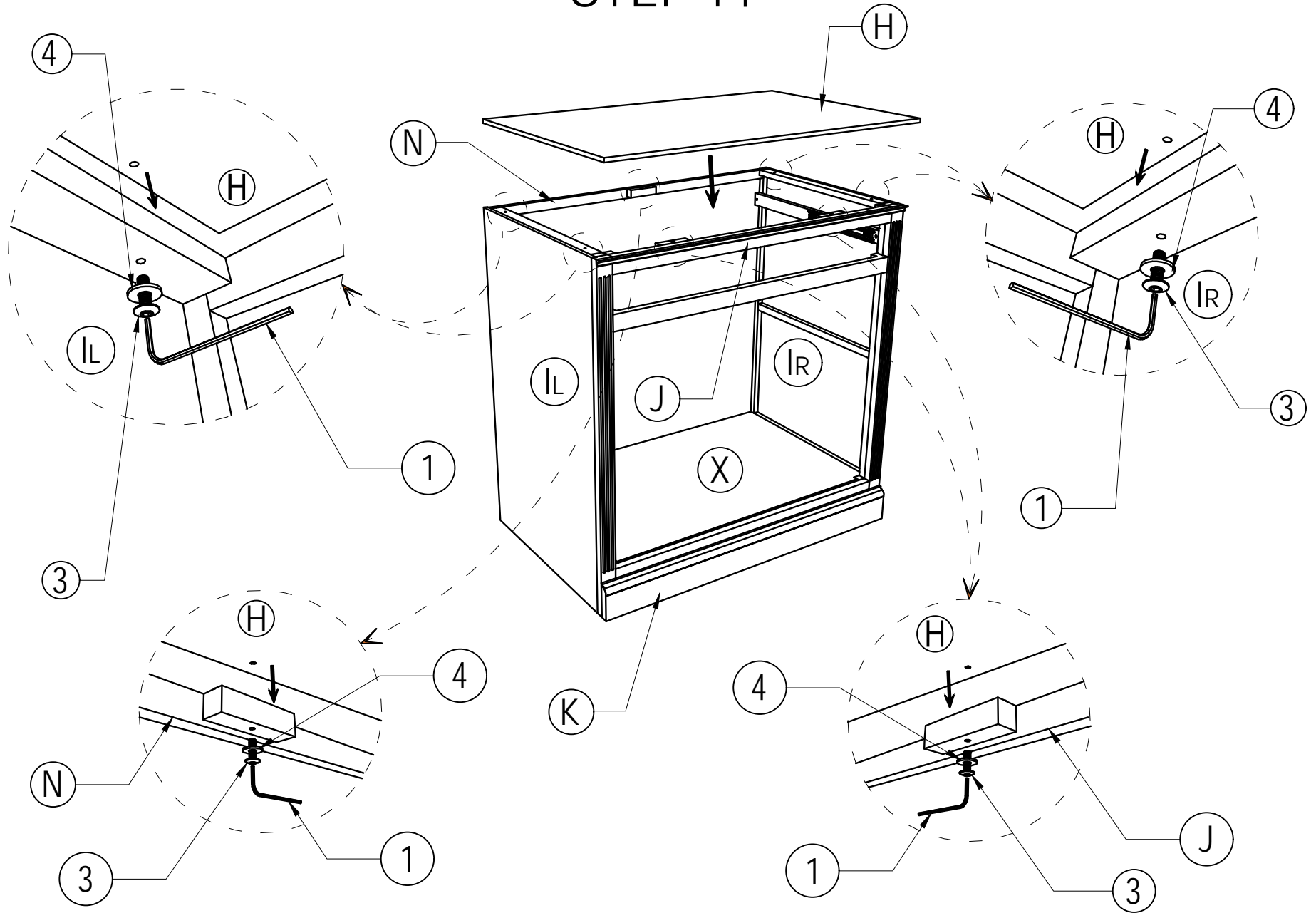

# STEP 15

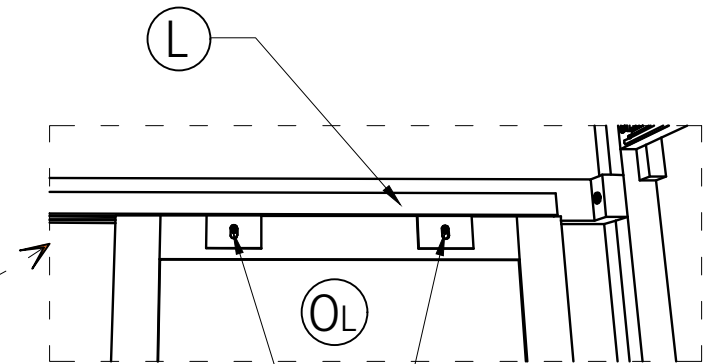
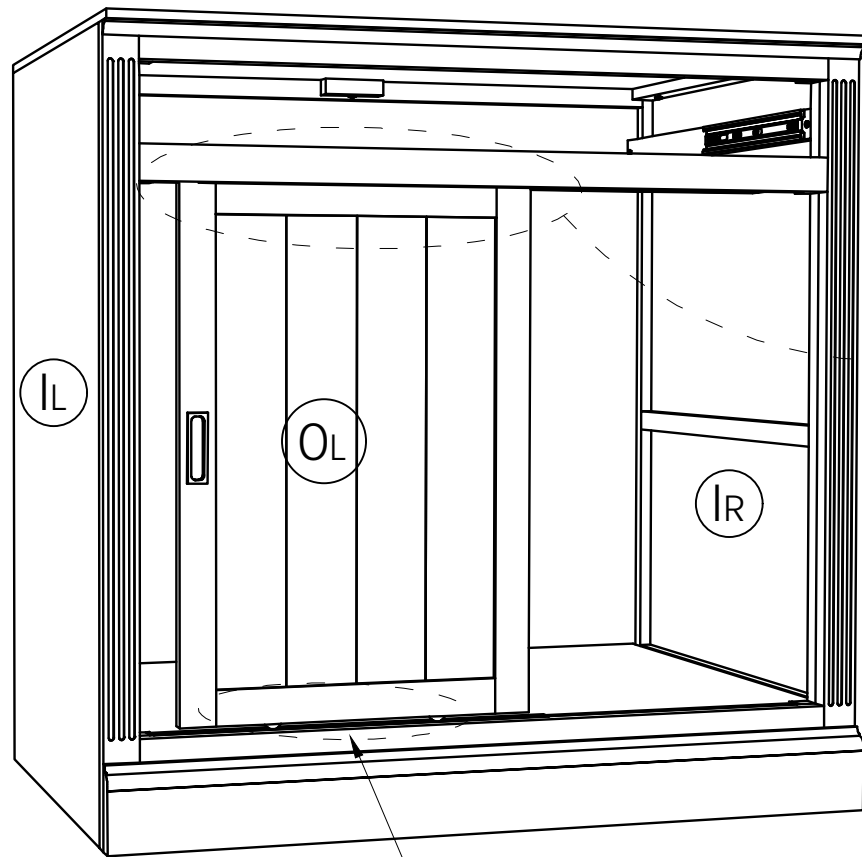

TURN ON THE BUTTON

PLACED ON THE INSIDE RAIL

# STEP 16

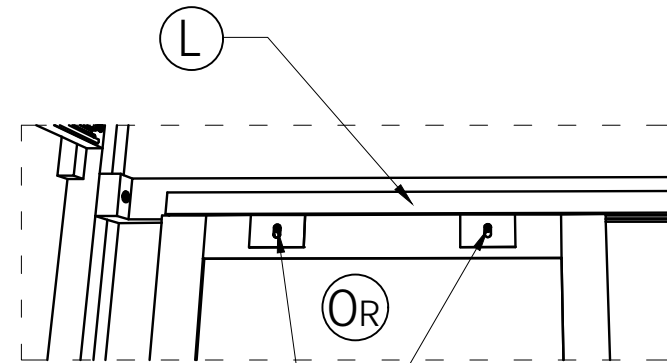
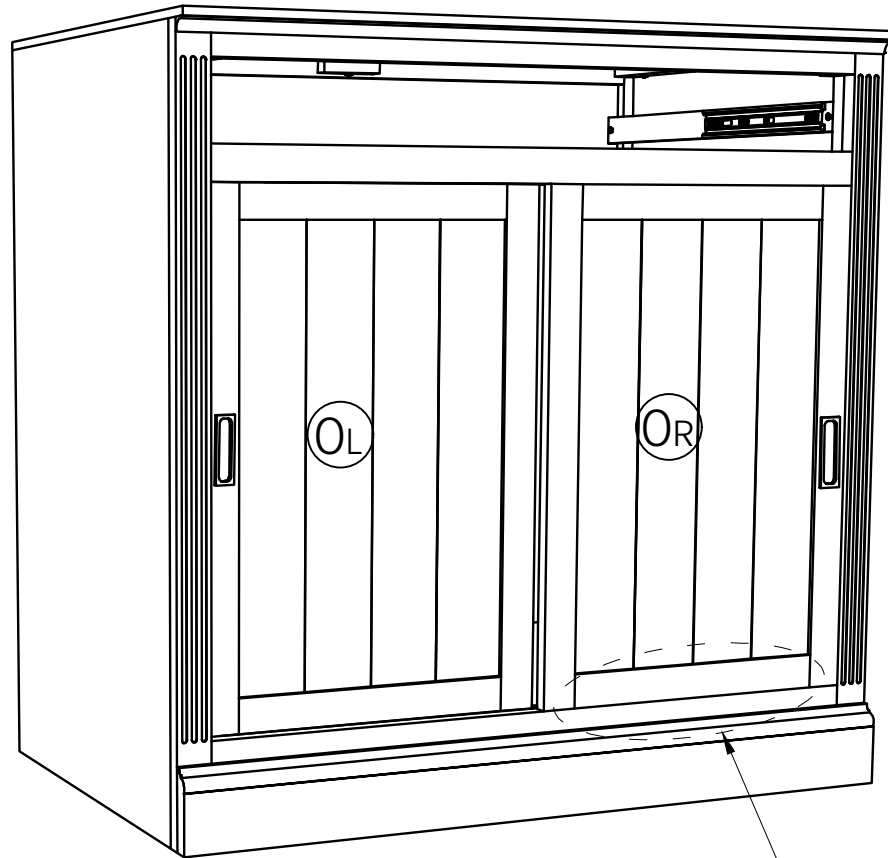

TURN ON THE BUTTON

PLACED ON THE OUTSIDE RAIL

# STEP 17



14

4x25mm  
4 pcs



10

1 pc

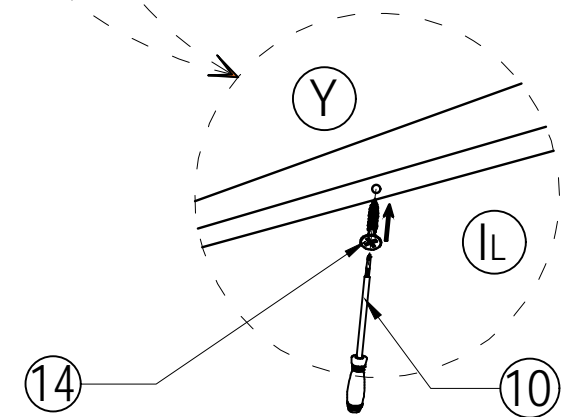
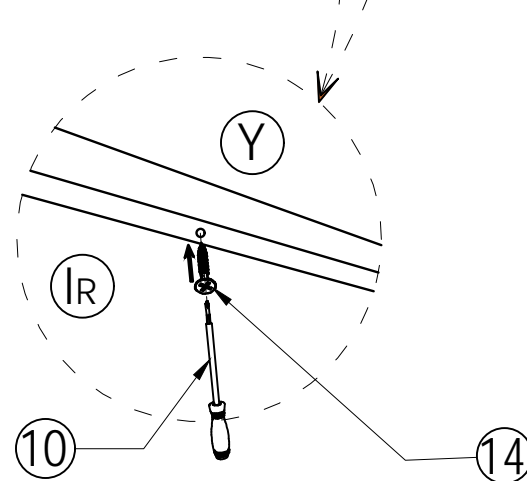
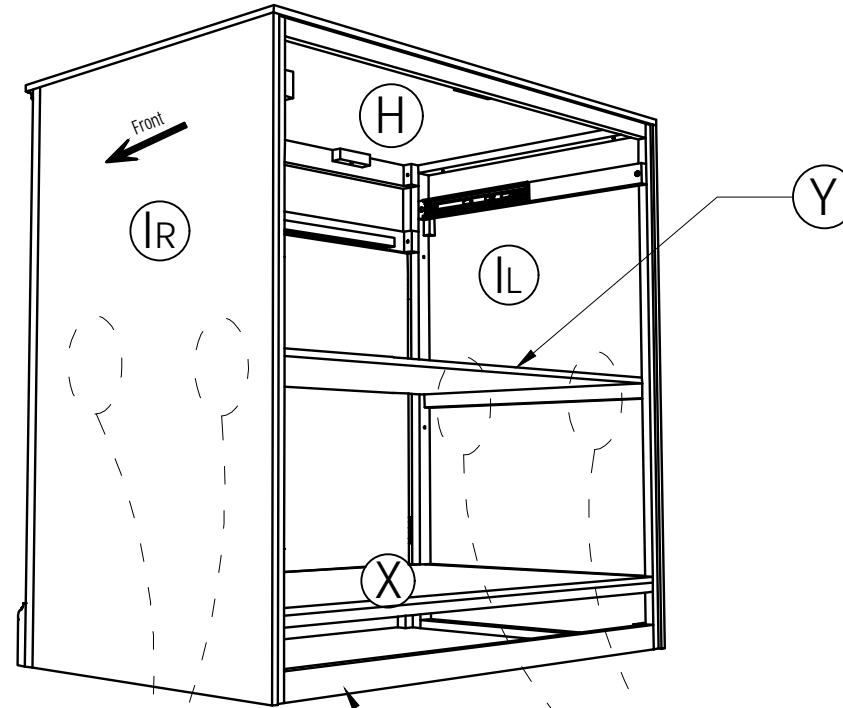

# Typical way to install cam screws

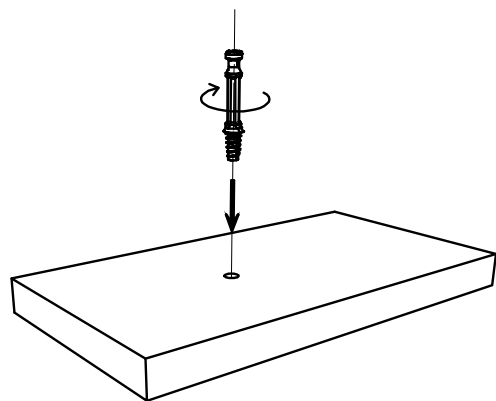

1

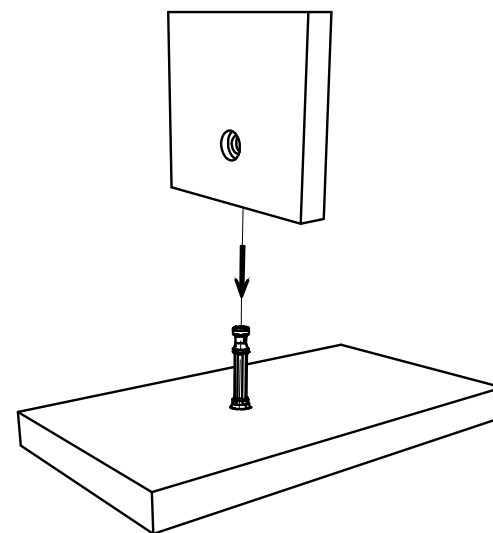

2

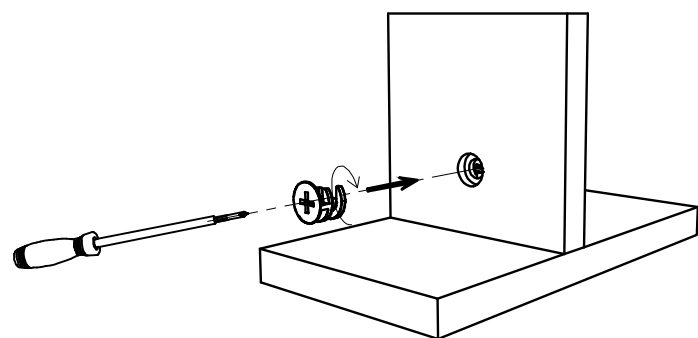

3

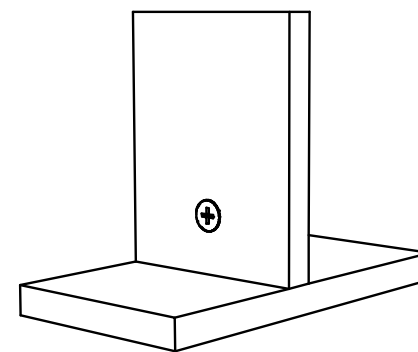

4. Done

# STEP 18

2



3 pcs

10



1 pc

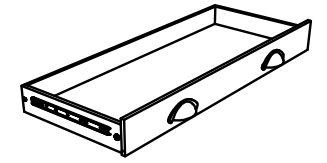

DRAWER

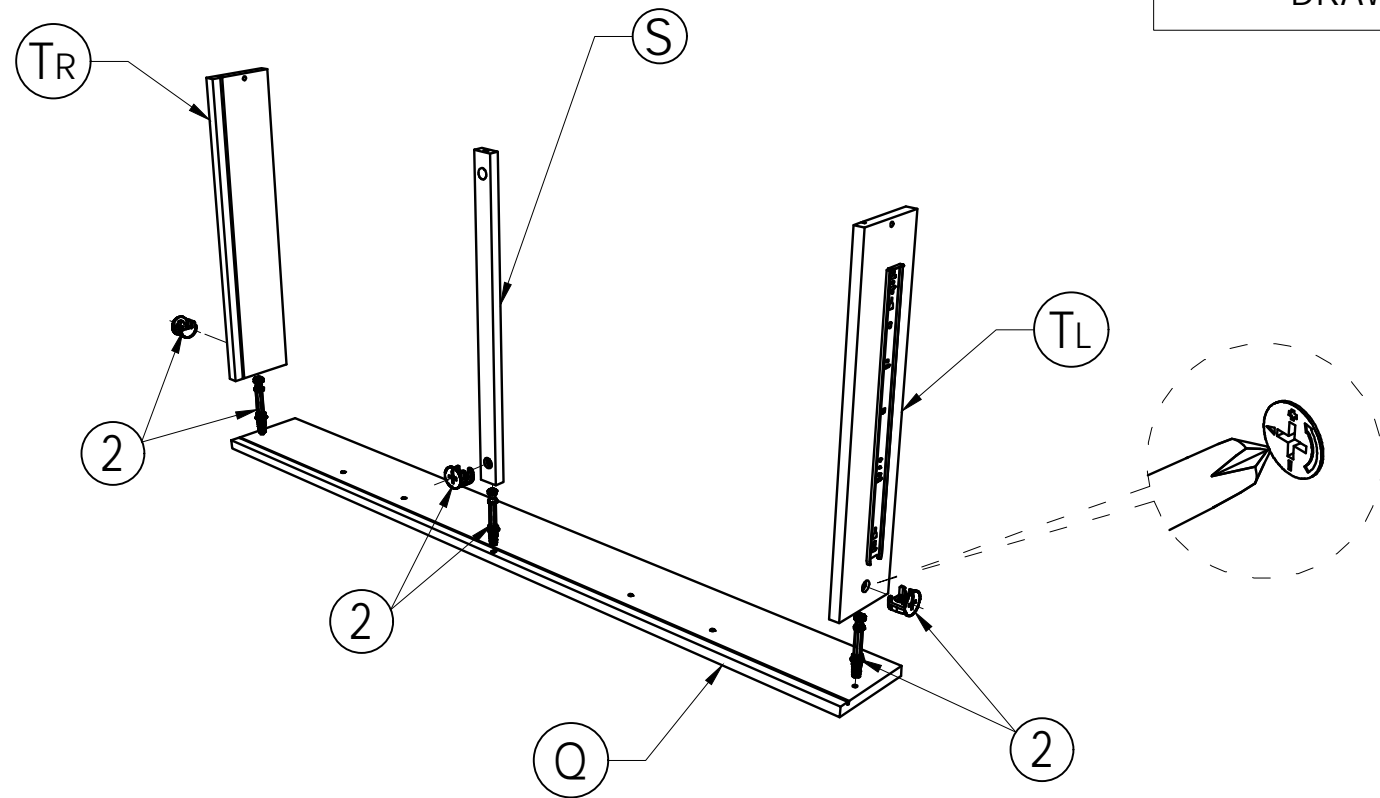

# STEP 19

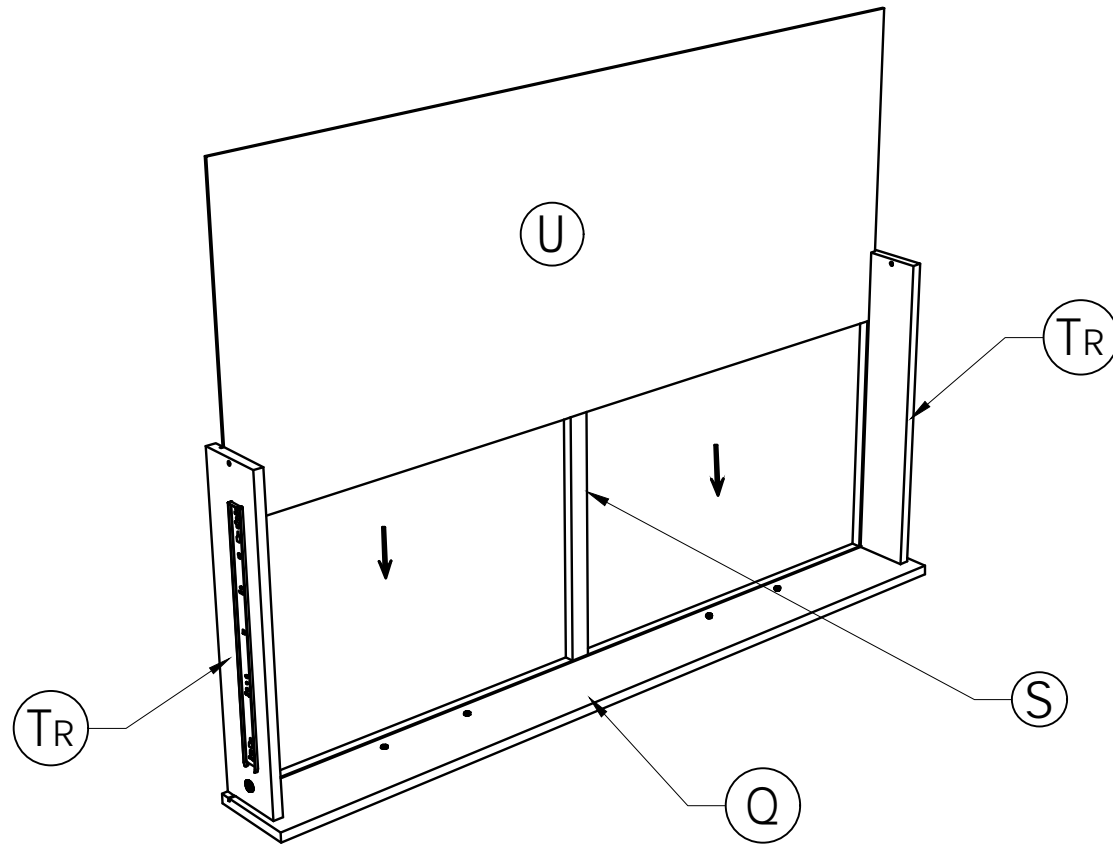

# STEP 20

2



1 pc

7



4x30mm  
2 pcs

10



1 pc

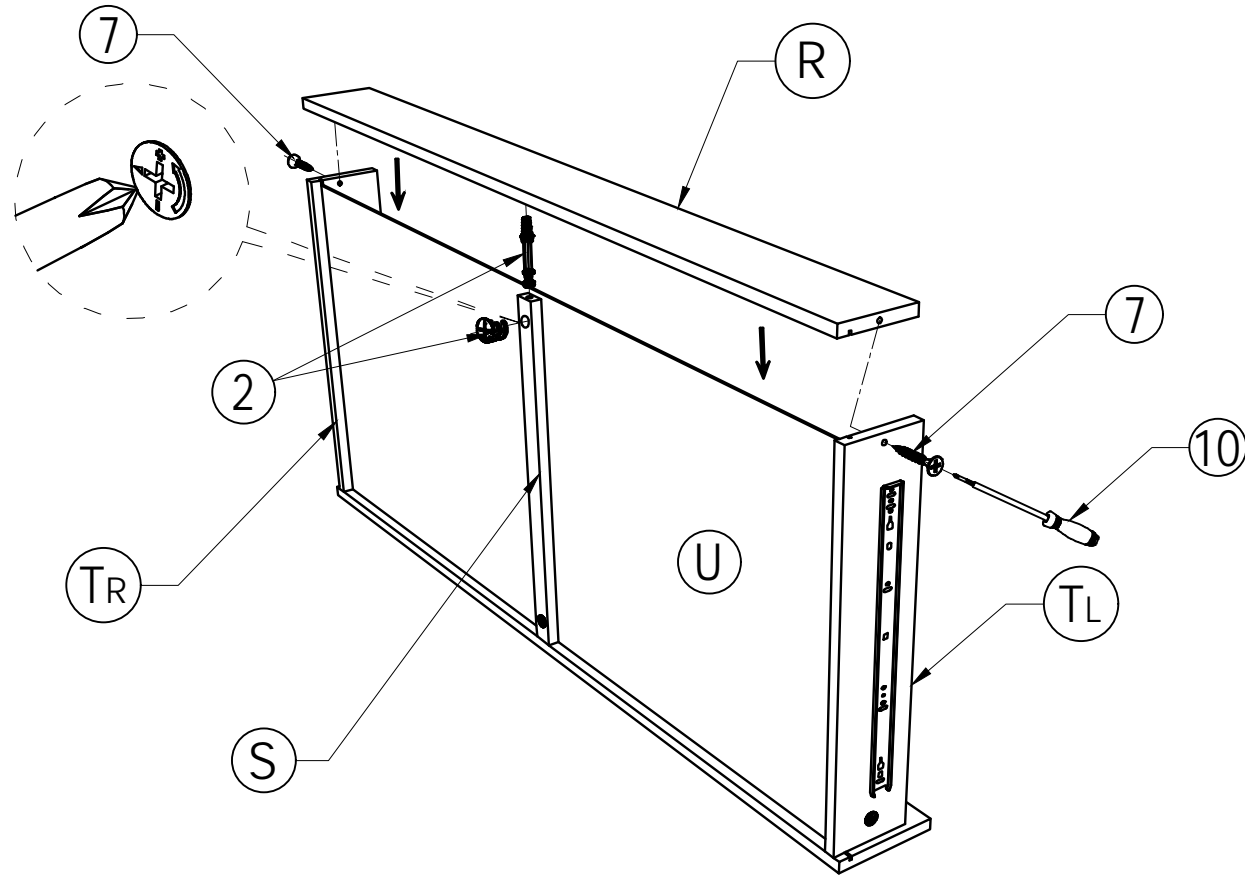

5



5x15mm  
4 pcs

9



2 pcs

# STEP 21

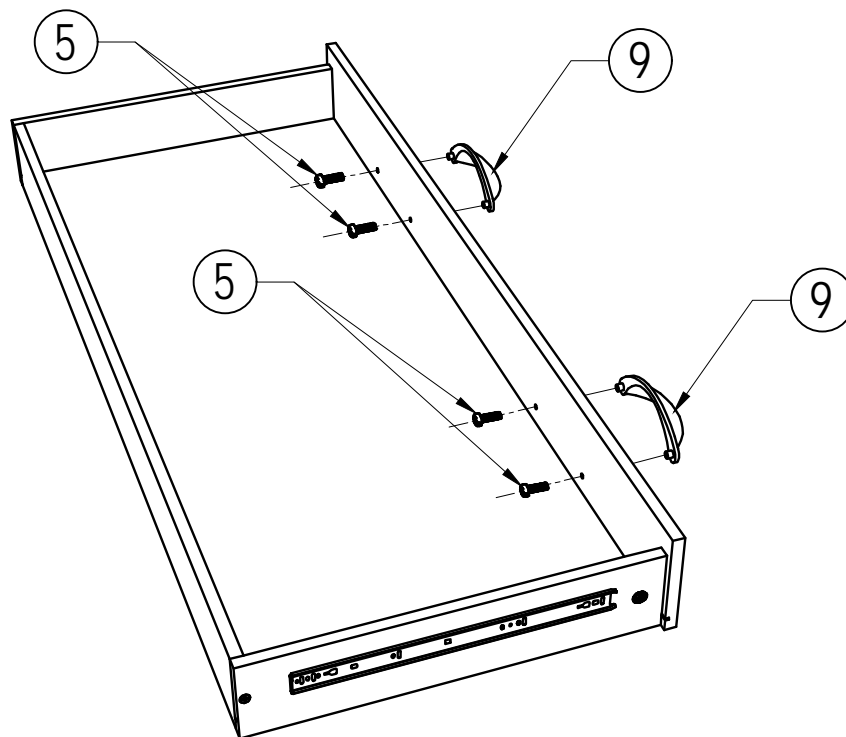

# STEP 22

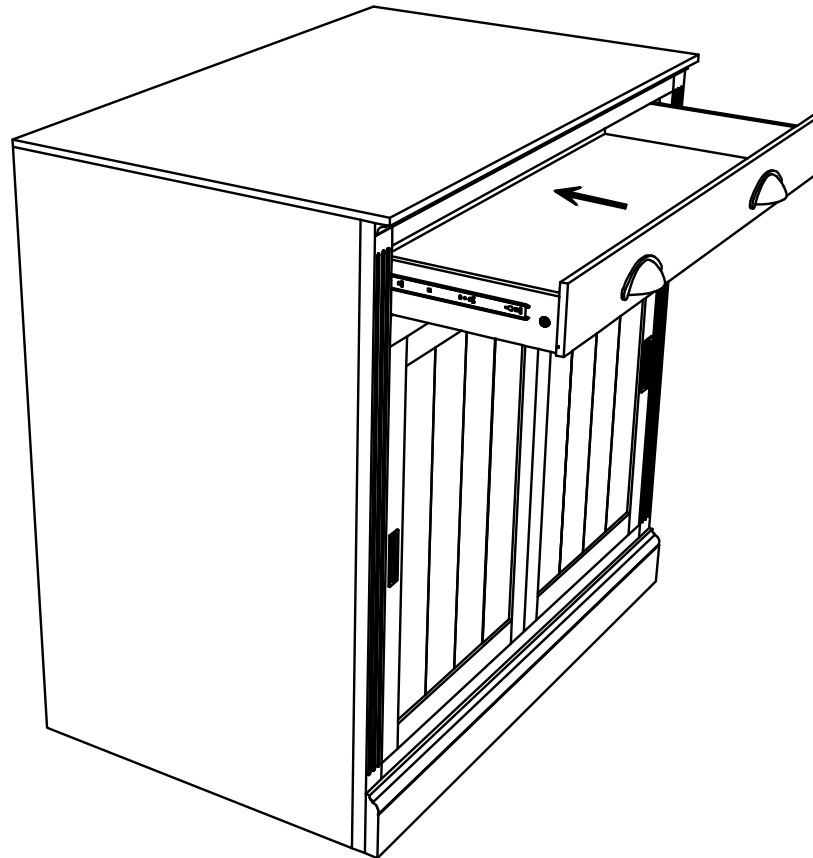

# STEP 23

8



3x15mm  
22 pcs

10



1 pc

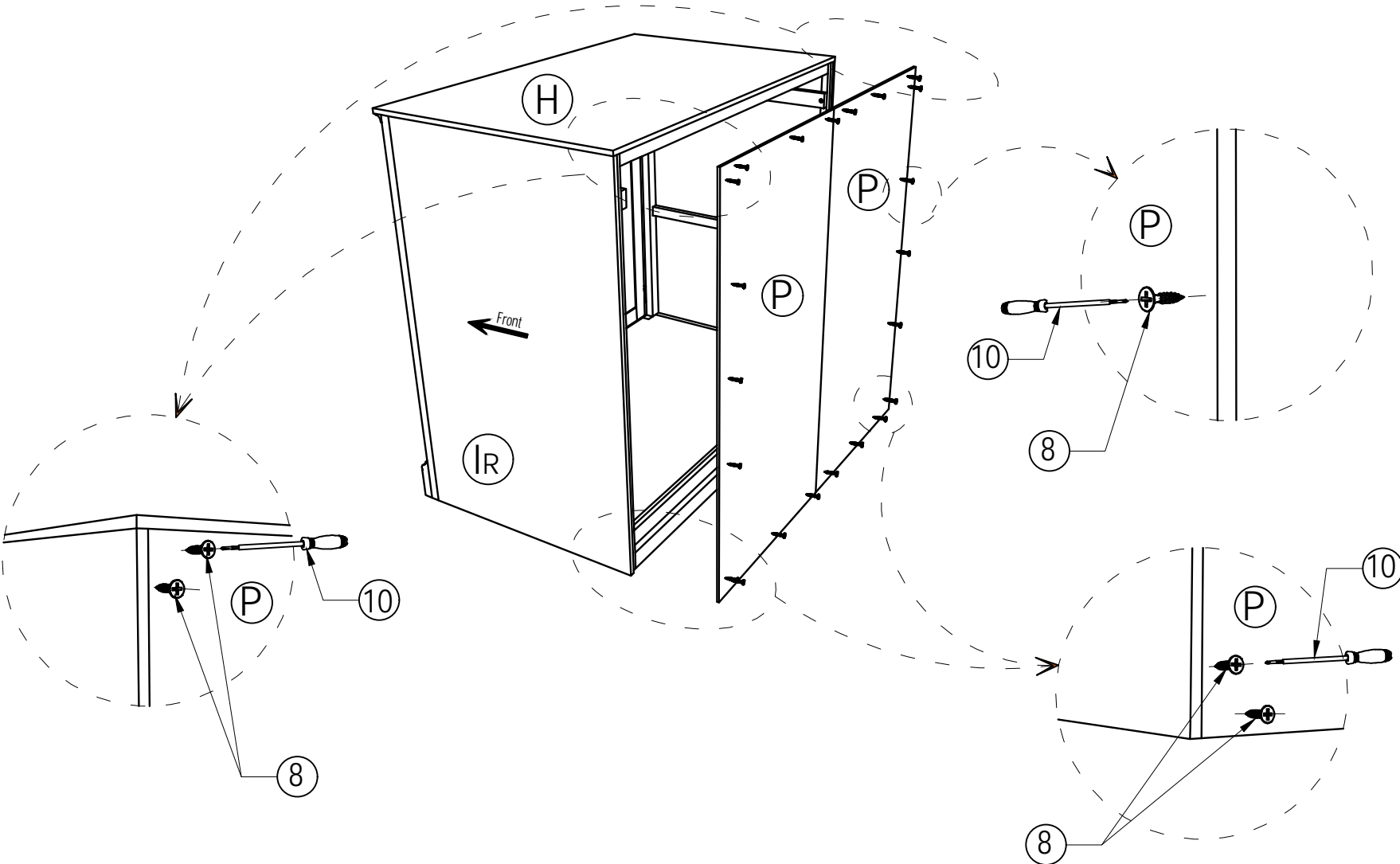

# STEP 24

12



20x80mm  
2 pcs

13



4x20mm  
4 pcs

10

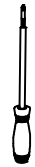

1 pc

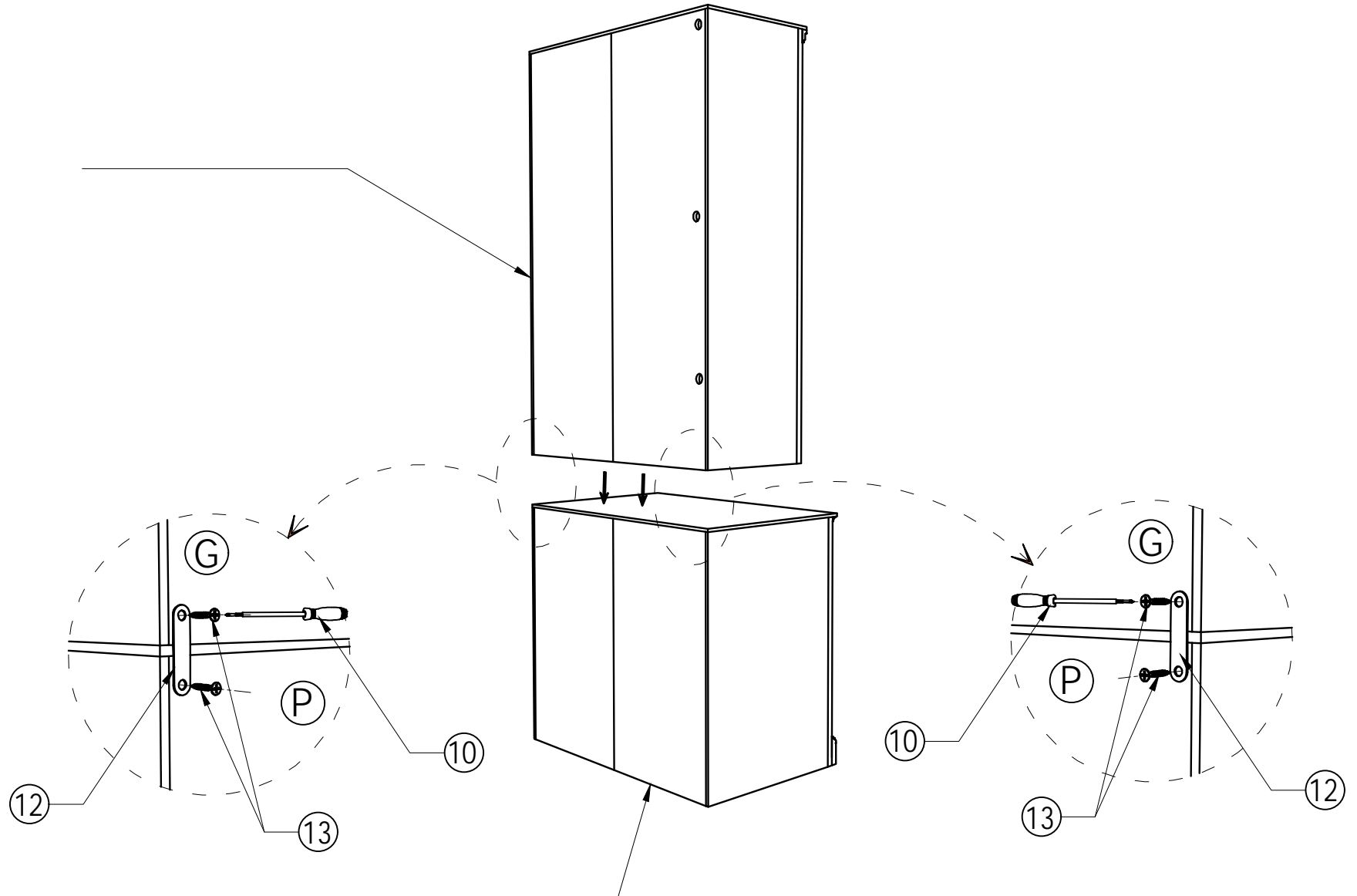

16

# STEP 25

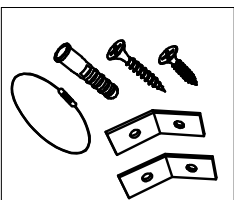

2 SET

