

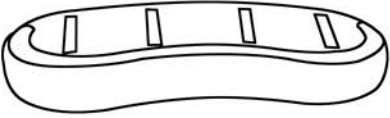





Assembly Instruction

Parts List

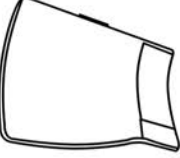
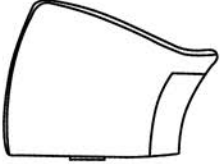
NO	Picture	Description	QTY
A		Seat base frame	1PC
B		Seat back frame	1PC
C		Seat back frame	1PC
D		Seat back frame	1PC
E		Seat Cushion	1PC
F		Back Cushion	2PCS
G		Pillow	1PC
J		Leg	4PCS

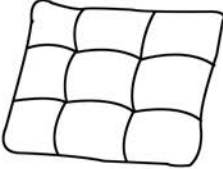
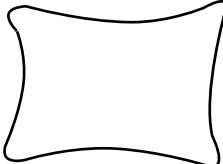
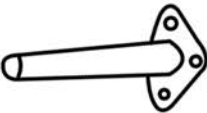
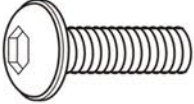
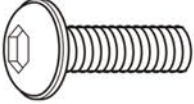
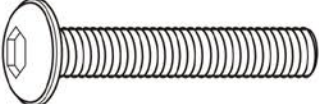
NO	Picture	Description	QTY
H1		M6x18mm Screw	12PCS
H2		M6x25mm Screw	4PCS
H3		M6x45mm Screw	6PCS
H4		Φ18mm Washer	4PCS
H5		Φ25mm Washer	6PCS
H6		Angle Iron	2PCS
H7		M5 Allen Wrench	1PC

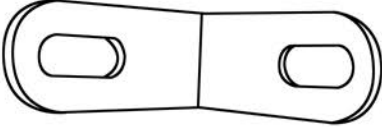
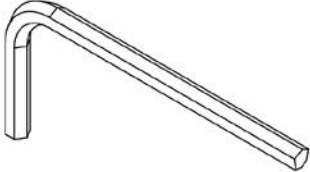
- 1 Connect the part(C) & part(D) to the part(B) as shown.

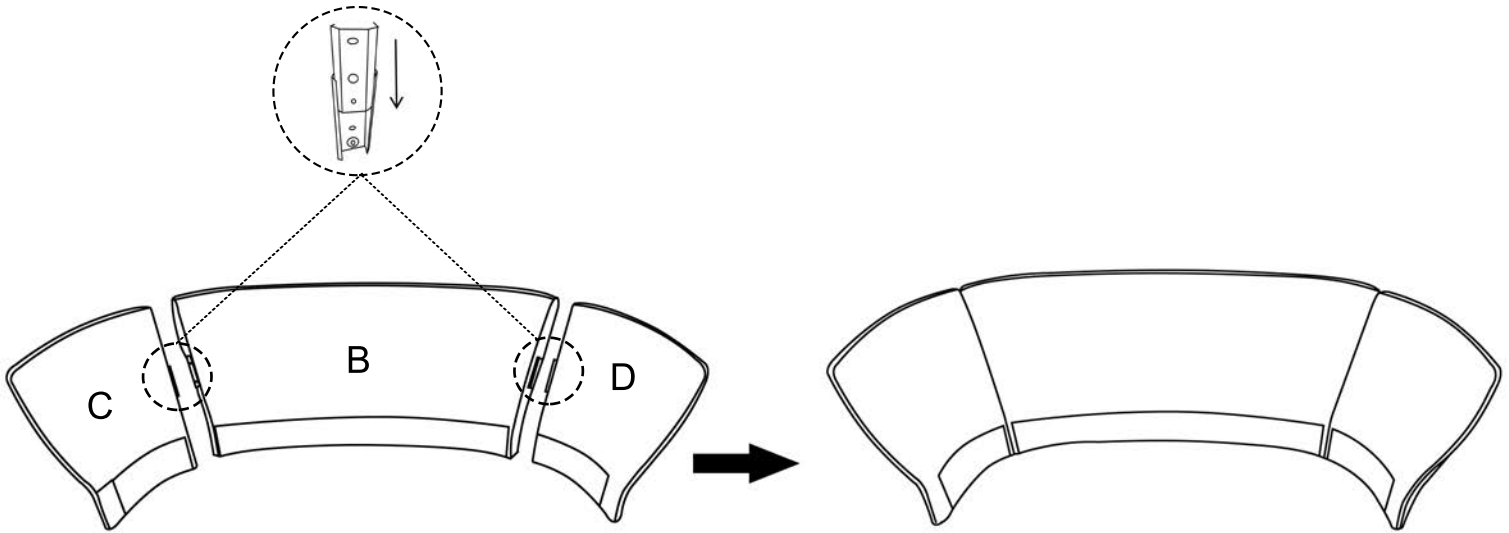

- 2 Attach the Chair Base (A) to the assembly from step 1, using Bolts (H3) and Flat Washers (H5). **Note:** Loosely attach the bolts one by one and keep them loose. Do not fully tighten. After all 6 bolts are attached, use Allen Wrench(H7) to tighten.

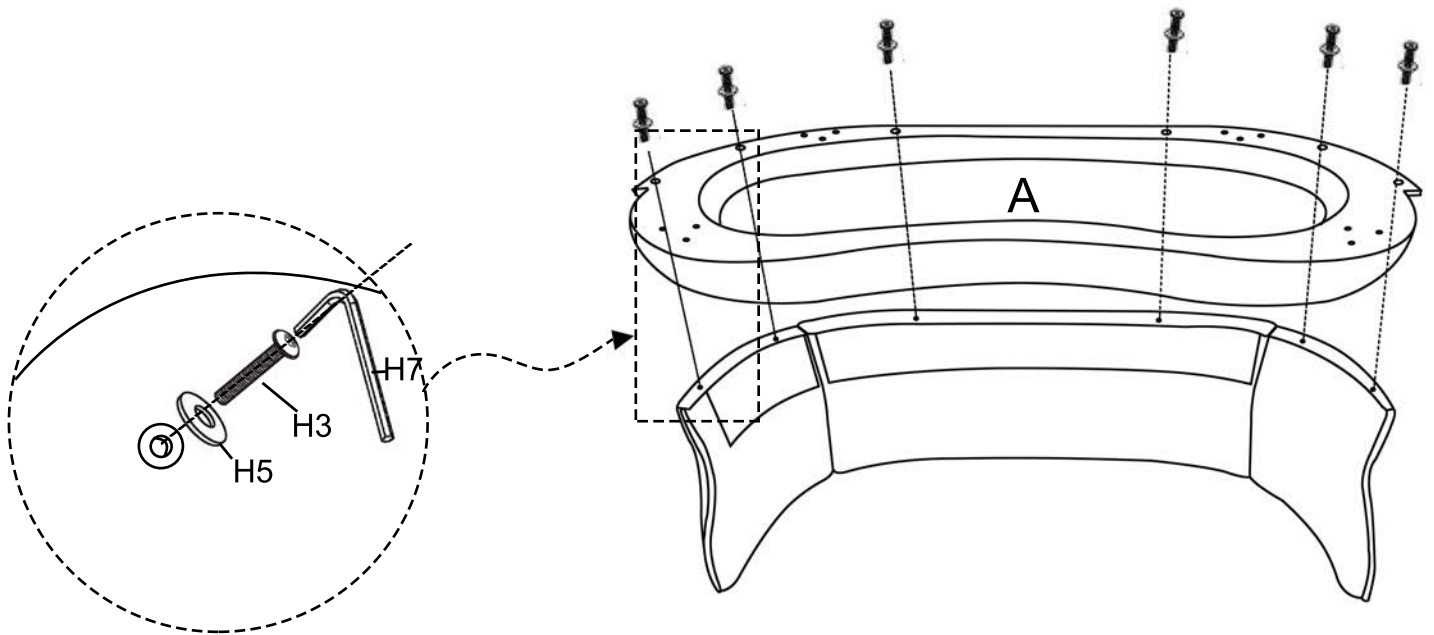

- 3** Attach the metal leg(J) to the assembly from step 2 using Bolts(H1) tighten with the M5 Allen Wrench(H7).

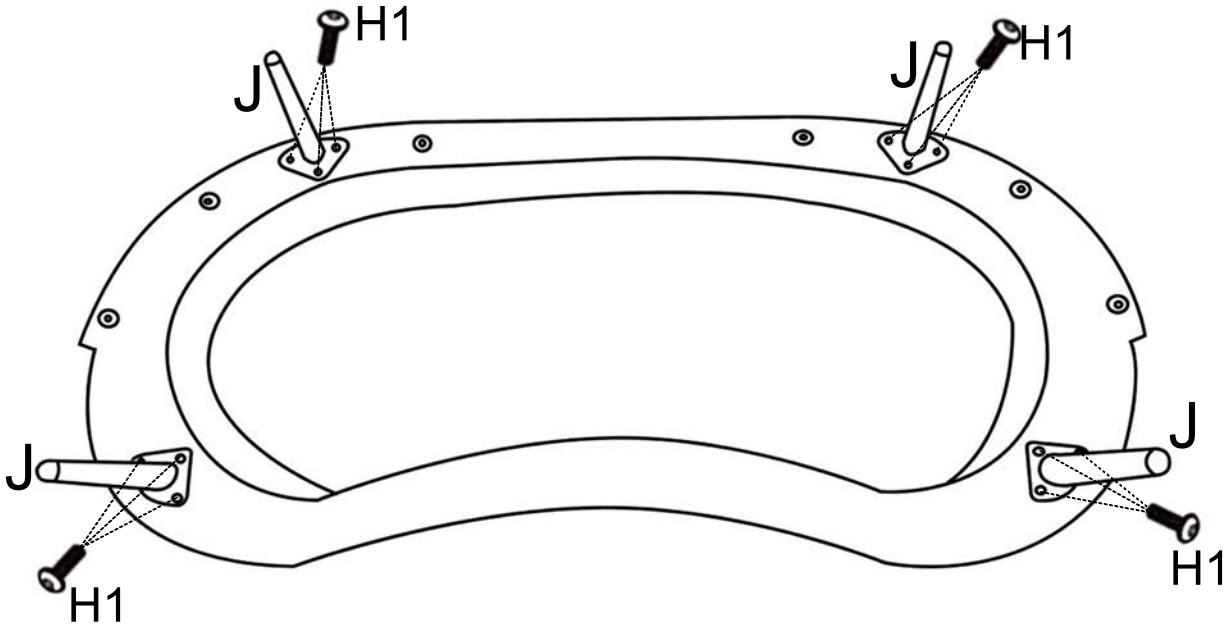

- 4** As shown in the figure, First, place the Angle Iron(H6) in the correct position, and install with M6x25mm screws (H2) and Flat Washers (H4), tighten with the M5 Allen Wrench(H7).NOTE:DO NOT TIGHTEN ONE BY ONE,After all screws find the corresponding holes then please twist 100%.

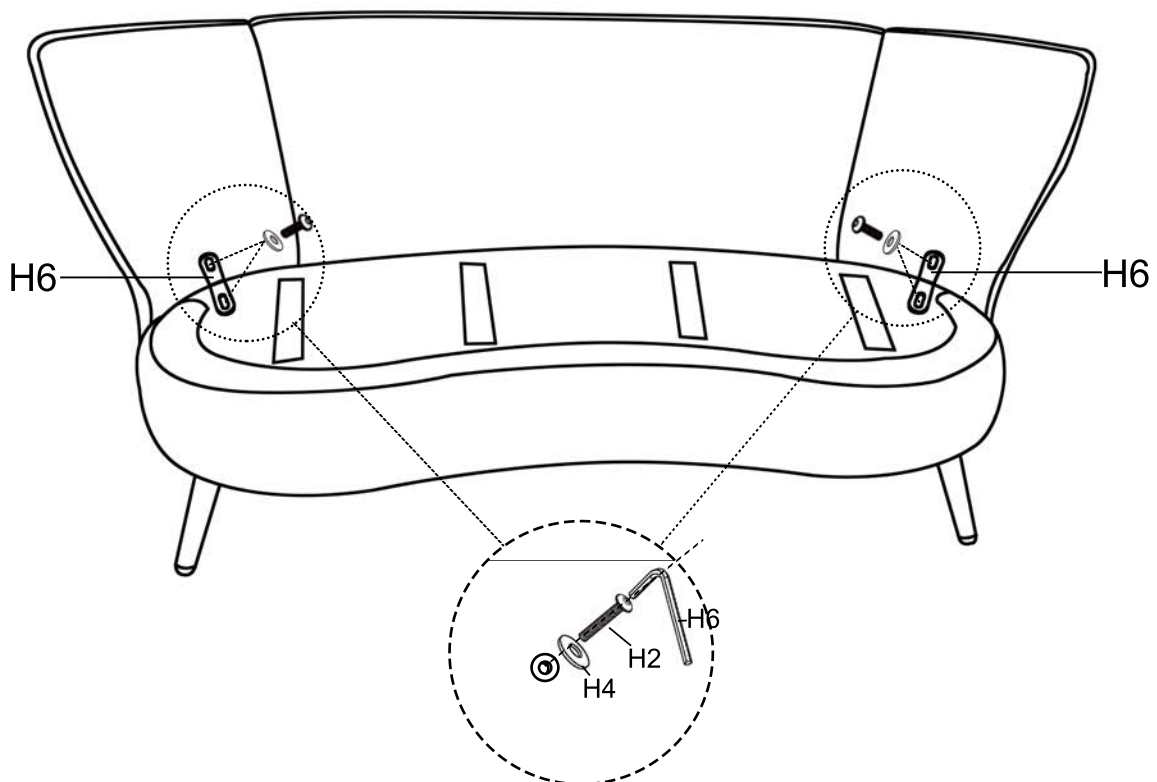

- 5** Cut the vacuum packaging, Pat around evenly plump, The compressed sponge will swelled up in 72 hours.

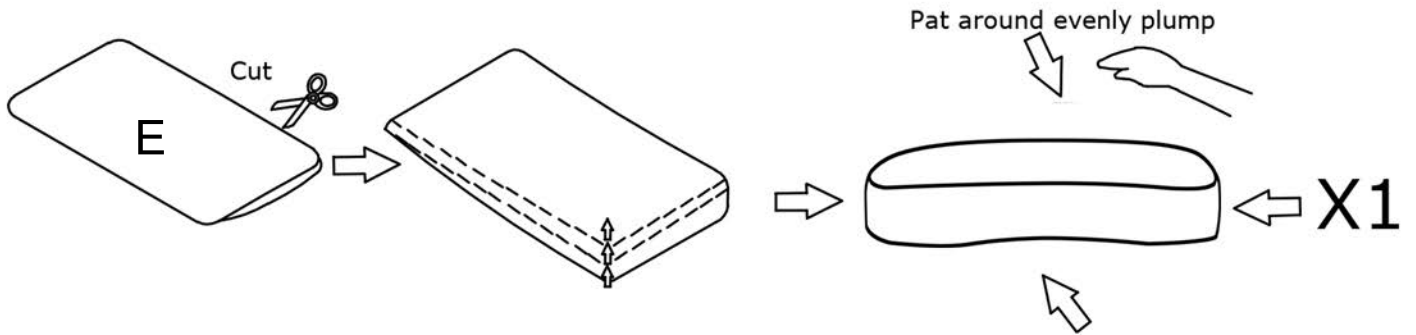

- 6** Tear off the Velcro protective cloth, Attach the Seat Cushion from step 5 into the Seat base then Lay the back cushion and pillow on the seat back as shown.

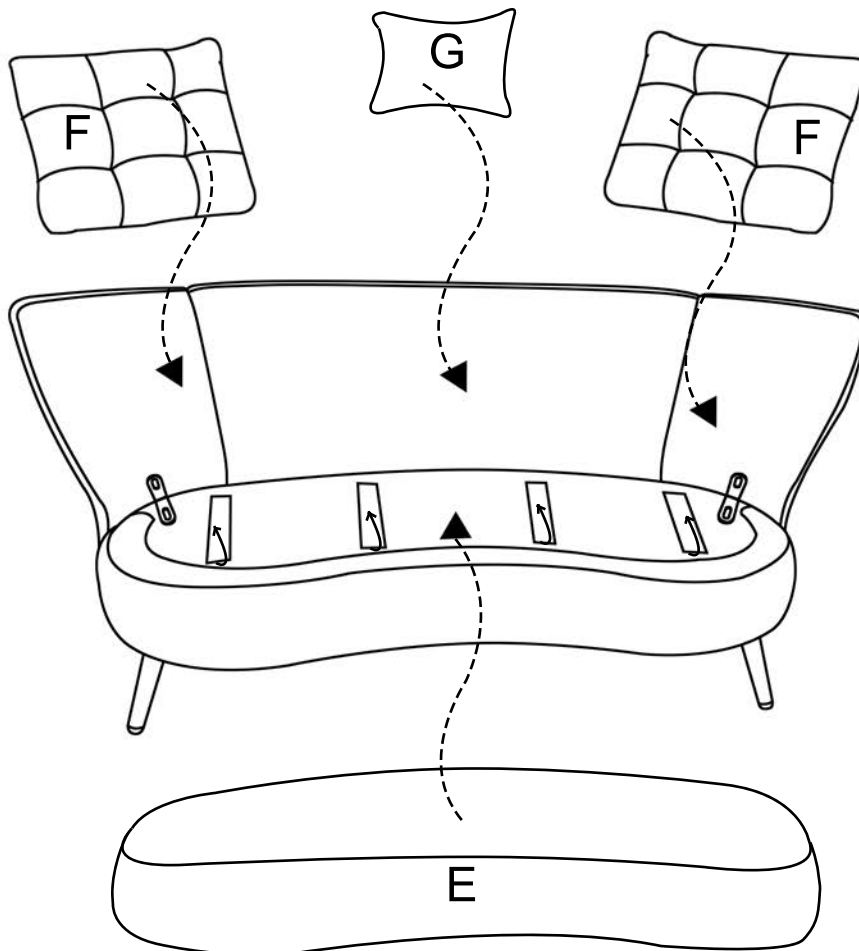

7 Assembly complete, enjoy it.

