









HARDWARE LIST

A		Bolt	Ø5/16"*3-1/2"	4 PCS
B		Bolt	Ø5/16"*1-3/4"	2 PCS
C		Nut	Ø5/16"	4 PCS
D		Lock Washer	Ø5/16"	10 PCS
E		Flat Washer	Ø5/16"*19D	10 PCS
F		Allen Key	100*50*4mm	1 PC
G		Spanner Wrench	12MM	1 PC
H		Screw	Ø8*1-3/4"	4 PCS

PART LIST

1	Chair Back	1 PC
2	Seat Frame + Wood Seat	1 PC
3	Left Front Leg	1 PC
4	Right Front Leg	1 PC
5	Stretcher Frame	1 PC
6	Seat Cushion	1 PC

IMPORTANT NOTES

- . Place all wooden parts on clean and smooth surface such as rug or carpet to prevent the parts from being scratched.
- . Check to be sure that you have all parts and hardware.
- . Remove all wrapping materials, including staples and packing straps before you start to assemble.
- . Do not tighten all screws and bolts until completely assembled.
- . Keep all hardware out of the reach of children

Option 1

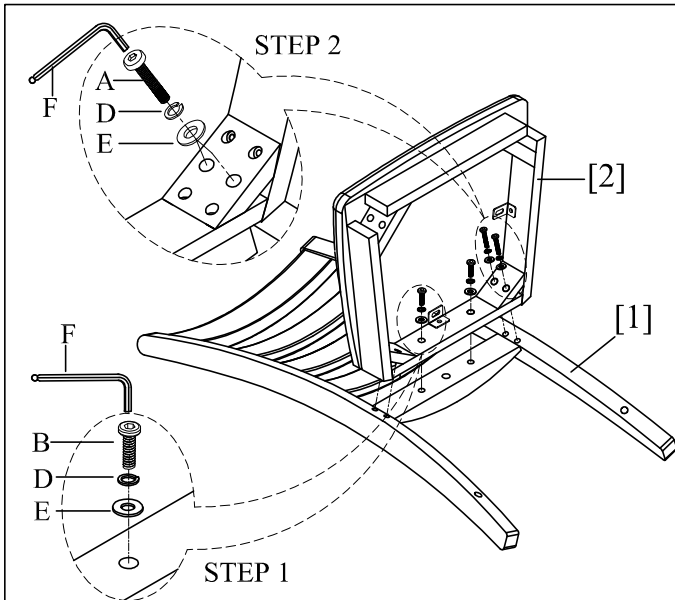

STEP 1. Place chair back (1) on a clean & padded surface then attach seat frame + wood seat (2) to the chair back using bolt (B), lock washer (D), flat washer (E), and tighten with allen key (F). Important: Do not over-tighten.

STEP 2. Attach back assembly to the seat frame + wood seat (2) using bolt (A), lock washer (D), flat washer (E), and tighten with allen key (F). Important: Do not over-tighten.

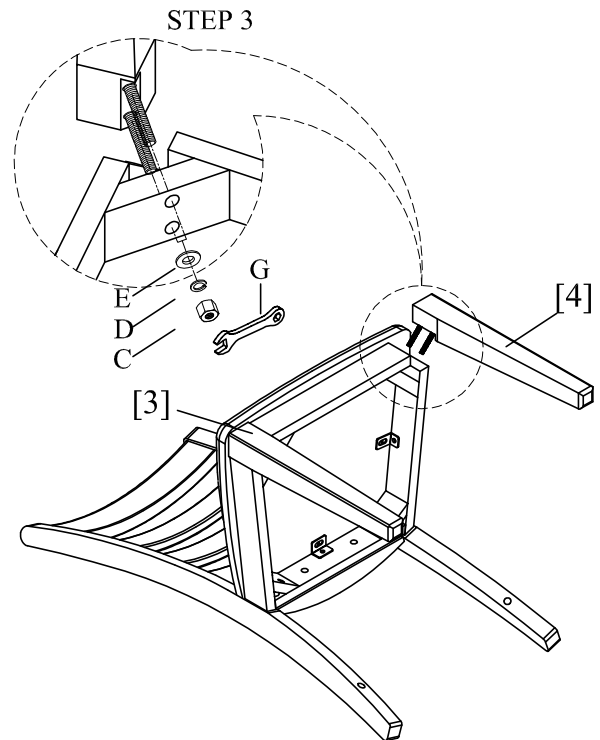

STEP 3 .Attach the left front leg (3) and right front leg (4) to the seat frame + wood seat (2) using nut (C), lock washer (D), flat washer (E), and tighten with spanner wrench (G). Important: Do not over-tighten.

Option 1

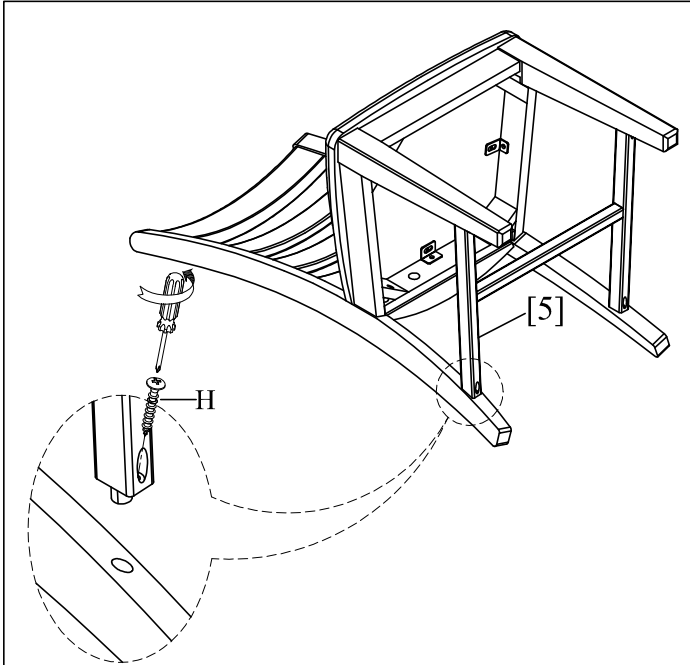

STEP 4. Attach the stretcher frame (5) to the back and front legs with screw (H) and tighten with screwdriver .
Important: Do not over-tighten

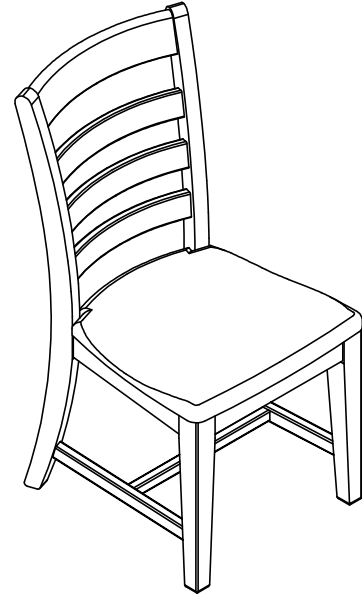

STEP 5. To ensure chair is stable, tighten bolts (A,B), using the allen key (F), tighten nuts (C) using spanner wrench (G), tighten screw (H) using the screwdriver while applying downward pressure to the seat.

Option 2

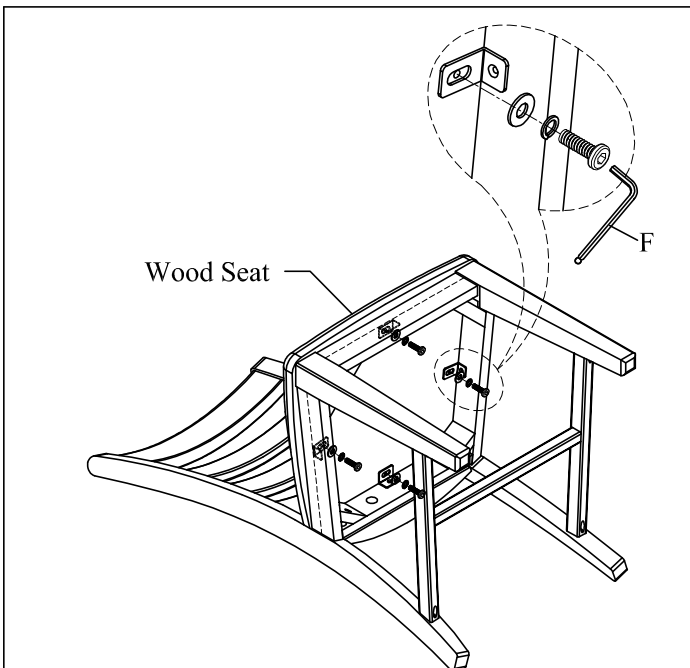

STEP 6. Unbolt bolt, lock washer and flat washer by allen key (F) and keep them well for re-use in step 7.
Remove the wood seat.

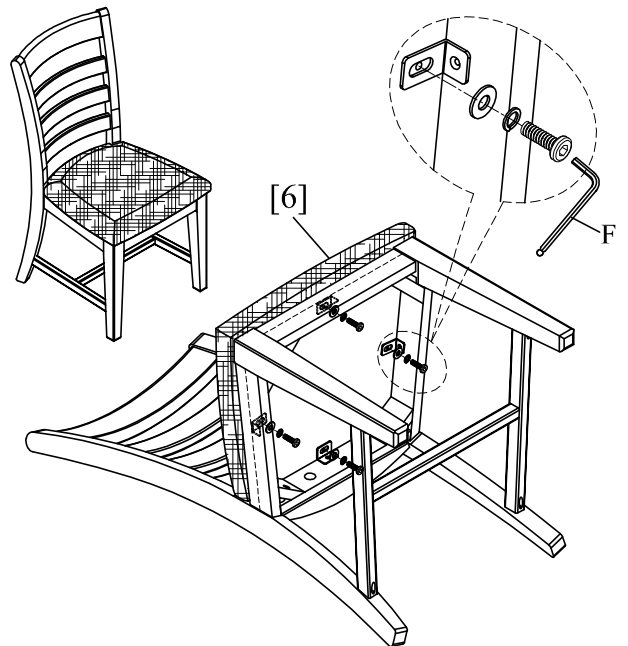

STEP 7. Assemble the seat cushion (6) to the seat frame by tighten bolts, lock washers , flat washers from step 6 with allen key (F).