

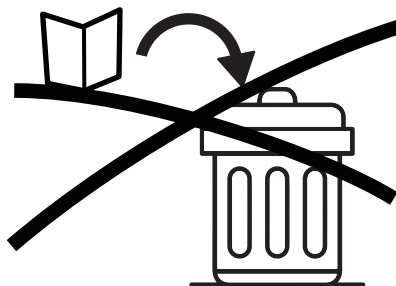

# **ASSEMBLY INSTRUCTIONS**

# NOTICE

IMPORTANT, RETAIN FOR FUTURE REFERENCE: READ CAREFULLY  
WICHTIG, FÜR SPÄTERE NACHSCHLAGE AUFBEWAHREN: SORGFÄLTIG LESEN  
IMPORTANTE, GUARDAR PARA REFERENCIA POSTERIOR: LEER ATENTAMENTE  
IMPORTANTE, CONSERVARE PER RIFERIMENTI FUTURI: LEGGERE ATTENTAMENTE  
IMPORTANT, À CONSERVER POUR RÉFÉRENCE FUTURE : LIRE ATTENTIVEMENT

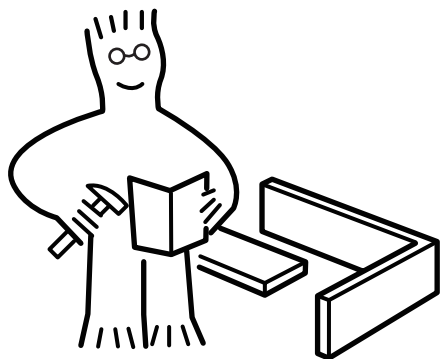

Assemble on a flat, clean and soft surface.

Auf einer flachen, sauberen und weichen Oberfläche zusammenbauen.

Assembler sur une surface plate, propre et douce.

Assemblare su una superficie piatta, pulita e morbida.

Ensamblar sobre una superficie plana, limpia y suave.

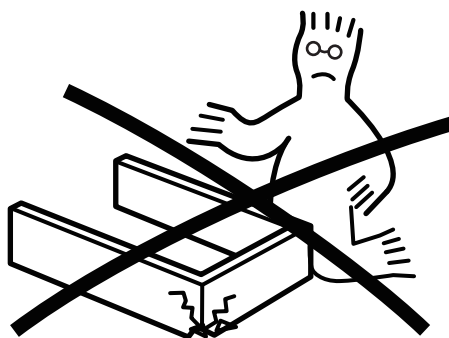
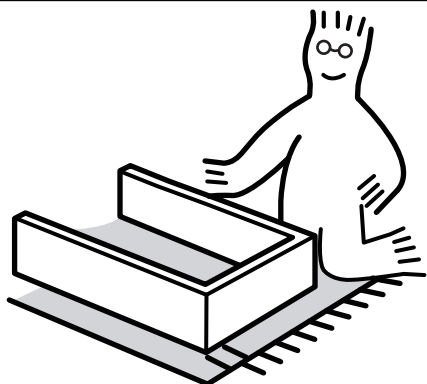

Professional installation is highly recommended.

Eine professionelle Installation wird dringend empfohlen.

Une installation professionnelle est fortement recommandée.

Si raccomanda vivamente l'installazione professionale.

Se recomienda altamente la instalación profesional.



Periodically check that all components are tightly secured.

Überprüfen Sie Regelmäßig, Dass Alle Komponenten Fest Gesichert Sind.

Vérifiez Périodiquement Que Tous Les Composants Sont Bien Fixés.

Controllare Periodicamente Che Tutti I Componenti Siano Ben Fissati.

Verifique Periódicamente Que Todos Los Componentes Estén Bien Asegurados.

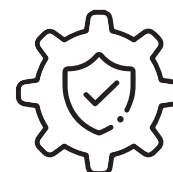

It is recommended that multiple people assemble this product.

Es wird empfohlen, dass mehrere Personen dieses Produkt zusammenbauen.

Il est recommandé que plusieurs personnes assemblent ce produit.

Si raccomanda che più persone assemblino questo prodotto.

Se recomienda que varias personas ensamblen este producto.

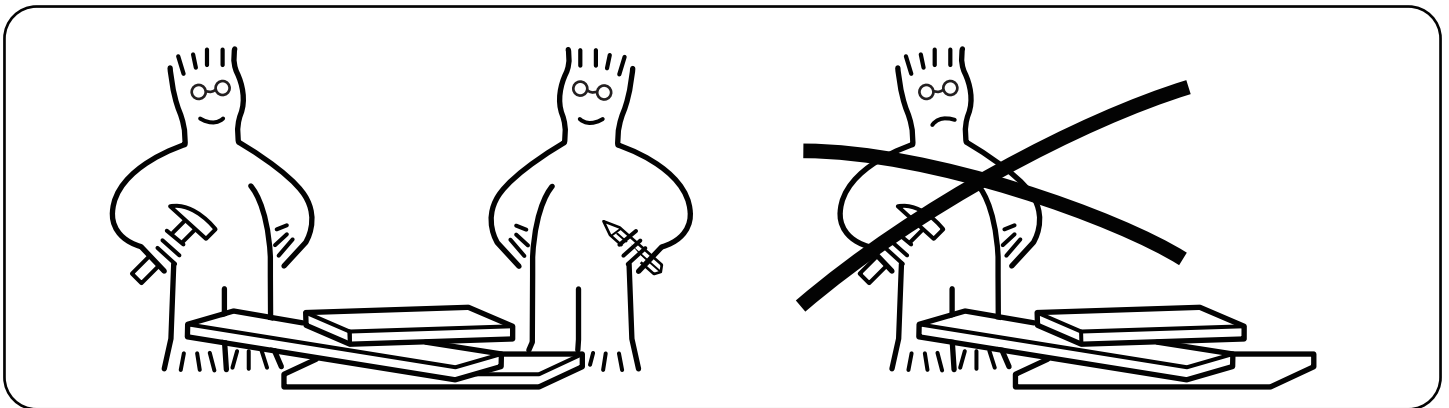

Serious or fatal crushing injuries can occur from furniture tip-over. Always secure this furniture to the wall using tip-over restraints.

Schwere oder tödliche Quetschverletzungen können durch das Umkippen von Möbeln verursacht werden. Sichern Sie diese Möbel immer mit Kipp-Sicherungen an der Wand.

Des blessures graves ou mortelles par écrasement peuvent survenir en cas de basculement de meubles. Fixez toujours ces meubles au mur à l'aide de dispositifs anti-basculement.

Lesioni gravi o mortali da schiacciamento possono verificarsi a causa del ribaltamento dei mobili. Fissare sempre questi mobili alla parete utilizzando i sistemi di blocco anti-ribaltamento.

Pueden ocurrir lesiones graves o fatales por aplastamiento debido al volcamiento de muebles. Siempre asegure este mueble a la pared utilizando dispositivos anti-vuelco.

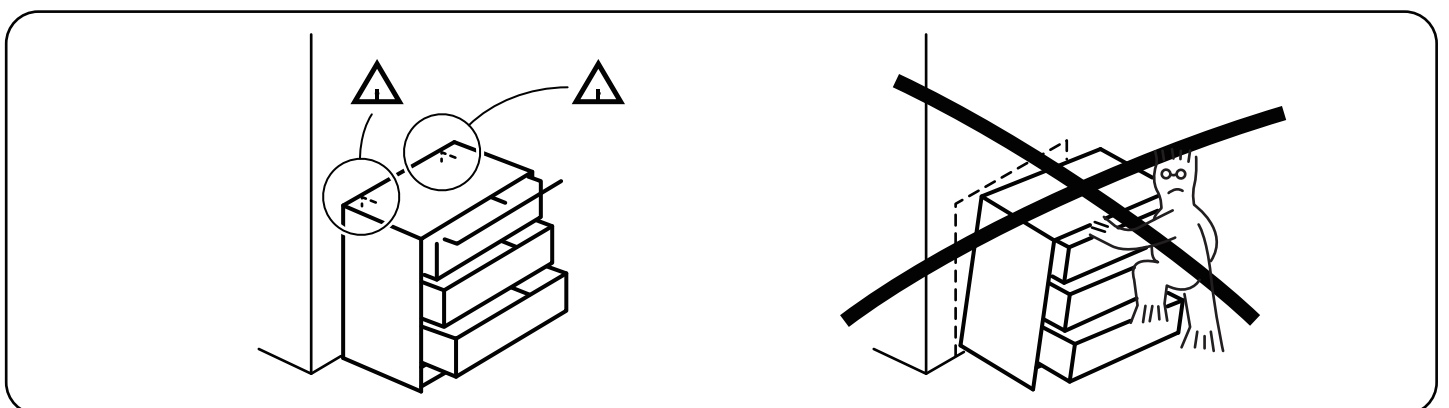

Please have the following auxiliary tools ready:

Bitte halten Sie folgende Hilfswerkzeuge bereit:

Veuillez préparer les outils auxiliaires suivants :

Si prega di avere pronti i seguenti strumenti ausiliari:

Por favor, tenga listas las siguientes herramientas auxiliares:

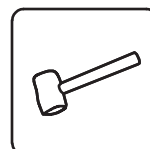
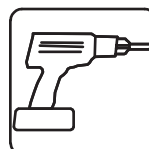

**USING CAM LOCK AND QUICKFIT**  
**VERWENDUNG VON NOCKENSCHLOSS UND QUICKFIT**  
**UTILISATION DE SERRURE À CAME ET QUICKFIT**  
**USO DI SERRATURA A LEVA E QUICKFIT**  
**USANDO EL CIERRE DE LEVA Y QUICKFIT**

Tighten QuickFit until the shoulder is flush with the panel. Do not overtighten or undertighten.  
 Ziehen Sie den Quickfit an, bis die Schulter bündig mit der Platte ist. Nicht zu fest oder zu locker anziehen.  
 Serrez le quickfit jusqu'à ce que l'épaulement soit affleurant avec le panneau. Ne serrez pas trop ou trop peu.  
 Stringere il quickfit fino a quando la spalla è a filo con il pannello. Non stringere troppo o troppo poco.  
 Apriete el quickfit hasta que el hombro esté al ras con el panel. No apriete demasiado ni demasiado poco.

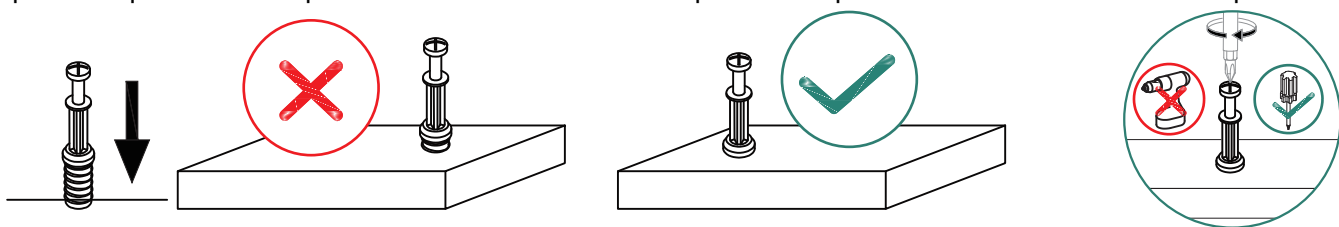

When fitting the cam lock, ensure the starting position is correct before inserting the connecting QuickFit.

Stellen Sie beim Einbau des Nockenschloss sicher, dass die Startposition korrekt ist, bevor Sie den verbindenden Quickfit einsetzen.

Lors de la pose du serrure à came, assurez-vous que la position de départ est correcte avant d'insérer le quickfit de connexion.

Quando si monta il serratura a leva, assicurarsi che la posizione di partenza sia corretta prima di inserire il quickfit di collegamento.

Al instalar el cierre de leva, asegúrese de que la posición inicial sea correcta antes de insertar el quickfit de conexión.

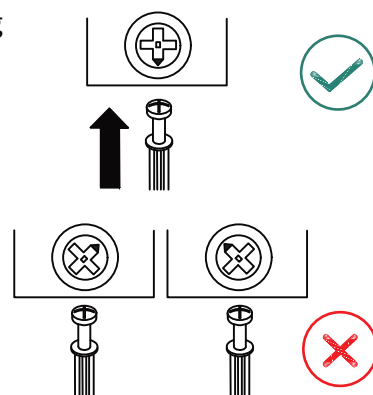

The QuickFit head should be in the center of the cam lock when the two panels are joined. The cam lock should be inserted before the QuickFit. Turn the cam lock clockwise to tighten.

Der Quickfit-Kopf sollte sich in der Mitte des Nockenschloss befinden, wenn die beiden Platten verbunden sind. Der Nockenschloss sollte vor dem Quickfit eingesetzt werden. Drehen Sie den Nockenschloss im Uhrzeigersinn, um ihn zu befestigen.

La tête du quickfit doit être au centre du serrure à came lorsque les deux panneaux sont assemblés. Le serrure à came doit être inséré avant le quickfit. Tournez le serrure à came dans le sens des aiguilles d'une montre pour le serrer.

La testa del quickfit dovrebbe essere al centro del serratura a leva quando i due pannelli sono uniti. Il serratura a leva deve essere inserito prima del quickfit. Ruotare il serratura a leva in senso orario per stringere.

La cabeza del quickfit debe estar en el centro del cam lock cuando los dos paneles estén unidos. El cierre de leva debe insertarse antes del quickfit. Gire el cierre de leva en sentido horario para apretar.

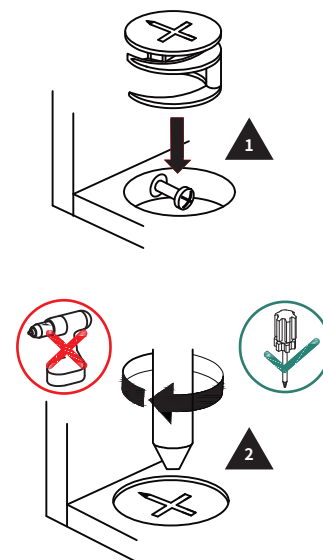



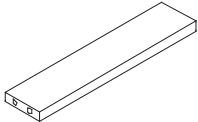
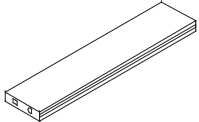
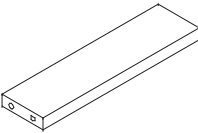
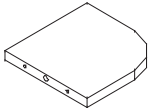
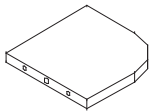
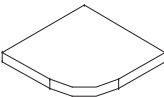
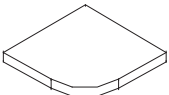
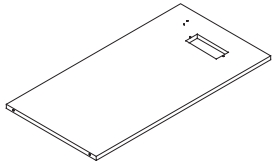
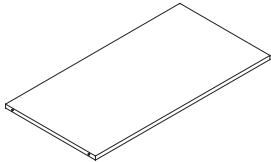
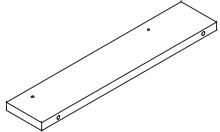
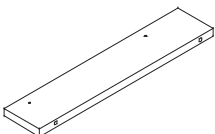
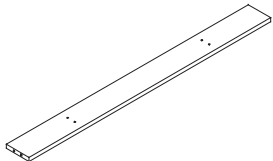
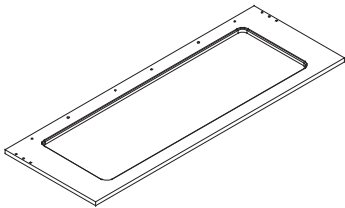
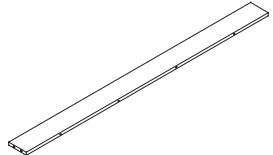

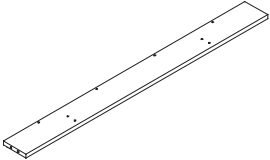
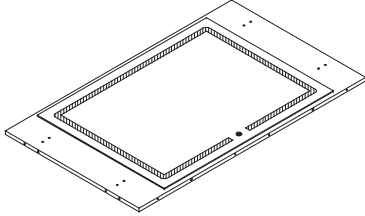
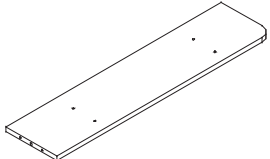
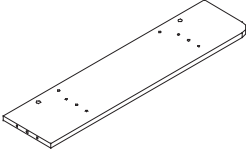
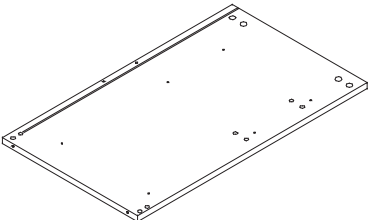
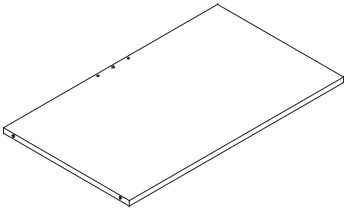
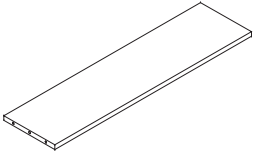
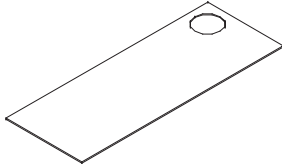
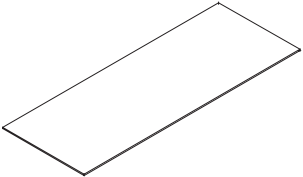
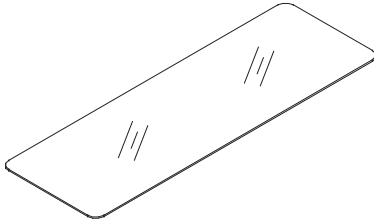
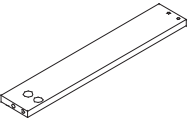
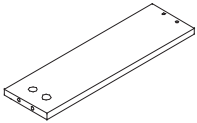
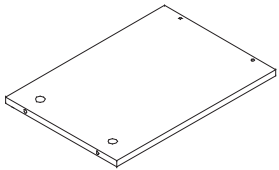
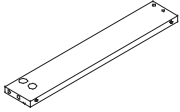
# PARTS

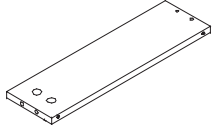
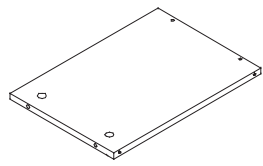
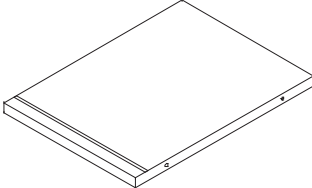
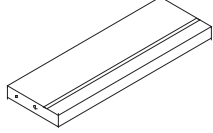
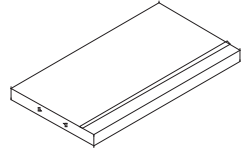
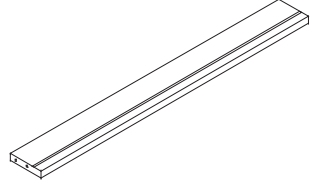
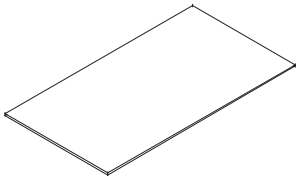
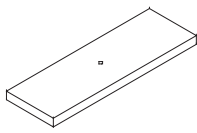
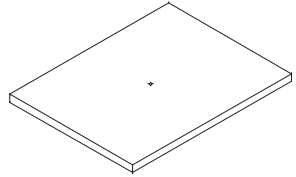
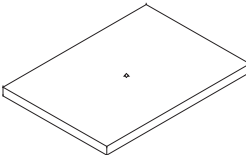
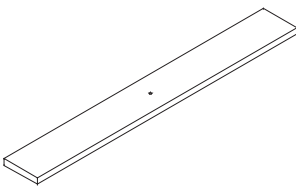
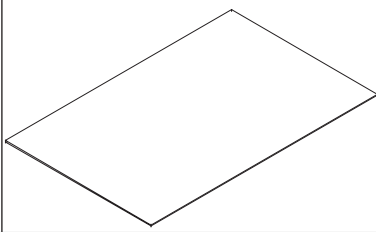
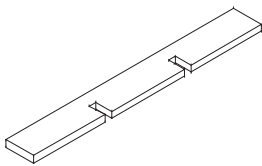
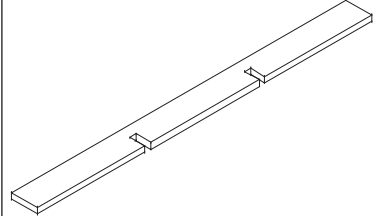

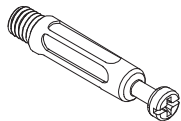
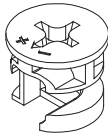
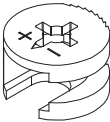
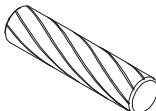
Item no. Nr. N° d'article Articolo No. Artículo No.	Reference Image Referenzbild Image de référence Immagine di riferimento Imagen de referencia	Qty. Menge Qté. Qtà Cant.	Item no. Nr. N° d'article Articolo No. Artículo No.	Reference Image Referenzbild Image de référence Immagine di riferimento Imagen de referencia	Qty. Menge Qté. Qtà Cant.
1		X2	2		X2
3		X4	4		X1
5		X1	6		X1
7		X1	8		X1
9		X1	10		X1
11		X1	12		X1
13		X1	14		X1

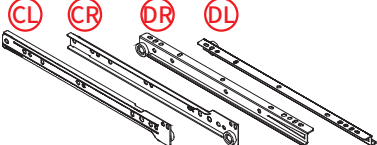
Item no. Nr. N° d'article Articolo No. Artículo No.	Reference Image Referenzbild Image de référence Immagine di riferimento Imagen de referencia	Qty. Menge Qté. Qtà Cant.	Item no. Nr. N° d'article Articolo No. Artículo No.	Reference Image Referenzbild Image de référence Immagine di riferimento Imagen de referencia	Qty. Menge Qté. Qtà Cant.
15		X1	16		X1
17		X1	18		X1
19		X1	20		X1
21		X1	22		X1
23		X1	24		X1
25		X3	26		X4
27		X2	28		X3

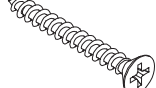
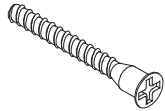
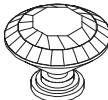
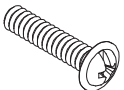
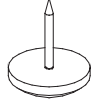
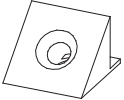
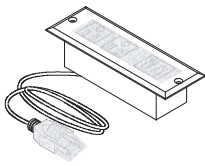
Item no. Nr. N° d'article Articolo No. Artículo No.	Reference Image Referenzbild Image de référence Immagine di riferimento Imagen de referencia	Qty. Menge Qté. Qtà Cant.	Item no. Nr. N° d'article Articolo No. Artículo No.	Reference Image Referenzbild Image de référence Immagine di riferimento Imagen de referencia	Qty. Menge Qté. Qtà Cant.
29		X4	30		X2
31		X2	32		X2
33		X4	34		X1
35		X8	36		X2
37		X2	38		X4
39		X1	40		X1
41		X2	42		X2

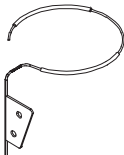
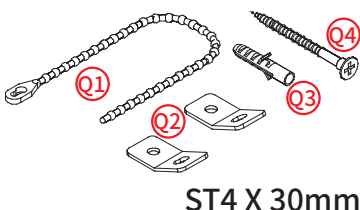
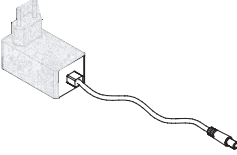
Item no. Nr. N° d'article Articolo No. Artículo No.	Reference Image Referenzbild Image de référence Immagine di riferimento Imagen de referencia	Qty. Menge Qté. Qtà Cant.	Item no. Nr. N° d'article Articolo No. Artículo No.	Reference Image Referenzbild Image de référence Immagine di riferimento Imagen de referencia	Qty. Menge Qté. Qtà Cant.
<b>A</b>		X103 + 2extra	<b>B</b>	 φ15 X 12mm	X44 + 2extra
<b>C</b>	 φ15 X 9mm	X59 + 2extra	<b>D</b>	 φ8 X 40mm	X6 + 1extra
<b>E</b>	 φ6 X 30mm	X12 + 1extra	<b>F</b>	 L350mm	X9
<b>G</b>	 ST3.5 X 14mm	X86 + 4extra	<b>H</b>	 ST3.5 X 35mm	X40 + 2extra
<b>I</b>	 M5 X 40mm	X36 + 1extra	<b>J</b>		X9 + 1extra
<b>K</b>	 M4 X 15mm	X9 + 1extra	<b>L</b>		X8
<b>M</b>		X8	<b>N</b>		X1

Item no. Nr. N° d'article Articolo No. Artículo No.	Reference Image Referenzbild Image de référence Immagine di riferimento Imagen de referencia	Qty. Menge Qté. Qtà Cant.
O		X1
Q	 ST4 X 30mm	X2
S		X1

Item no. Nr. N° d'article Articolo No. Artículo No.	Reference Image Referenzbild Image de référence Immagine di riferimento Imagen de referencia	Qty. Menge Qté. Qtà Cant.
P		X8
R		X10

# EXPLODED VIEW

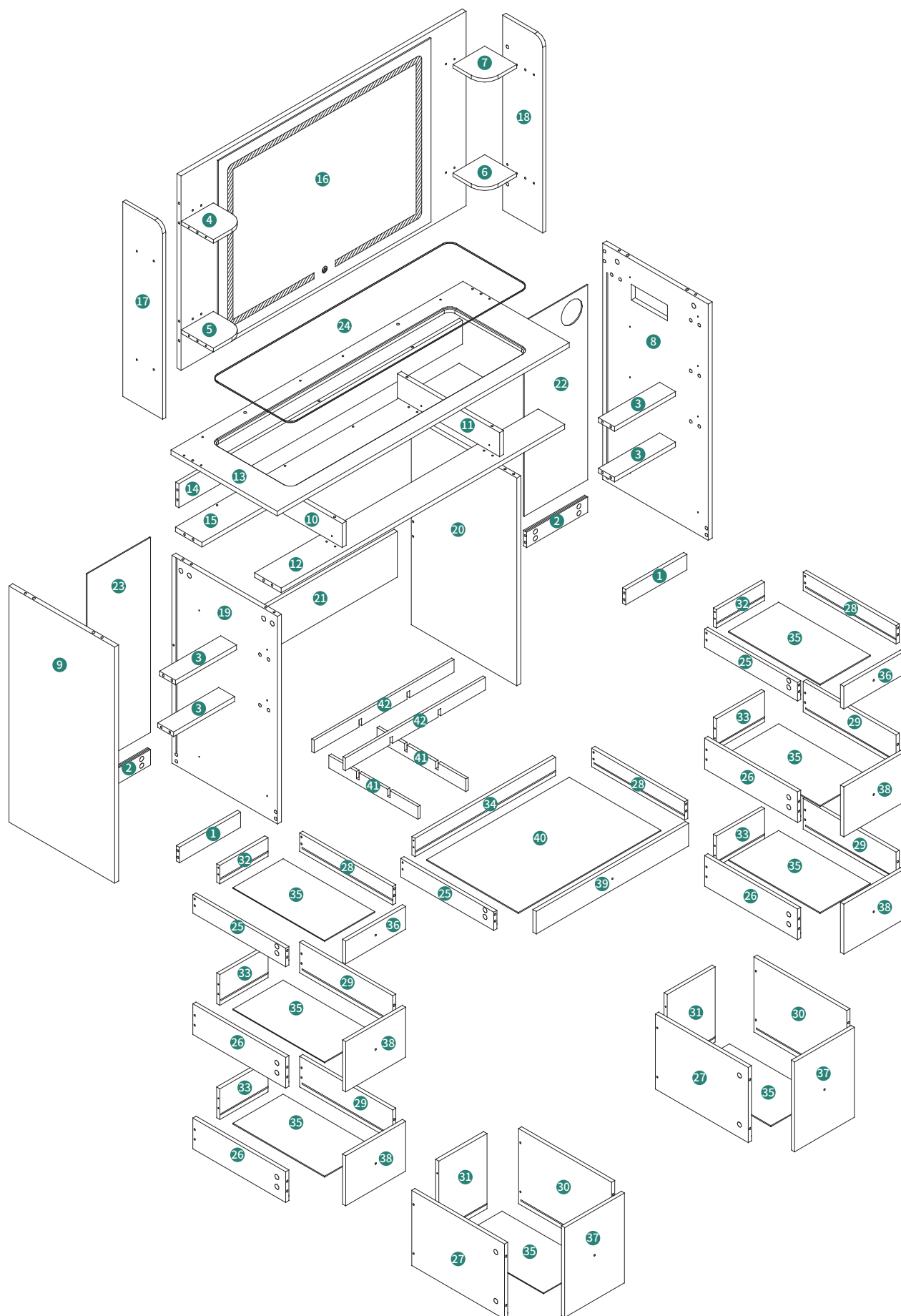

# ASSEMBLY

1

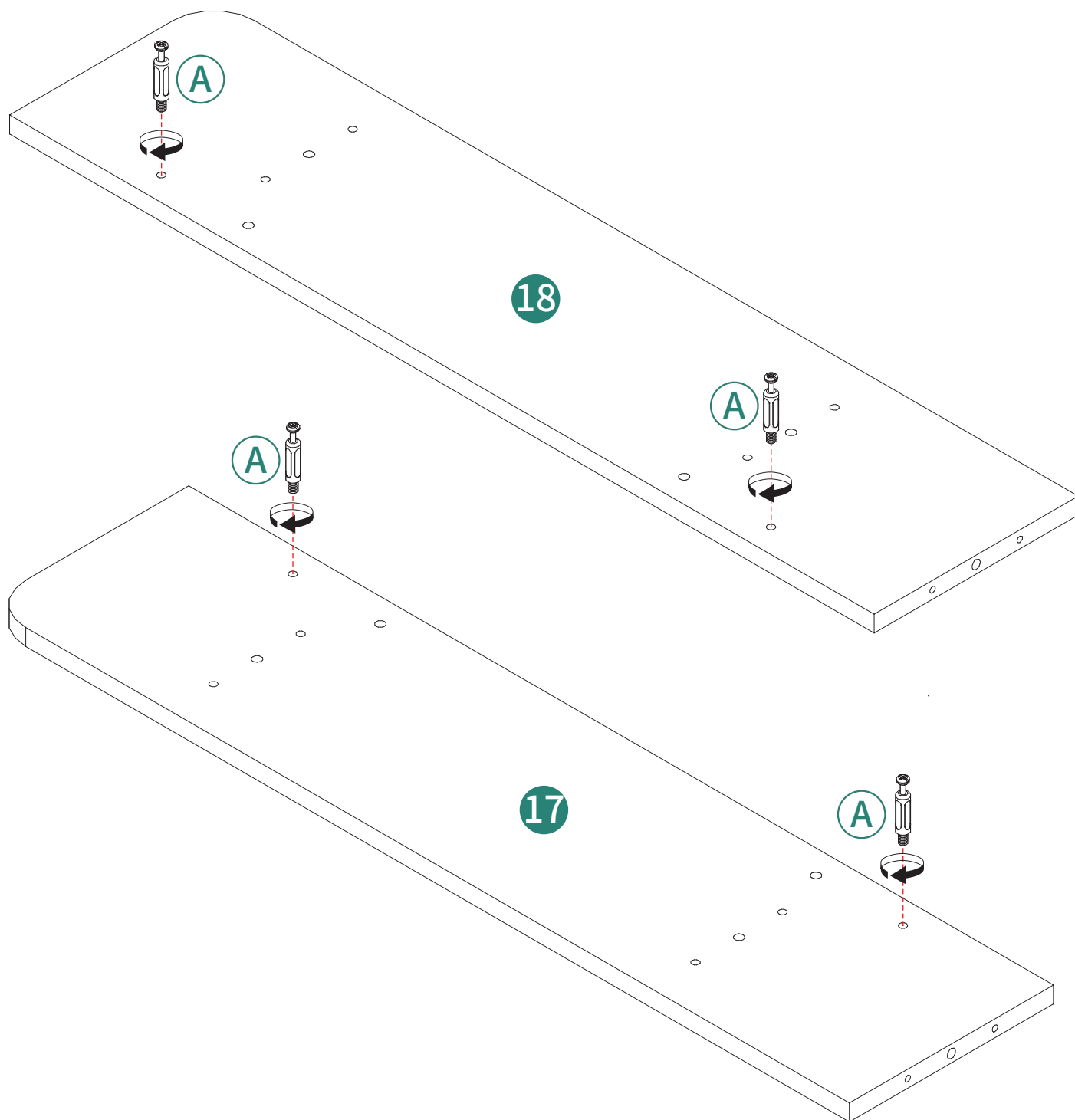
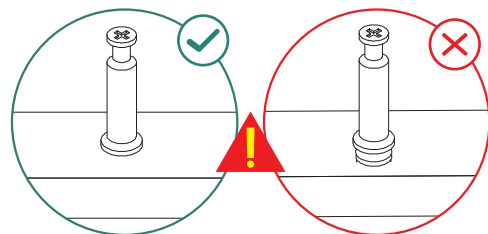
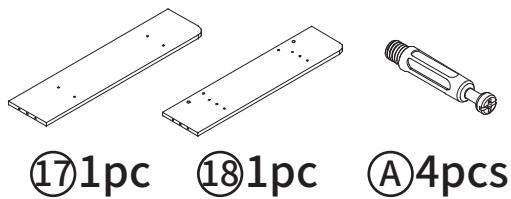





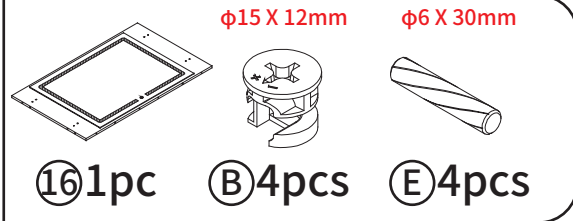



**2**

$\phi 15 \times 12\text{mm}$        $\phi 6 \times 30\text{mm}$



**16** 1pc      **B** 4pcs      **E** 4pcs

    <p><math>\phi 15 \times 12\text{mm}</math>      <math>\phi 15 \times 9\text{mm}</math></p> <p><b>B</b>                      <b>C</b></p>	    <p><math>\phi 8 \times 40\text{mm}</math>      <math>\phi 6 \times 30\text{mm}</math></p> <p><b>D</b>                      <b>E</b></p>
--	---

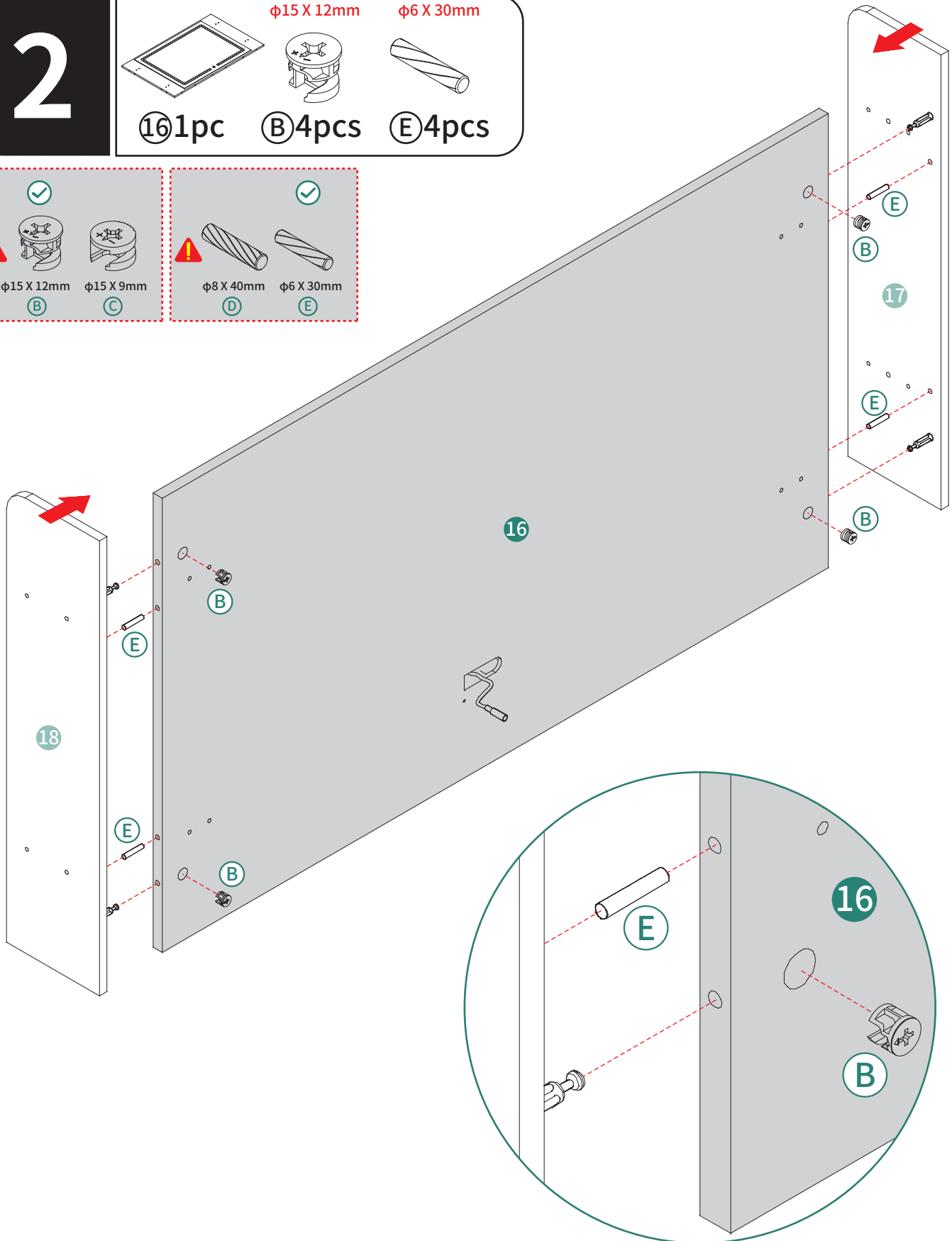

# 3

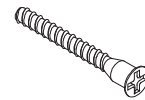
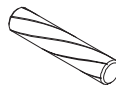
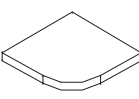
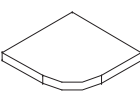
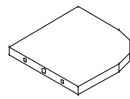
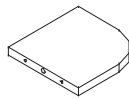

$\phi 6 \times 30\text{mm}$

M5 X 40mm

④ 1pc

⑤ 1pc

⑥ 1pc

⑦ 1pc

Ⓔ 4pcs

Ⓘ 16pcs

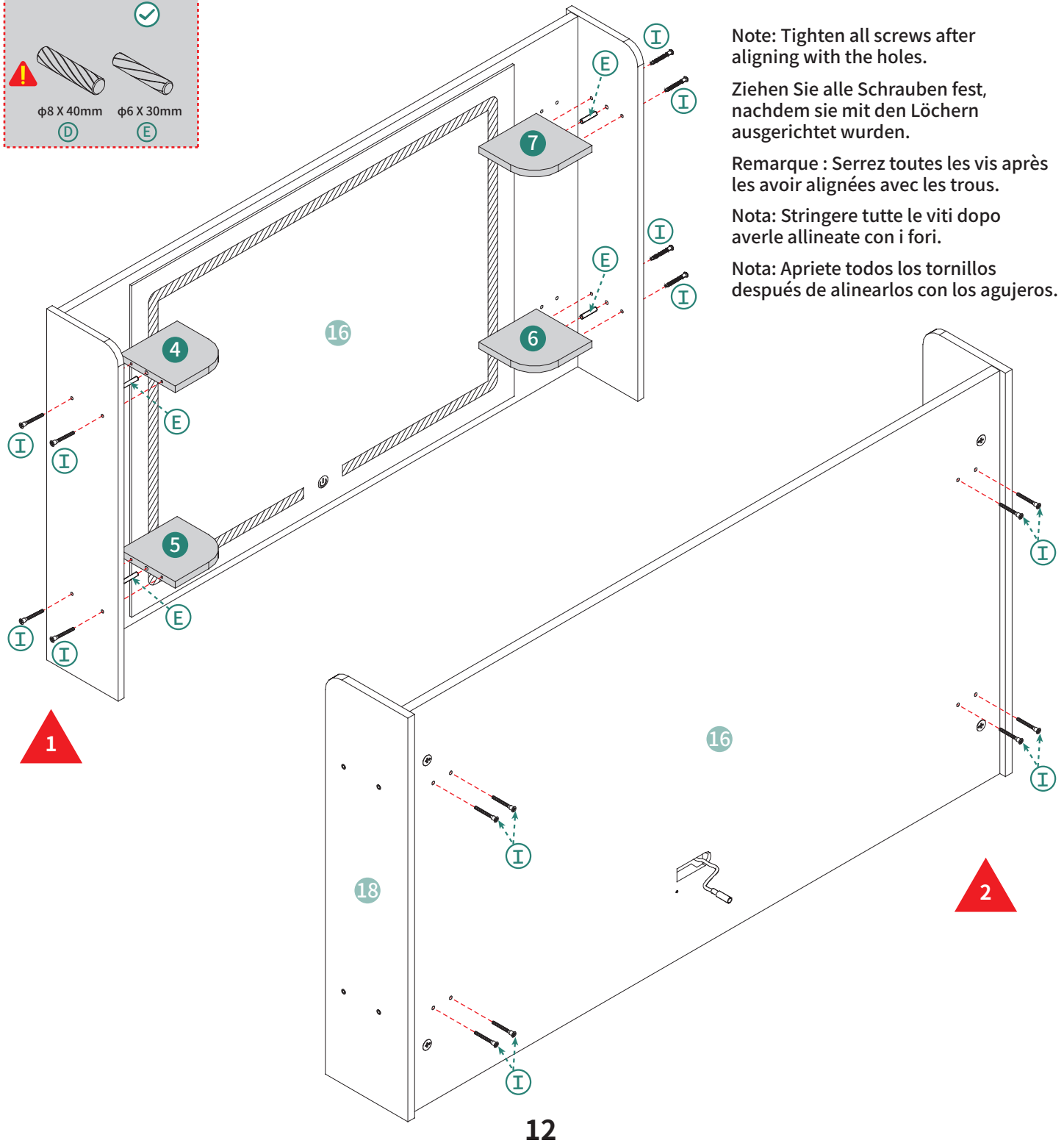
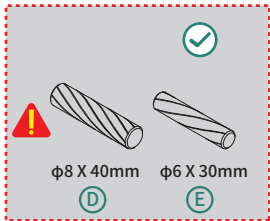

Note: Tighten all screws after aligning with the holes.

Ziehen Sie alle Schrauben fest, nachdem sie mit den Löchern ausgerichtet wurden.

Remarque : Serrez toutes les vis après les avoir alignées avec les trous.

Nota: Stringere tutte le viti dopo averle allineate con i fori.

Nota: Apriete todos los tornillos después de alinearlos con los agujeros.

# 4

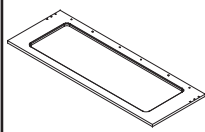

φ8 X 40mm

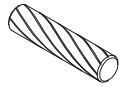

φ6 X 30mm

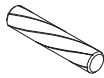

M5 X 40mm

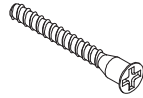

⑬1pc    ④2pcs    ⑤2pcs    ①8pcs

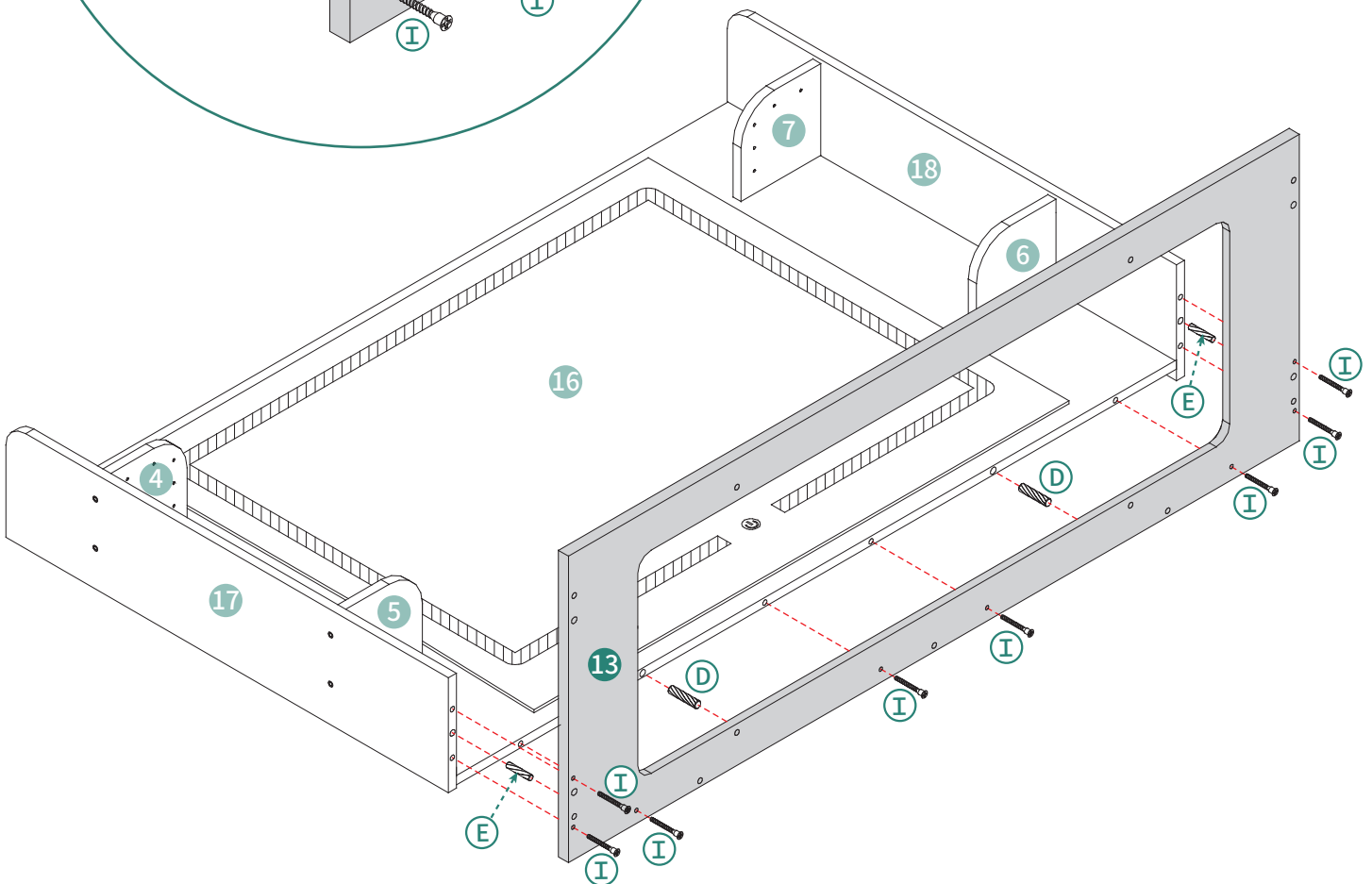
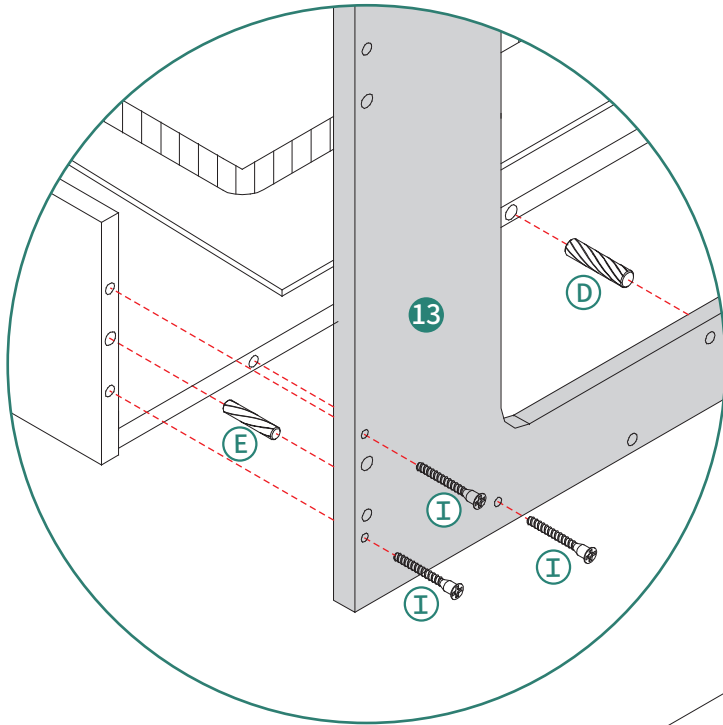
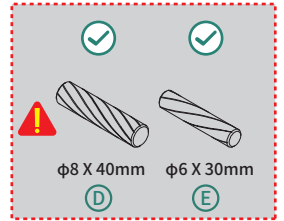

**5**

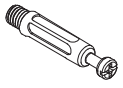

Ⓐ 11pcs

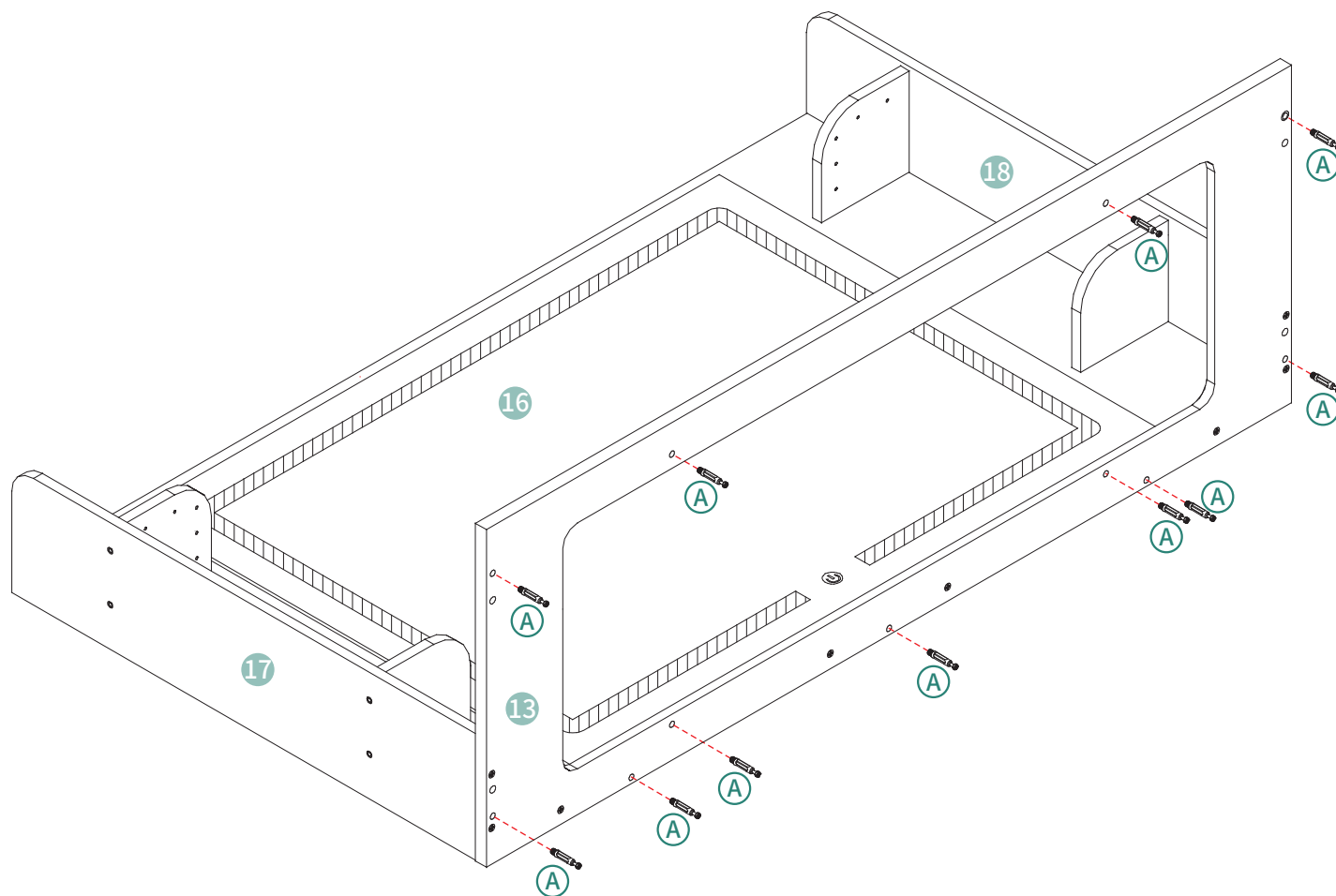
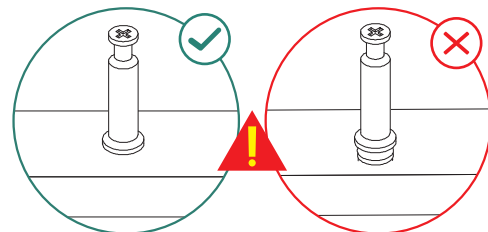

**6**



Ⓜ 10pcs

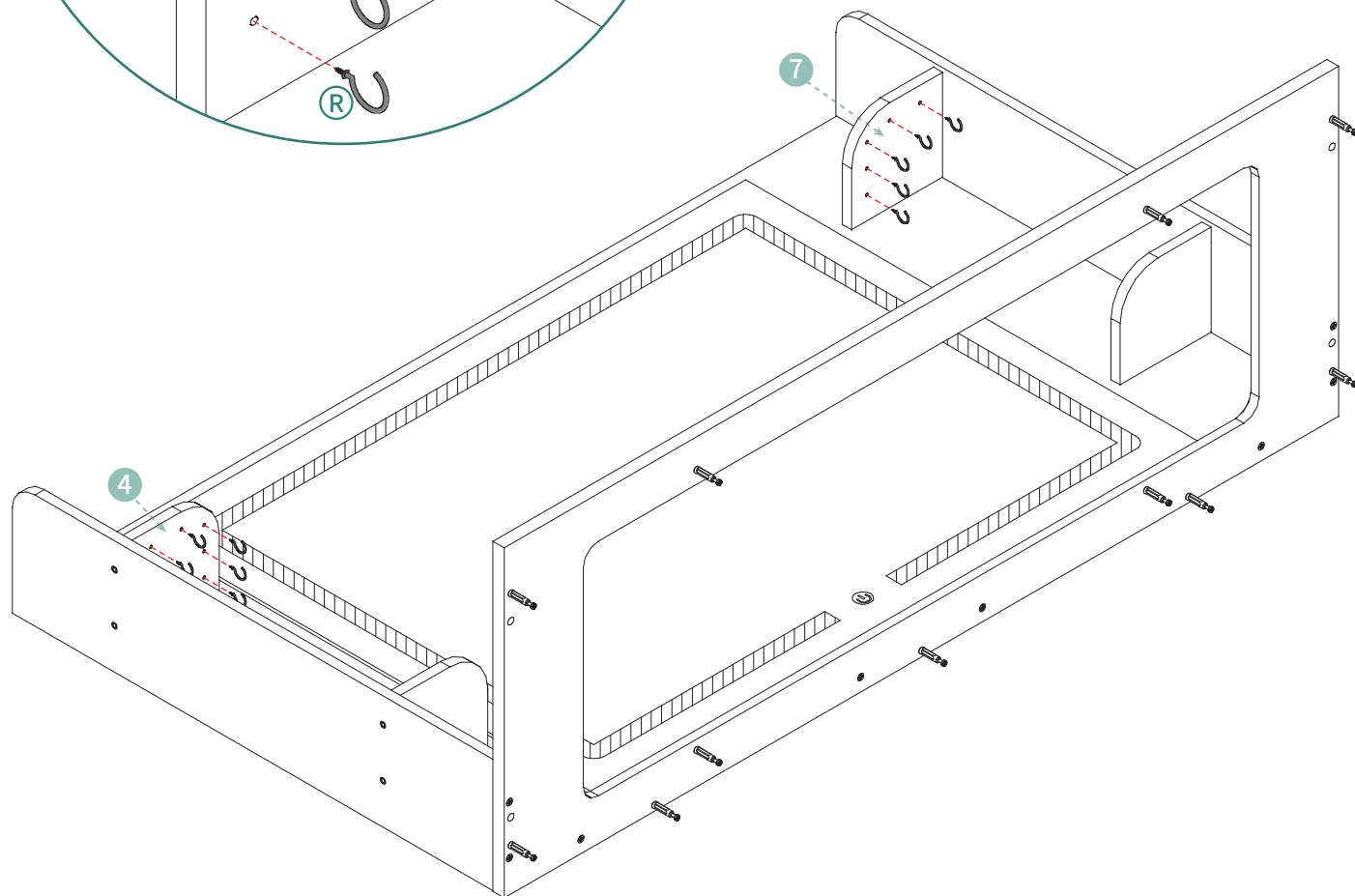
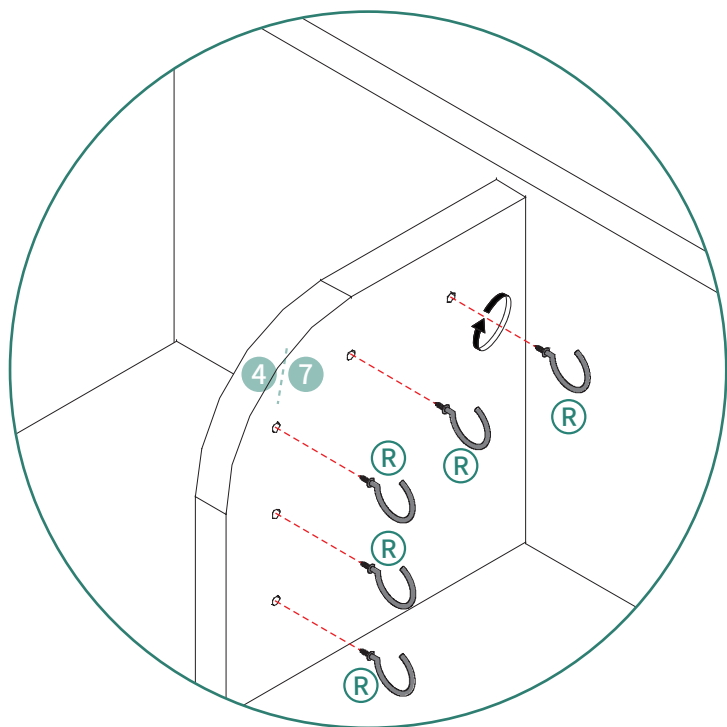

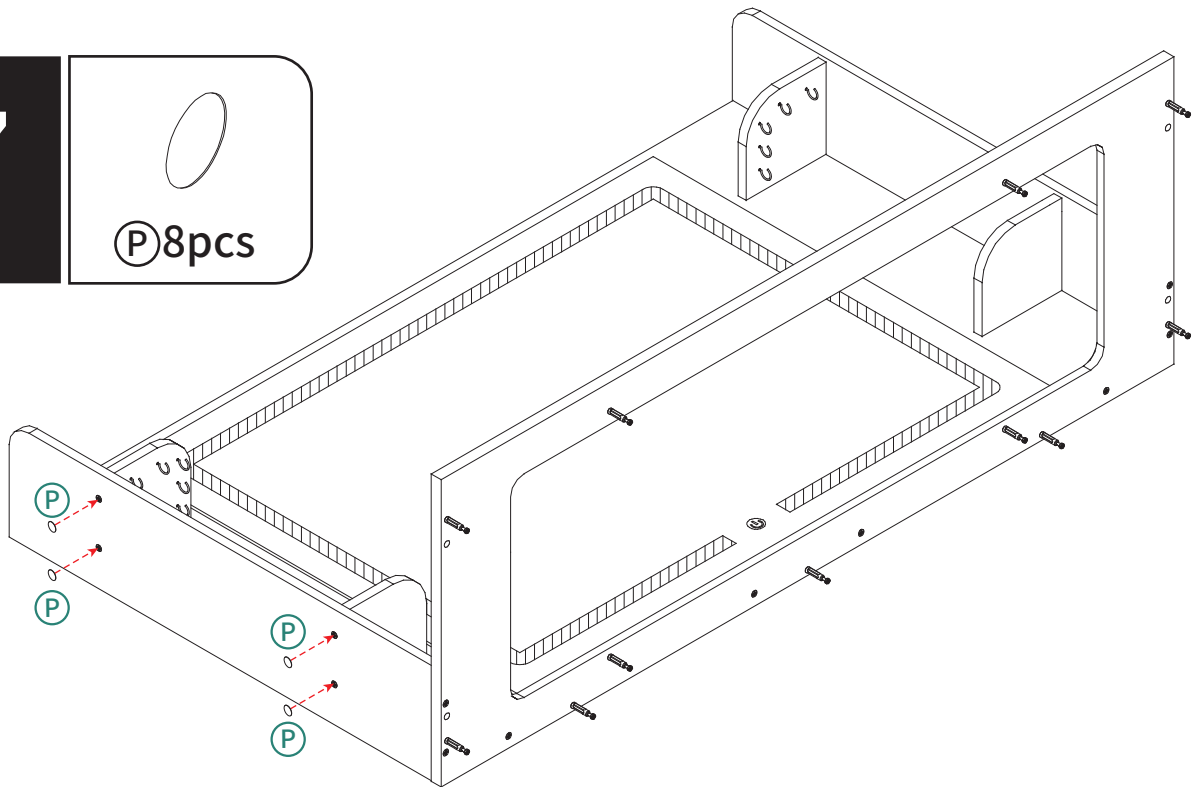

In order to make the product more beautiful, please paste hardware P on the exposed holes

Um das Produkt schöner zu gestalten, bitte Hardware P auf das freiliegende Loch kleben.

Pour rendre le produit plus beau, veuillez coller la pièce P sur le trou exposé.

Per rendere il prodotto più bello, si prega di incollare l'hardware P sul foro esposto.

Para hacer que el producto sea más hermoso, por favor pegue el hardware P en el agujero expuesto.

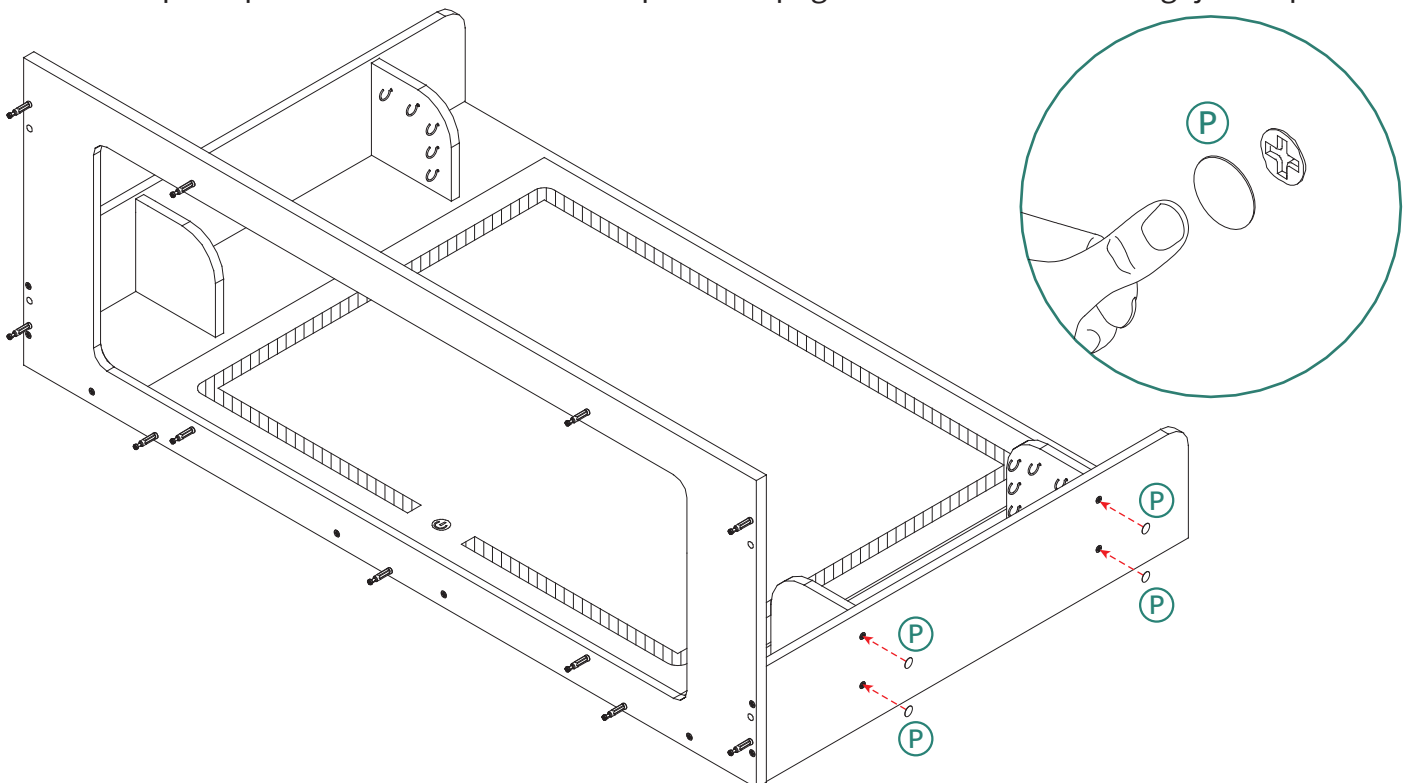

8

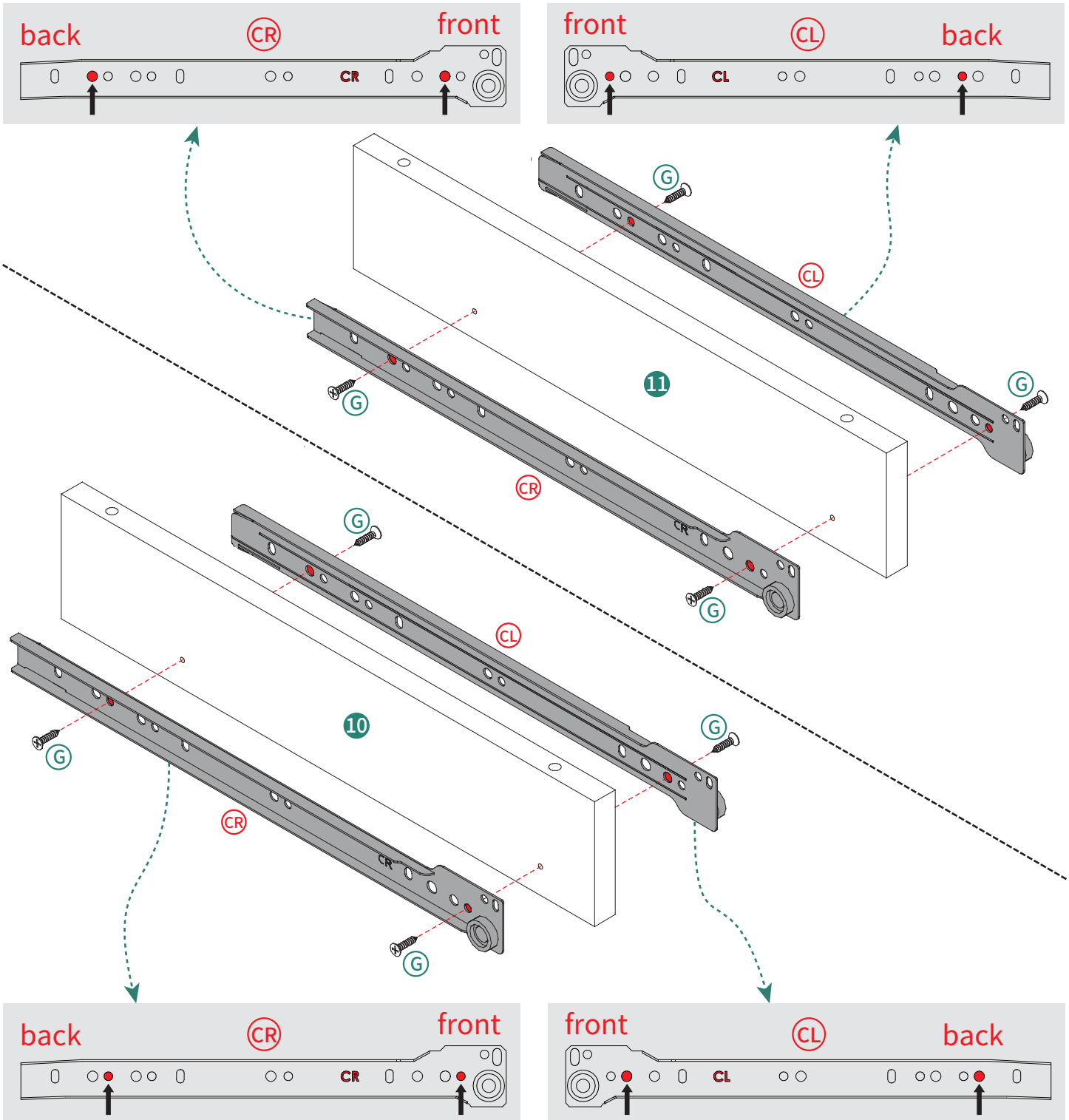
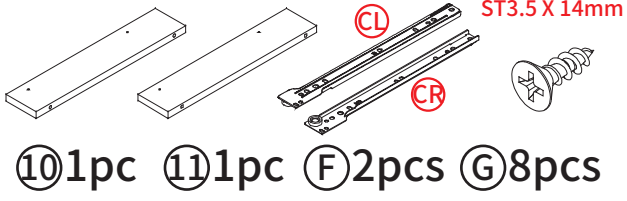

**9**

M5 X 40mm

⑫1pc   ⑮1pc   ①8pcs

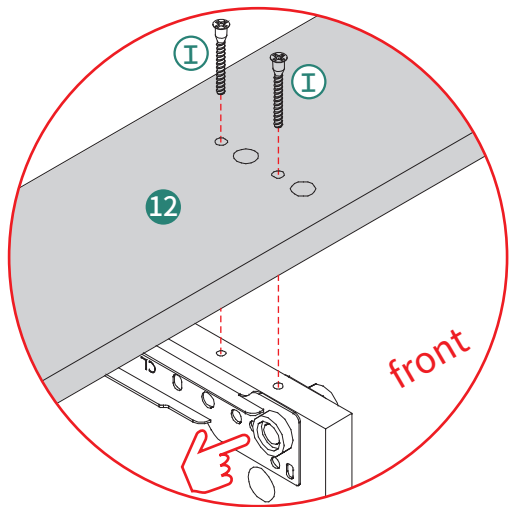
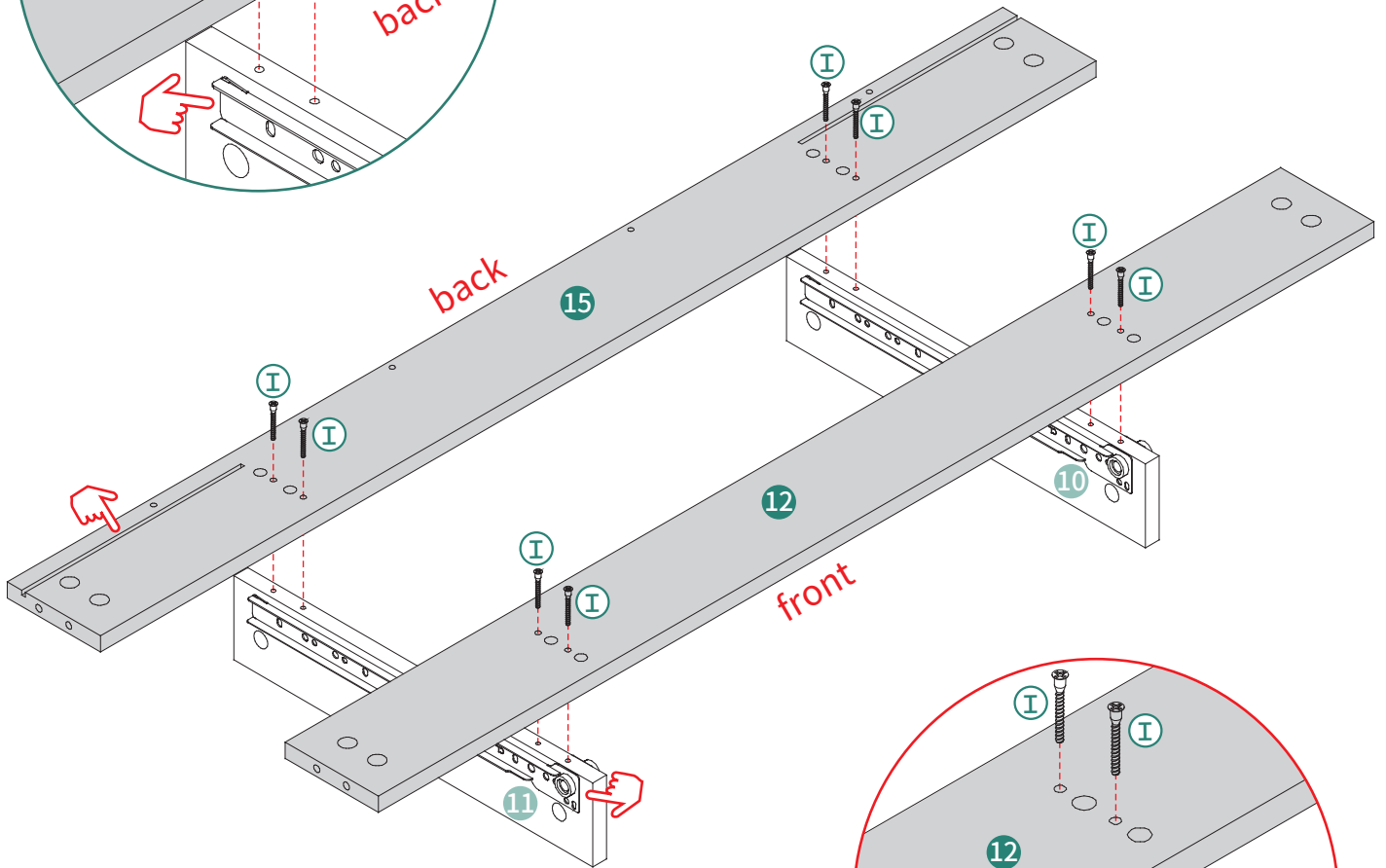
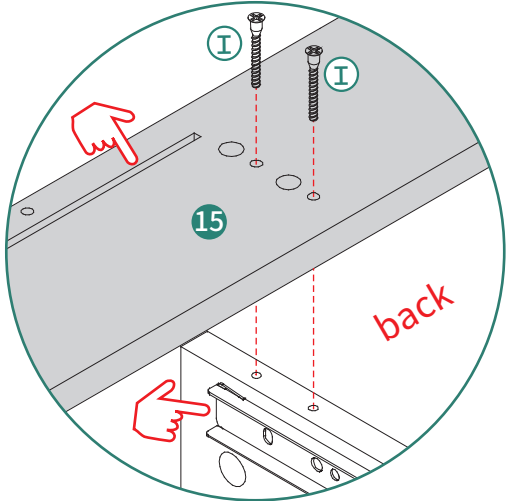

# 10

ST3.5 X 35mm

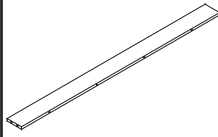

⑭ 1pc



Ⓐ 8pcs

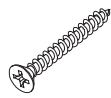

Ⓗ 4pcs

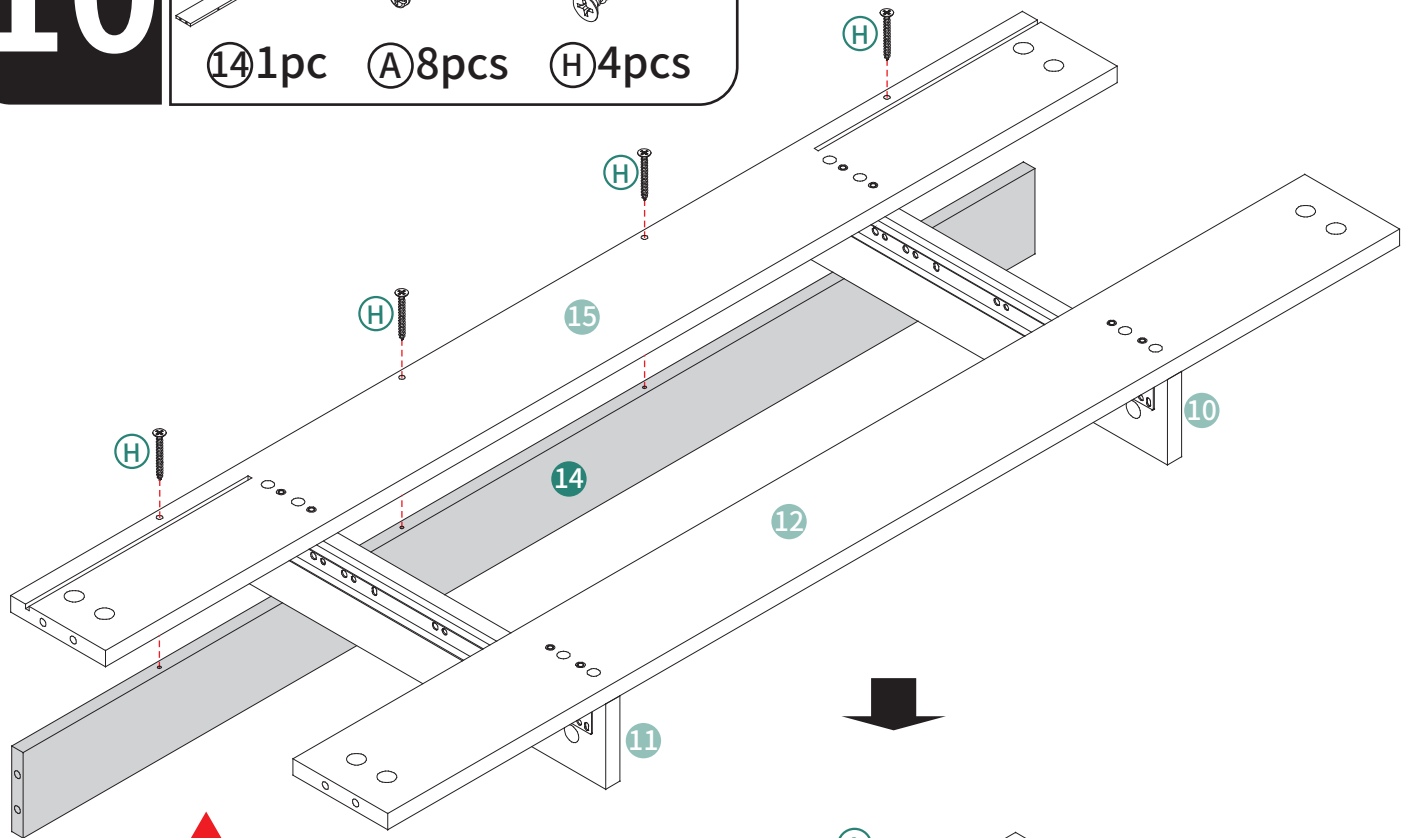

1

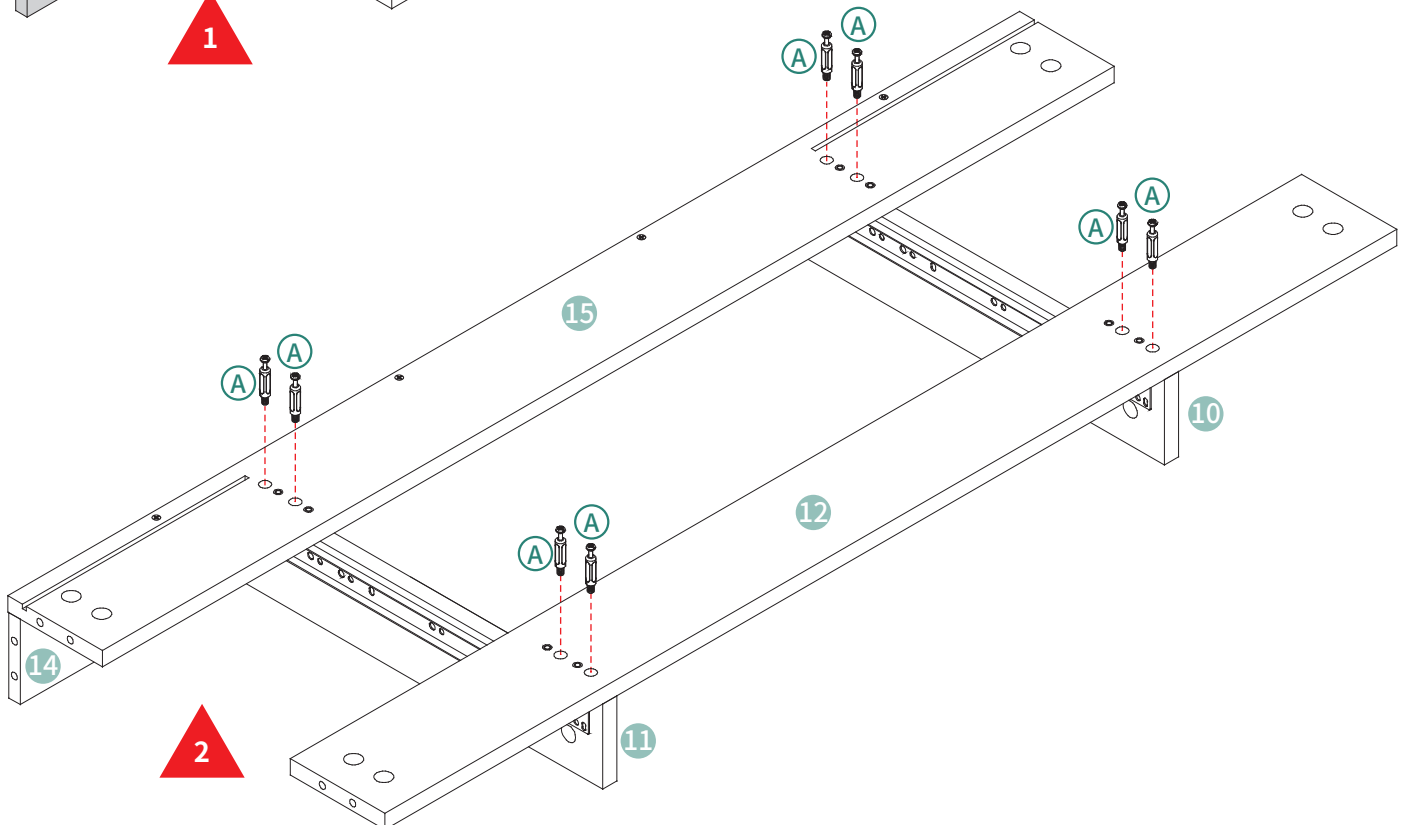

2

# 11

⑨ 1pc ⑳ 1pc ㉑ 7pcs ㉒ 14pcs

CL ST3.5 X 14mm

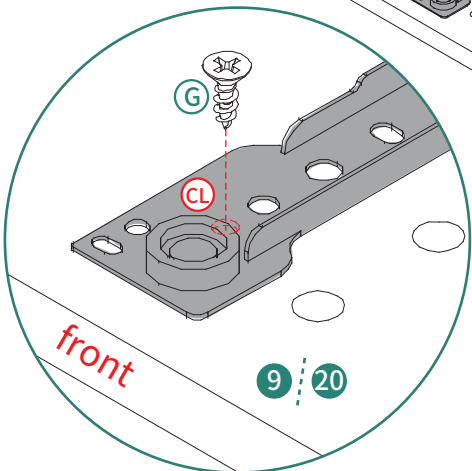
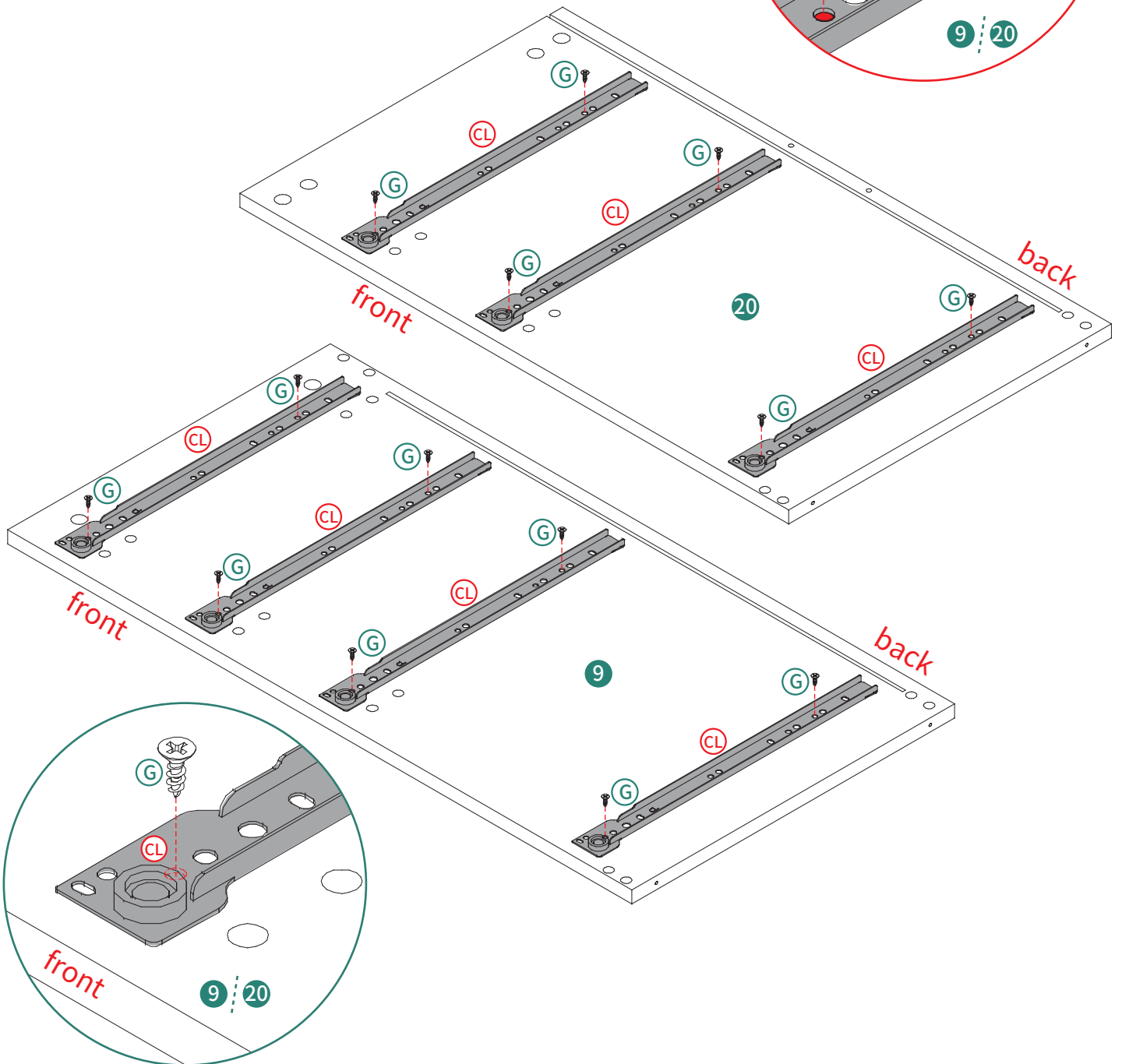
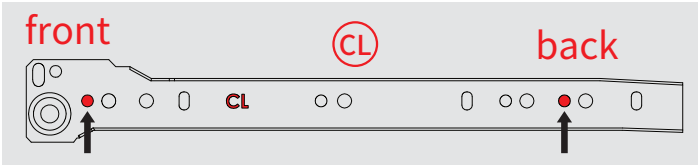
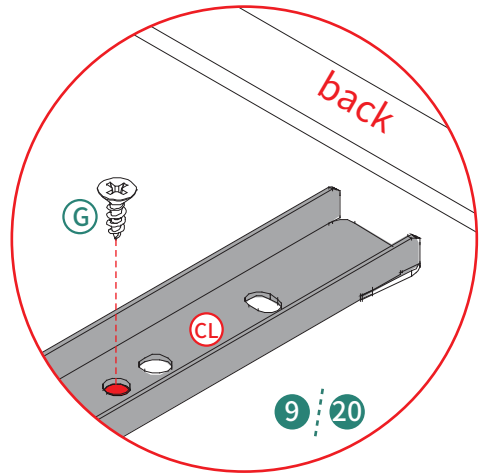

# 12

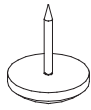
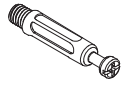

Ⓐ 22pcs Ⓛ 4pcs

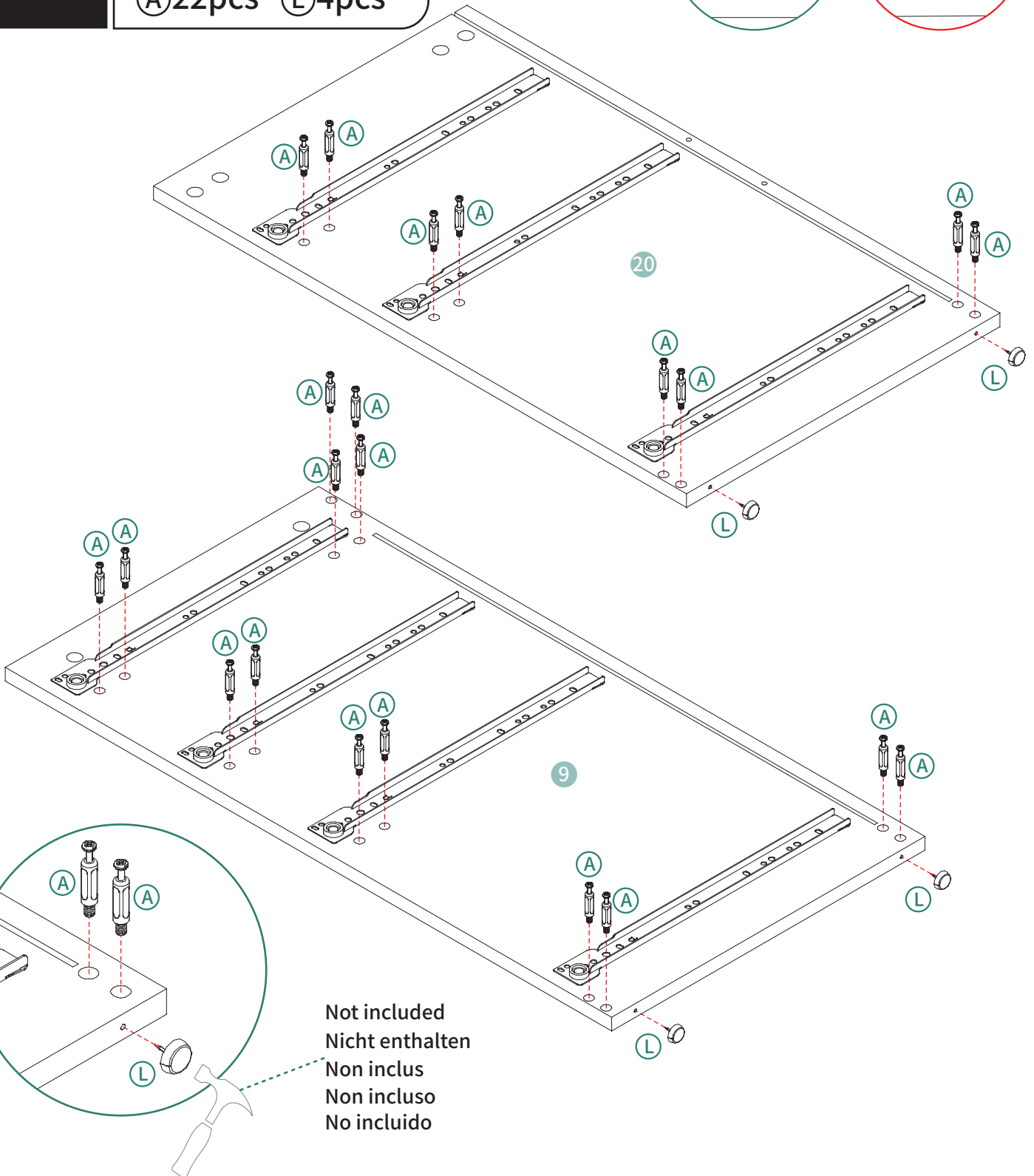
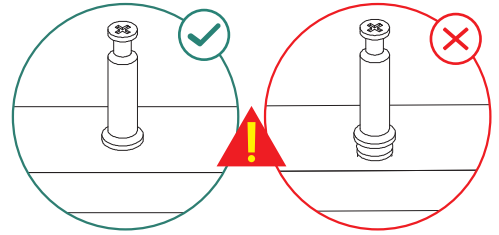

Not included  
Nicht enthalten  
Non inclus  
Non incluso  
No incluido

# 13

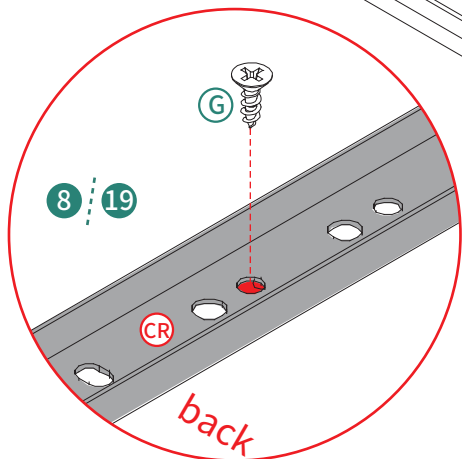
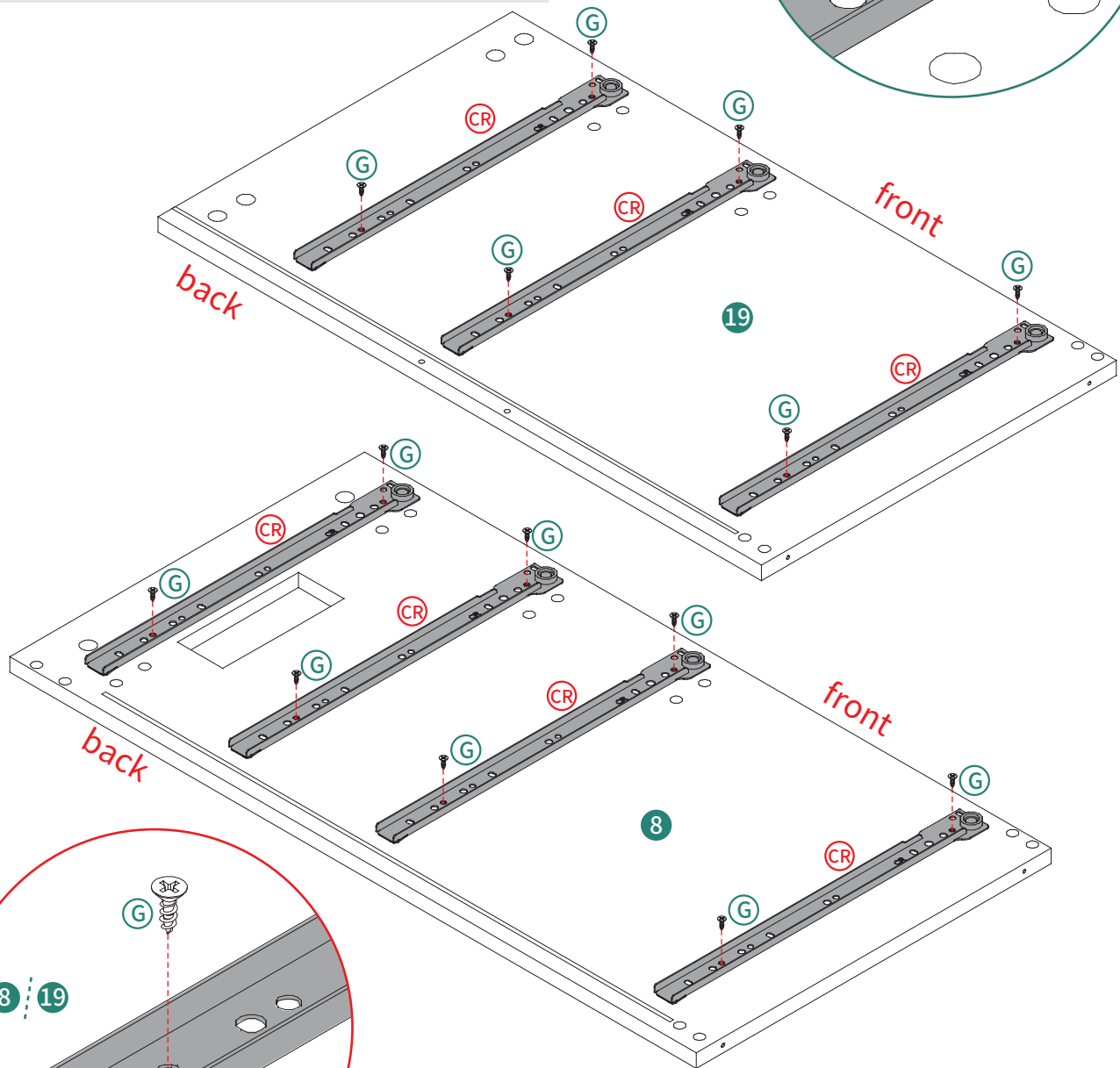
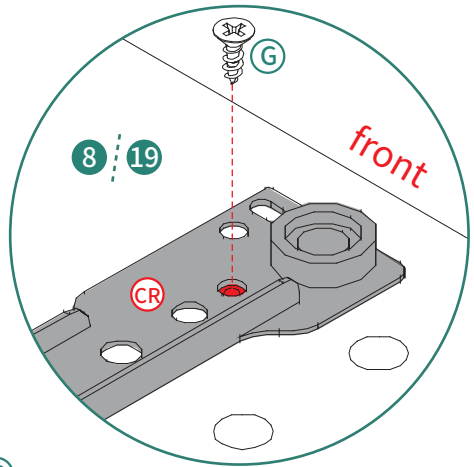
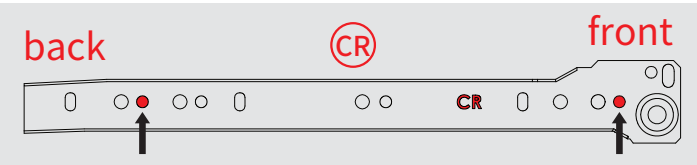
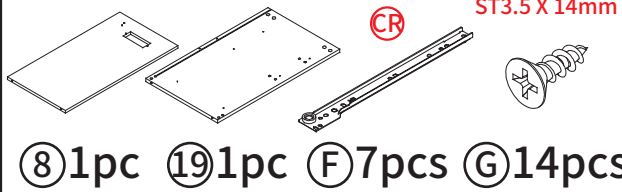

# 14

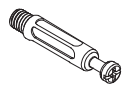

Ⓐ 22pcs Ⓛ 4pcs

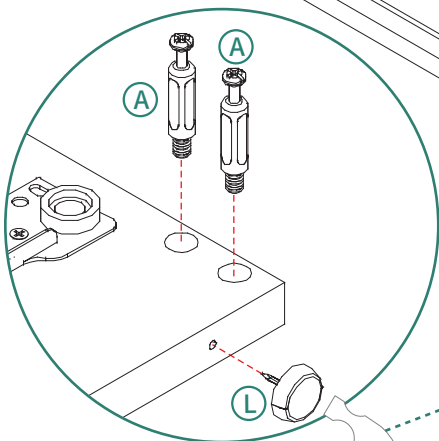
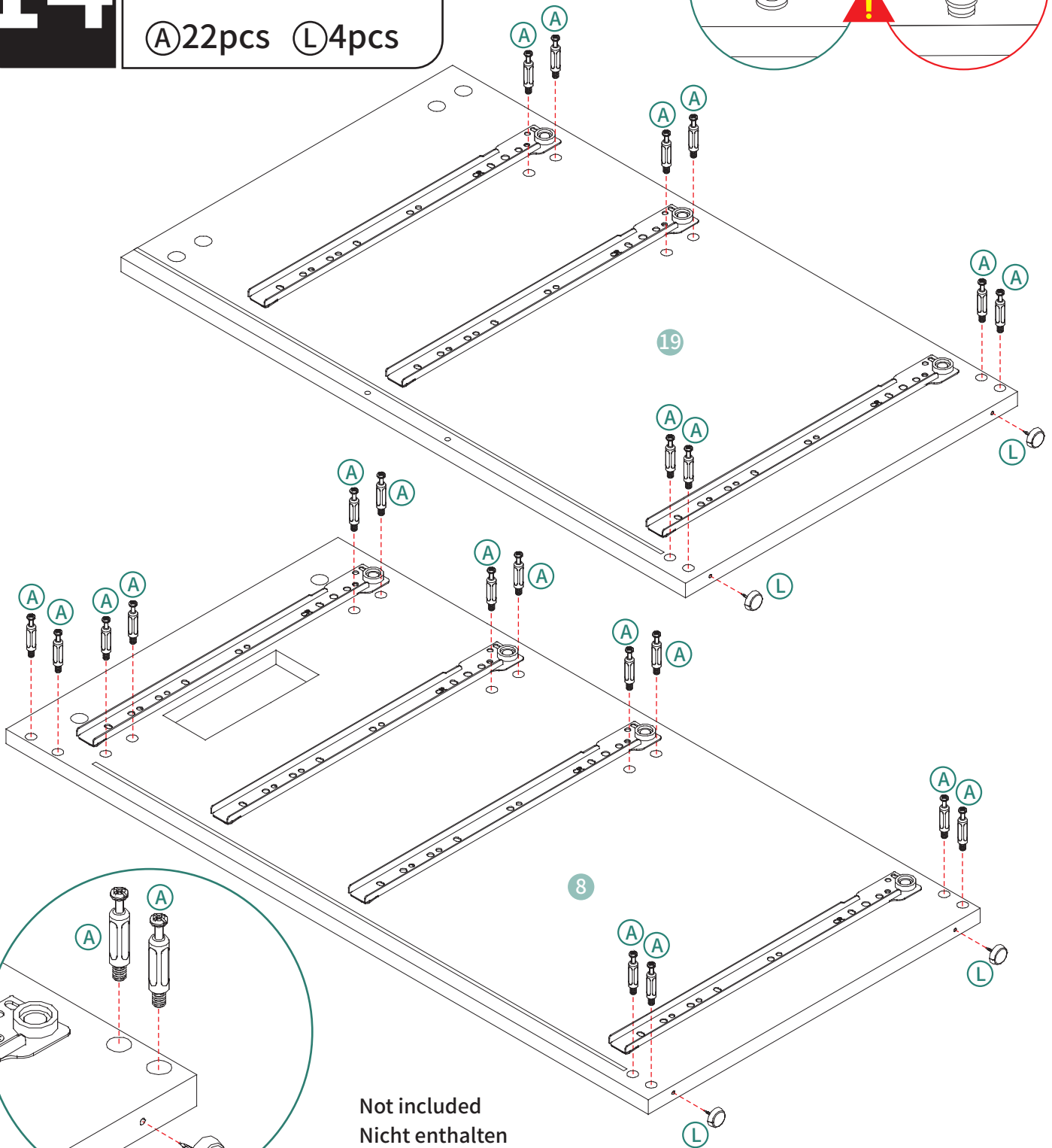
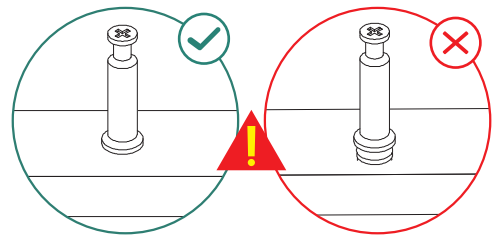

Not included  
Nicht enthalten  
Non inclus  
Non incluso  
No incluido

# 15

$\phi 6 \times 30\text{mm}$        $M5 \times 40\text{mm}$

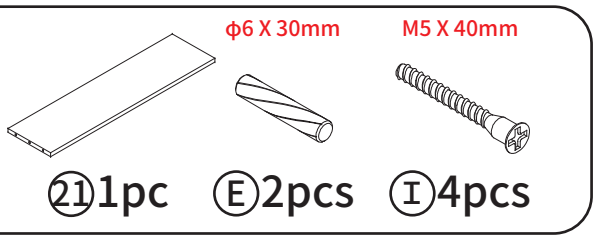

②1 1pc    ③E 2pcs    ④I 4pcs

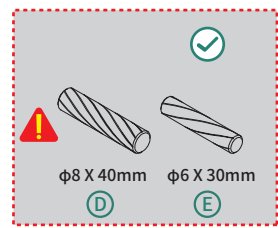

$\phi 8 \times 40\text{mm}$      $\phi 6 \times 30\text{mm}$

③D      ③E

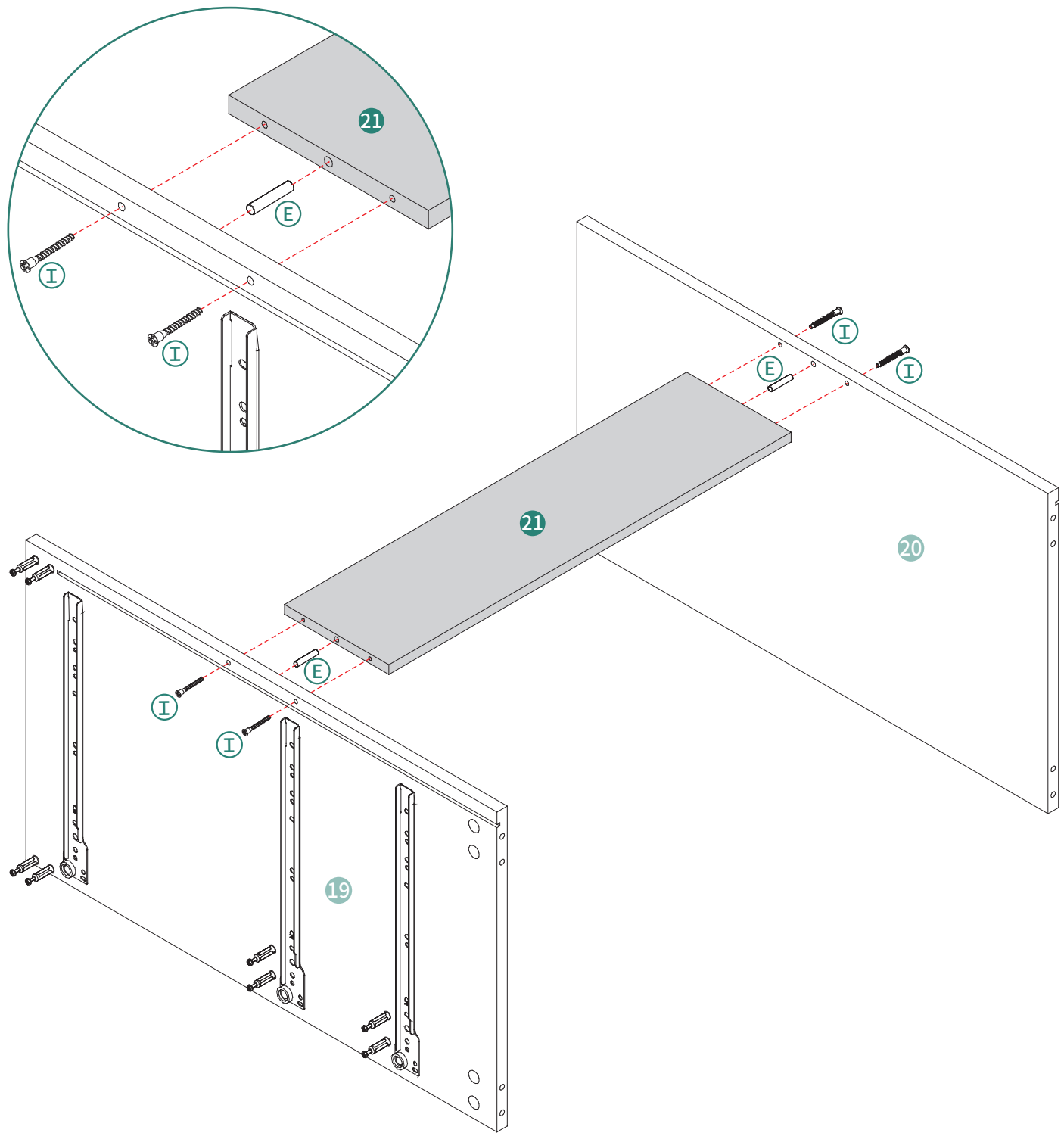

# 16

φ15 X 12mm

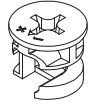

Ⓑ 8pcs

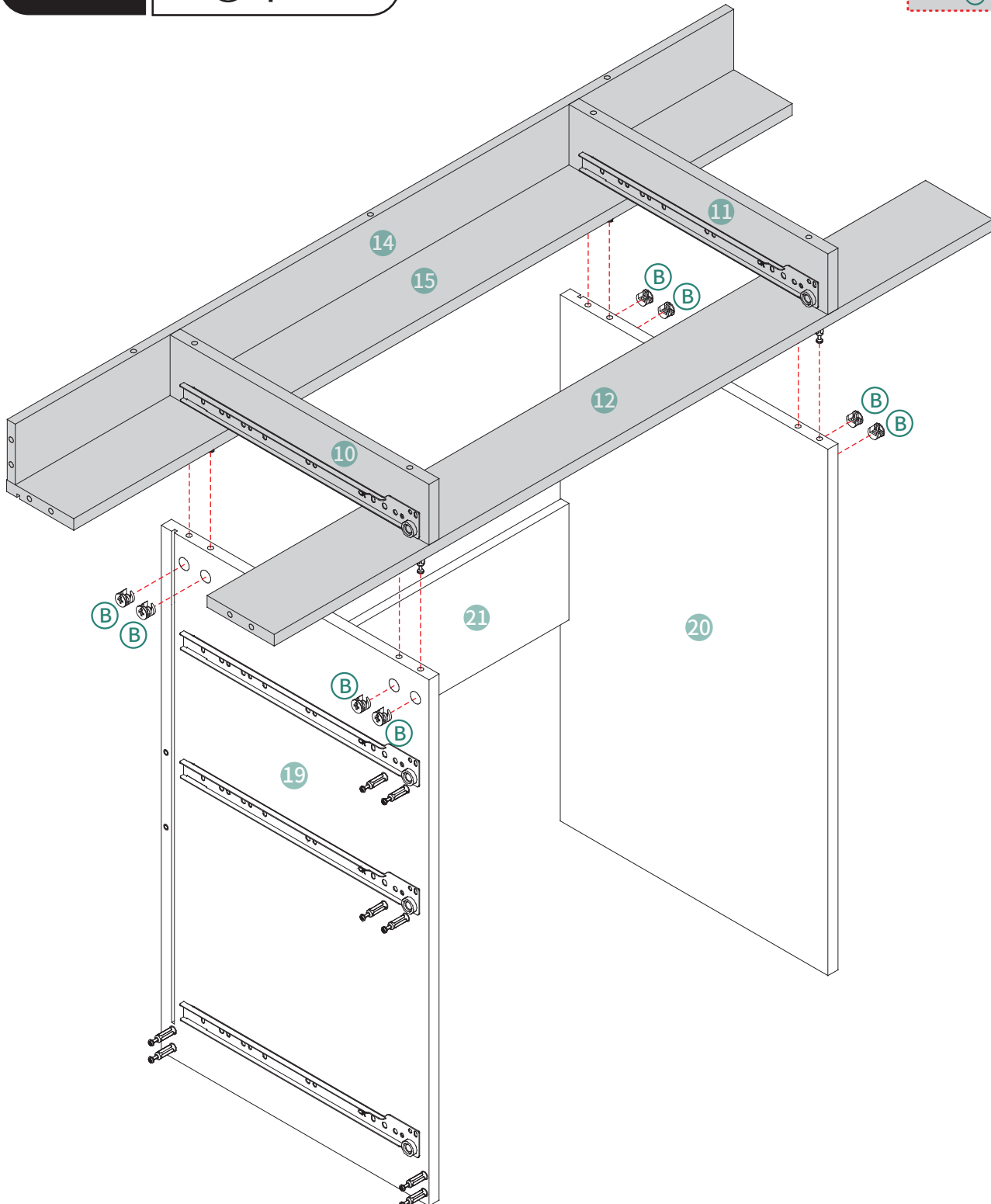
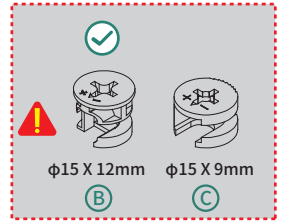

# 17

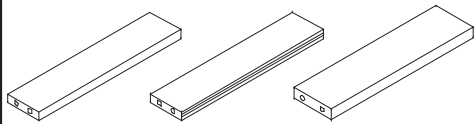

φ15 X 12mm

φ15 X 9mm



①1pc ②1pc ③2pcs ④4pcs ⑤4pcs

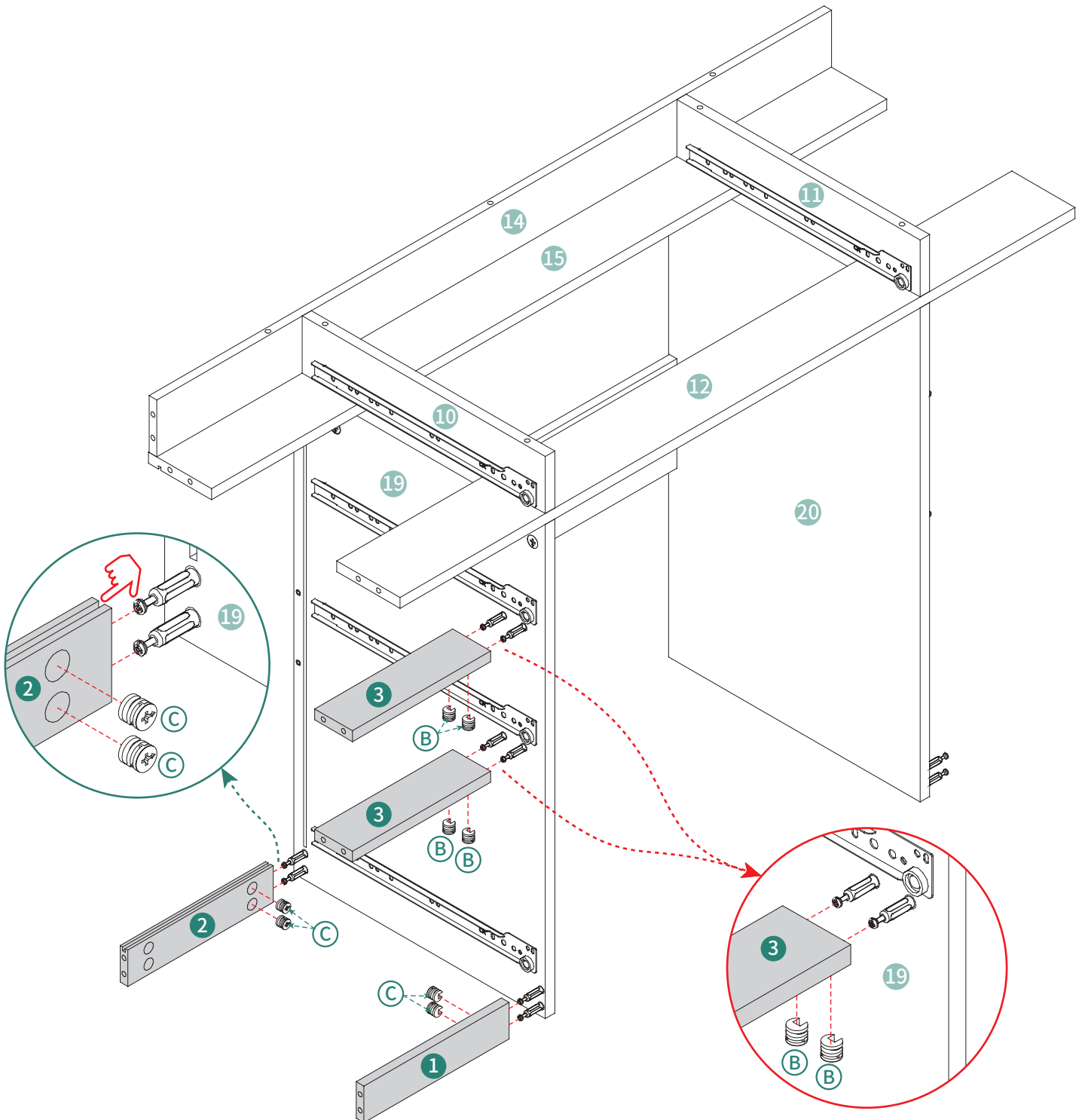
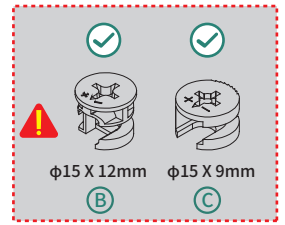

# 18

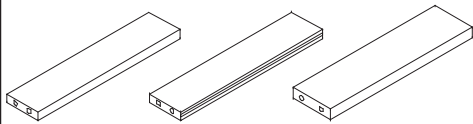

φ15 X 12mm

φ15 X 9mm



①1pc ②1pc ③2pcs ④4pcs ⑤4pcs

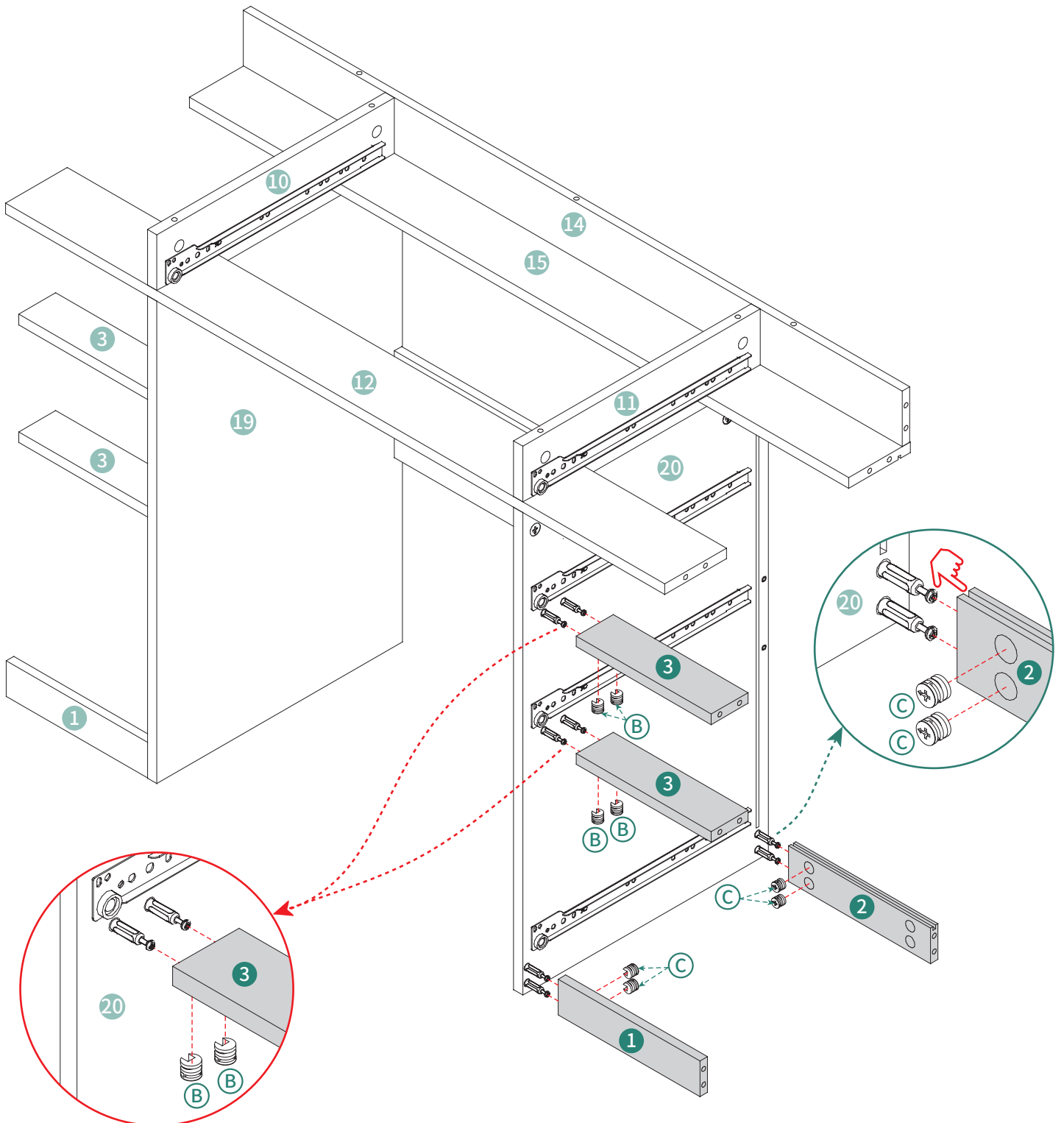
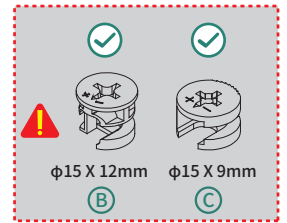

**19**

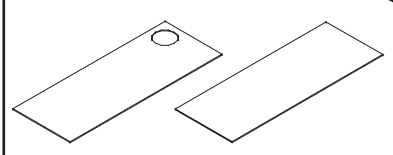

②②1pc ②③1pc

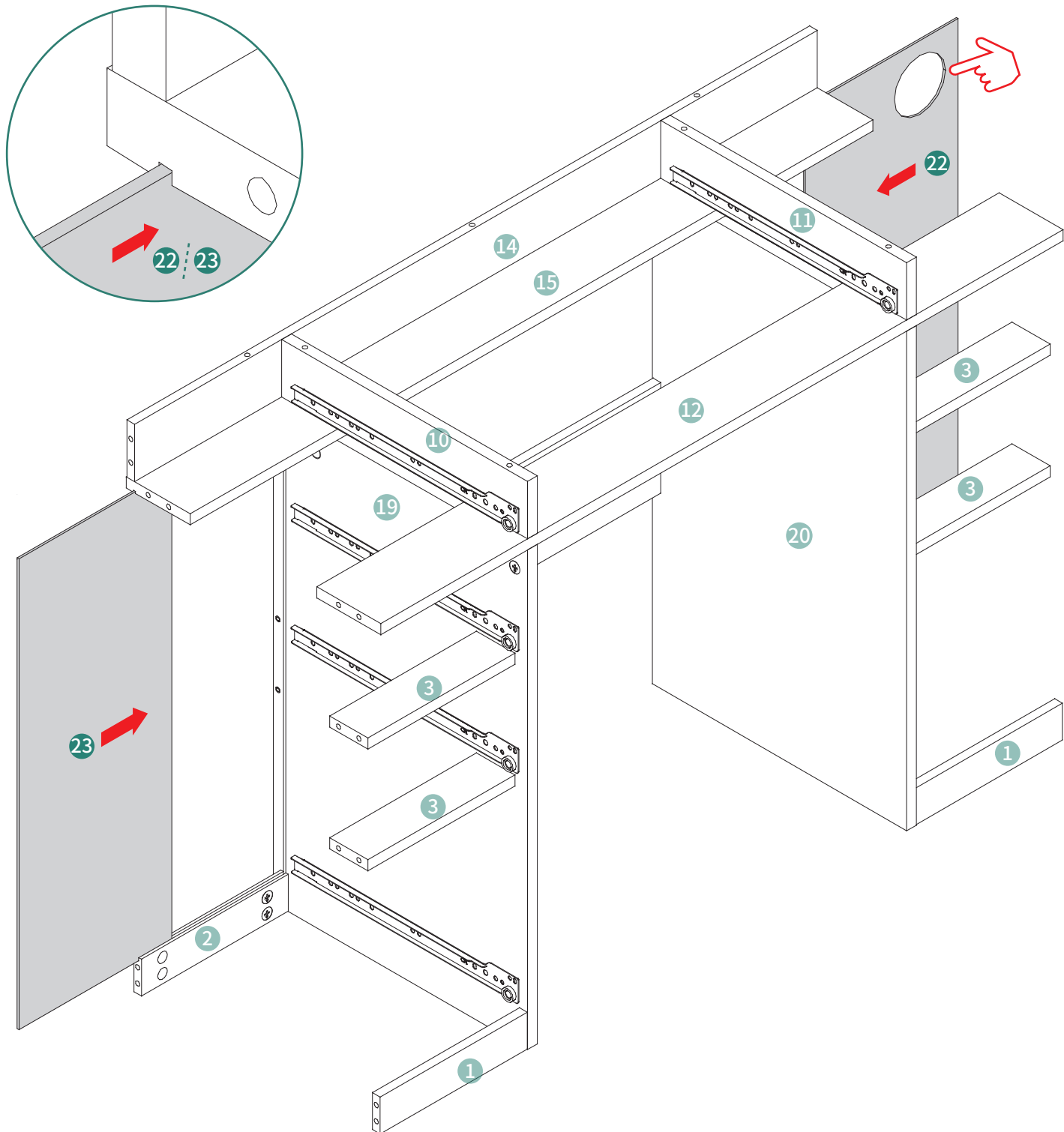

20

φ15 X 12mm φ15 X 9mm



(B) 8pcs (C) 6pcs

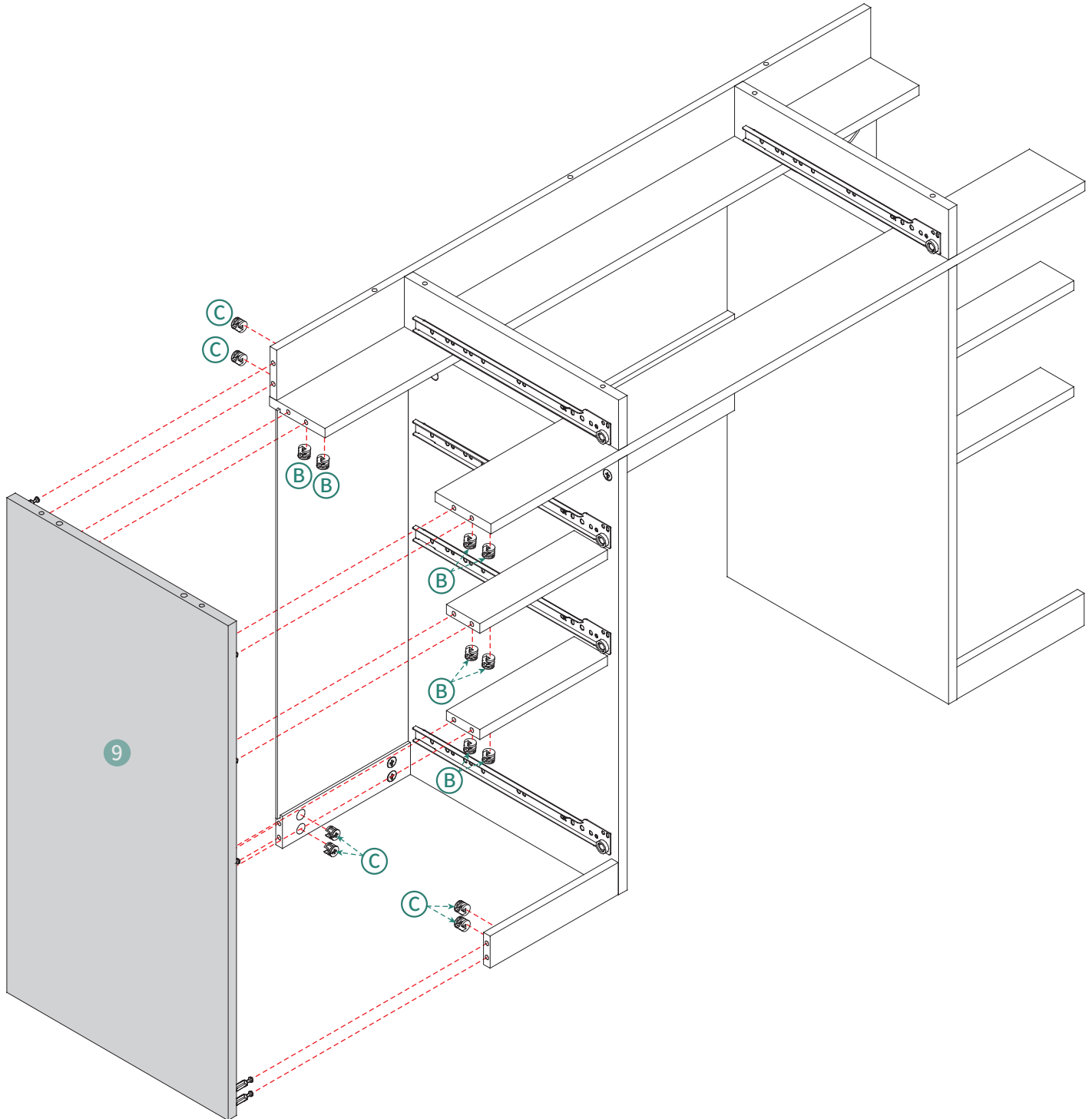
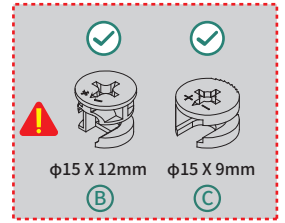

# 21

φ15 X 12mm    φ15 X 9mm



(B) 8pcs    (C) 6pcs

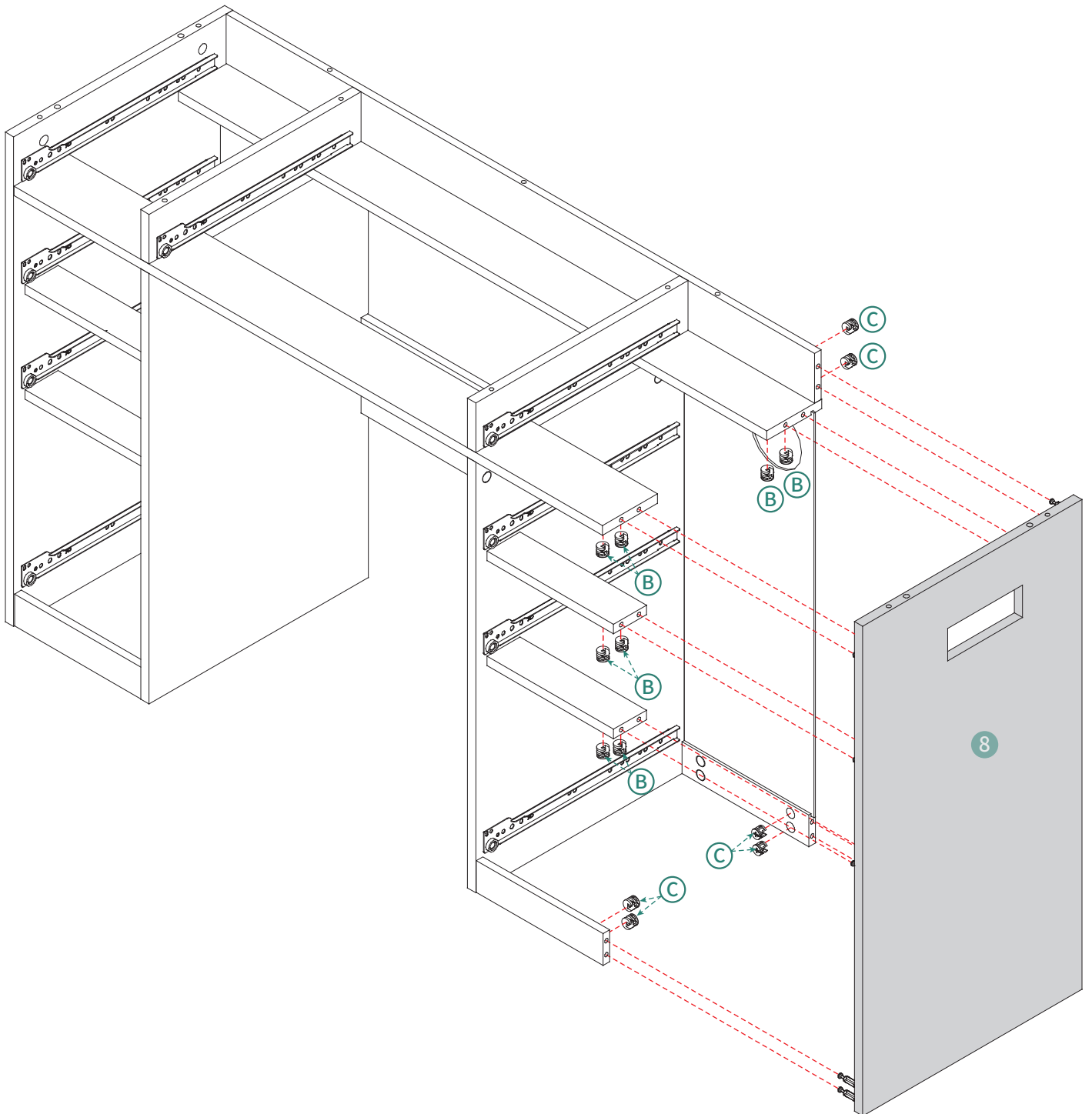
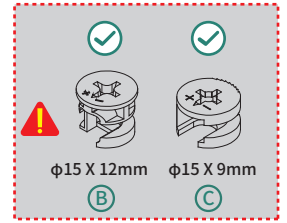

# 22

φ15 X 12mm

φ8 X 40mm

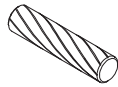

Ⓑ8pcs

Ⓓ4pcs

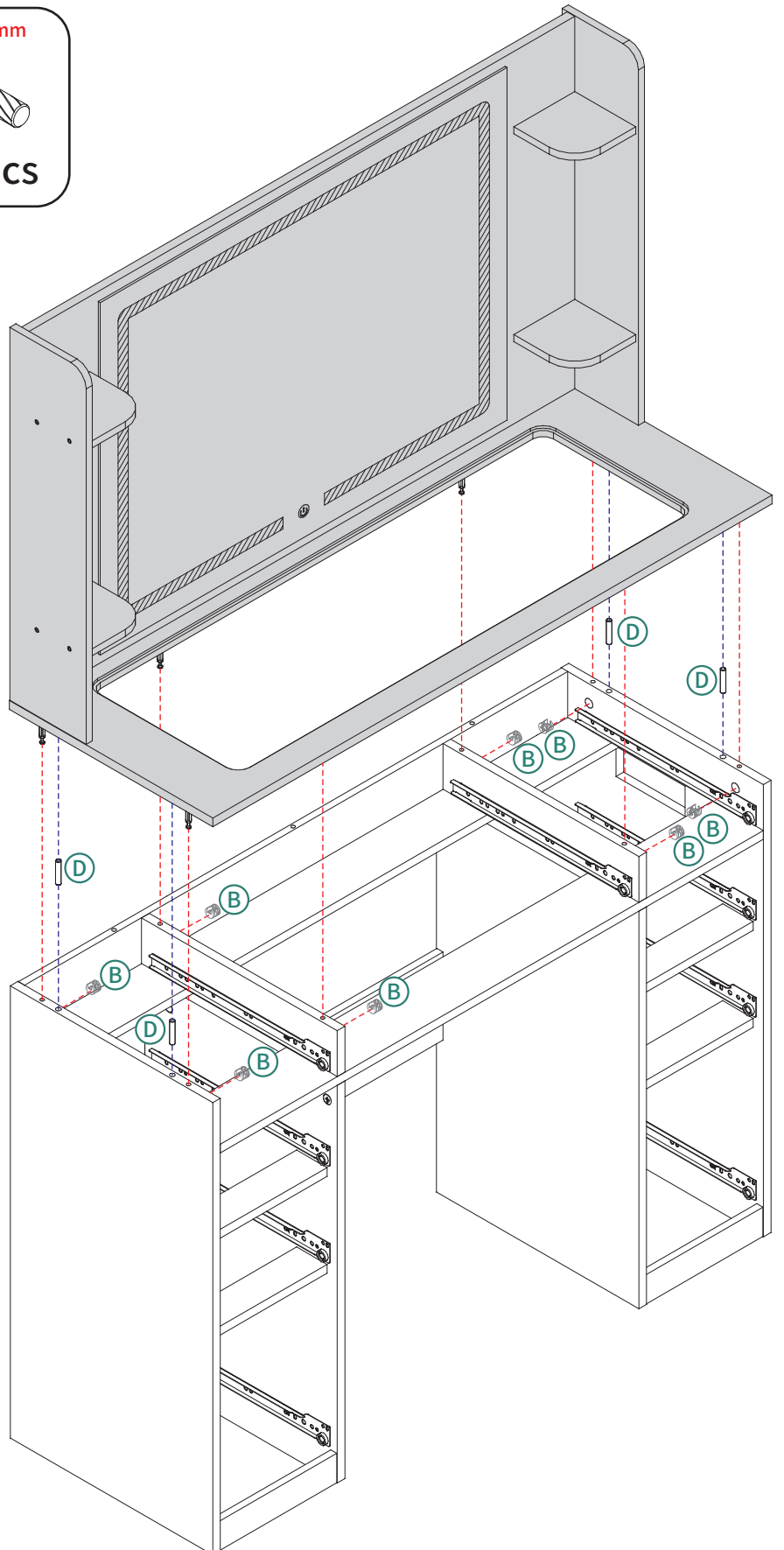

23

φ15 X 9mm



ⓐ3pcs

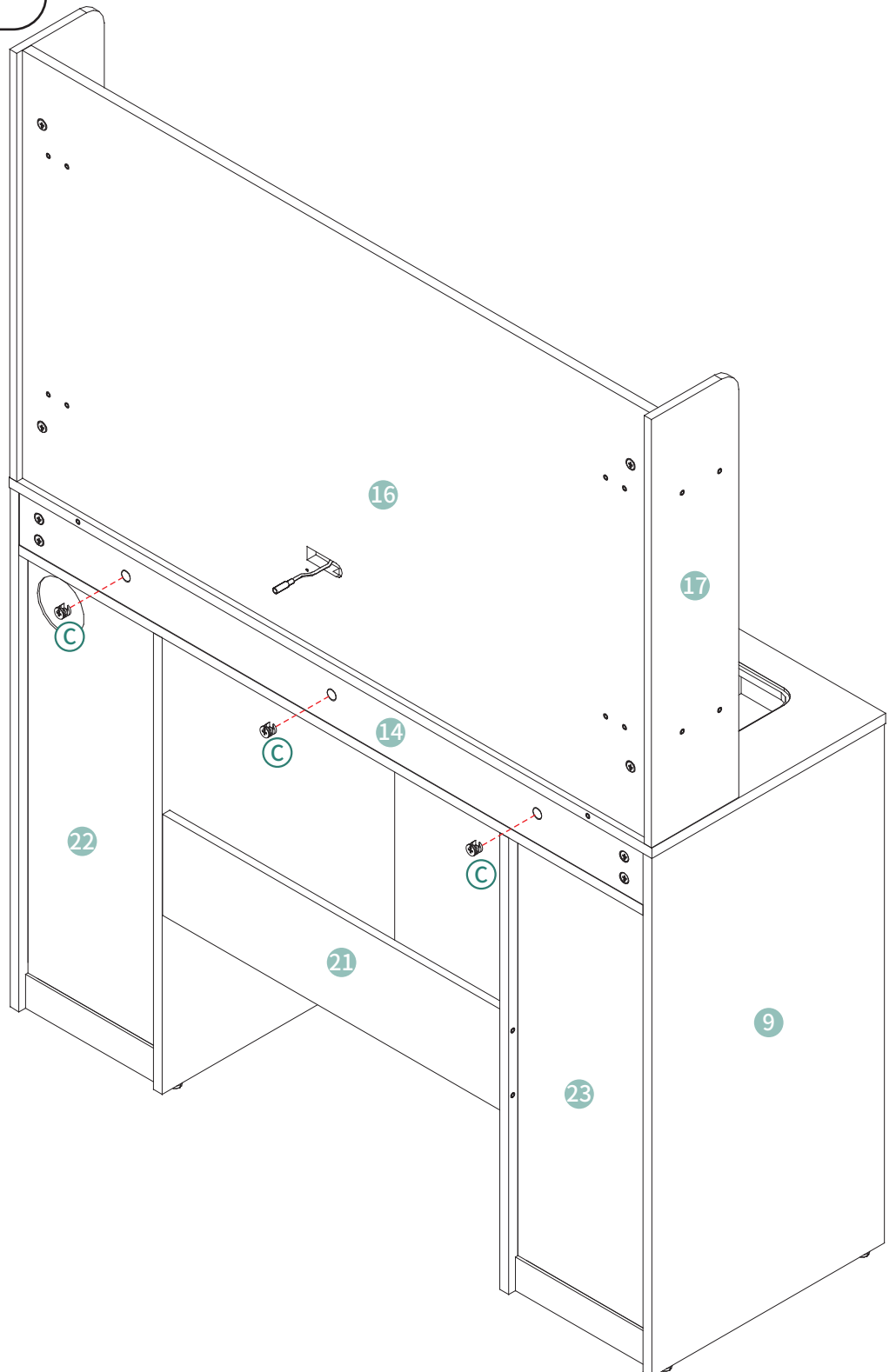
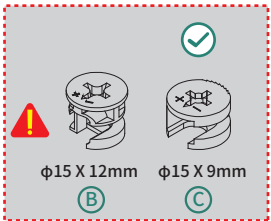

**24**

ST3.5 X 14mm



Ⓔ8pcs Ⓜ8pcs

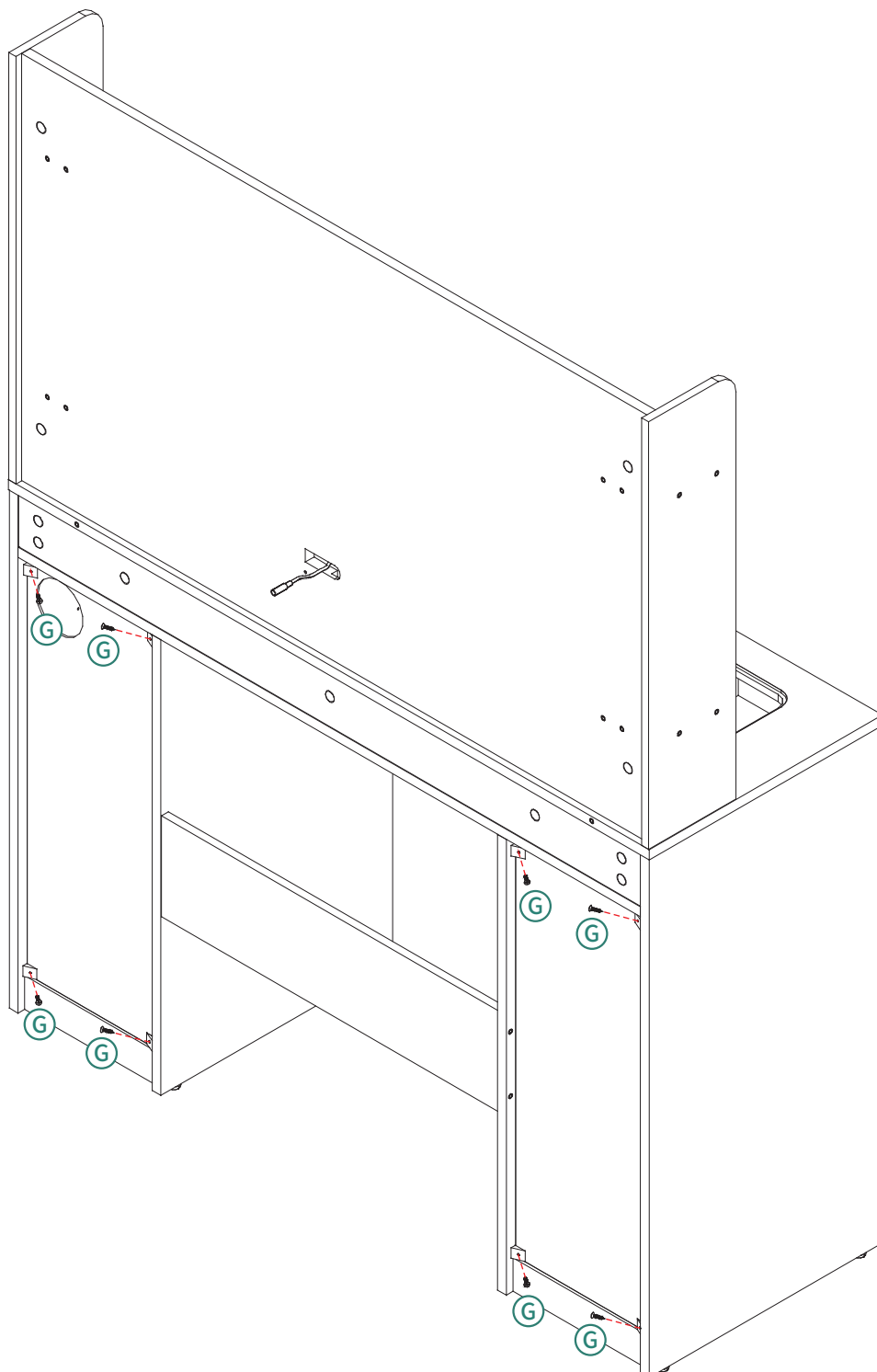
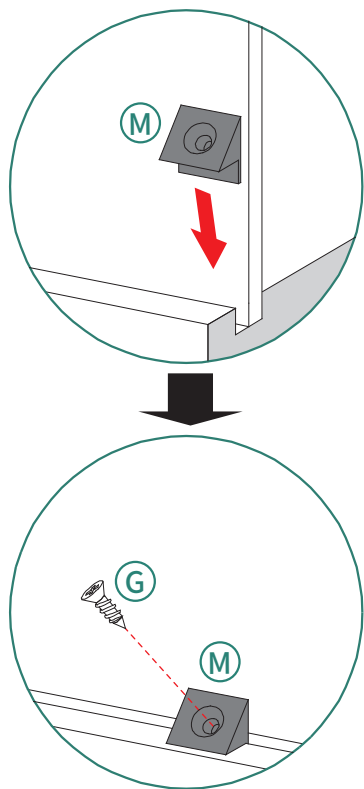

# 25

ST3.5 X 14mm



ⓐ4pcs Ⓝ1pc Ⓞ1pc

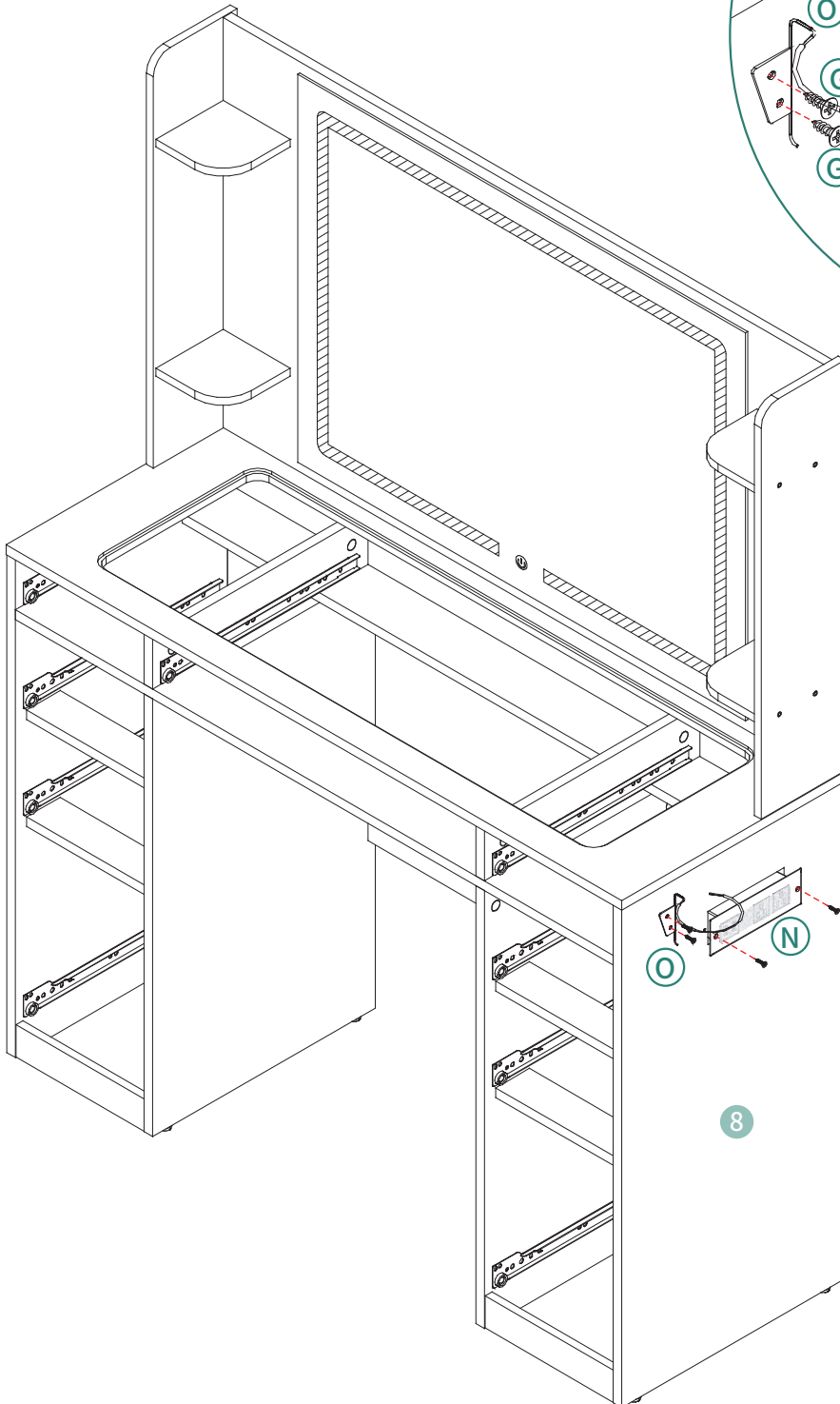
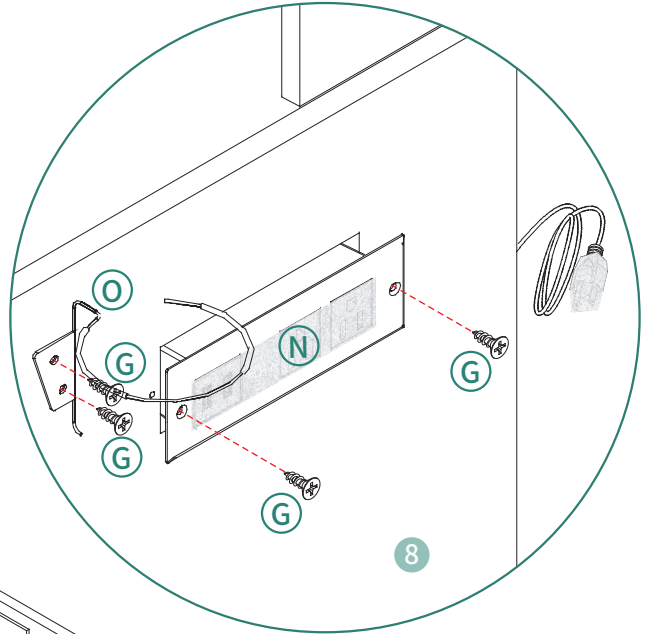

# 26

## X2

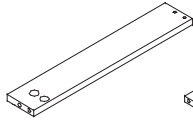

②52pcs

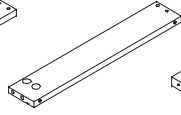

②82pcs

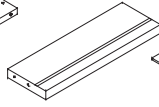

③22pcs

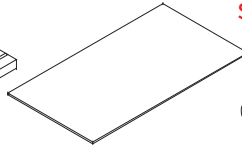

③52pcs

ST3.5 X 35mm

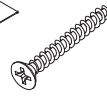

Ⓜ8pcs

Note: Make sure the positions marked by triangles are facing the same direction.

Hinweis: Stellen Sie sicher, dass die Positionen, die durch Dreiecke markiert sind, in die gleiche Richtung zeigen.

Note : Assurez-vous que les positions marquées par des triangles sont orientées dans la même direction.

Nota: Assicurati che le posizioni contrassegnate da triangoli siano rivolte nella stessa direzione.

Nota: Asegúrate de que las posiciones marcadas con triángulos estén orientadas en la misma dirección.

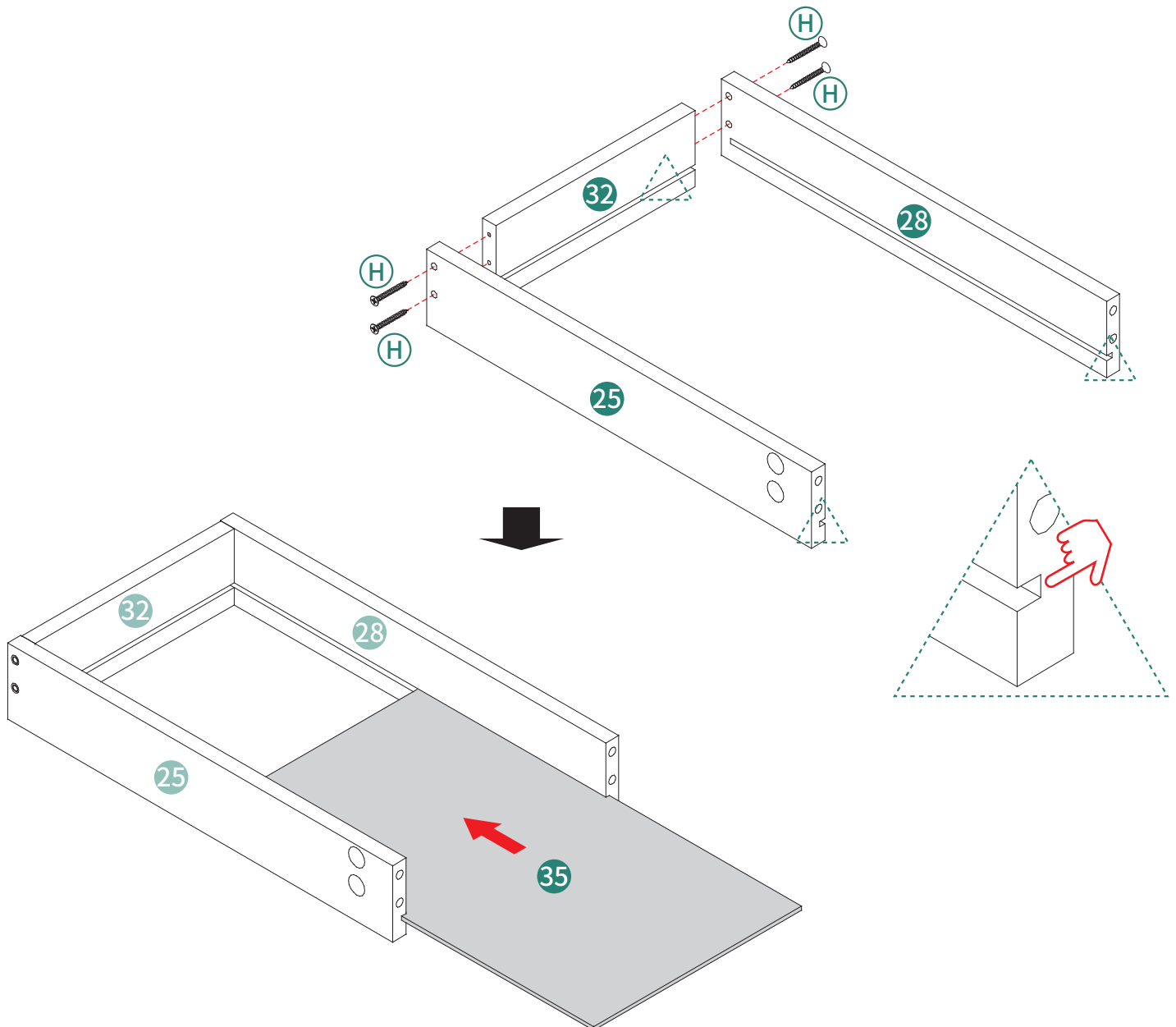

# 27

## X2

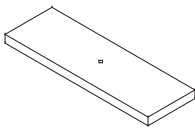

36 2pcs

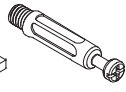

A 8pcs

φ15 X 9mm



C 8pcs



J 2pcs

M4 X 15mm

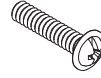

K 2pcs

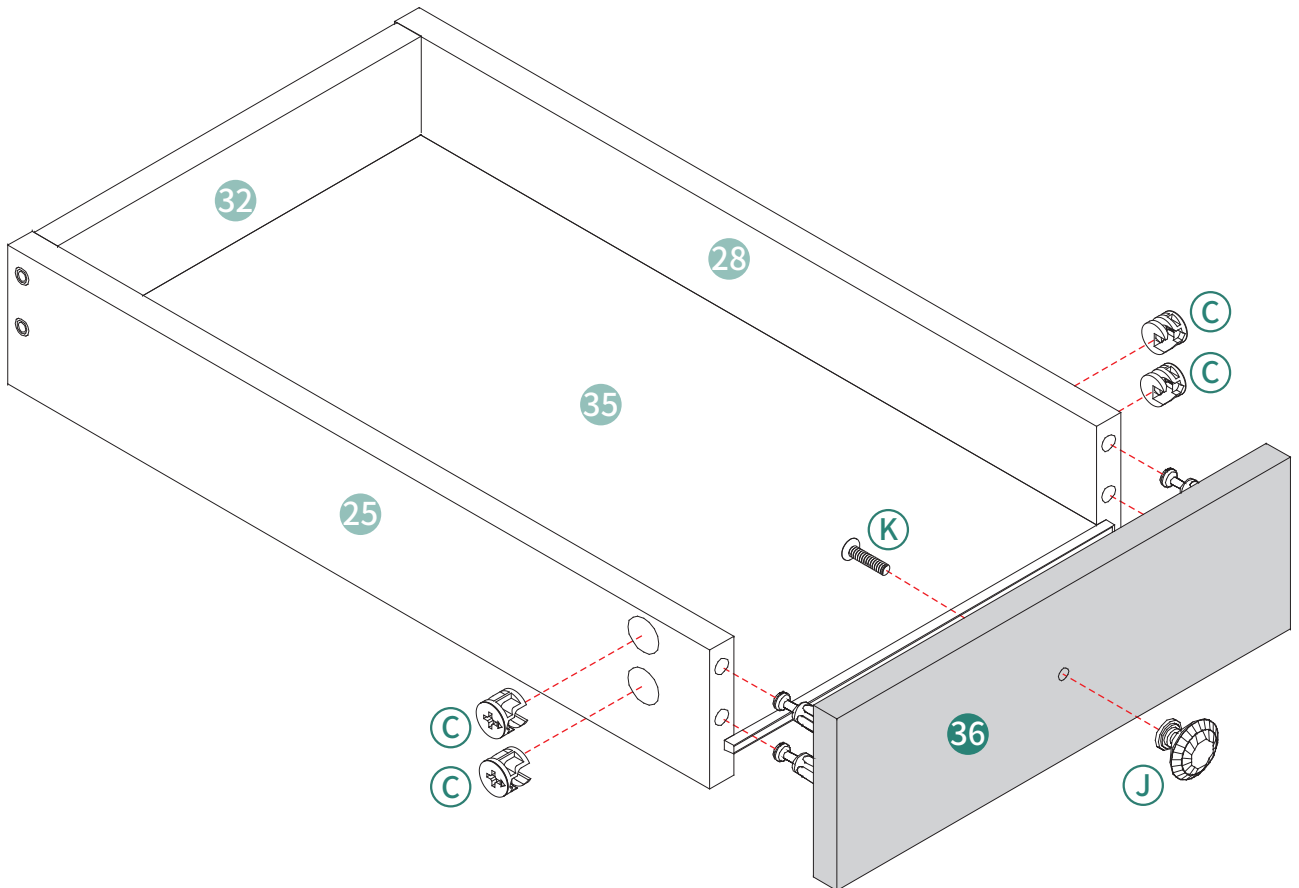
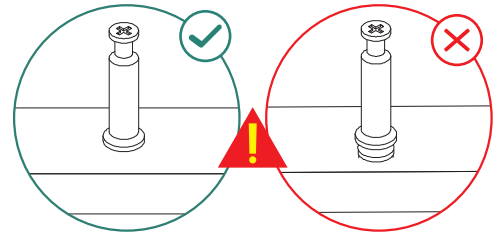
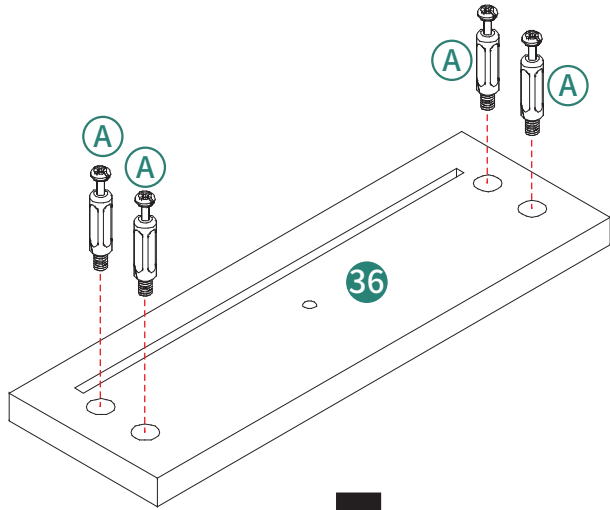
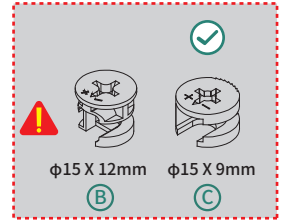

**28**  
**X2**

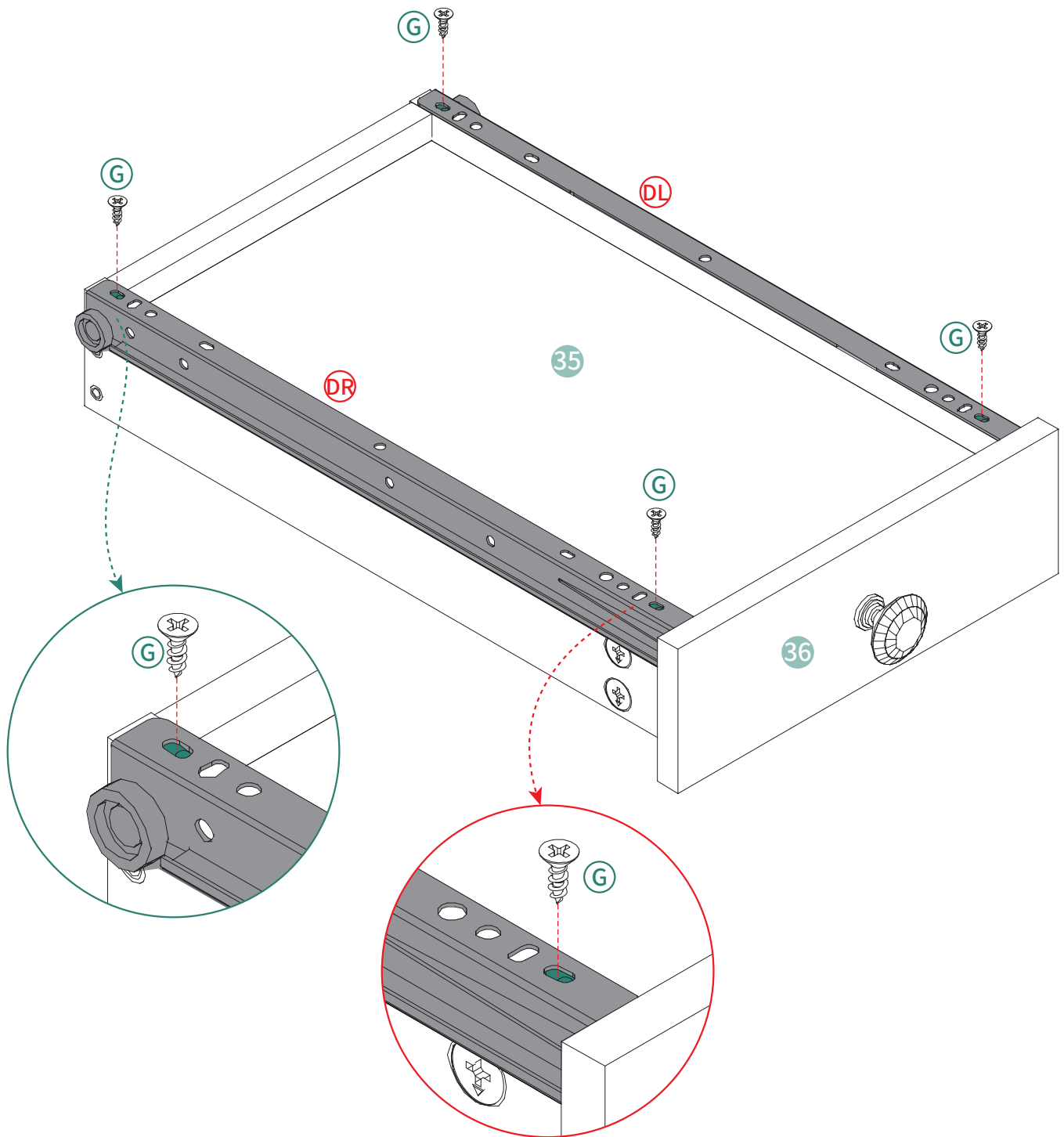
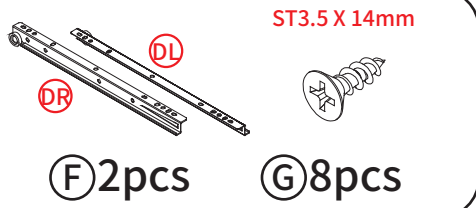

# 29

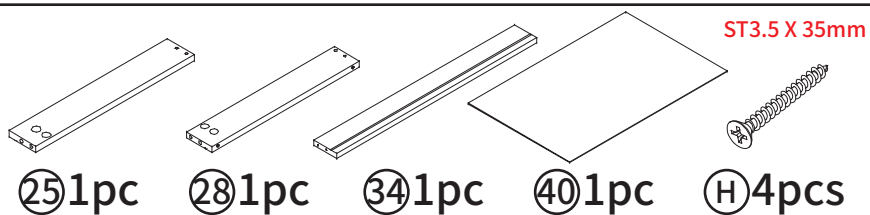

Note: Make sure the positions marked by triangles are facing the same direction.

Hinweis: Stellen Sie sicher, dass die Positionen, die durch Dreiecke markiert sind, in die gleiche Richtung zeigen.

Note : Assurez-vous que les positions marquées par des triangles sont orientées dans la même direction.

Nota: Assicurati che le posizioni contrassegnate da triangoli siano rivolte nella stessa direzione.

Nota: Asegúrate de que las posiciones marcadas con triángulos estén orientadas en la misma dirección.

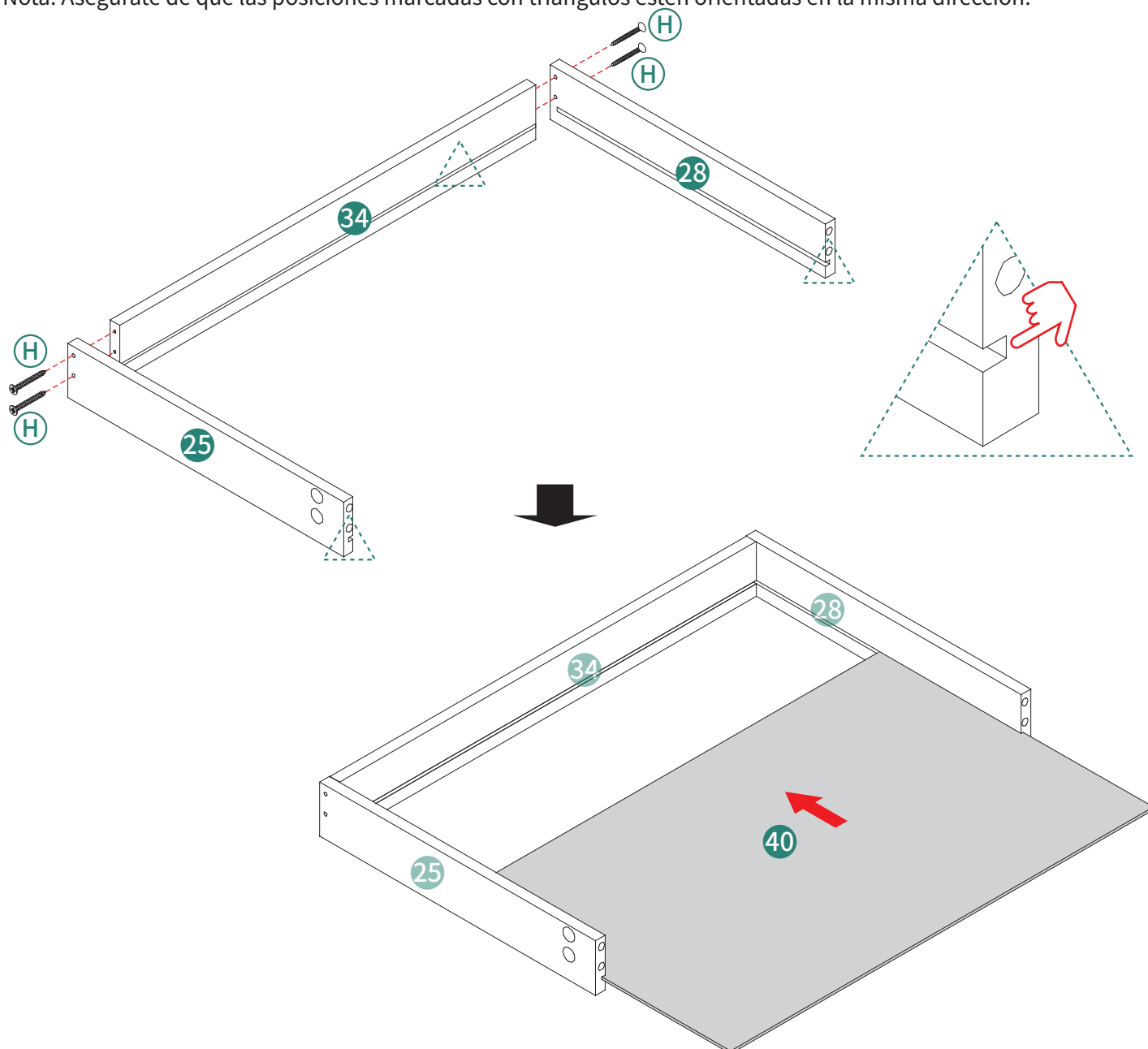

# 30

$\phi 15 \times 9 \text{mm}$   $M4 \times 15 \text{mm}$

③9 1pc    ④A 4pcs    ⑤C 4pcs    ⑥J 1pc    ⑦K 1pc

⚠️  $\phi 15 \times 12 \text{mm}$  (B)  $\phi 15 \times 9 \text{mm}$  (C)

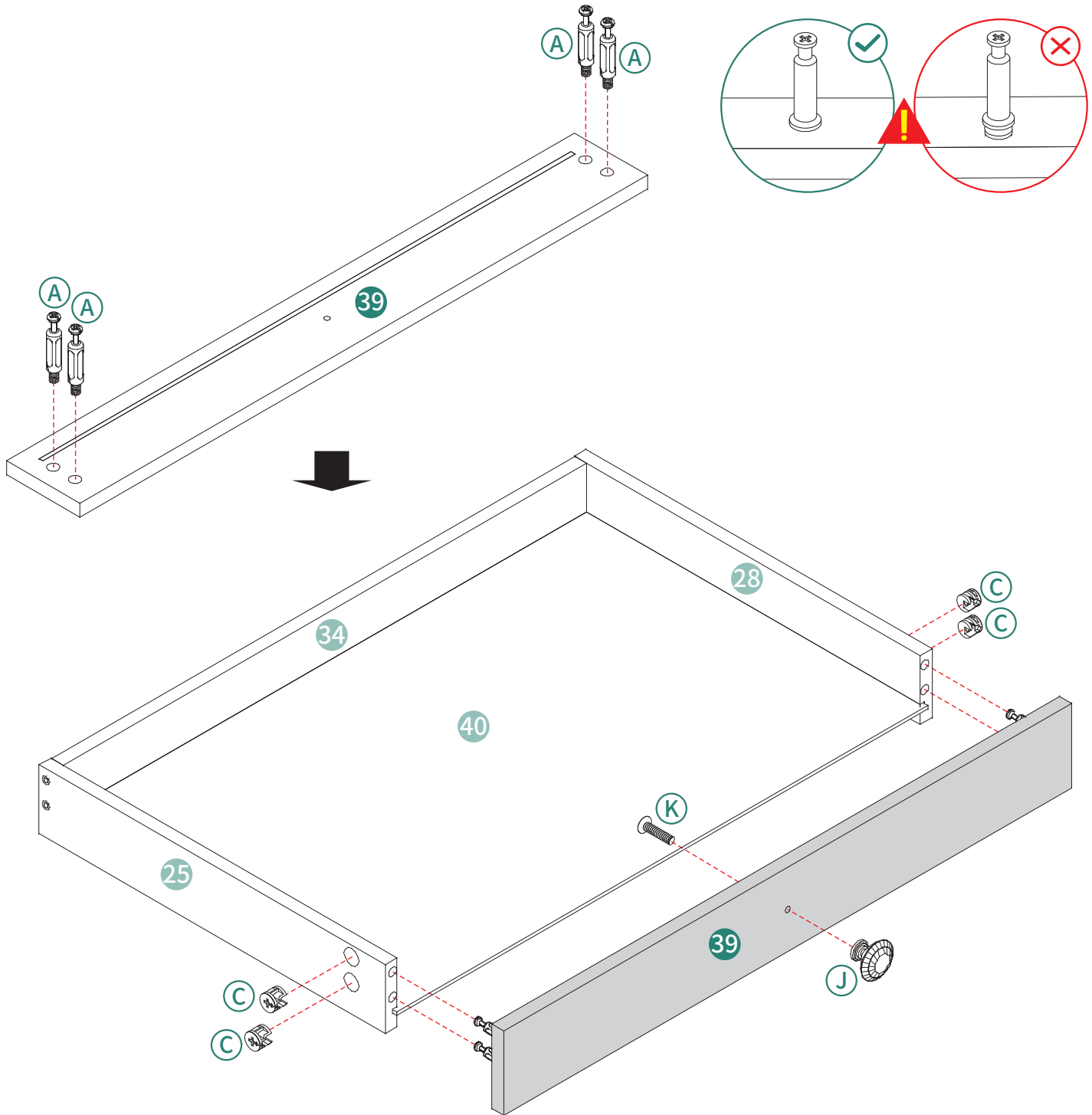

# 31

ST3.5 X 14mm

DL  
DR

F 1pc G 4pcs

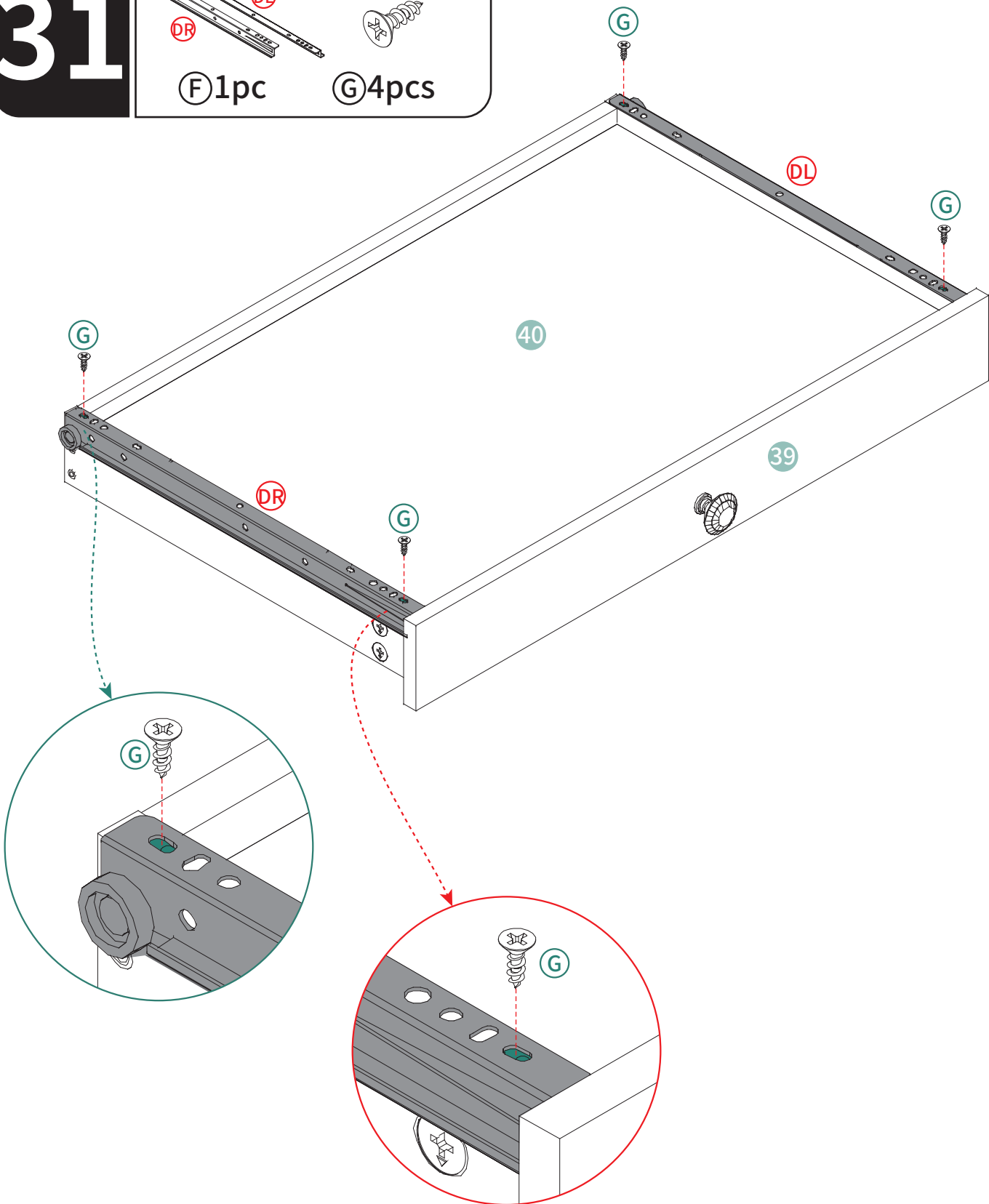

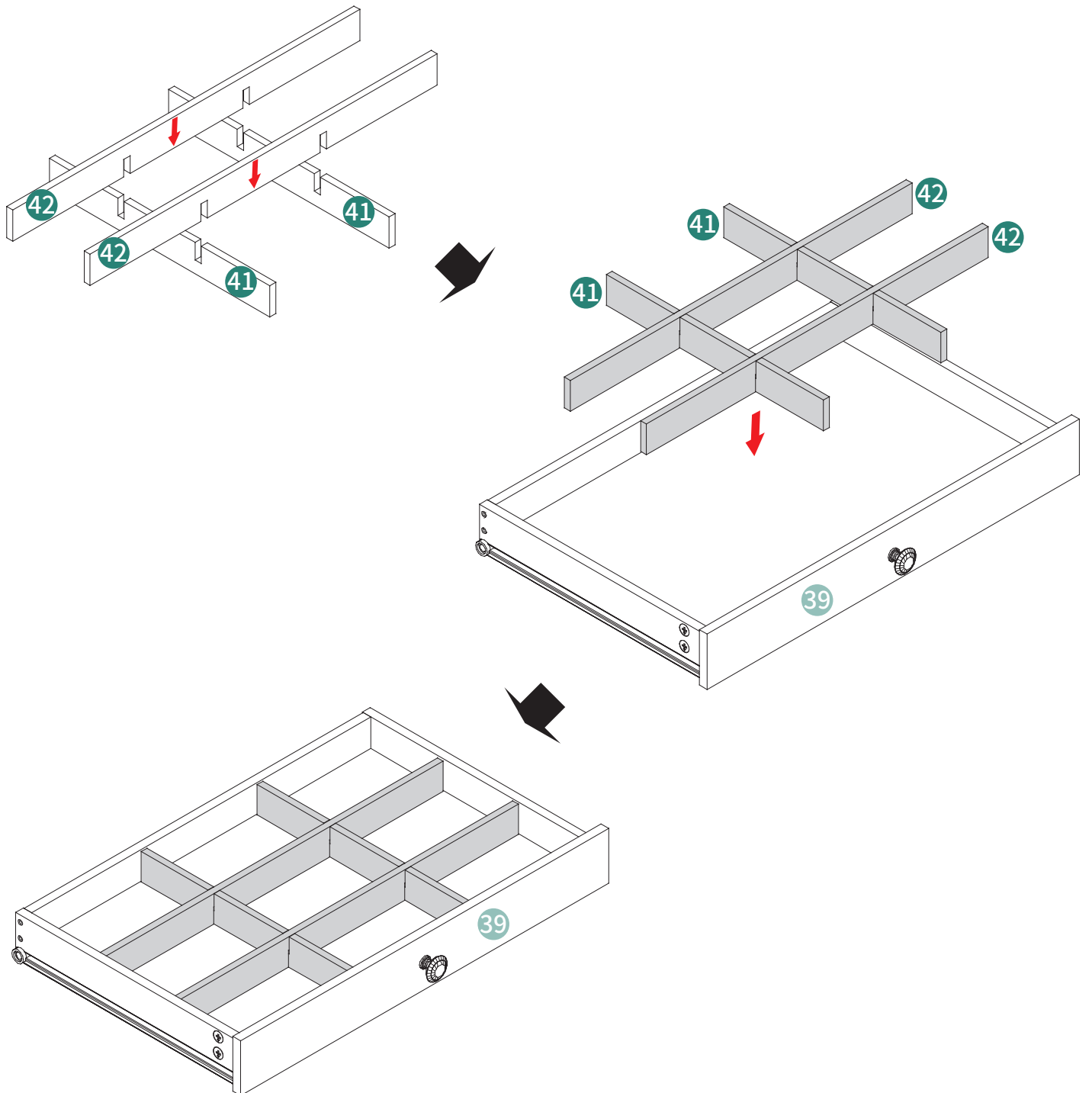
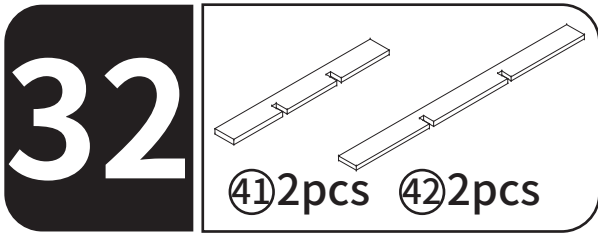

# 33

## X4

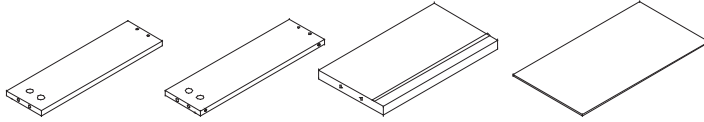

ST3.5 X 35mm

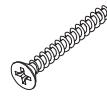

②6 4pcs   ②9 4pcs   ③3 4pcs   ③5 4pcs   (H) 16pcs

Note: Make sure the positions marked by triangles are facing the same direction.

Hinweis: Stellen Sie sicher, dass die Positionen, die durch Dreiecke markiert sind, in die gleiche Richtung zeigen.

Note : Assurez-vous que les positions marquées par des triangles sont orientées dans la même direction.

Nota: Assicurati che le posizioni contrassegnate da triangoli siano rivolte nella stessa direzione.

Nota: Asegúrate de que las posiciones marcadas con triángulos estén orientadas en la misma dirección.

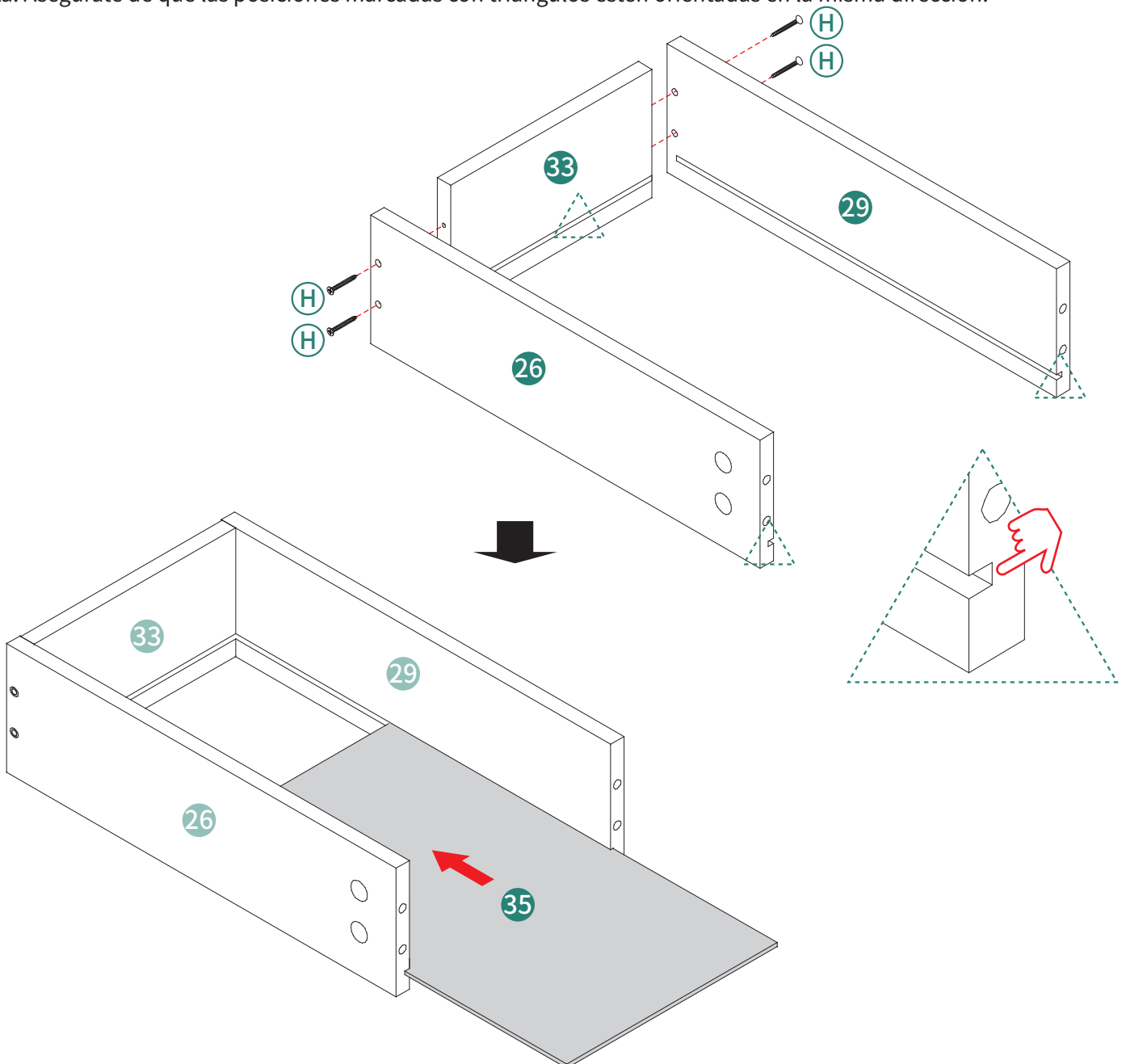

**34**  
**X4**

$\phi 15 \times 9\text{mm}$   $M4 \times 15\text{mm}$

38 4pcs A 16pcs C 16pcs J 4pcs K 4pcs

$\phi 15 \times 12\text{mm}$   $\phi 15 \times 9\text{mm}$

B C

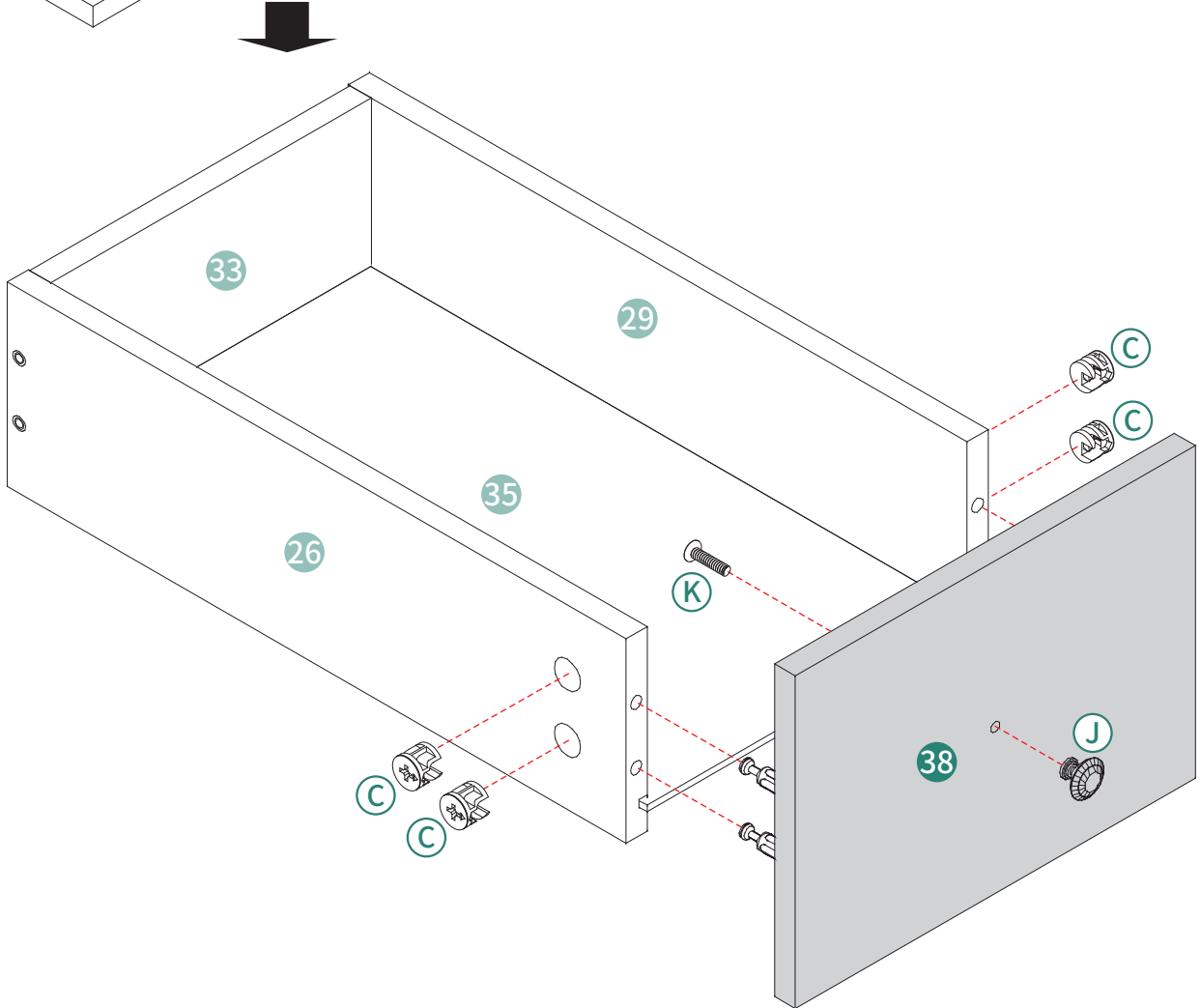
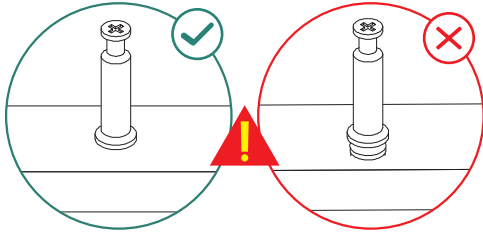
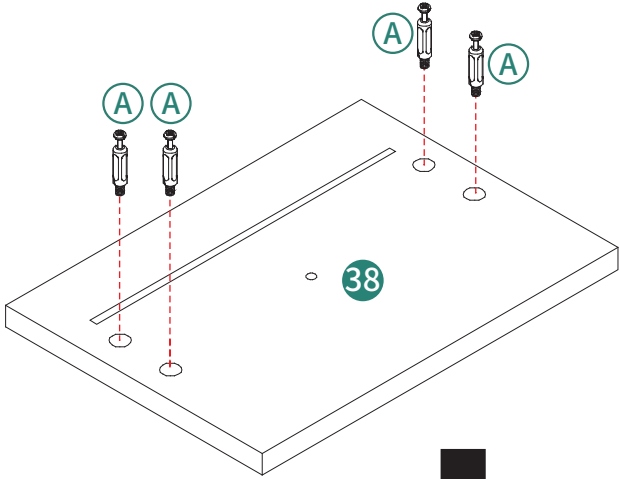

**35**  
**X4**

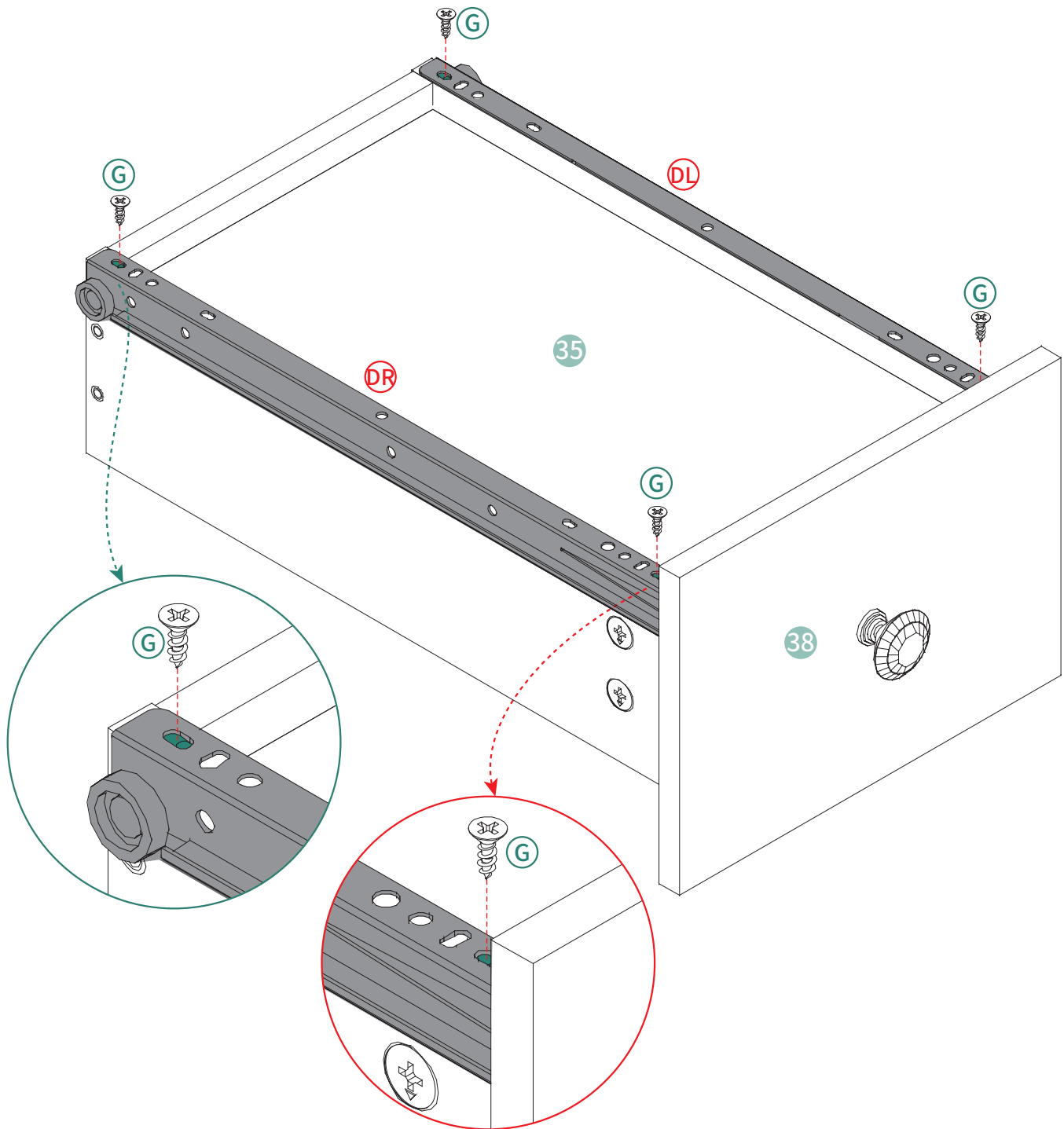
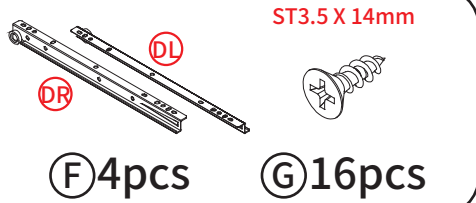

# 36

## X2

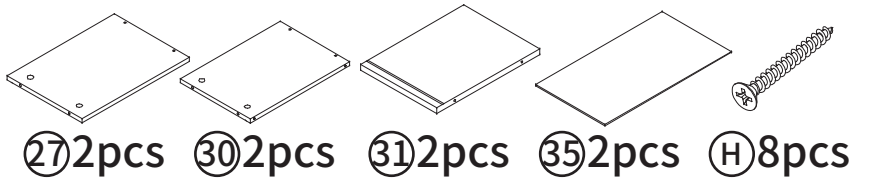

Note: Make sure the positions marked by triangles are facing the same direction.

Hinweis: Stellen Sie sicher, dass die Positionen, die durch Dreiecke markiert sind, in die gleiche Richtung zeigen.

Note : Assurez-vous que les positions marquées par des triangles sont orientées dans la même direction.

Nota: Assicurati che le posizioni contrassegnate da triangoli siano rivolte nella stessa direzione.

Nota: Asegúrate de que las posiciones marcadas con triángulos estén orientadas en la misma dirección.

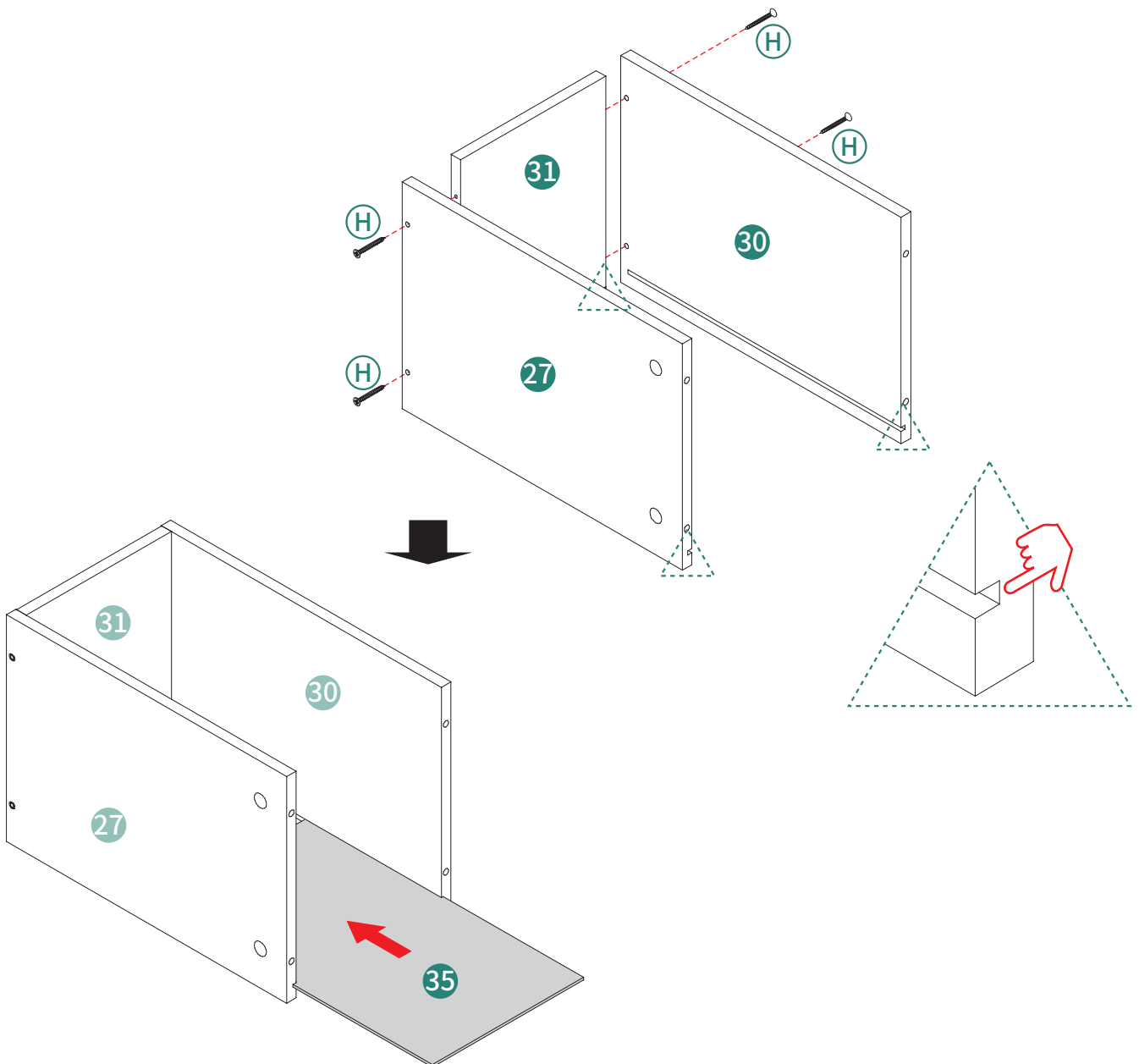

**37**  
**X2**

$\phi 15 \times 9\text{mm}$   $M4 \times 15\text{mm}$

37 2pcs A 8pcs C 8pcs J 2pcs K 2pcs

$\phi 15 \times 12\text{mm}$   $\phi 15 \times 9\text{mm}$

B C

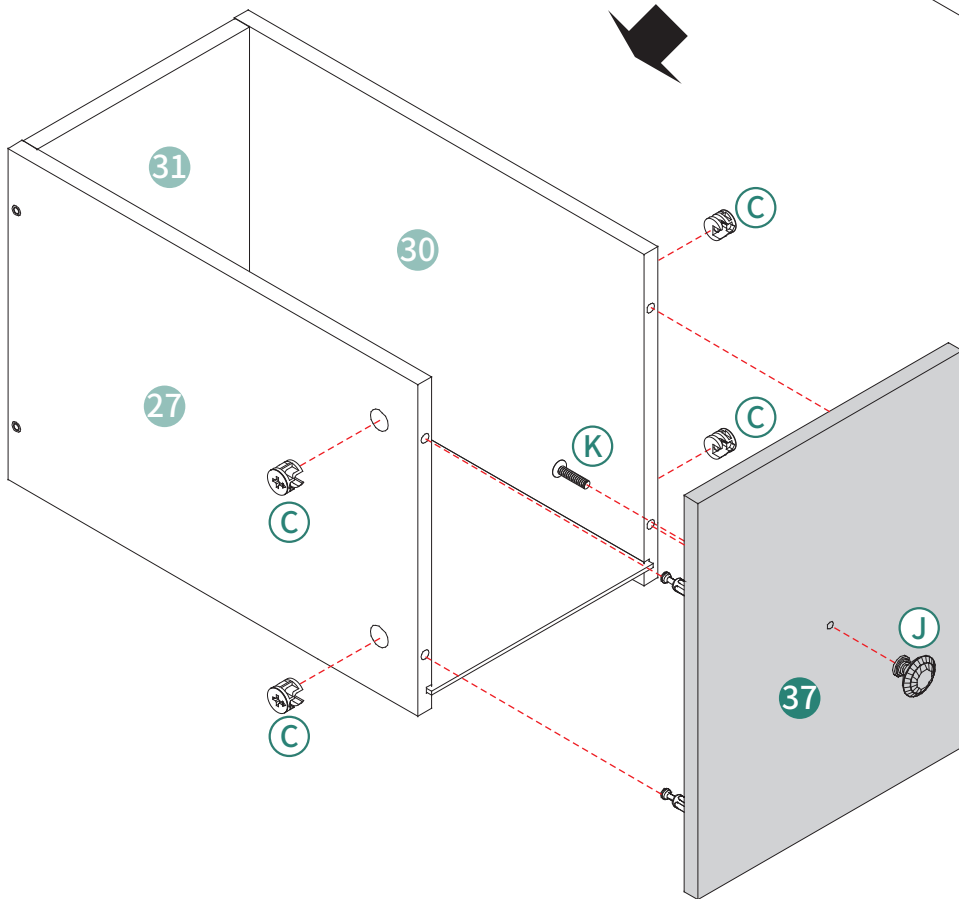
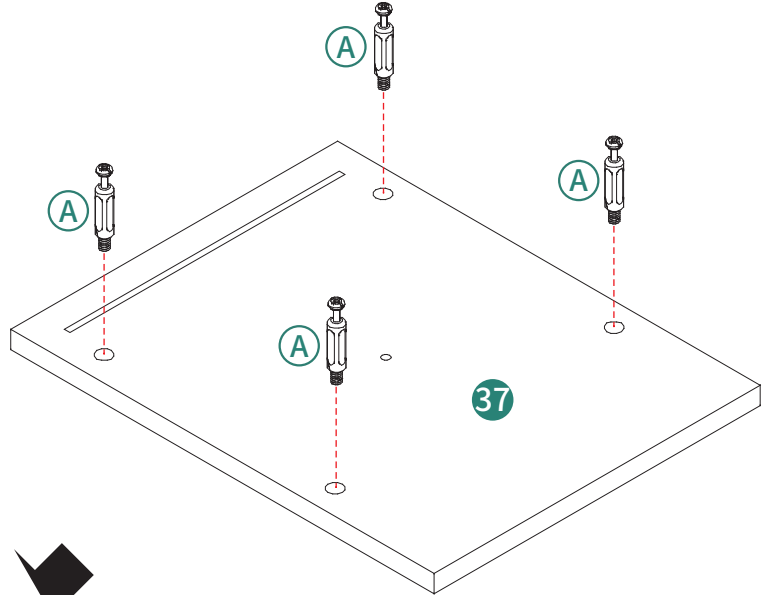
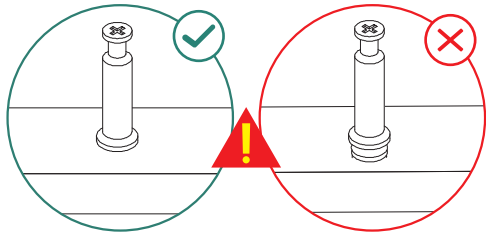

**38**  
**X2**

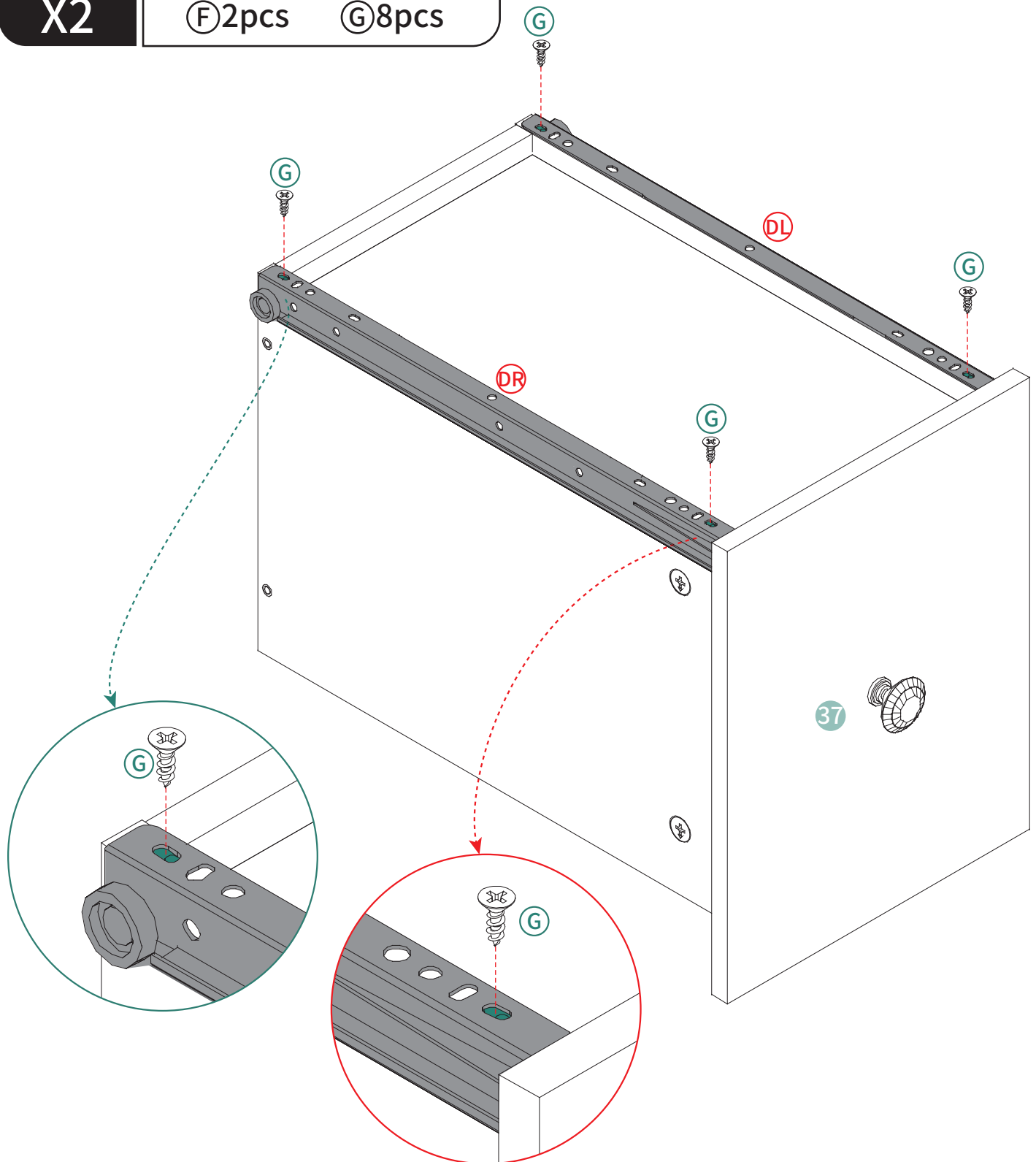
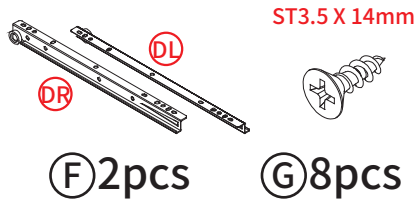

# 39

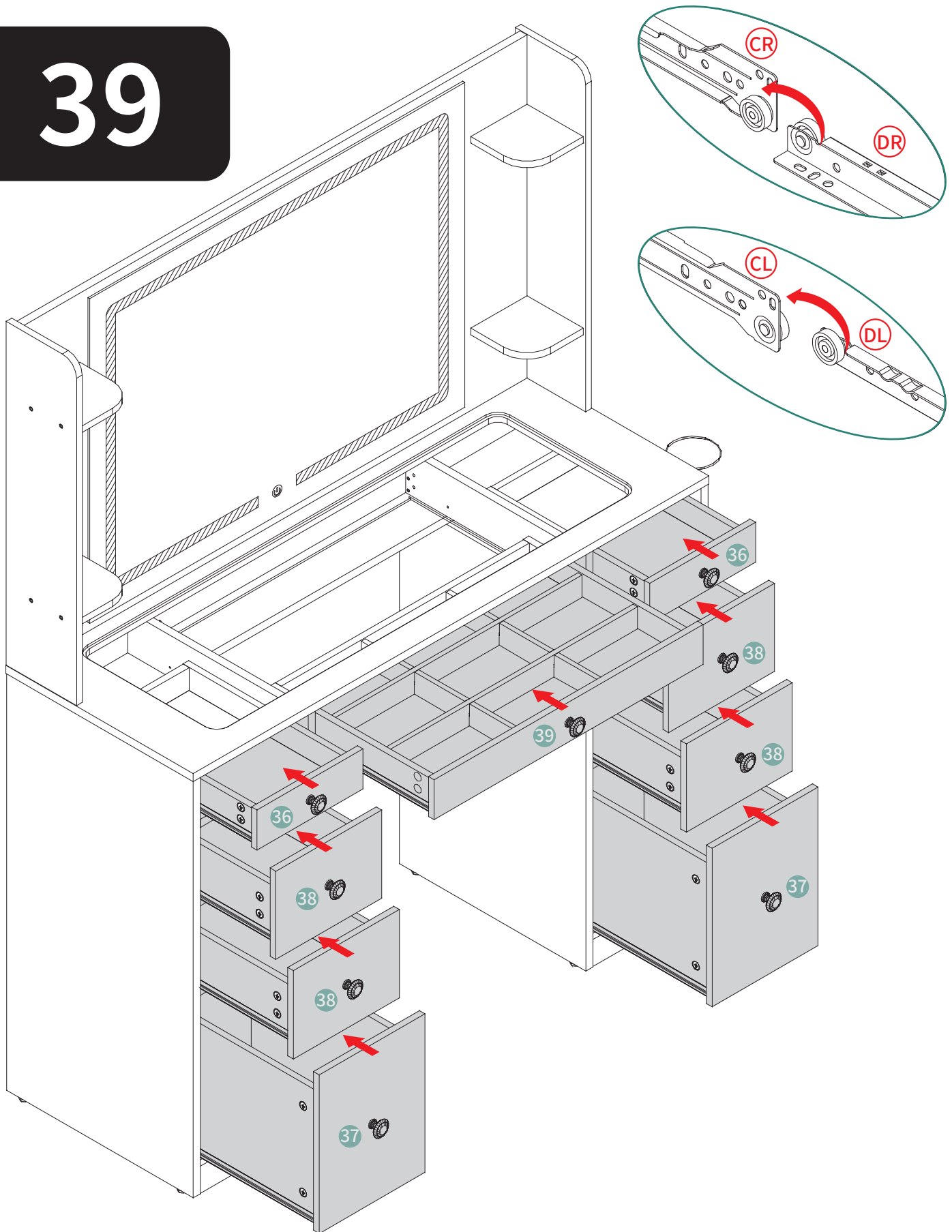

**40**

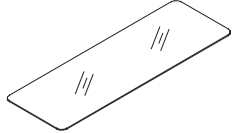

241pc

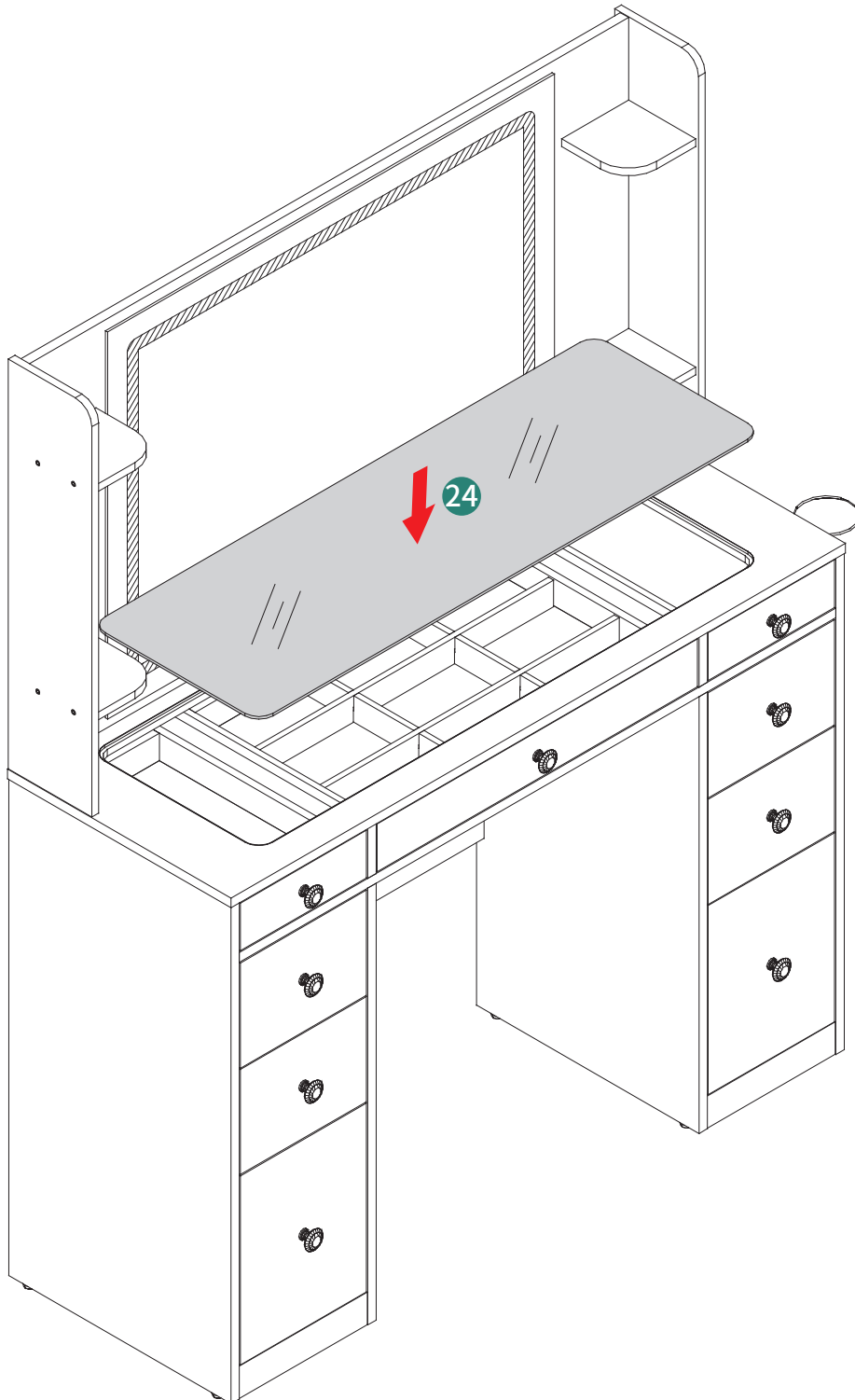

**41**

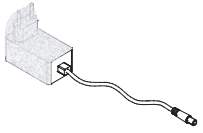

Ⓢ1pc

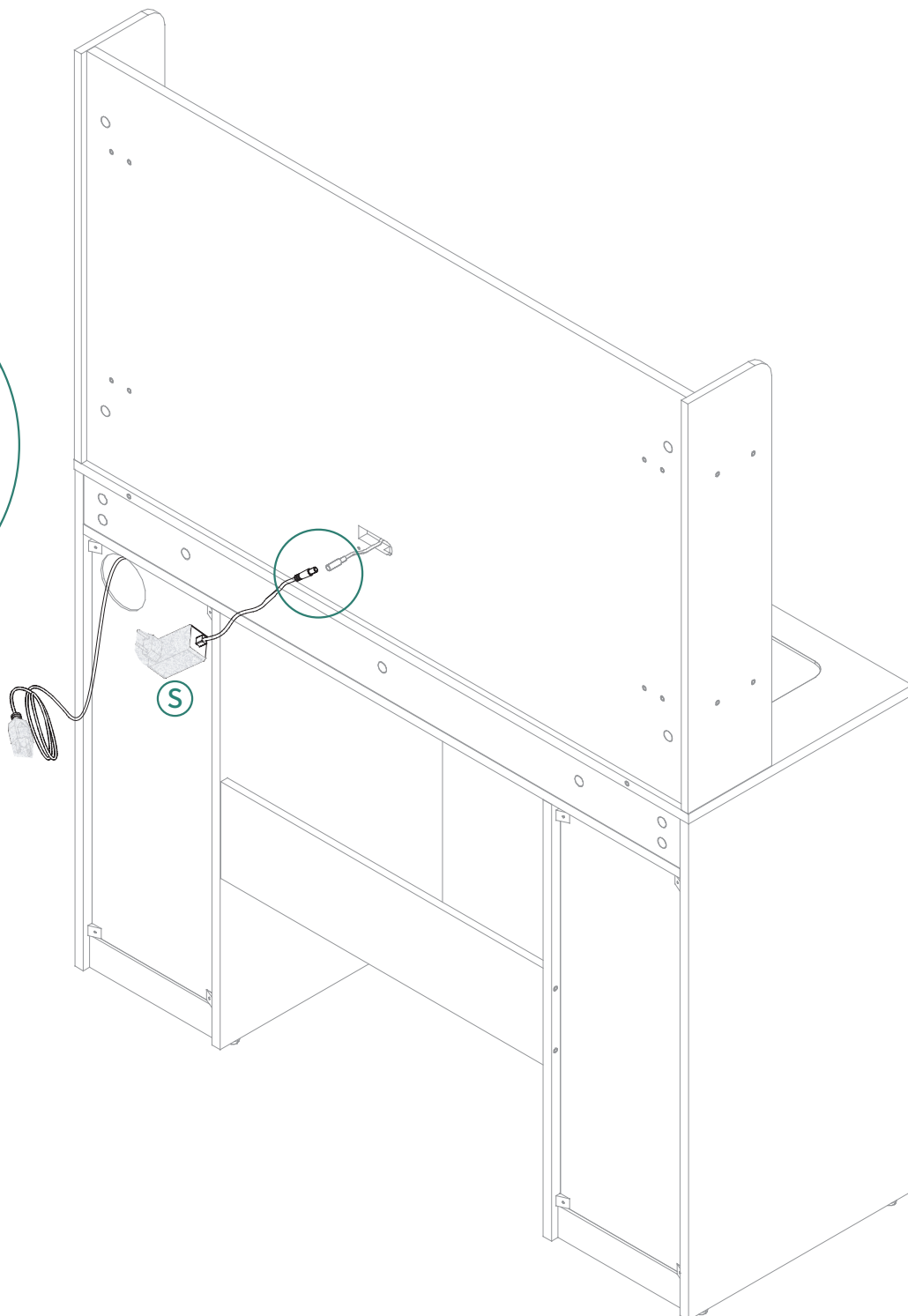
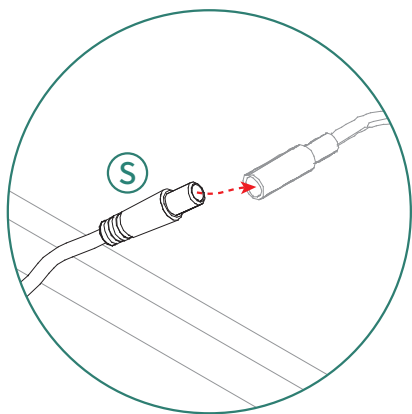

# 42

ST3.5 X 14mm

ST4 X 30mm



ⓐ2pcs



Ⓚ2pcs

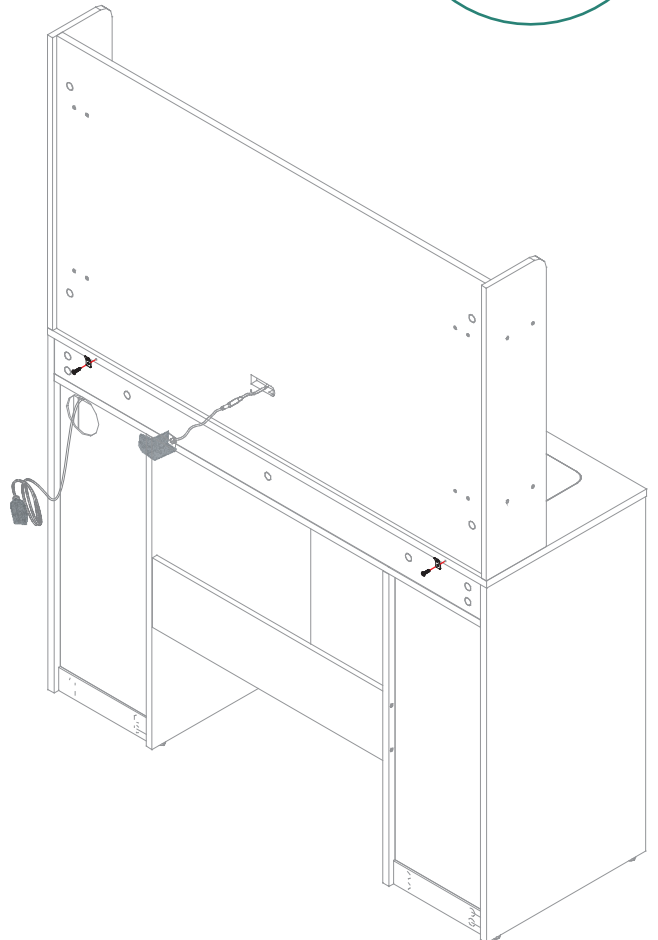
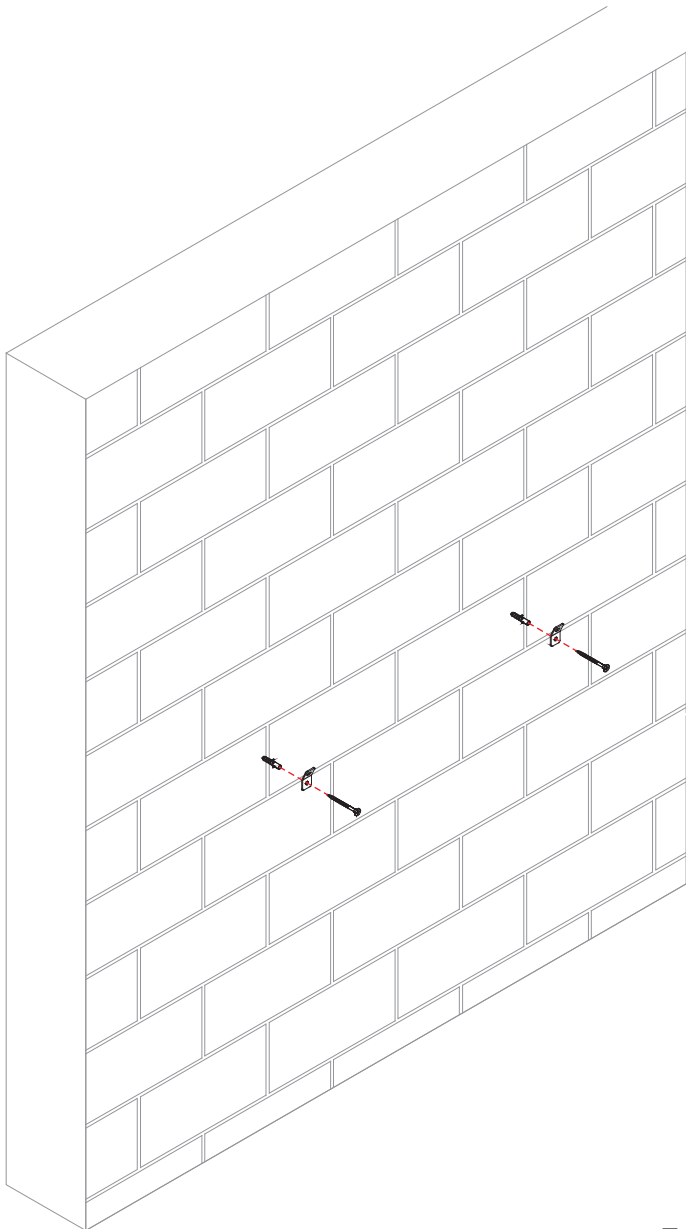
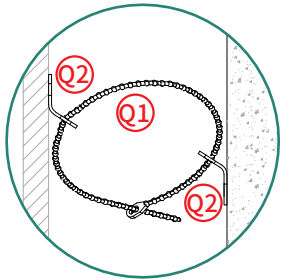
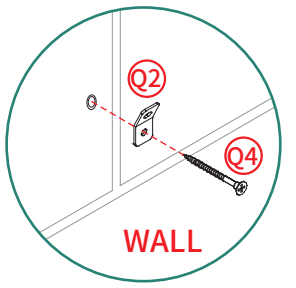
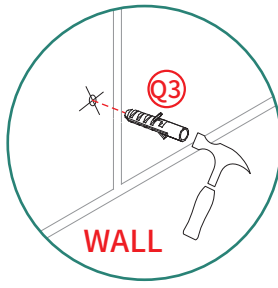
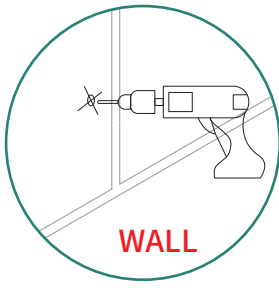
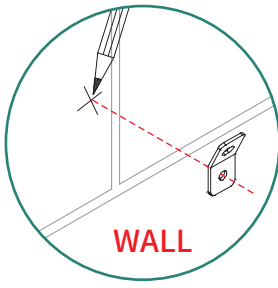
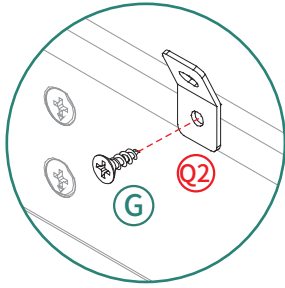

43

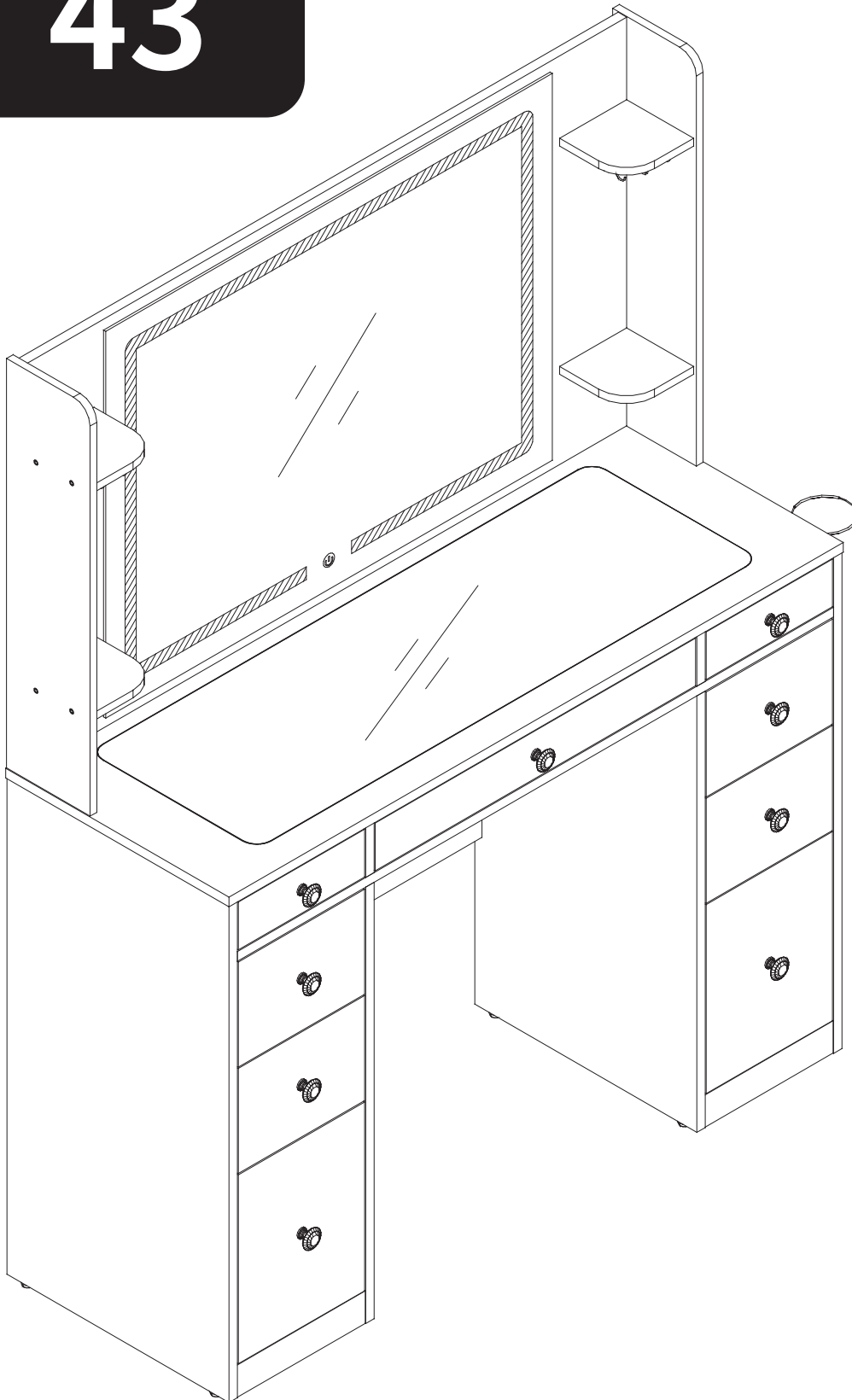

Installation Completed

Installation Abgeschlossen

Installation Complétée

Installazione Completata

Instalación Completada

## DISCLAIMER

Manufacturer and seller expressly disclaim any and all liability for personal injury, property damage or loss, whether direct, indirect, or incidental, resulting from the incorrect attachment, improper use, inadequate maintenance, unapproved modification, or neglect of this product.

Der Hersteller und Verkäufer lehnen ausdrücklich jegliche Haftung für Personenschäden, Sachschäden oder Verluste ab, egal ob direkt, indirekt oder zufällig, die durch falsche Anbringung, unsachgemäßen Gebrauch, unzureichende Wartung, nicht genehmigte Änderungen oder Vernachlässigung dieses Produkts entstehen.

El fabricante y vendedor renuncian expresamente a toda responsabilidad por lesiones personales, daños materiales o pérdidas, ya sean directos, indirectos o incidentales, derivados de la incorrecta colocación, uso inadecuado, mantenimiento insuficiente, modificación no aprobada o negligencia de este producto.

Il produttore e il venditore declinano espressamente ogni responsabilità per lesioni personali, danni materiali o perdite, dirette, indirette o incidentali, derivanti dall'errato fissaggio, uso improprio, manutenzione inadeguata, modifica non autorizzata o negligenza di questo prodotto.

Le fabricant et le vendeur déclinent expressément toute responsabilité en cas de blessures corporelles, de dommages matériels ou de pertes, qu'ils soient directs, indirects ou accessoires, résultant de la fixation incorrecte, de l'utilisation inappropriée, de l'entretien insuffisant, de la modification non approuvée ou de la négligence de ce produit.