

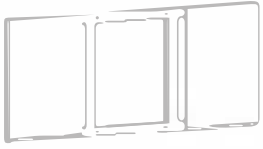

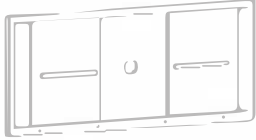





ASSEMBLY INSTRUCTIONS

Ax1 	Bx1 	Cx1 	Dx4 
Ex4 	Fx7 	Gx7 	Hx32 
Ix30 	Jx7 	EXTRA HARDWARE Hx2 Ix2	

Note

- EN: 1. Please do not tight any bolt unless all bolts are fixed at their respective places
2. After fixing the bolts tighten them simultaneously.
3. Matching Parts Bolt (example A to A)
4. Two person assembly required.

STEP - 01

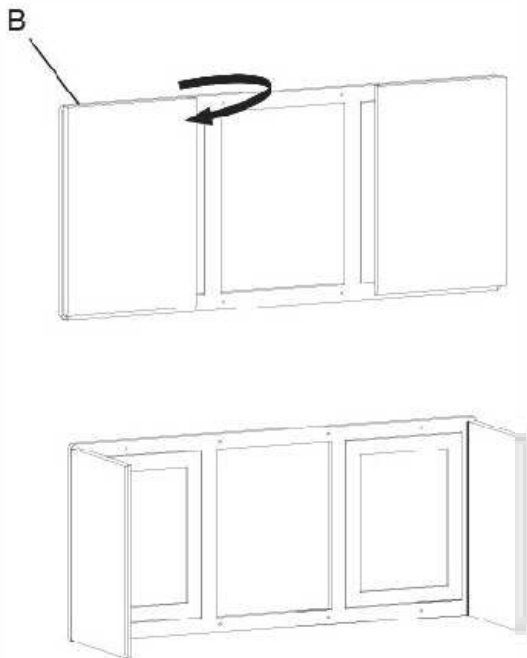

STEP - 02

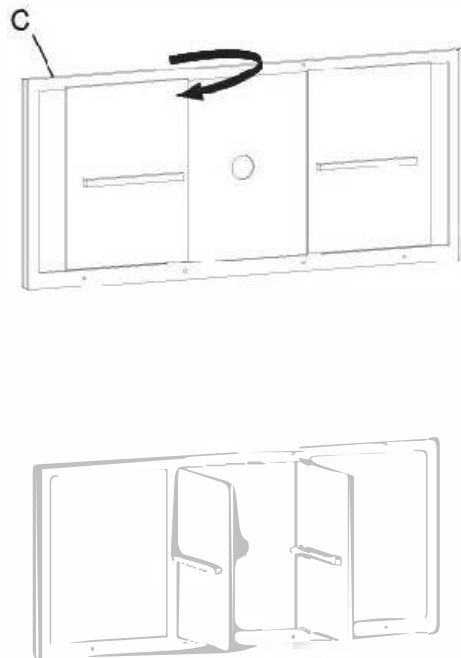

STEP - 03

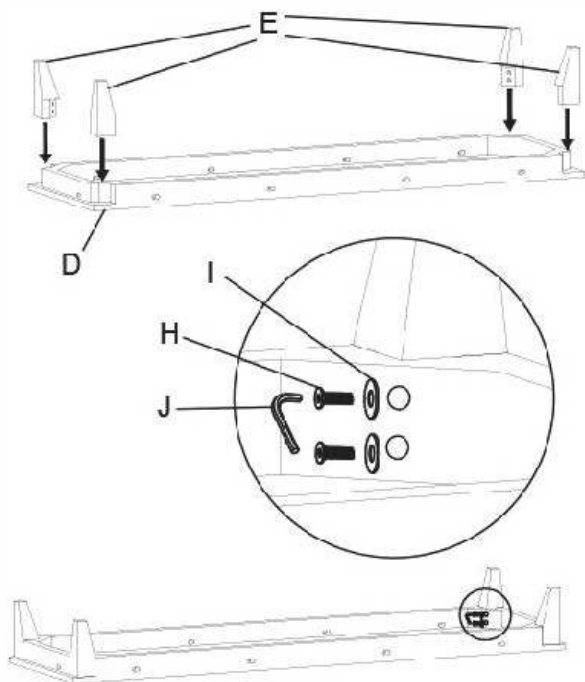

STEP - 04

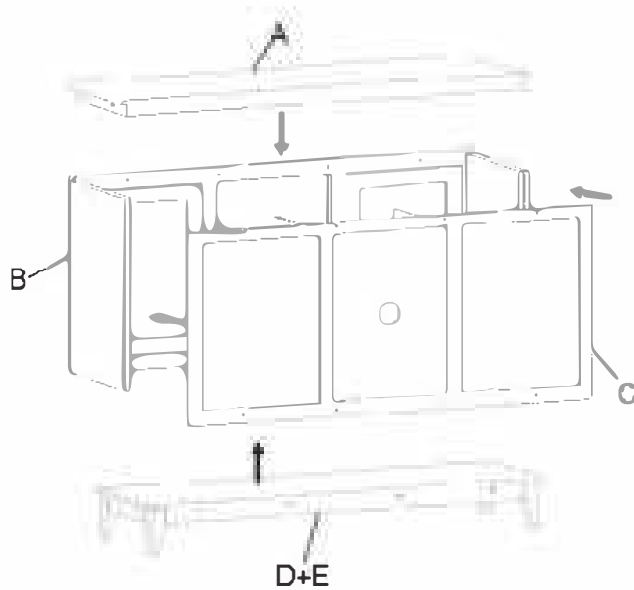

STEP - 05

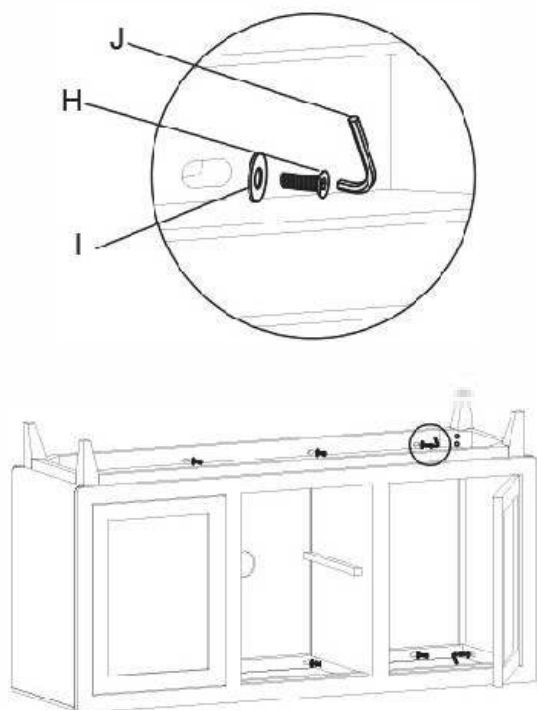

STEP - 06

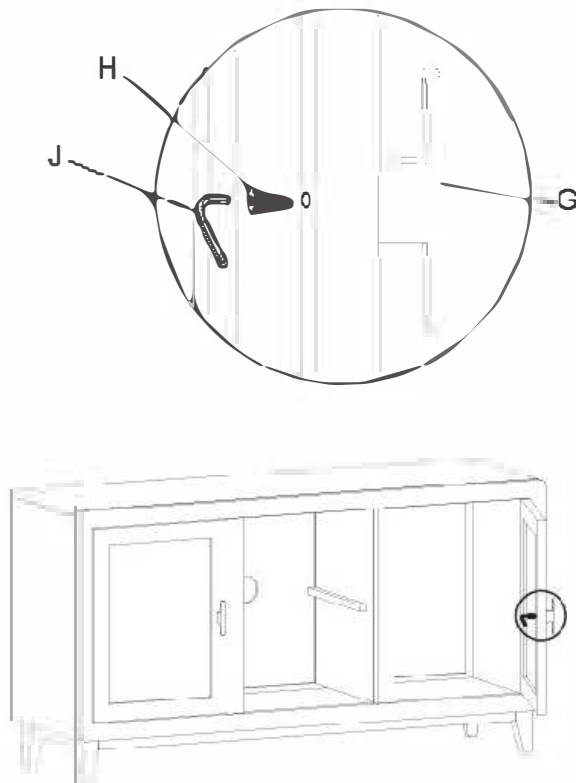

STEP - 07

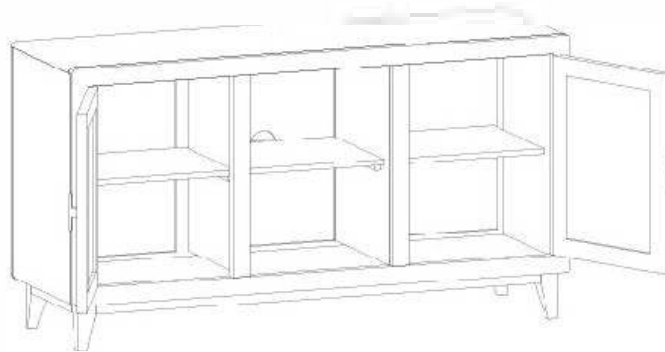
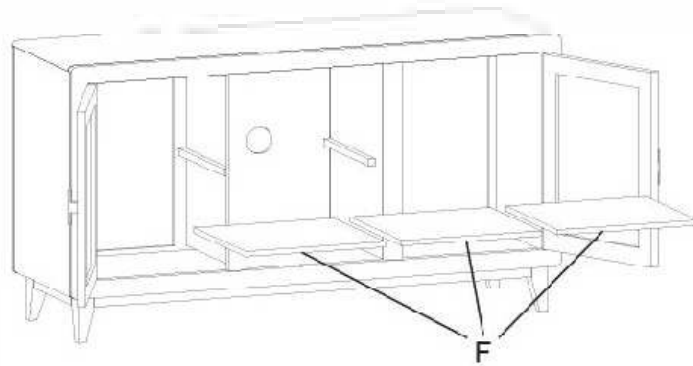

FINAL STEP

