











Read this instruction carefully. See hardware and furniture part list for guidance. Be sure all parts are complete, before you assemble. Place all wooden furniture parts on a clean and flat soft surface to prevent from being scratched. Follow the figure to start assembling.

- CAUTION :**
1. Do not FULLY - TIGHTEN the nuts or nuts bolts until they are ready for assembly.
 2. Do not OVER - TIGHTEN the nuts or bolts to avoid causing damages to the thread.
 3. Keep all hardware parts out of reach of children.

NOTE : THE LIST AND QUANTITY SHOWN ARE FOR 1 UNIT ASSEMBLY.
Tools needed : Screwdriver (not provided).

PART LIST		
ITEM	DESCRIPTION	QTY
A	HEADBOARD	1 PC
B	HEADBOARD LEG	2 PCS
C	HEADBOARD PANEL	1 PC
D	FOOTBOARD	1 PC
E	SIDE RAIL (L)	2 PCS
F	SIDE RAIL (R)	2 PCS
G	METAL CENTER RAIL	1 PC
H	METAL CENTER SUPPORT LEG	1 PC
I	METAL CENTER SUPPORT	1 PC
J	BED SLAT	2 SET

HARDWARE LIST		
ITEM	DESCRIPTION	QTY
1	JCBB BOLT M8 x 16mm 	18 +1 PCS
2	JCBB BOLT M8 x 35mm 	16 +1 PCS
3	JCBB BOLT M8 x 50mm 	1 PCS
4	M8 SPRING WASHER 	16 +1 PCS
5	M8 FLAT WASHER 	16 +1 PCS
6	WOOD SCREW M4 x 38mm 	8 PCS
7	M5 ALLEN KEY (BALL SHAPE) 	1 PC
EXTRA HARDWARE		
E1	JCBB BOLT M8 x 16mm 	1 PC
E2	JCBB BOLT M8 x 35mm 	1 PC
E3	M8 SPRING WASHER 	1 PC
E4	M8 FLAT WASHER 	1 PC

IMPORTANT, RETAIN FOR FUTURE REFERENCE: READ CAREFULLY

STEP 1

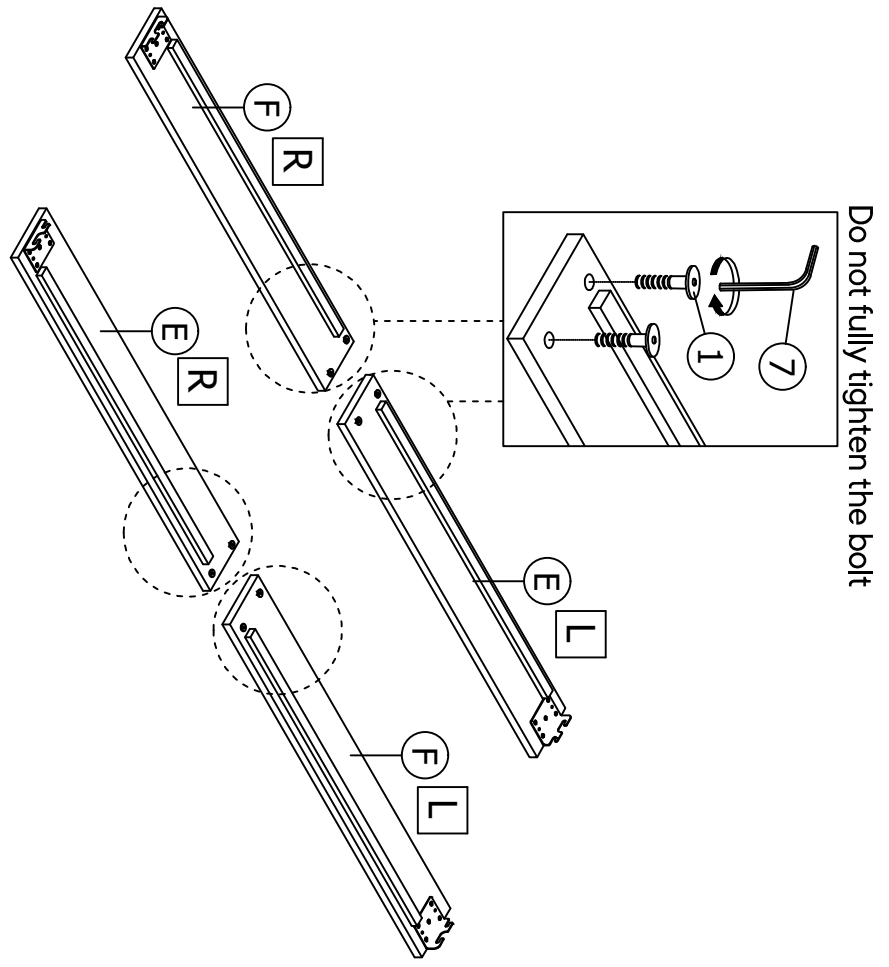
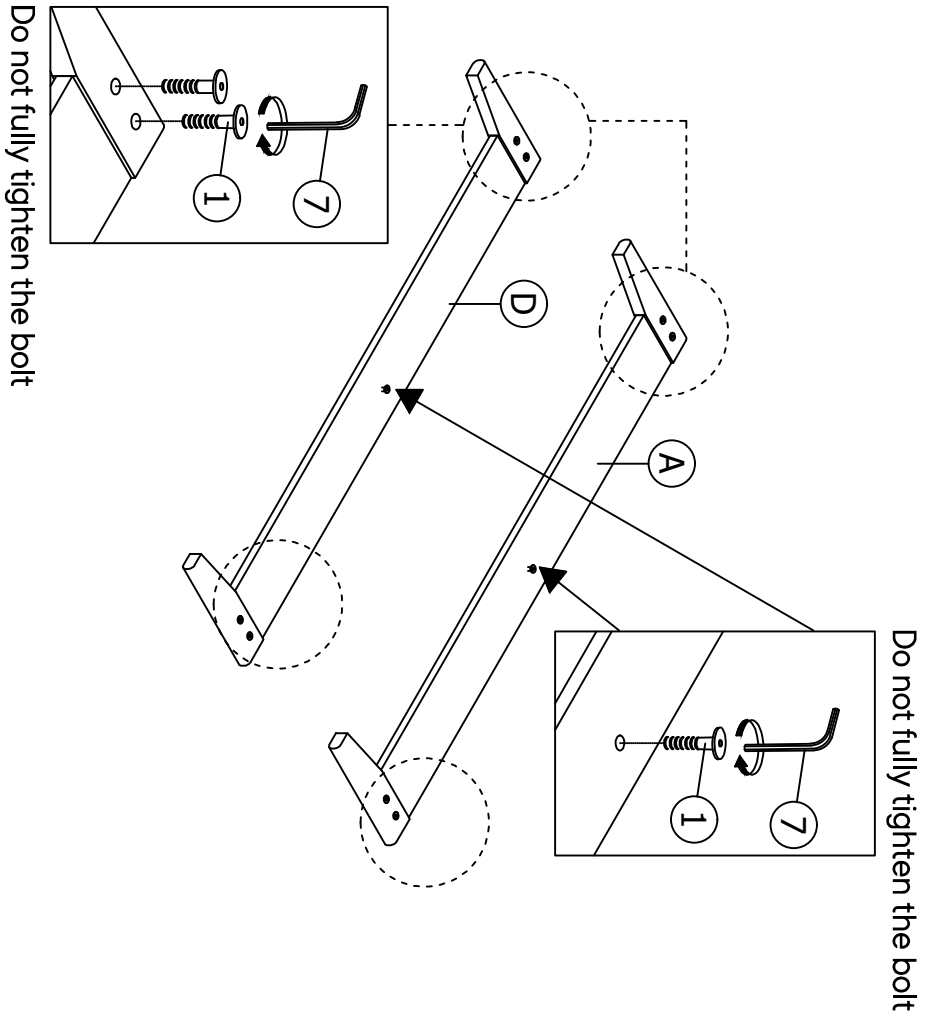

STEP 2

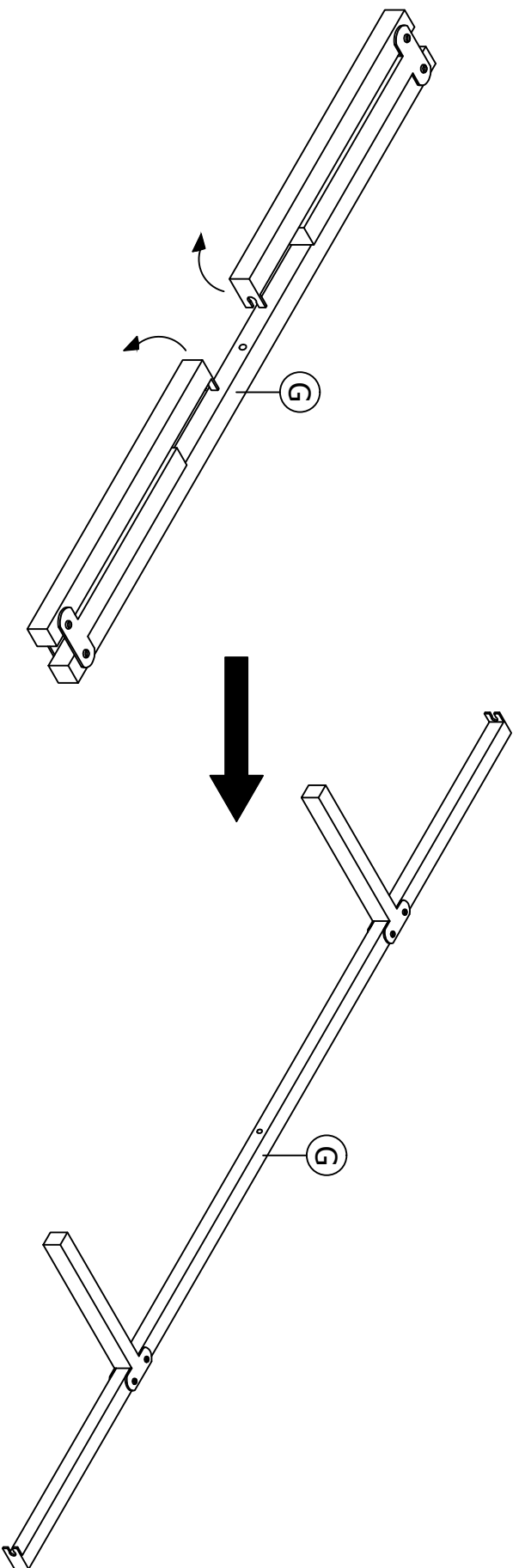

STEP 3

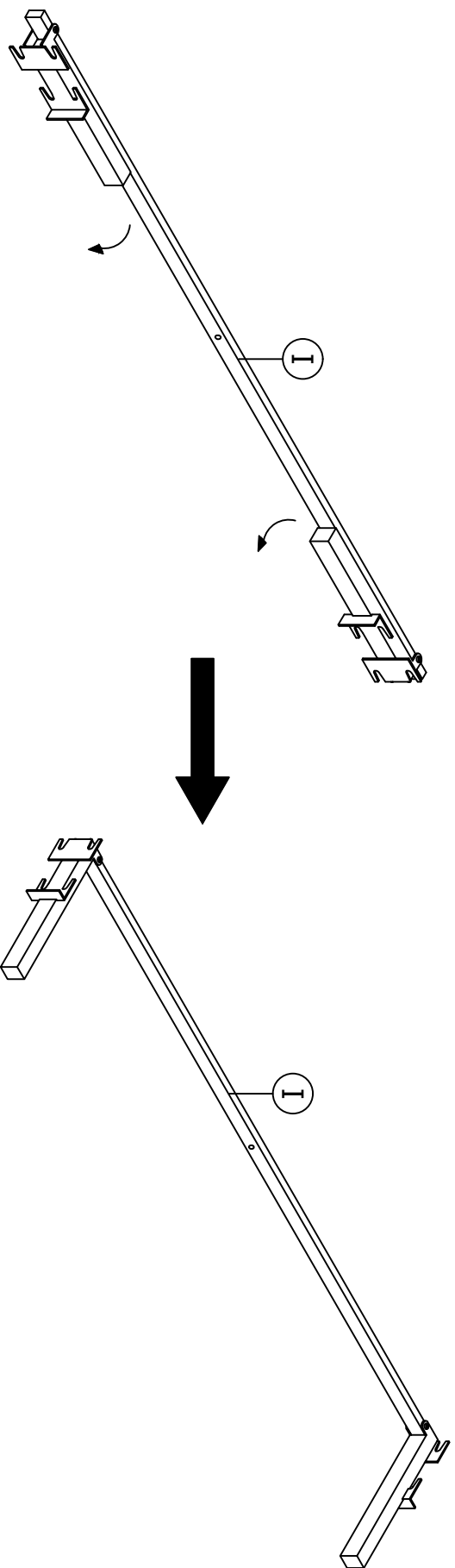

STEP 4

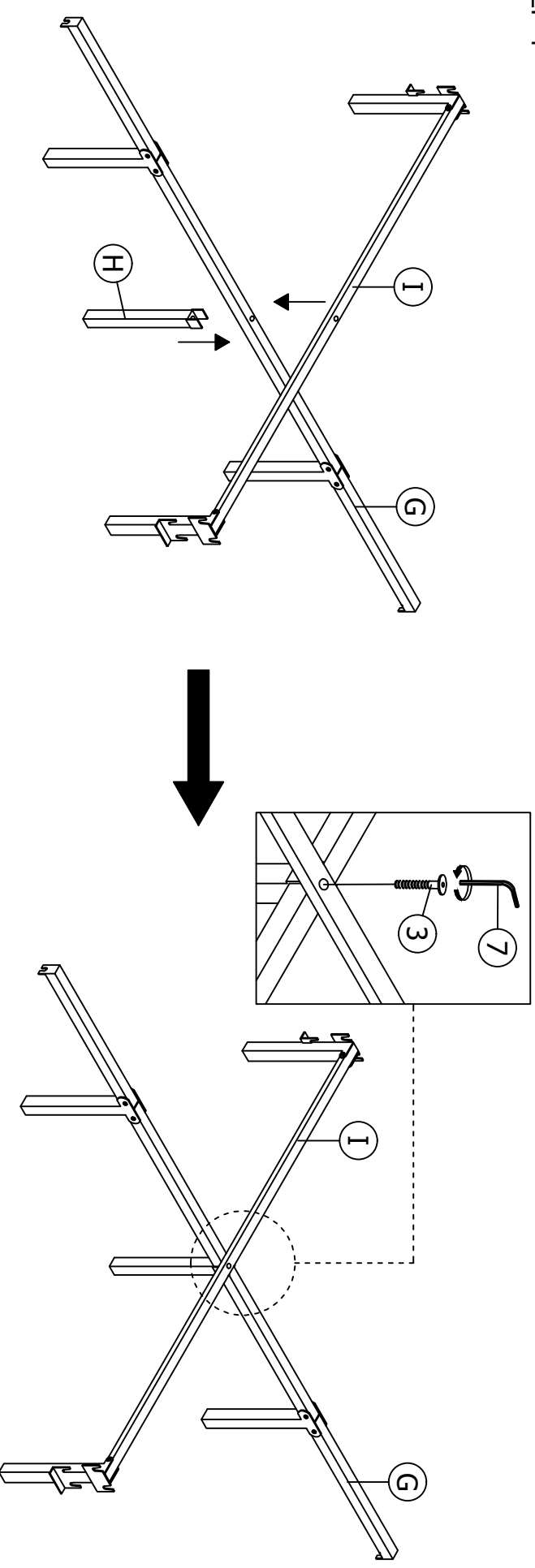

STEP 5

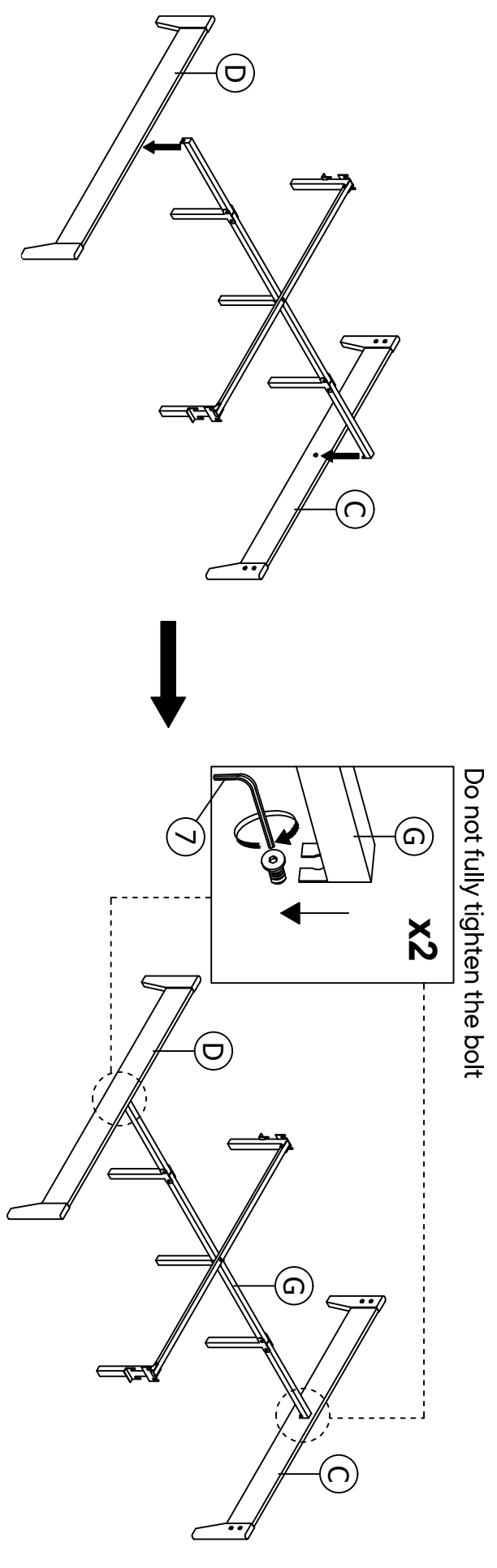

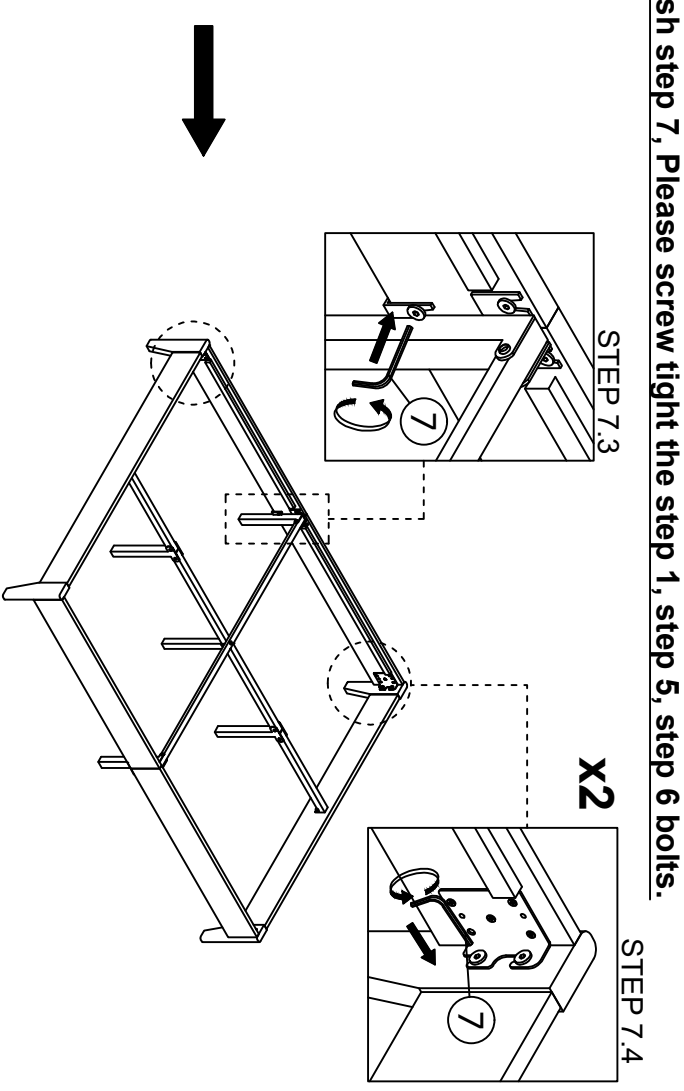
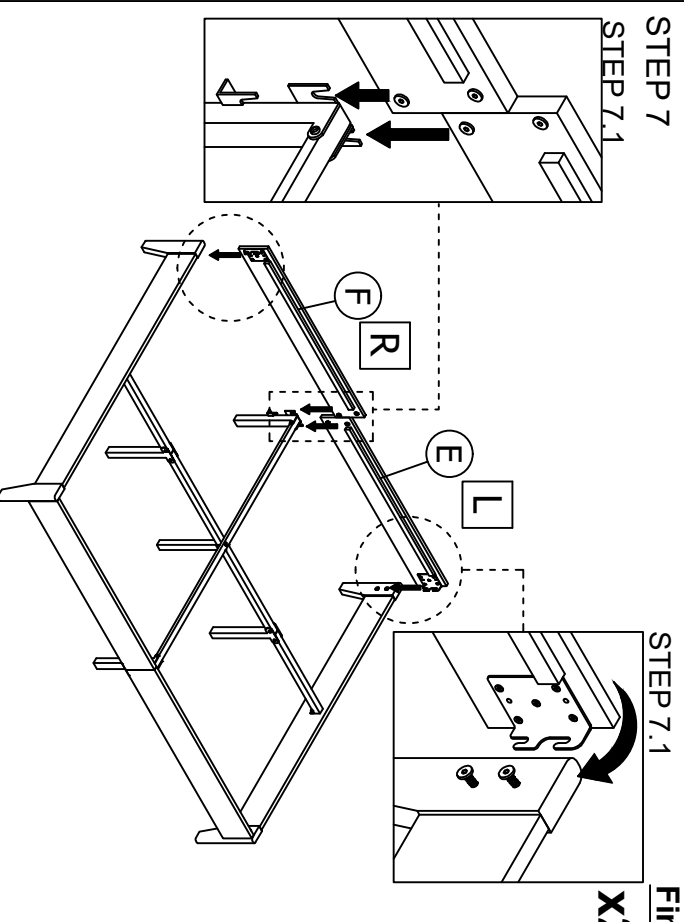
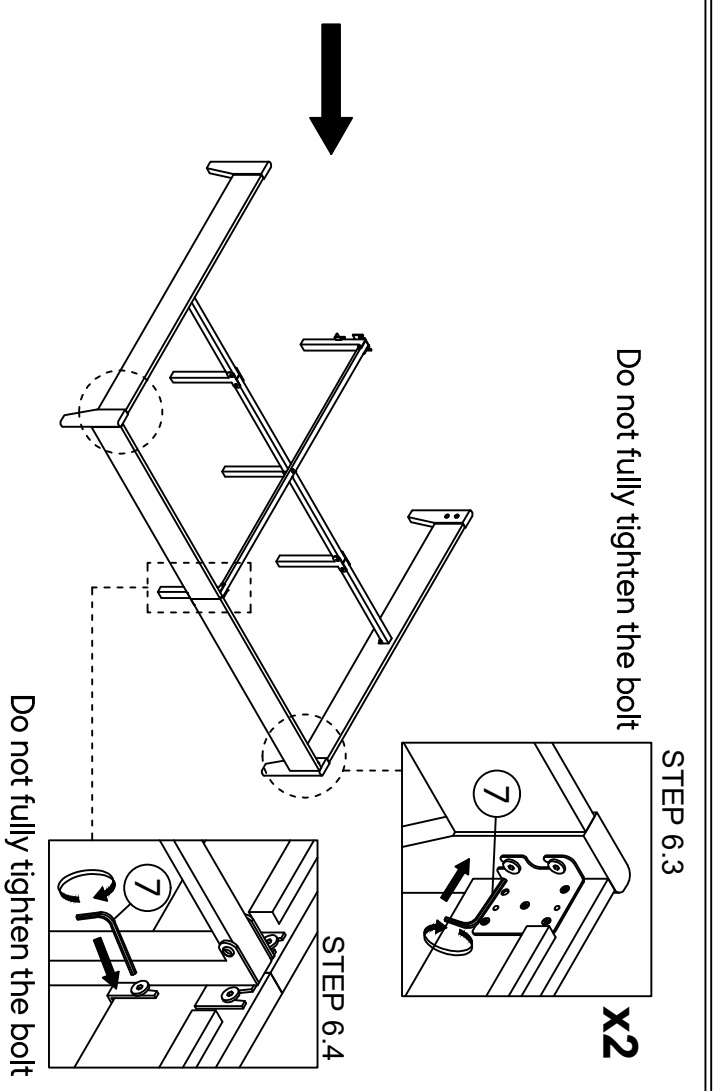
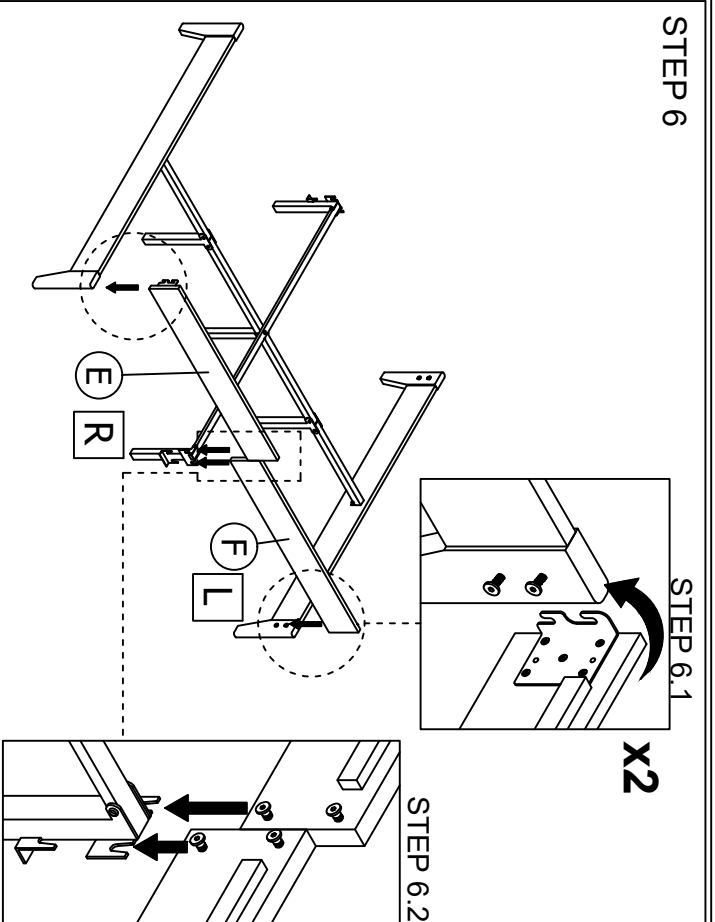

STEP 8

NOTE : Assemble headboard holes according to your desired headboard size height.

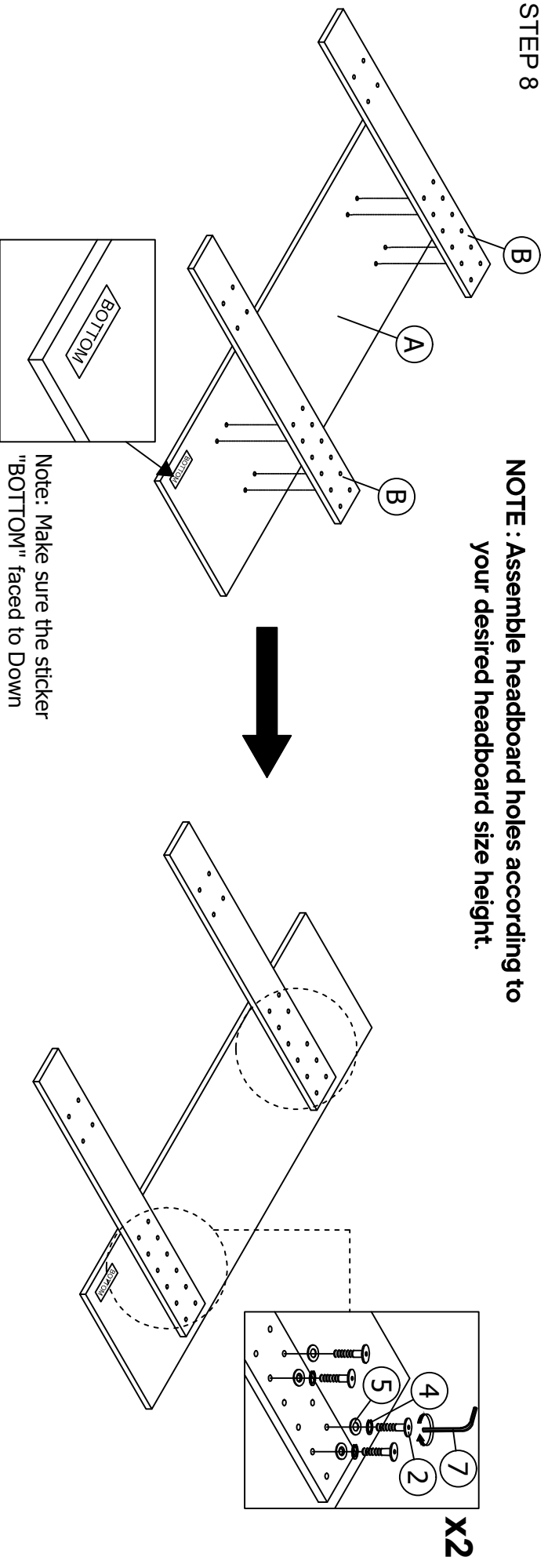

STEP 9

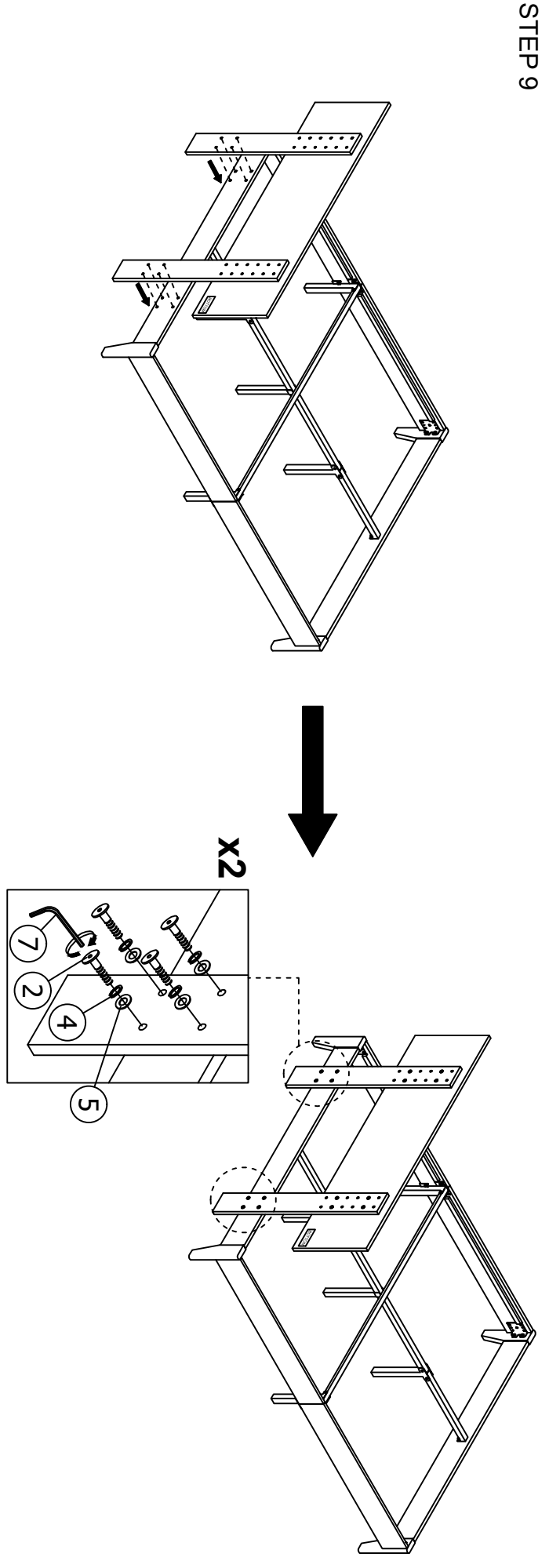

STEP 10

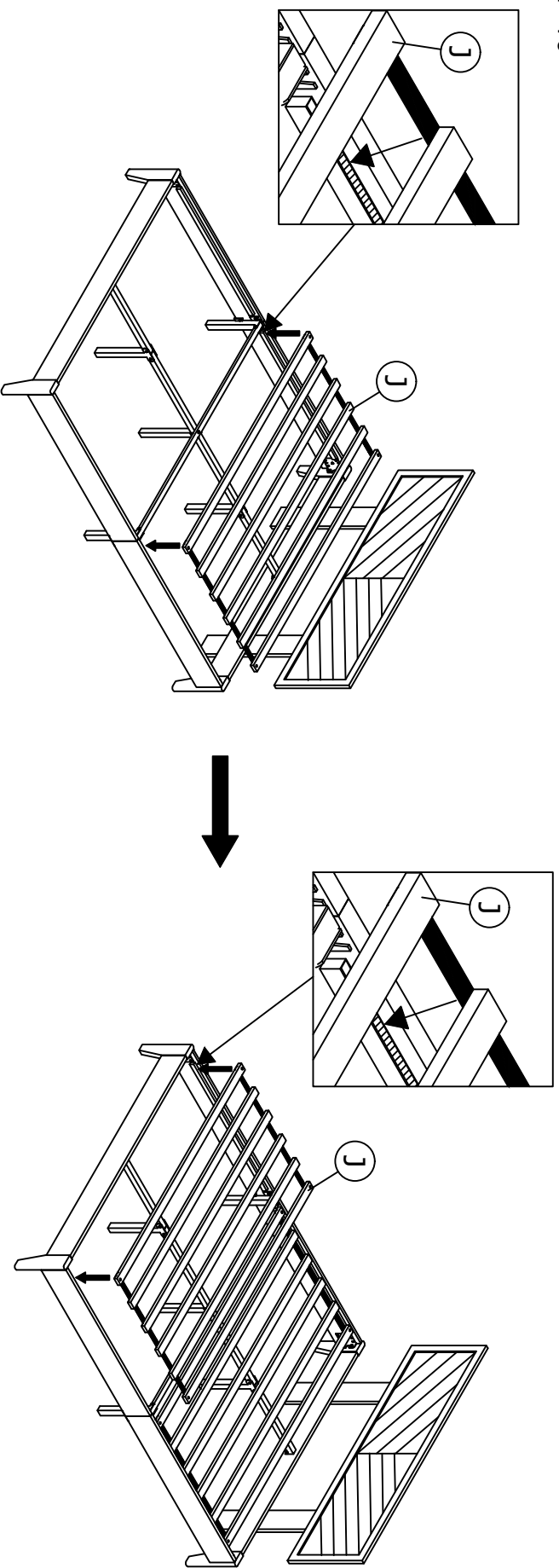

STEP 11

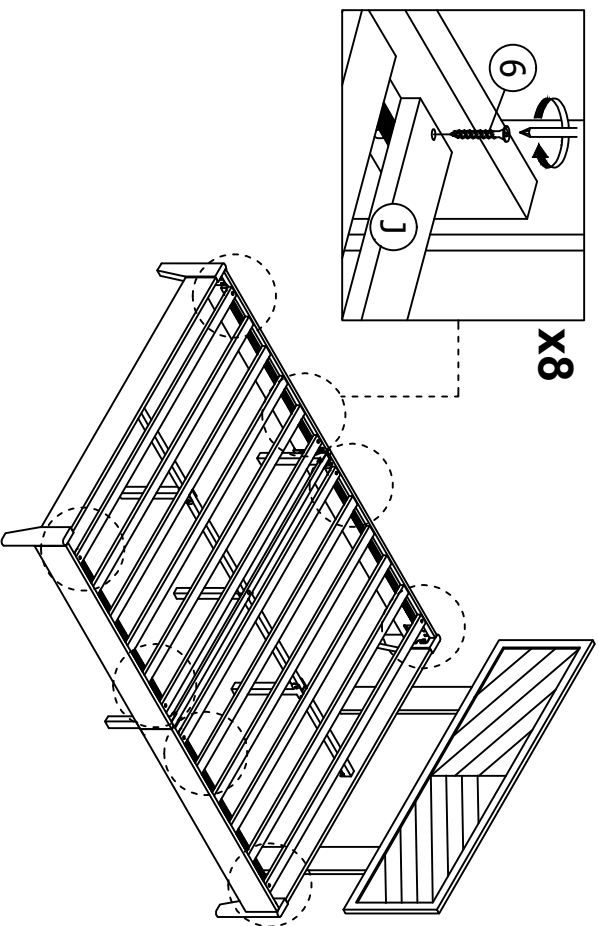

STEP 12

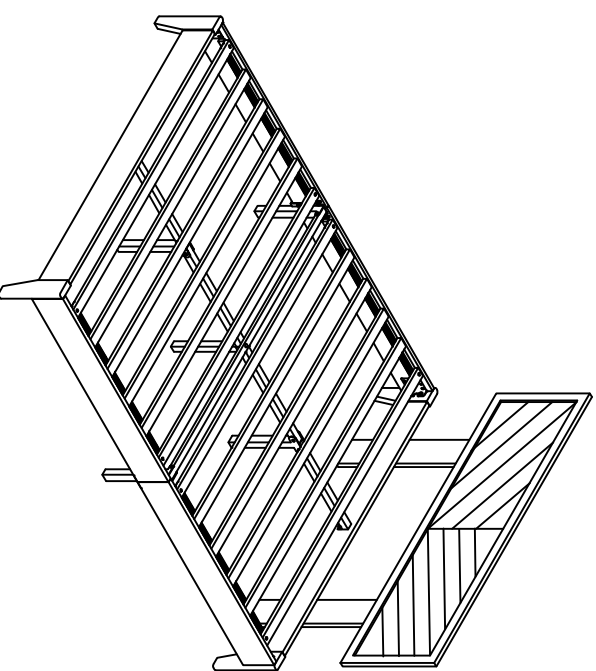

* When moving the position, the center support legs must be adjusted or straightened to avoid any broken problems.