

INSTRUCTION MANUAL

Rocking Egg Chair

TBDLY2

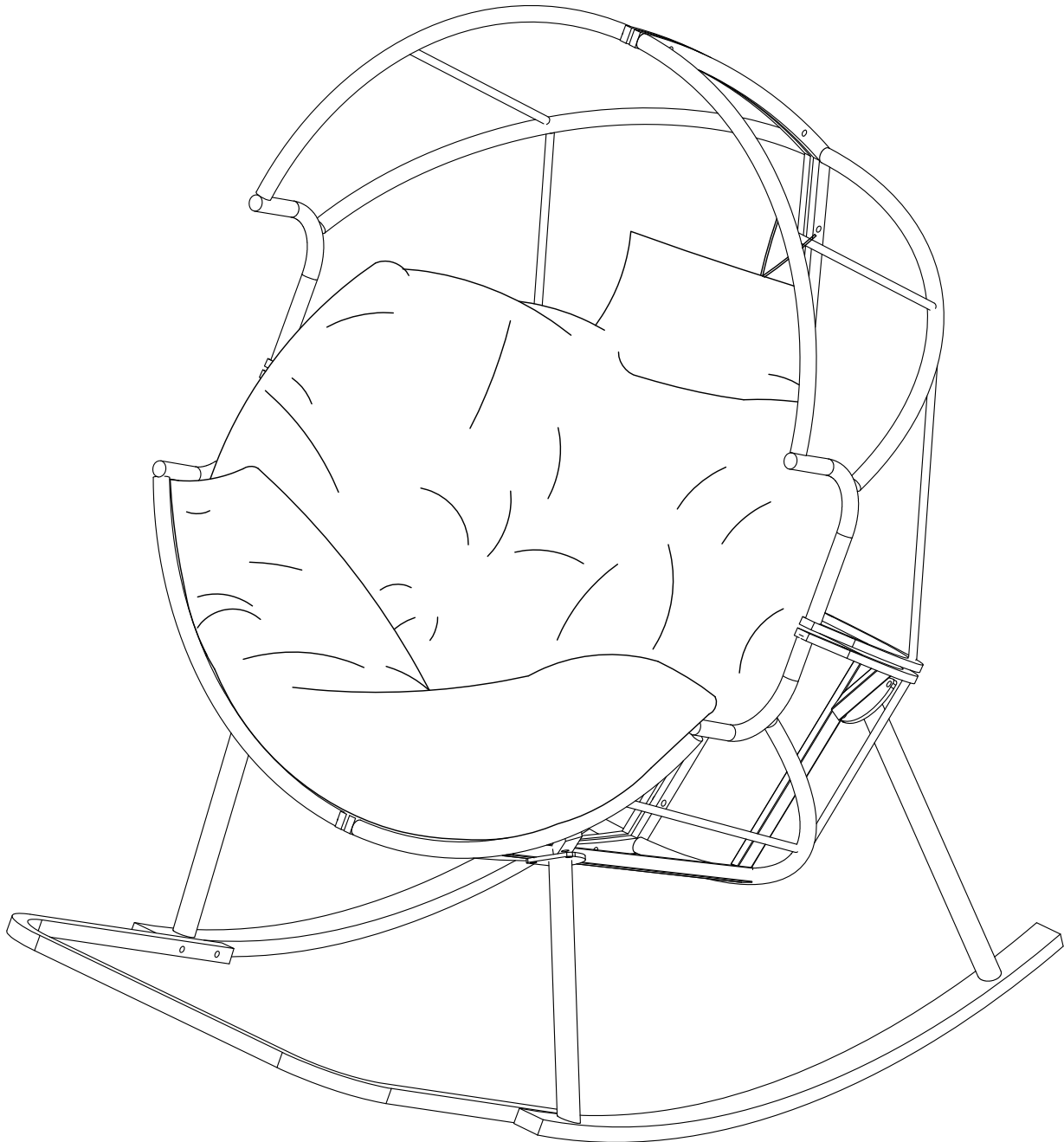

Thank you for shopping with us!

If any parts is missing, broken upon receipt or you need any help from us. For the FASTEST solutions, please FIRSTLY CONTACT US at our after-sales email: **CSsince1987@hotmail.com!**

IMPORTANT

Please follow the instruction manuals and use a pad to avoid damage during assembly.

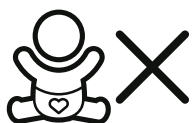

Not intended for use by children. Please keep your children closely supervised.



Keep away from fire or other heat sources.



Do not use harsh cleaner for cleaning!

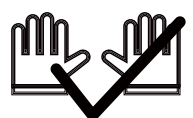

We recommend wearing protective gloves for assembly.



Identify, sort and count the parts before assembly.

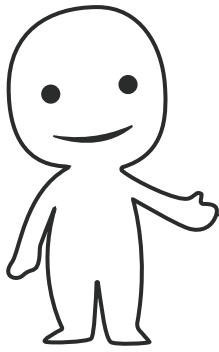

Please prepare the following tools



When installing, please carefully confirm whether each screw corresponds to the manual, accessories with similar shapes can be distinguished by size

Parts List

(A) LEFT 1PC	(B) RIGHT 1PC	(C) LEFT 1PC	(D) RIGHT 1PC
(E) LEFT FRONT LEG 1PC	(F) RIGHT FRONT LEG 1PC	(G) LEFT BACK LEG 1PC	(H) RIGHT BACK LEG 1PC
(J) LEFT ROCKING LEG 1PC	(K) RIGHT ROCKING LEG 1PC	(L) SUPPORT BAR 1PC	(M) BACK CUSHION 1PC
(N) SEAT CUSHION 1PC			

Hardware List

① x 12

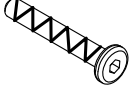

M6 x 45 mm

② x 12



M6 x 20 mm

③ x 44



Washer

④ x 12



Nut

⑤ x 8

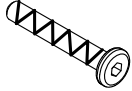

M6 x 35 mm

⑥ x 4



Plastic Washer

⑦ x 1



Wrench



⑧ x 1

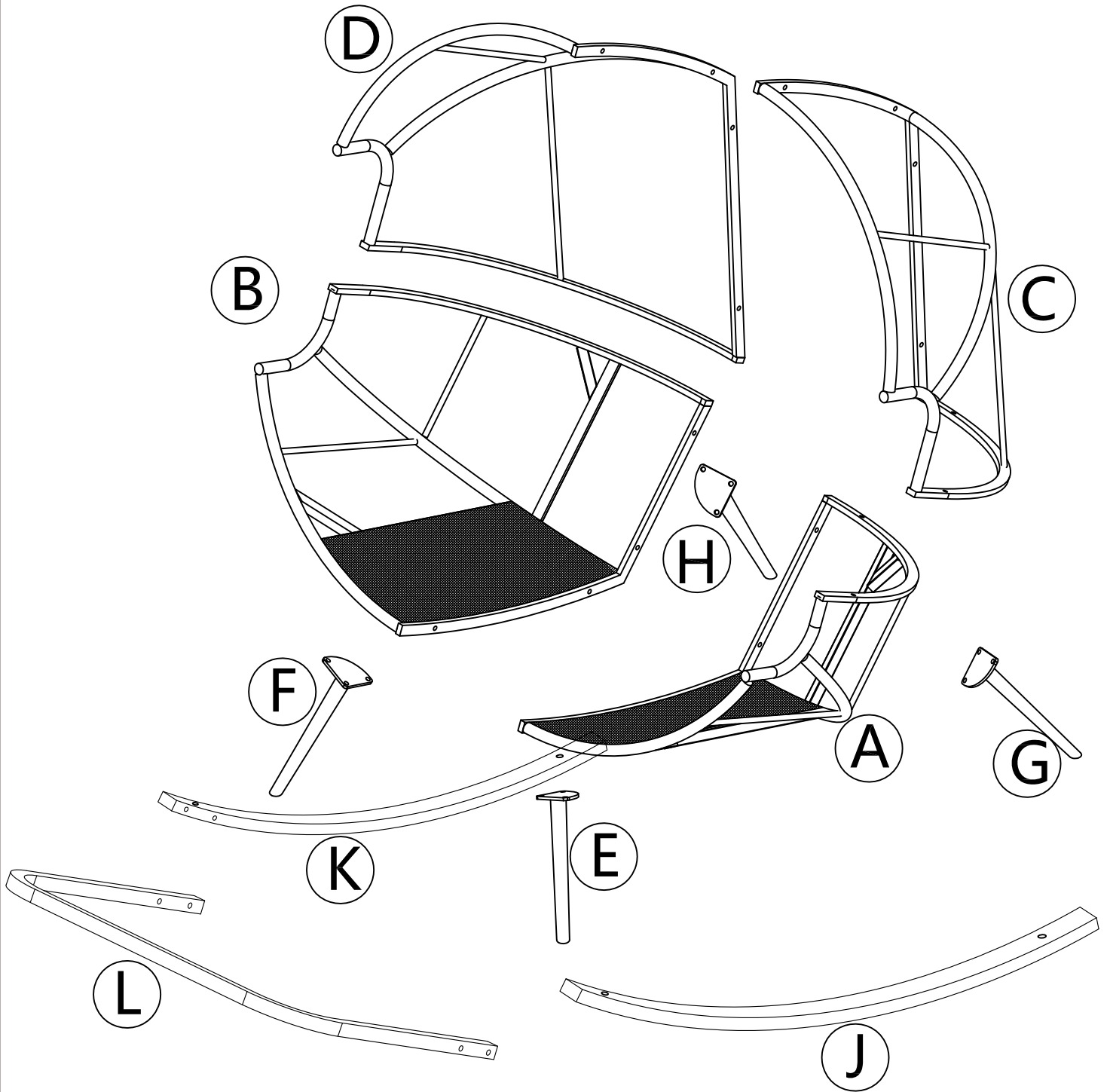

EXPLODED VIEW

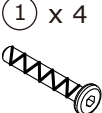

STEP 1

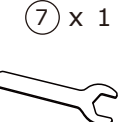
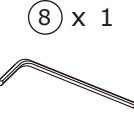
 M6 x 45 mm					
---	---	---	---	--	--

Fix part A with part B with four M6x45mm Screws (1) and Flat Washers (3) and nut (4). Use Allen key (8) and Wrench (7).
DO NOT FULLY TIGHTEN.

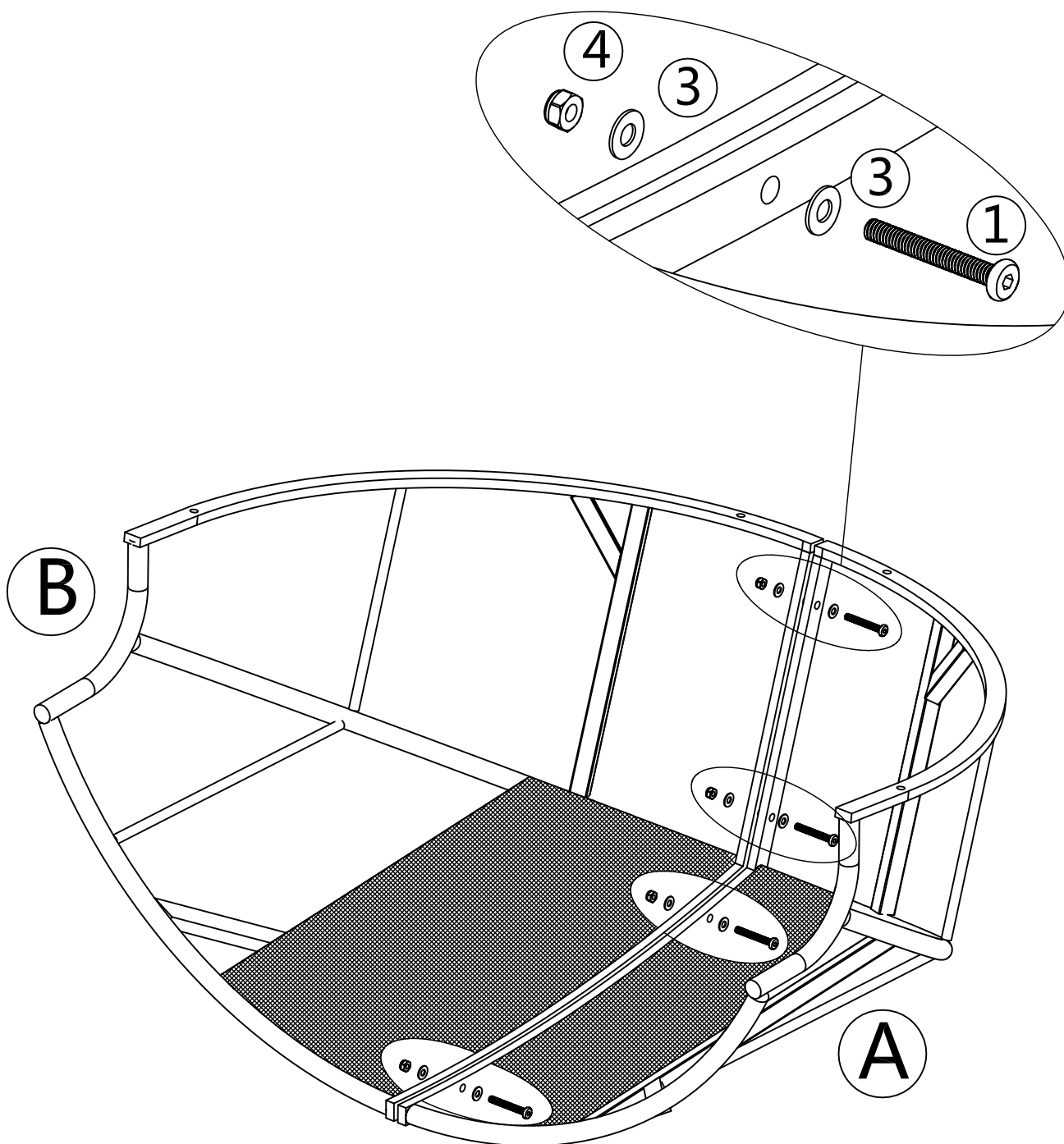



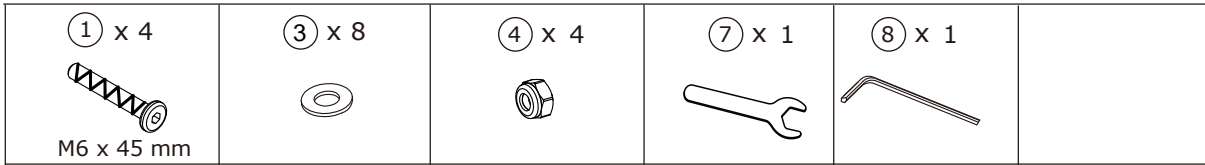

STEP 2

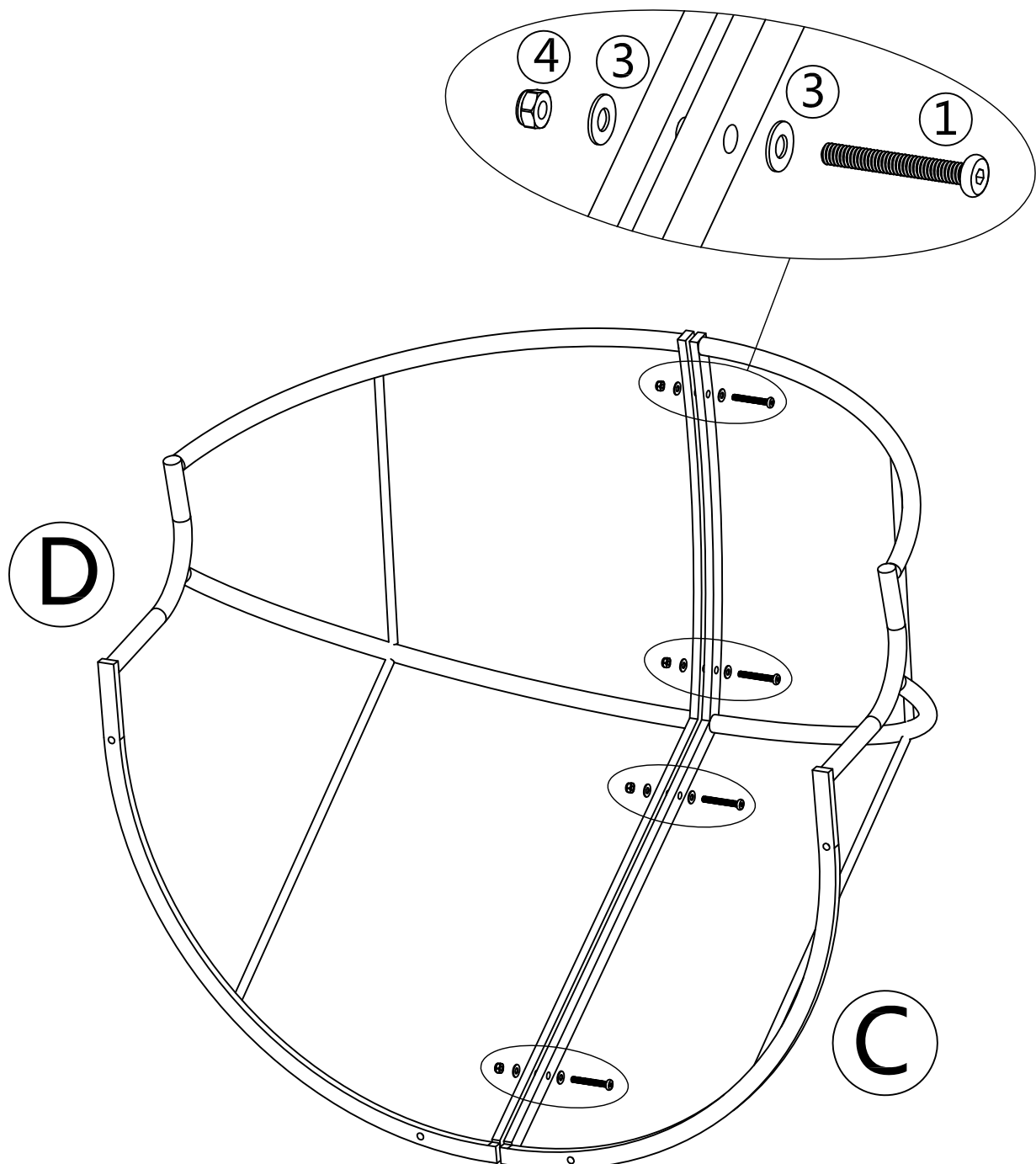

Fix part C with part D with four M6x45mm Screws (1) and Flat Washers (3) and nut (4). Use Allen key (8) and Wrench (7). **DO NOT FULLY TIGHTEN.**

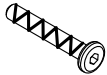

STEP 3



① x 4  M6 x 45 mm	③ x 8 	④ x 4 	⑦ x 1 	⑧ x 1 	
--	--	--	--	---	--

Fix part A with part C and part B with part D with four M6x45mm Screws (1) and Flat Washers (3) and nut (4). Use Allen key (8) and Wrench (7).

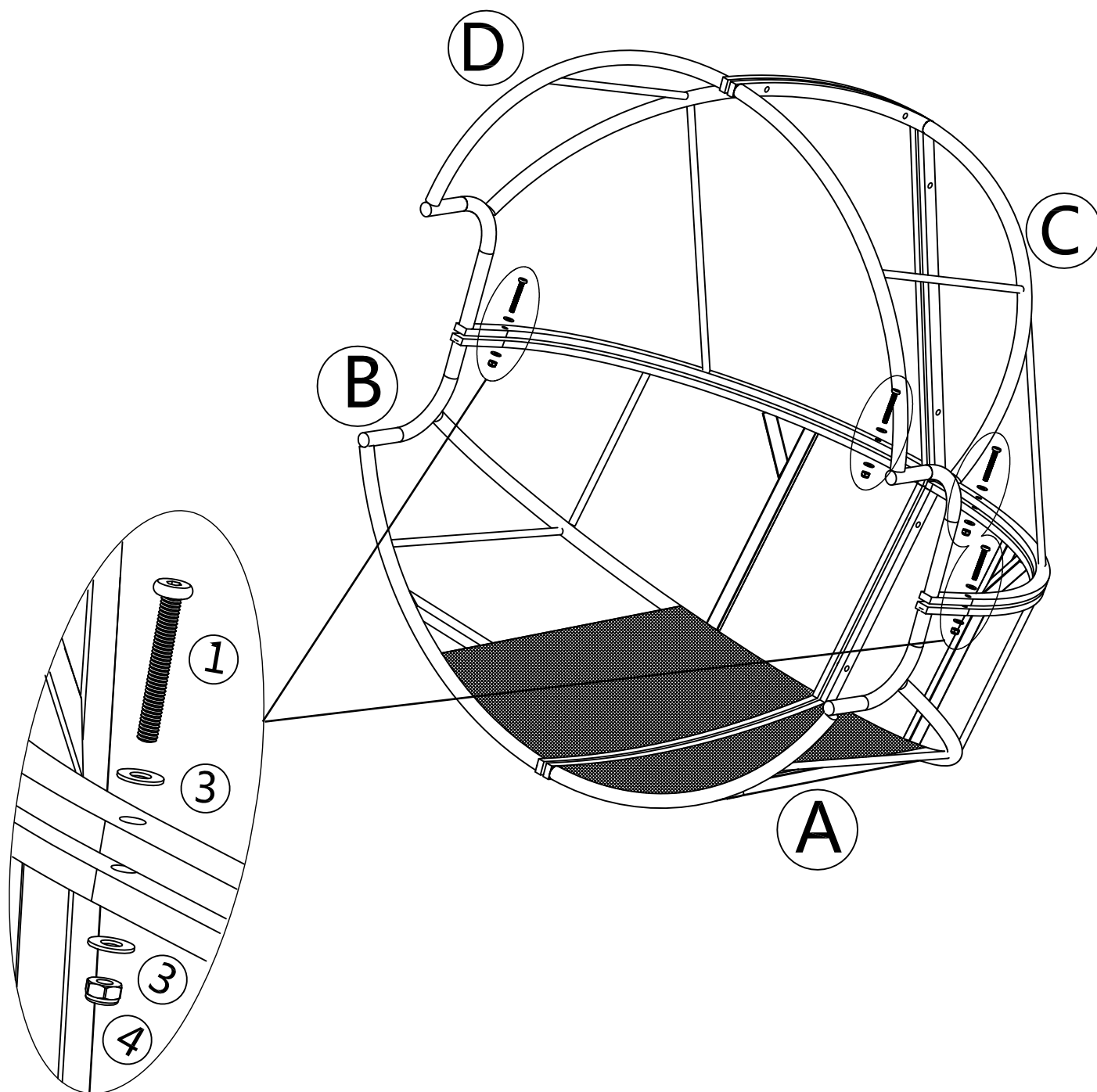
DO NOT FULLY TIGHTEN.



STEP 4

② x 6  M6 x 20 mm	③ x 6 	⑧ x 1 	
--	--	--	--

Fix part E and part F with part A and part B with six M6x20mm Screws (2) and Flat Washers (3). Use Allen key (8).

DO NOT FULLY TIGHTEN.

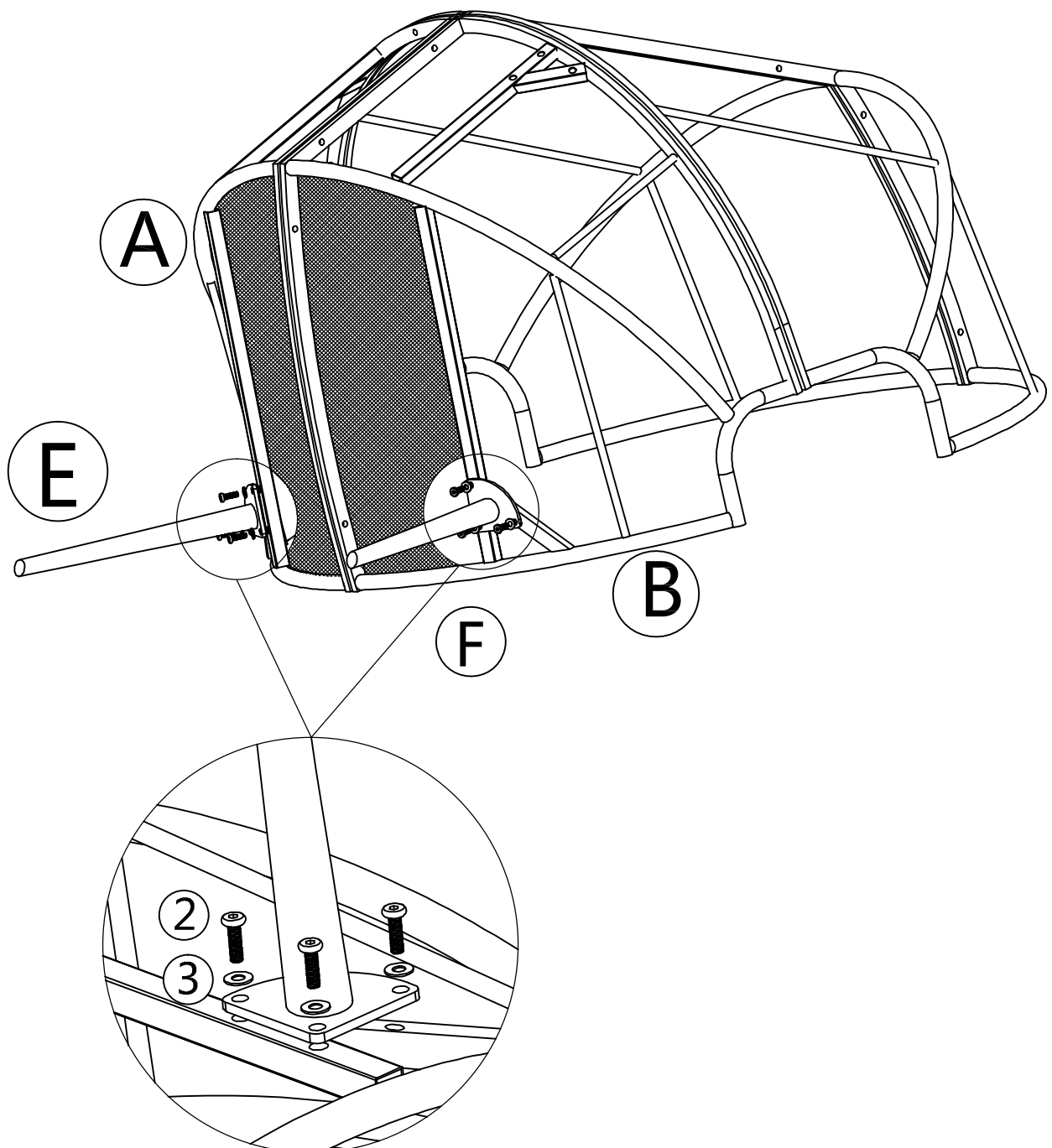

STEP 5

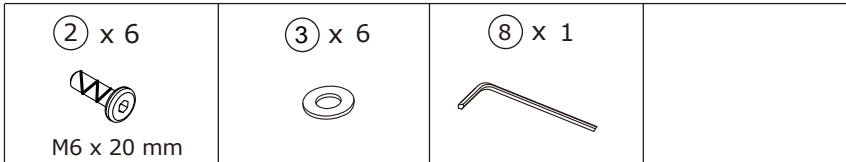

Fix part G and part H with part A and part B with six M6x20mm Screws (2) and Flat Washers (3). Use Allen key (8).

DO NOT FULLY TIGHTEN.

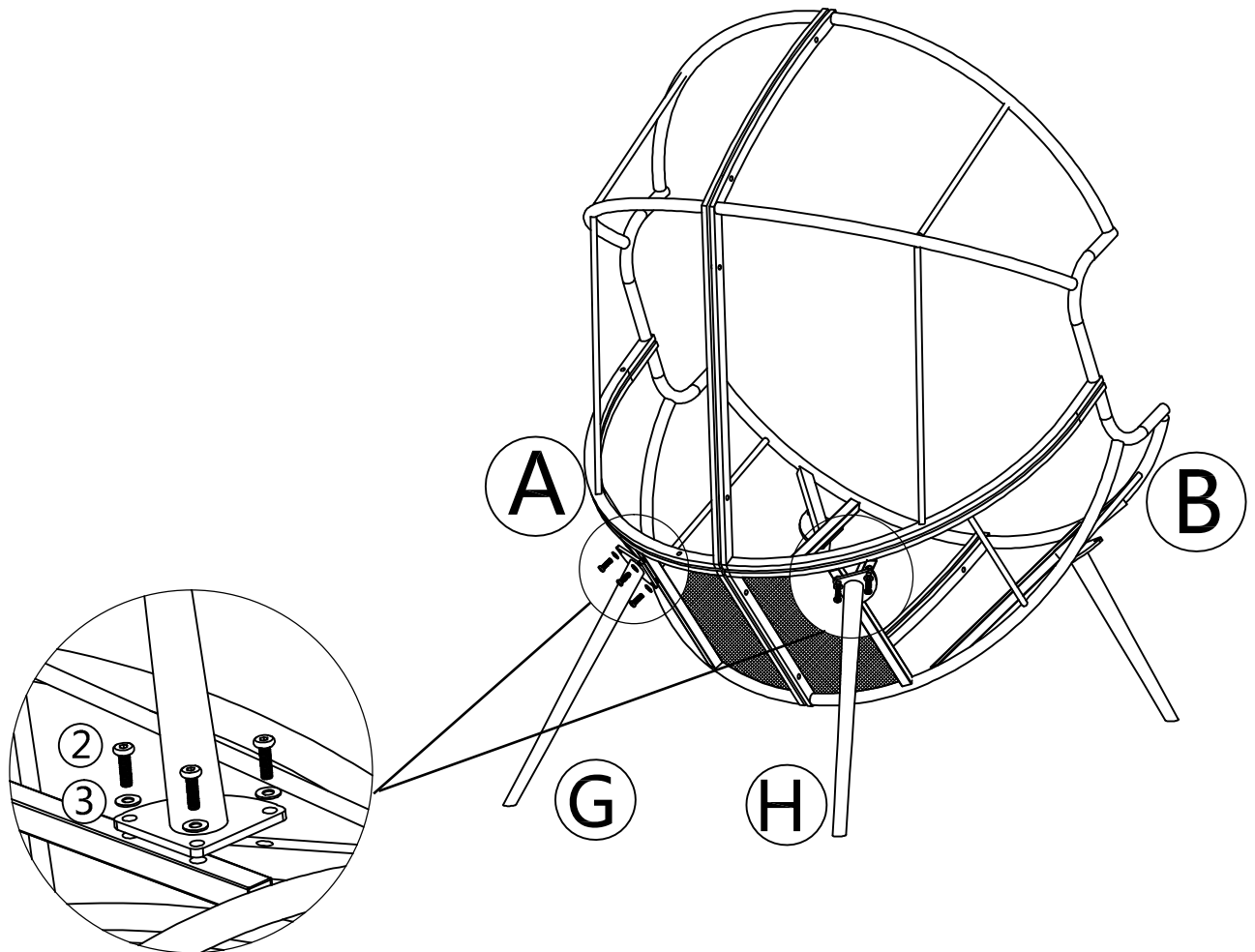

STEP 6

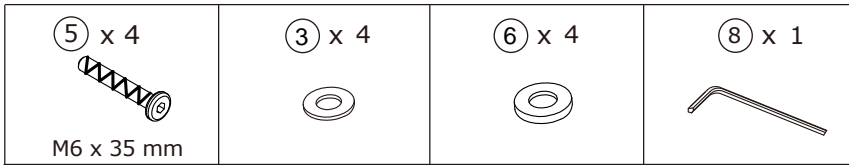

Fix part J and part K with the four legs with four M6x35mm Screws (5) and Flat Washers (3). Use Allen key (8).

DO NOT FULLY TIGHTEN.

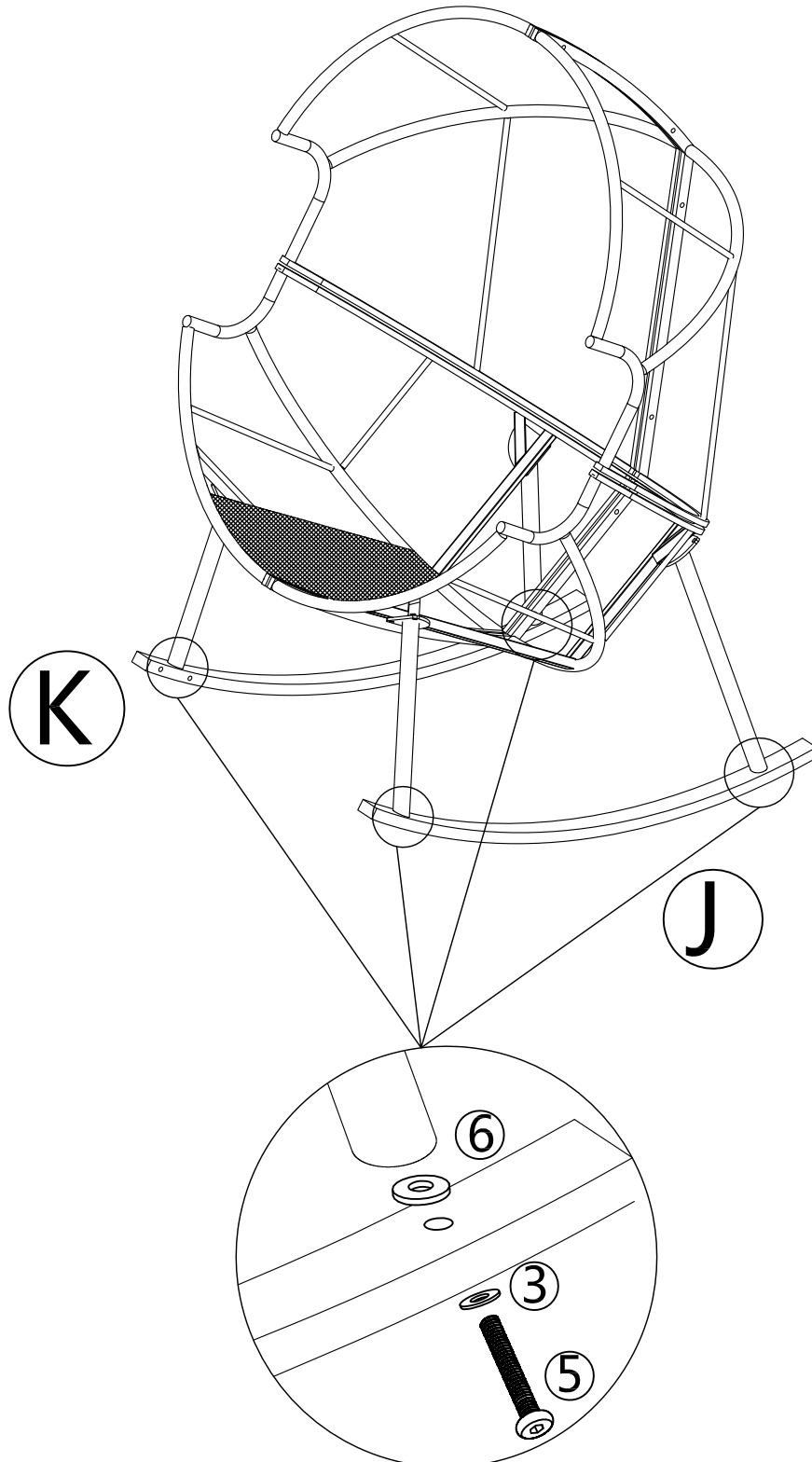

STEP 7

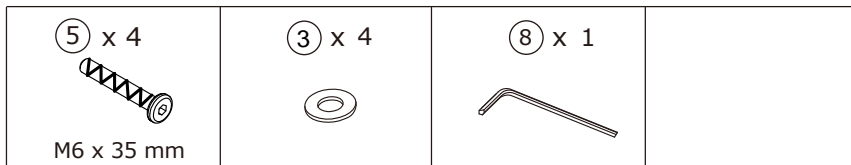

Fix part L with part J and part K with four M6x35mm Screws (5) and Flat Washers (3). Use Allen key (8).

DO NOT FULLY TIGHTEN.

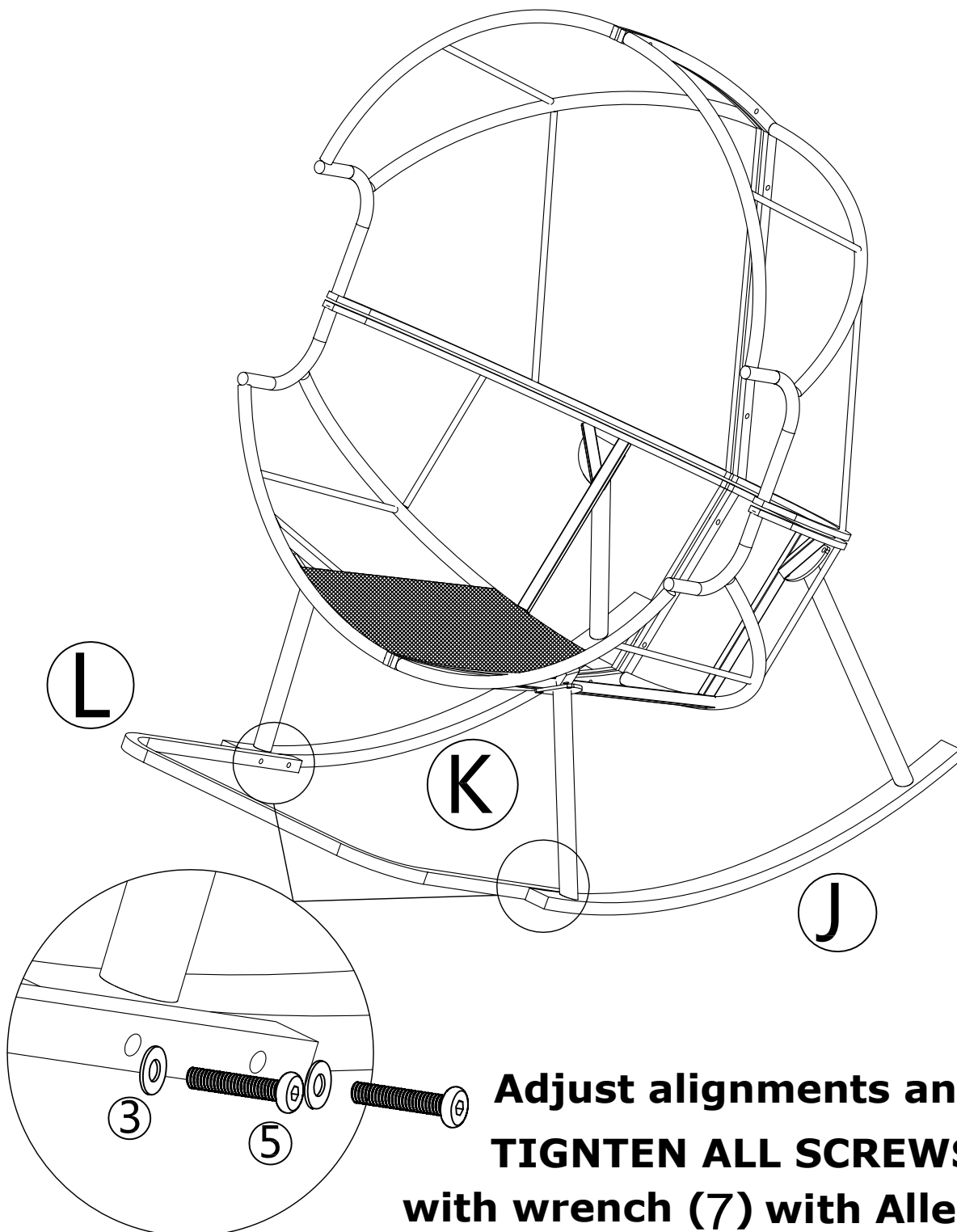

STEP 8

Tie the back cushion and the seat cushion together and put it in the chair.

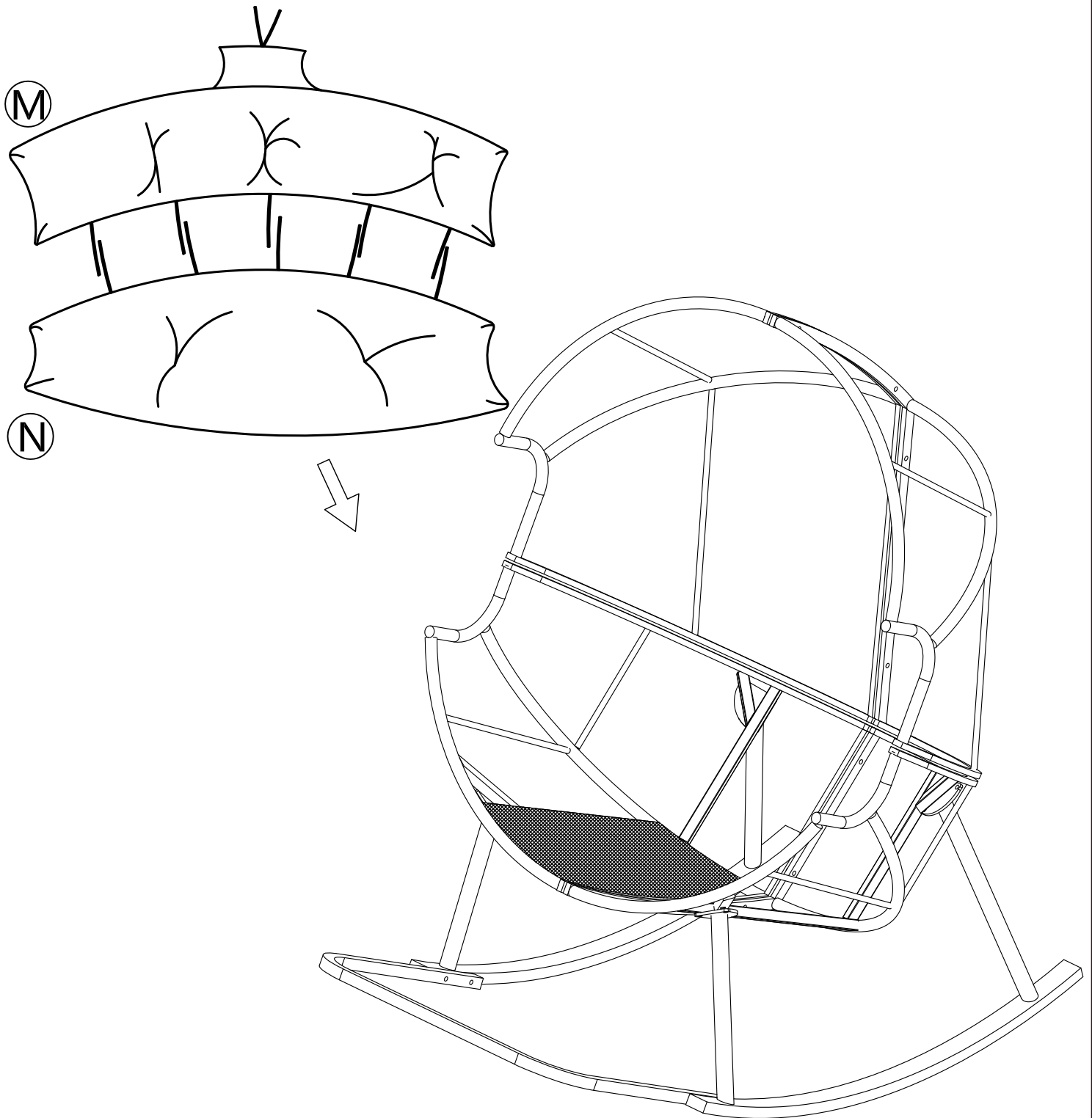

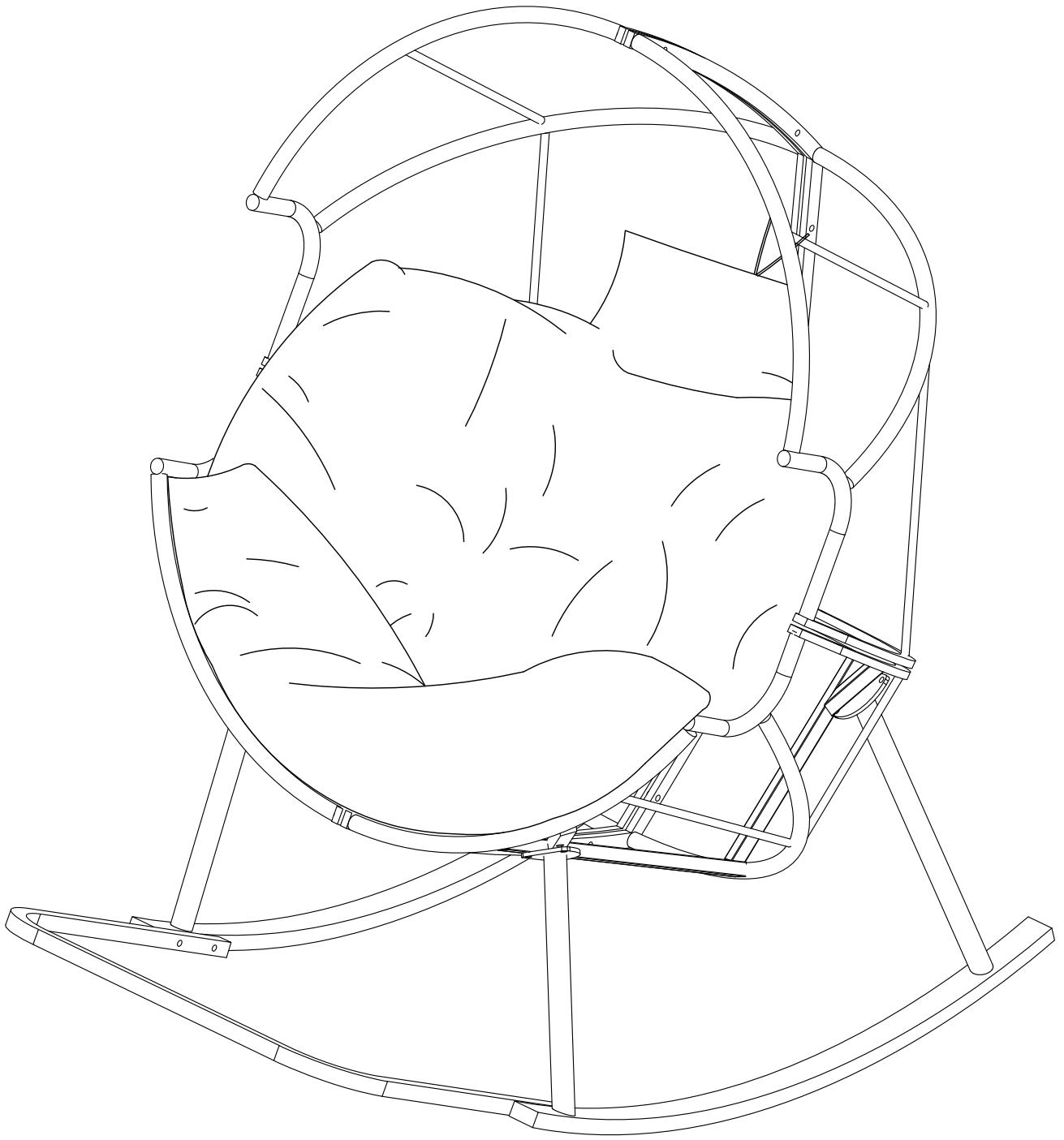

Assembly Finished

Warning

Seller is responsible for the product-related issues occurred upon receipt, but will not be responsible for the personal injury, property damage or loss resulting from the incorrect assembly, improper use, inadequate maintenance or neglect of this product.