

Assembly Instructions

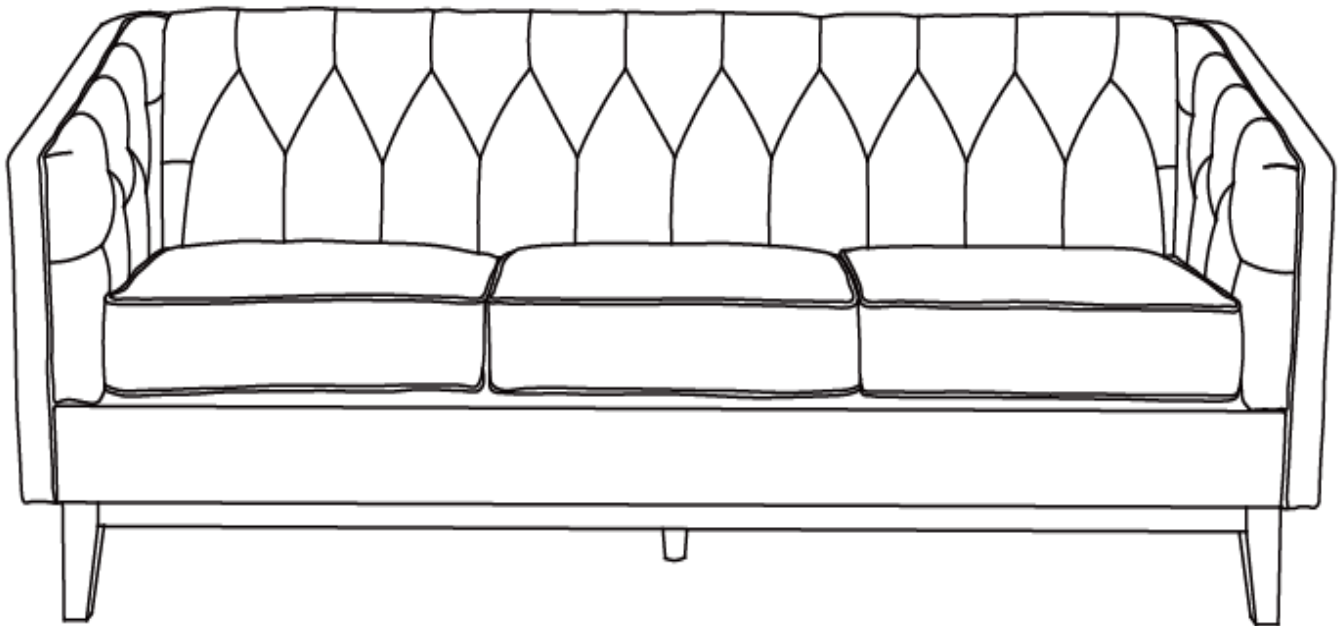

Caution: You must read this before you proceed

Sofa



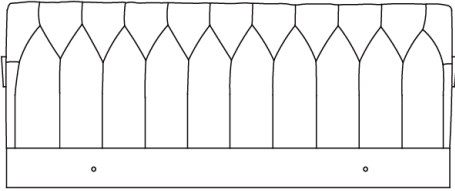
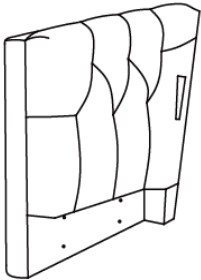
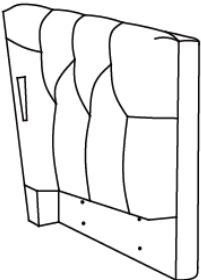
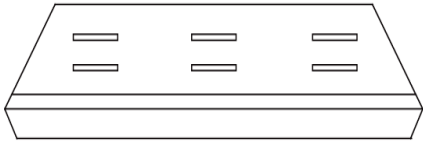
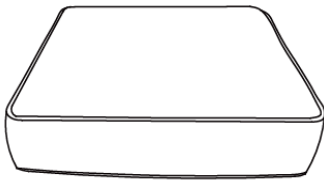

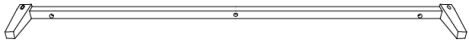
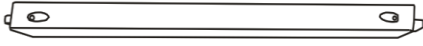





Part List

Label	Picture	Description	QTY
A		Backrest	1
B		Left Armrest	1
C		Right Armrest	1
D		Seat	1
E		Seat Cushion	3

F		Underframe Piece	2
G		Rail	2
H		Middle Support Leg	1

Hardware

Label	Picture	Description	QTY
①		Bolt (M8*70 MM)	11
②		Ø30 Washer(M8)	11
③		Gasket	2
④		Allen Wrench (M8)	1
⑤		Spring Washer(M8)	17
⑥		Bolt (M8*50MM)	7

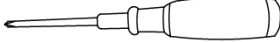
⑦		Ø16 Washer(M8)	7
⑧		Screw (M4*50MM)	9
⑨		Screwdriver	1

Assembly Preparation

Before Beginning Assembly:

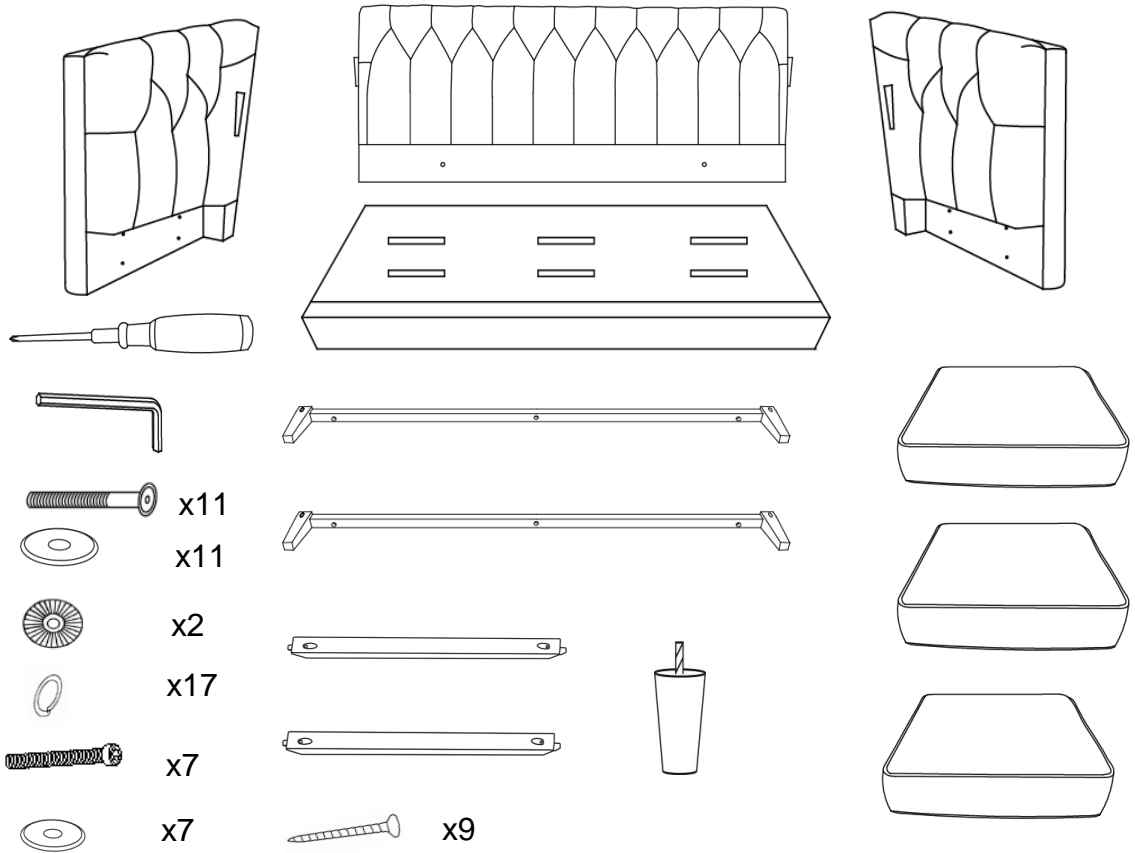

- Read instructions, cover to cover-



- Have 2 adults on hand for assembly-



- Do not assemble on flooring or carpet-



- Assemble on a clean non-marring surface (packing foam)-



- Save all packaging until finished-

Assembly Steps

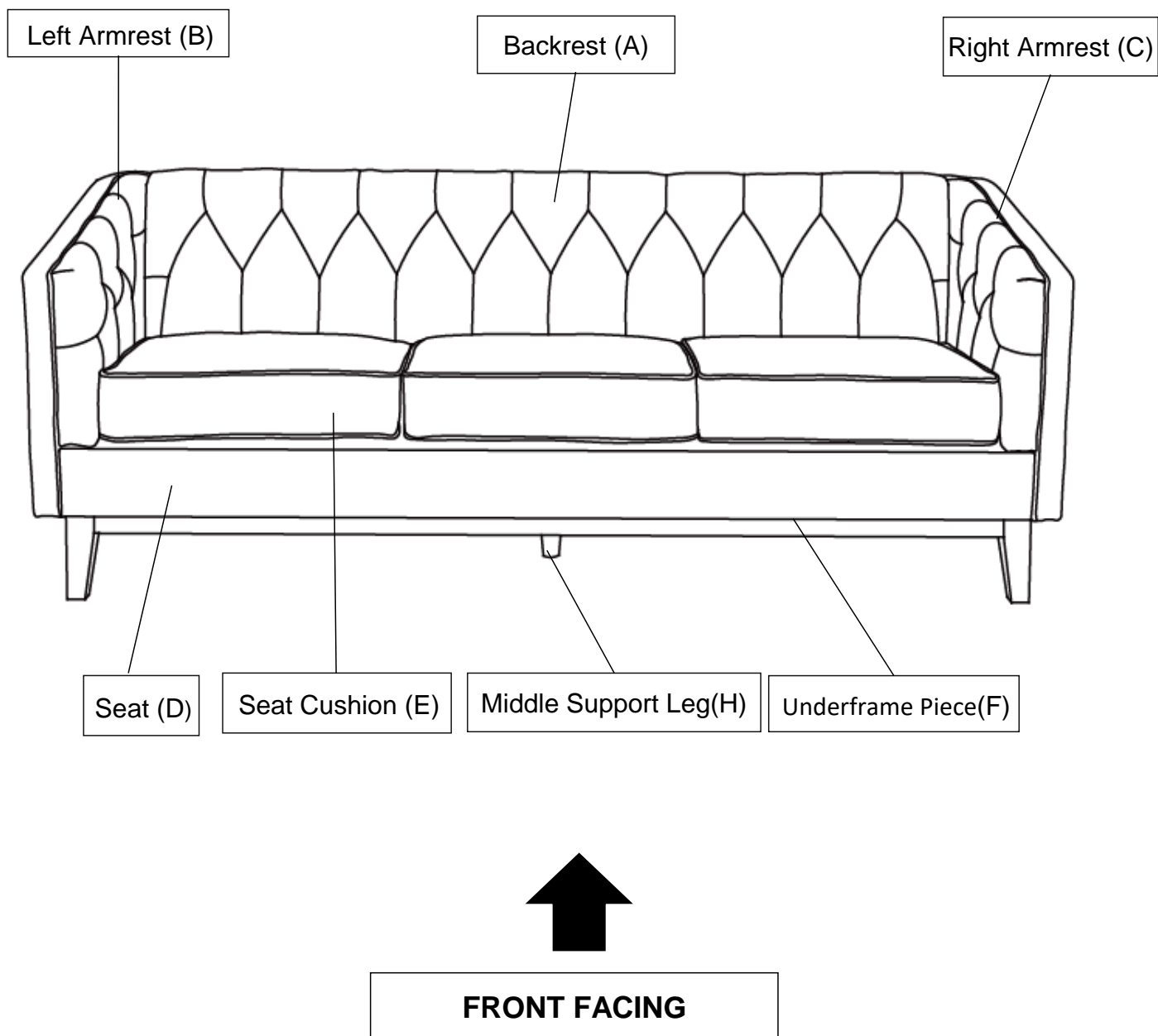

This Sofa has multiple parts and may require up to 60 minutes to assemble. To give you an overview of the Sofa parts, the above picture is to help you put the various parts into perspective. Please read through the instructions below to familiarise yourself with the parts and steps before assembly.

Note: It is recommended that you have an adult partner to assist during the entire assembly process.

Step 1

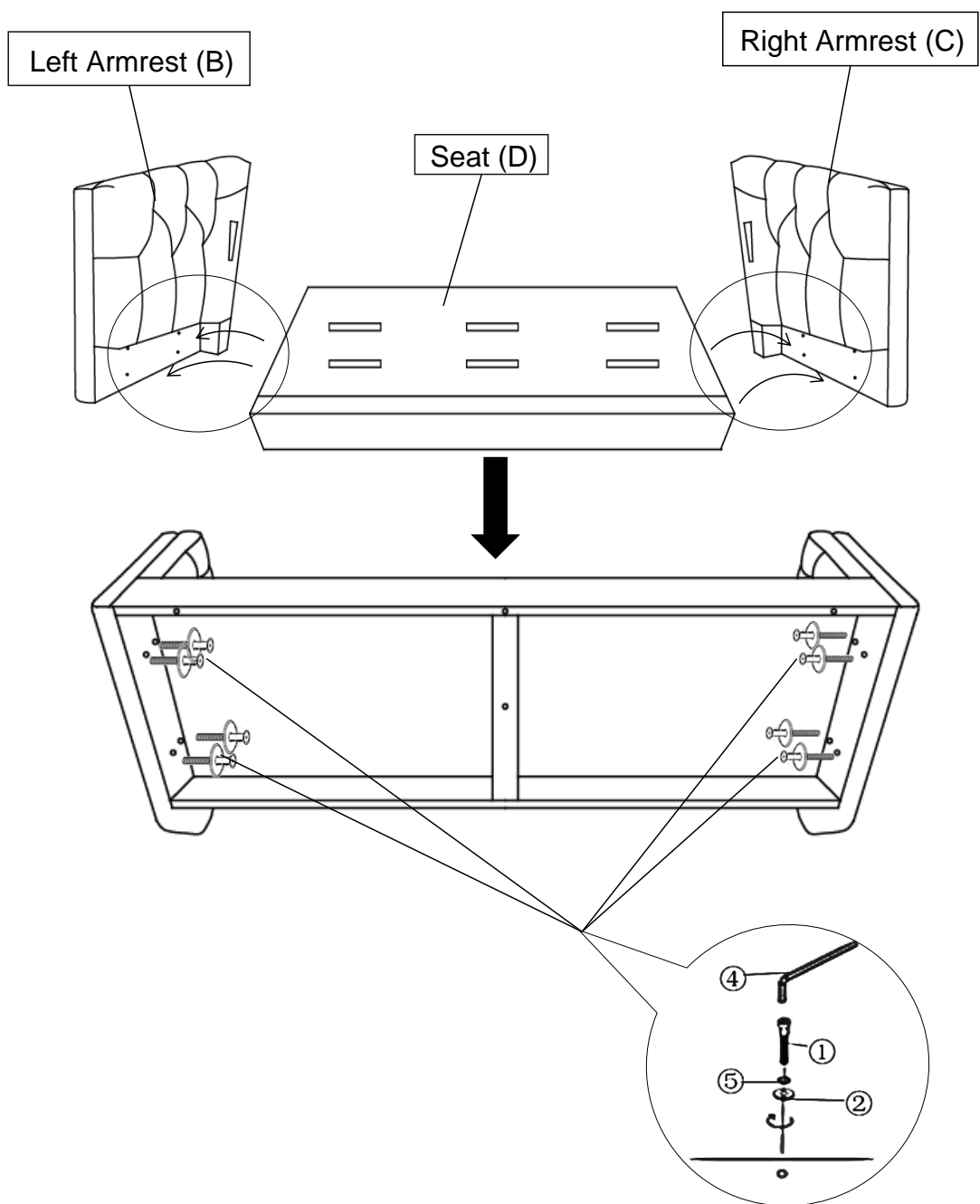

Open the carton and place all the parts on a clean, non-marring surface.

With the assistance from your partner, attach the Seat(D) to the Left Armrest (B) & the Right Armrest(C) using the Bolts(①), Spring Washers(③), and Ø30 Washers(②) with the Allen Wrench(④) as pictured above.

Tighten the Bolts fully in a sequential manner.

DO NOT fully tighten a Bolt in one go and then move on to the next.

Rather, In a sequential manner, gradually tighten each Bolt little by little until all Bolts are evenly secured.

This methodology will ensure maximum evenness once all Bolts are fully tightened.

Make sure the bottoms of the Seat(D) and the Left Armrest (B) & the Right Armrest(C) are level.

Assistance from an adult partner is needed for this assembly process.

Caution: Ensure that your fingers do not get caught or pinched in the assembly process.

Step 2

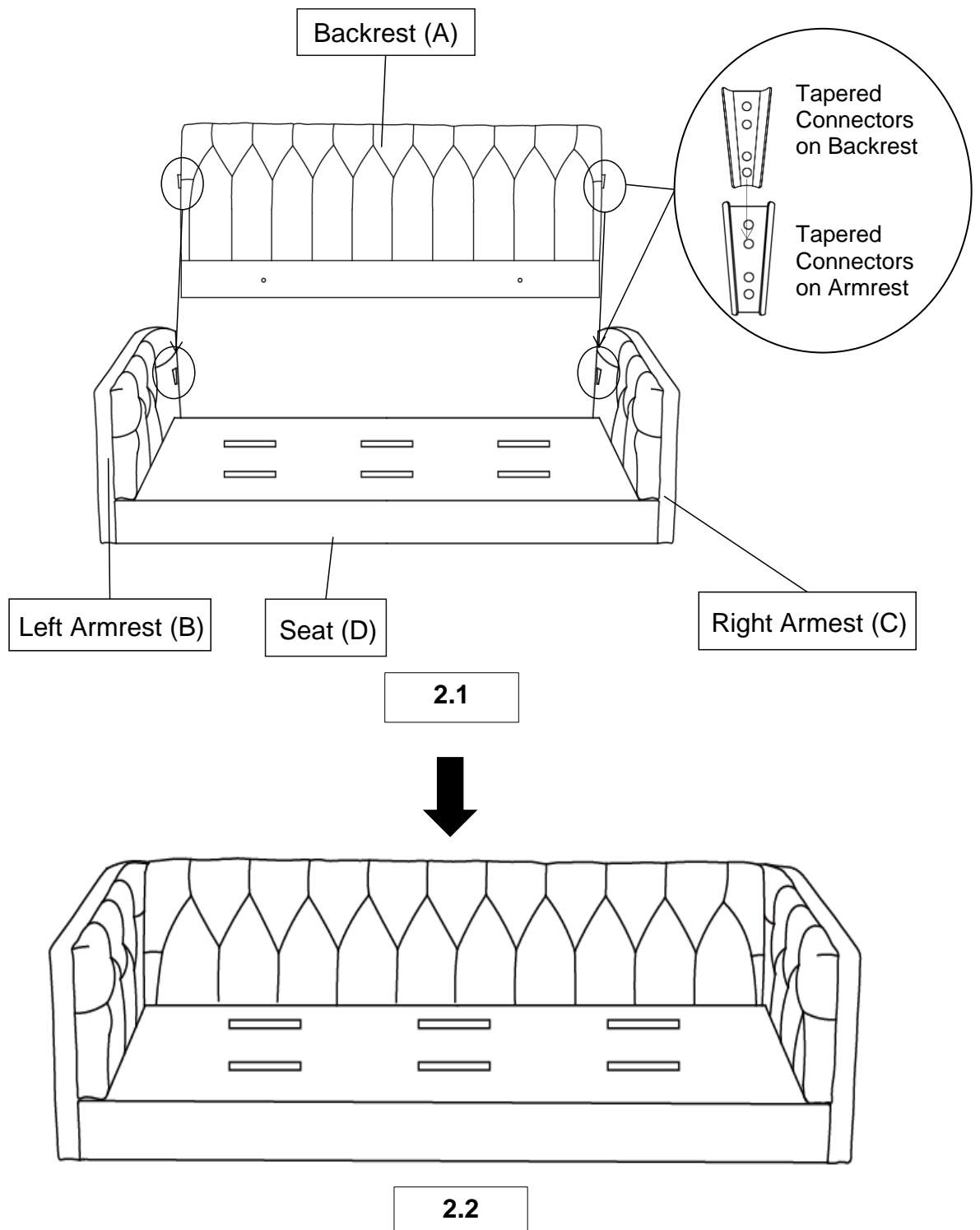

With the assistance from your partner.

2.1) Lift the Backrest(A) up, make sure the Backrest(A) is vertical and aligned with the Seat and Armrest. Align the Tapered Connectors on the Backrest(A) with those on the Left Armrest(B) and Right Armrest(C). Your adult partner may need to push the Armrests inwards towards the Backrest(A) to allow for better alignment.

Slip and slide the Backrest, in a gradual and balanced manner into the Tapered Connectors.

2.2) Push the Backrest(A) downwards until it is fully slotted and locked into position.

Note: Make sure the Tapered Connectors on the Backrest(A) lock into the Tapered Connectors on Left Armrest(B) and Right Armrest(C).

Fully locked position: Check and assess that the base of the Backrest (A) and Seat(D) are aligned and level.

Assistance from an adult partner is needed for this assembly process.

Step 3

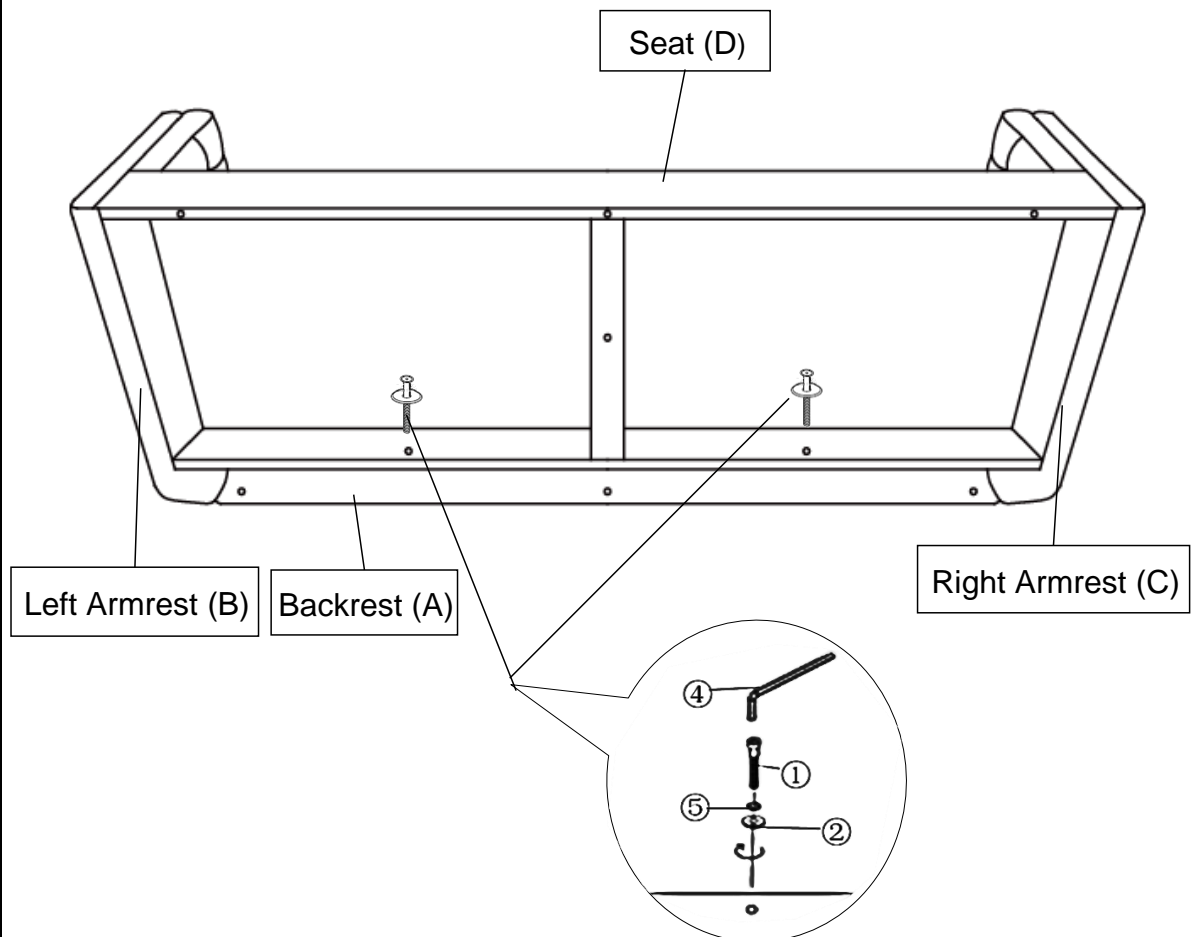

Tilt and lay the Sofa on its Backrest(A) onto a flat surface.

Attach Seat(D) to Backrest(A) using Bolts(①), Spring Washers(⑤), and Ø30 Washers(②) with Allen Wrench (④).

Tighten the Bolts fully in a sequential manner.

DO NOT fully tighten a Bolt in one go and then move on to the next.

Rather, In a sequential manner, gradually tighten each Bolt until all Bolts are evenly secured. This methodology will ensure maximum evenness once all Bolts are fully tightened.

Note: If you can not insert the Bolts into position, please back to Step 2 to "push Backrest downwards".

Step 4

4.1

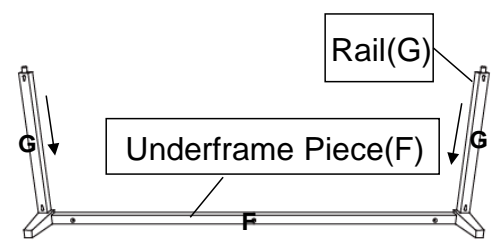
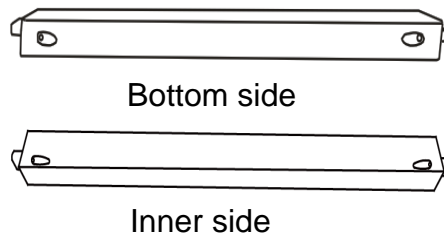

4.2

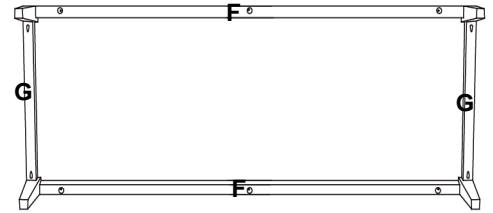

4.3

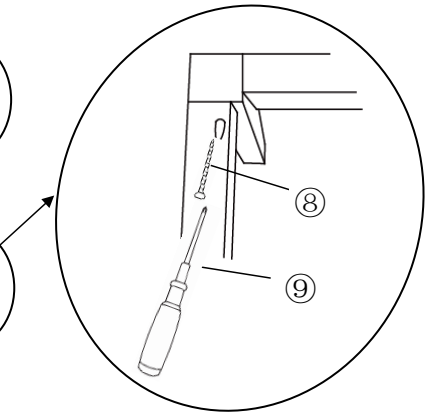
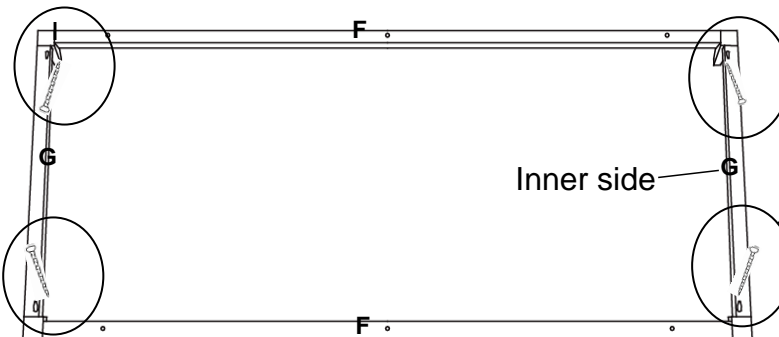
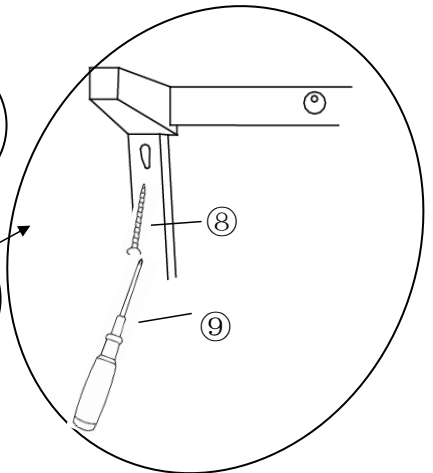
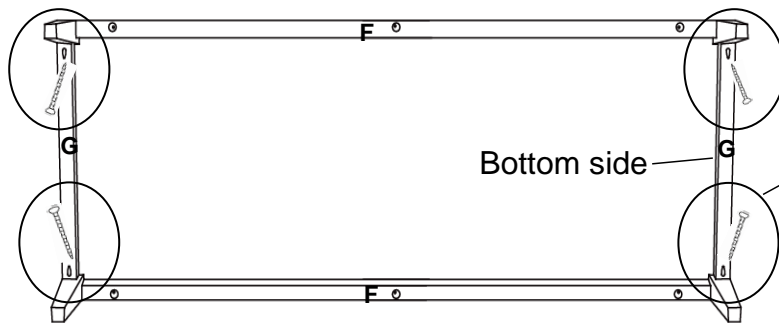

4.1) Insert the Rails(G) into the oval mounting Position of Underframe Piece(F) as shown above picture.
Note: Notice the direction label on the Rails or the location of the mounting Positions on the Rails (on the bottom side, the mounting Positions are positioned in the middle of the edges of the rail, and on the inner side, the mounting Positions are near the inner edges of the rail)

4.2) Then, attach the other Underframe Piece(F) to the Step 4.1 semi-assembled parts as shown in the picture above.

4.3) Put the assembled frame facedown on a clean, non-marring surface (with the four legs facing upwards).

Screw in Screws(8) with Screwdriver(9) as pictured on the bottom side.

Turn over the assembled frame, screwing in Screws(8) with Screwdriver(9) as pictured on the upper side.

Note: Before screwing, make sure the Rails(G) are inserted Underframe Piece(F) entirely.

Step 5

5.1

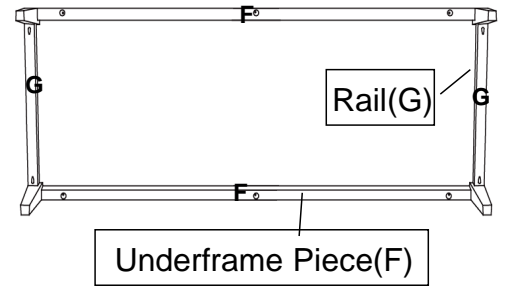
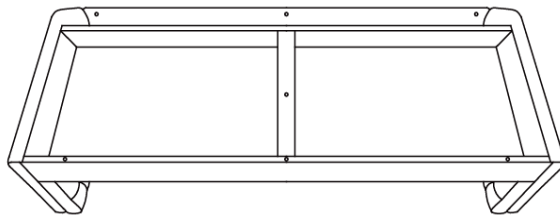

5.2

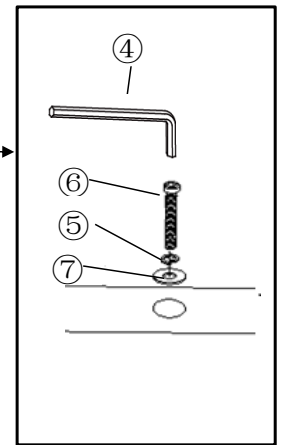
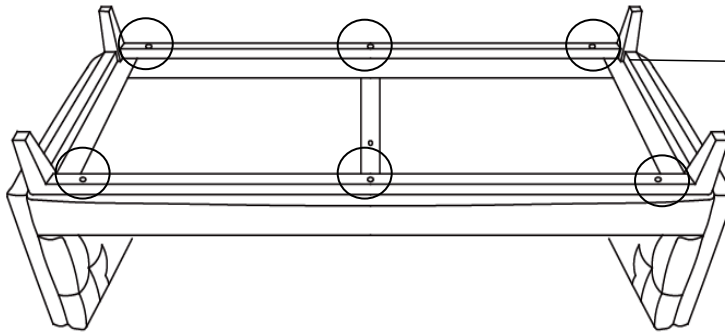

5.1) Put the sem-assembled sofa in Step 3 facedown onto a clean, non-marring surface.

5.2) Align the mounting positions of the sem-assembled sofa in Step 3 with the assembled underframe in Step 4, then attach using Bolts(6), Spring Washers(5) & Ø16 Washers(7) with Allen Wrench(4).

Tighten the Bolts fully in a sequential manner.

DO NOT fully tighten a Bolt in one go and then move on to the next.

Rather, In a sequential manner, gradually tighten each Bolt little by little until all Bolts are evenly secured.

Important Hint:

If you find the mounting position on the underframe can not match the mounting position underneath the sofa. Then you need to go back to Step 3 and use the Allen Wrench(4) to loosen the bolts between the Seat(D) and the Backrest(A) a little, so it would be easier to carry out Step 5.2

Please remember to tighten the bolts between the Seat(D) and the Backrest(A) after affixing the underframe to the sofa.

Step 6

Use Gaskets (③) to achieve stability

Middle Support Leg (H)

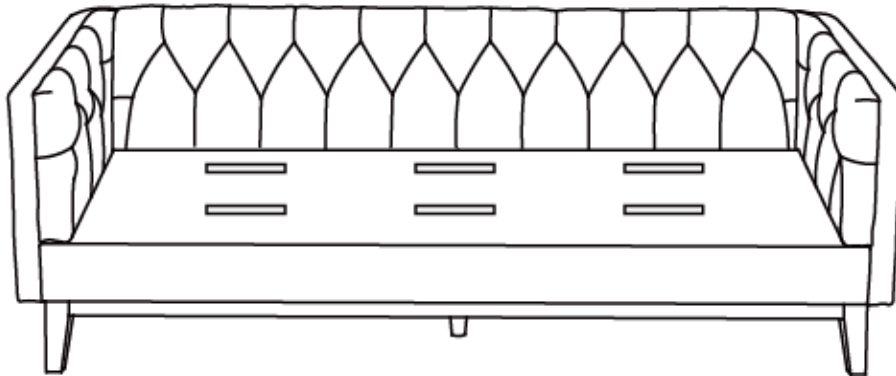
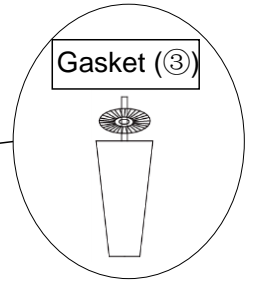
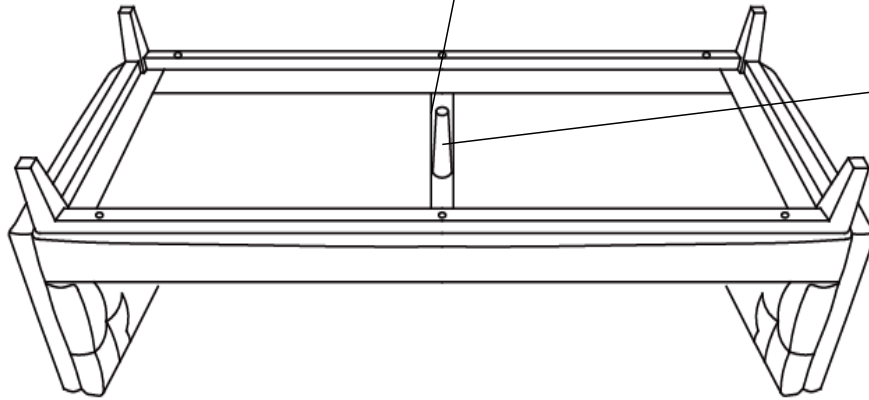

Install the Middle Support Leg (H) at the bottom of the Sofa by placing one Gasket(③) on the threaded stem. Then insert the threaded stem into the threaded mounting position at the corners of the Sofa. Tighten by turning the Leg clockwise.

Note: The use of Gaskets are OPTIONAL and are especially useful to help alleviate slight wobbles. Some Legs may need more than one whilst some Legs may not need any.

Step 7

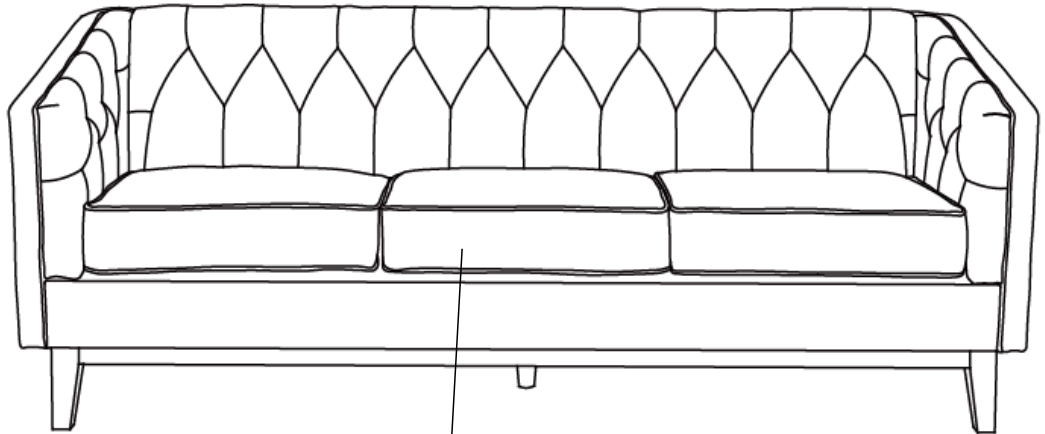

Seat Cushion (E)

Place the Seat Cushions(E) onto the Sofa.
Your Sofa is ready for use.
This Sofa can only be used on a flat, level surface.

Care & Maintenance



- Furniture may scratch floors. We recommend using furniture pads to protect your floors.



- Do not put hot items directly on furniture surface.



- Do not clean furniture with harsh cleansers or polish.



- Do not place furniture under direct sunlight.



- Do not place furniture near heating or cooling vents.



- Do not write on furniture without a padded barrier to protect the surface.



- Do not place furniture outside . For indoor use only.



- Not for commercial use. For residential use only.



- Stains may be removed with mild soap solution and damp cloth.



- Children should not climb or jump on the furniture.



- Dust and pick-up spills using a clean, non-colored, lint-free cloth.