

Computer Desk (Cottage Oak)

IMPORTANT NOTE

Carefully remove all the parts from the carton and put them individually on a soft cloth to prevent scratches or other damages occurring to the wood parts.

We have taken great care in the design of this product and request that you carefully and strictly follow our assembly instructions to ensure a completed product as it was designed.

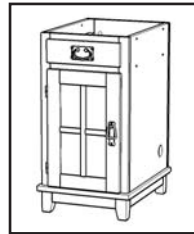

Left Unit

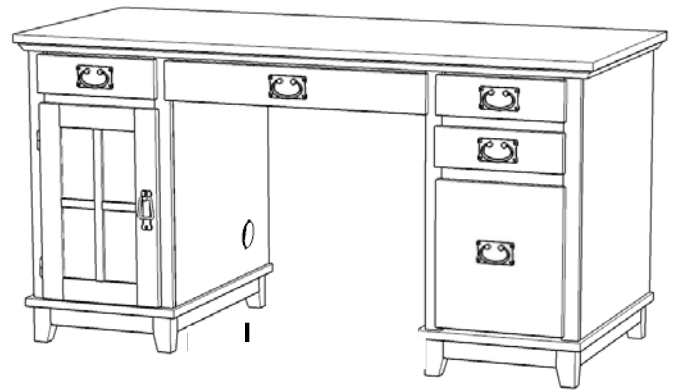

Left Unit Part List

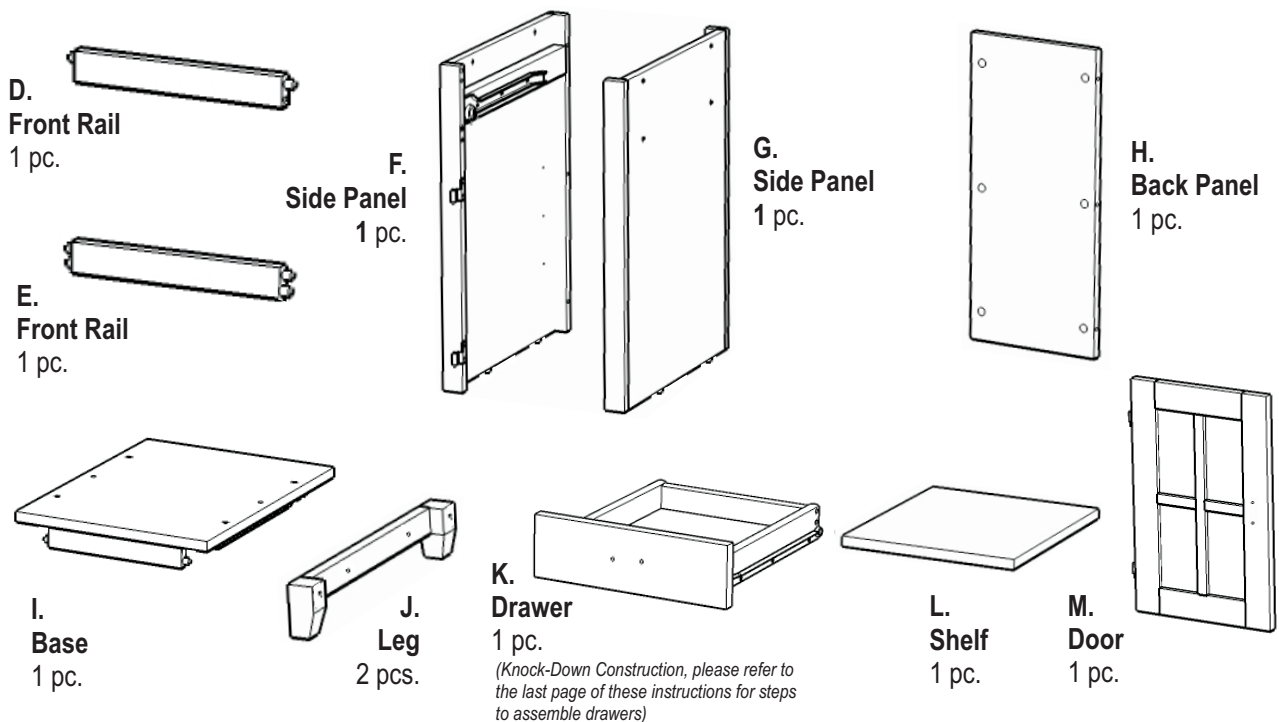

Hardware List

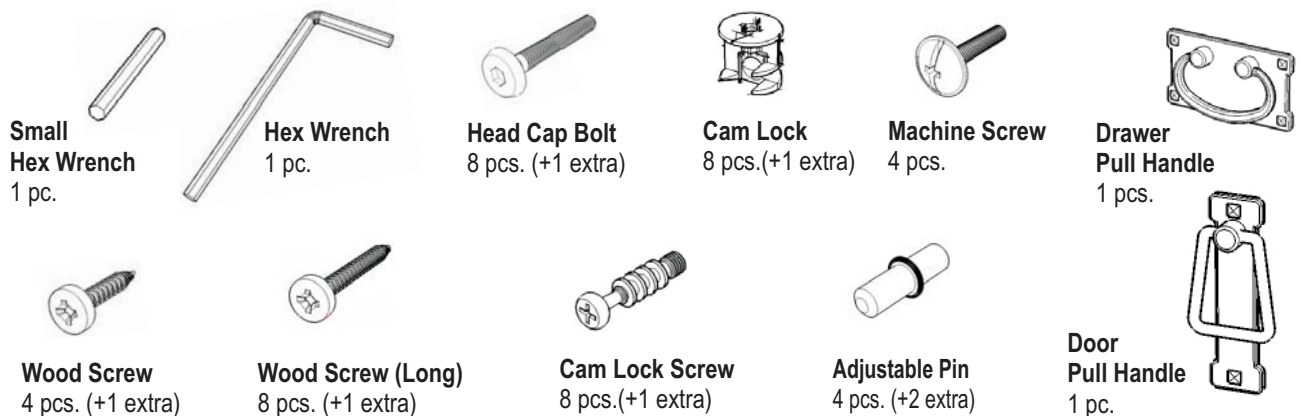

Tools required for assembly : **Phillips** screwdriver

IMPORTANT

Do not tighten up all the screws until each part is properly assembled.

You should keep Hex Wrench in the safe place as you may need to tighten up the Head Cap Bolts in the future.

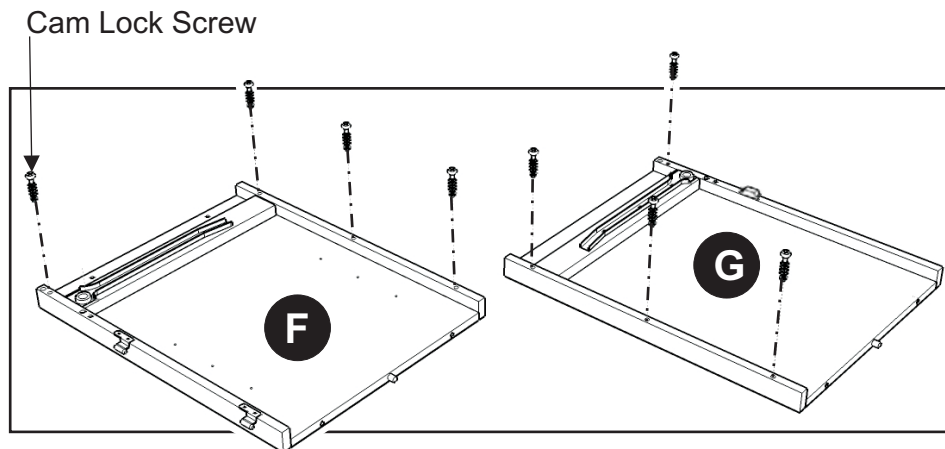

STEP 1

Put Cam Lock Screws into the pre-drilled holes of Side Panel (F),(G) and tighten.

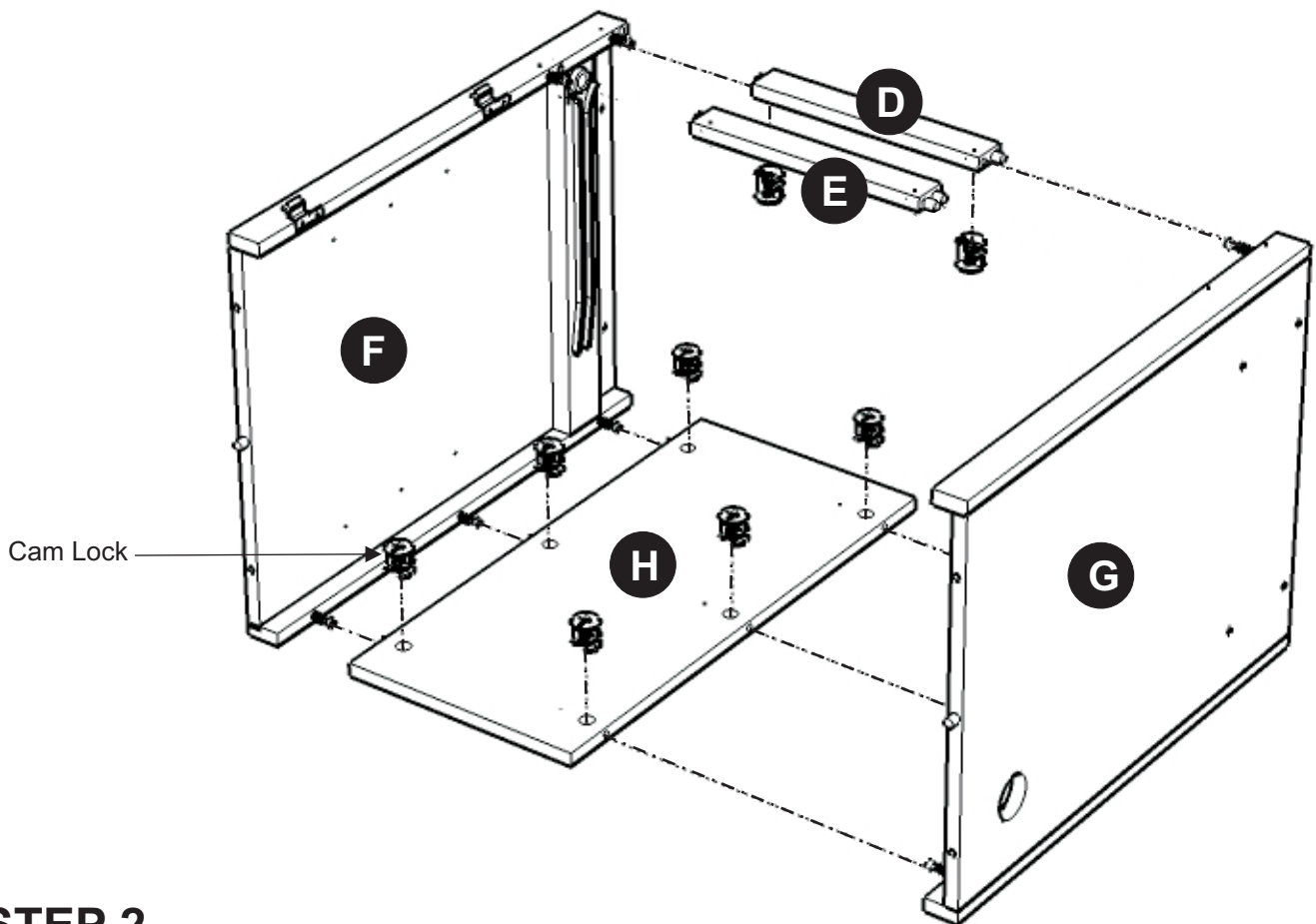

STEP 2

Attach Front Rails (D), (E) and Back Panel (H) to Side Panel (F) using Cam Locks.

Attach Side Panel (G) to the unit using Cam Locks.

STEP 3

Attach Base (I) to the unit with Head Cap Bolts.

Attach Leg (J) to Base (I) with Head Cap Bolts.

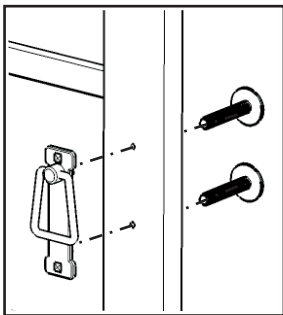

(Figure 1)

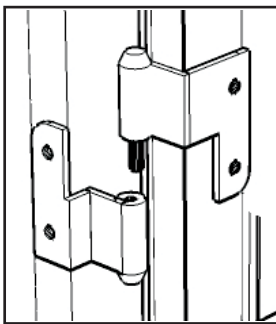

(Figure 2)

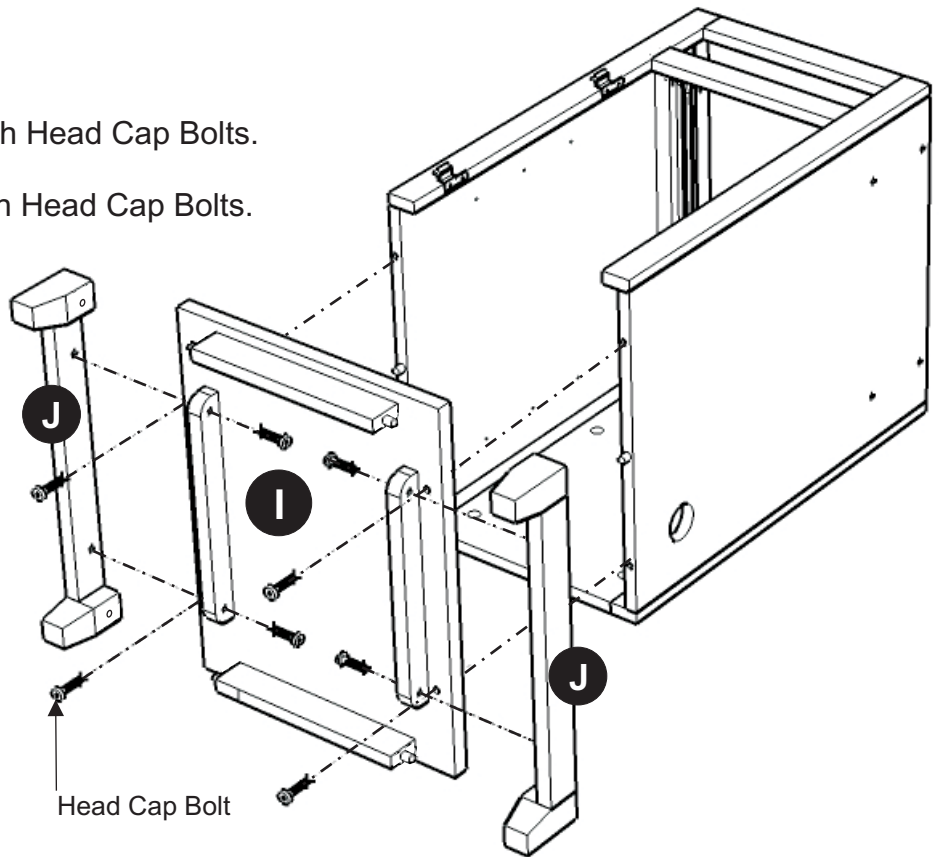

STEP 4

Turn the unit to its upright position.

Slide Drawer (K) into place.

Insert Adjustable Pins Into both side panels at the desired level.

Slide Shelf (L) into place.

Assemble Pull Handle to Door (M) with Machine Screws. (see Figure 1)

Attach Door (M) to the side panels by sliding the door lift hinges into the side panel lift hinges. (see Figure 2)

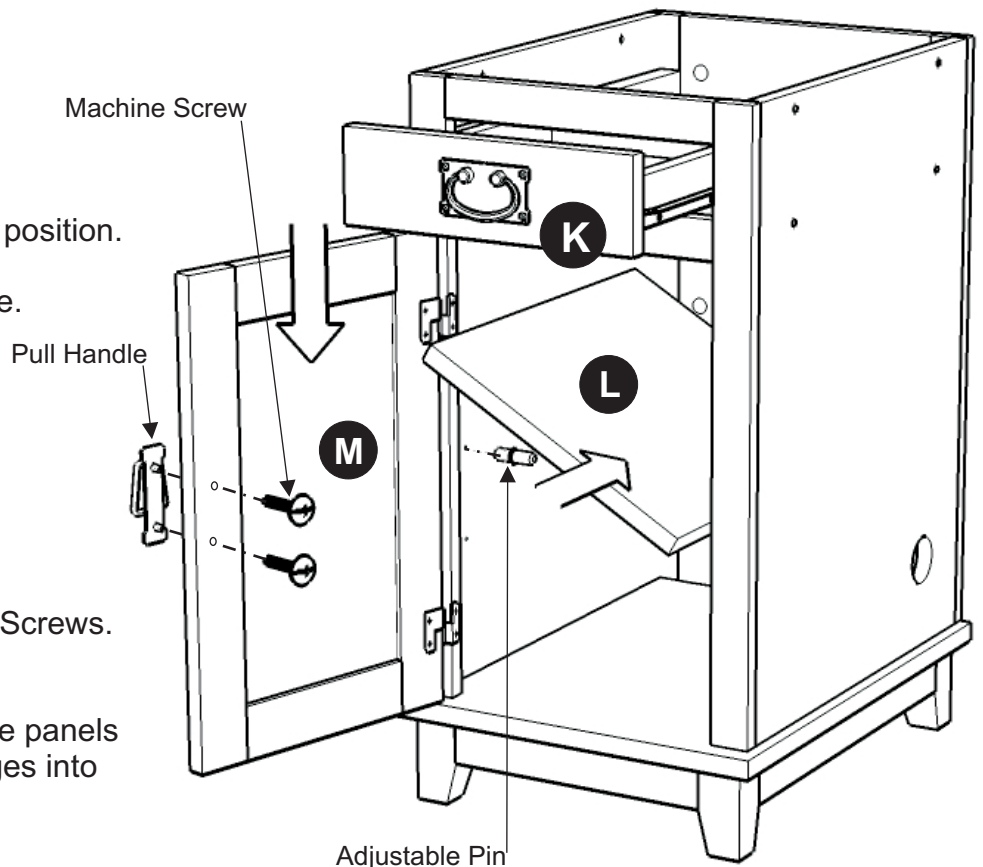

Drawer (K)

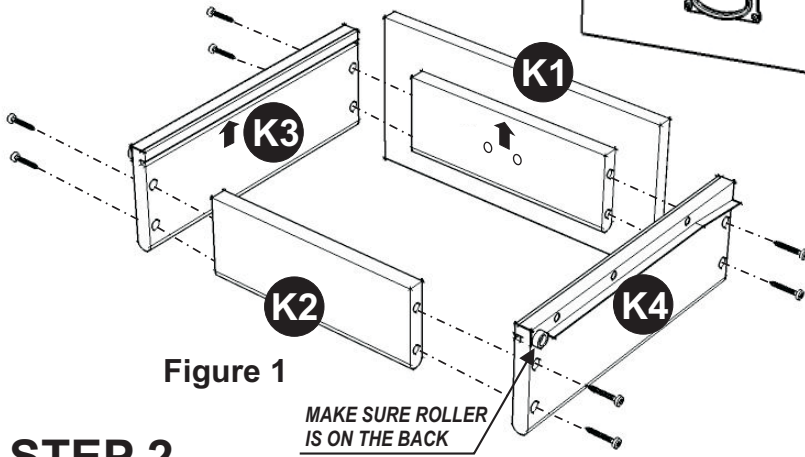

Figure 1

STEP 1

Attach K1 to K3 and K4, using a Phillips screwdriver and long wood screws (4X), tighten halfway.

Attach K2 to K3 and K4 using long wood screws (4X), tighten halfway. (see Figure 1)

STEP 2

Slide K5 into the grooves in K3 and K4. Be sure to push K5 all the way forward so it meets K1. (see Figure 2)

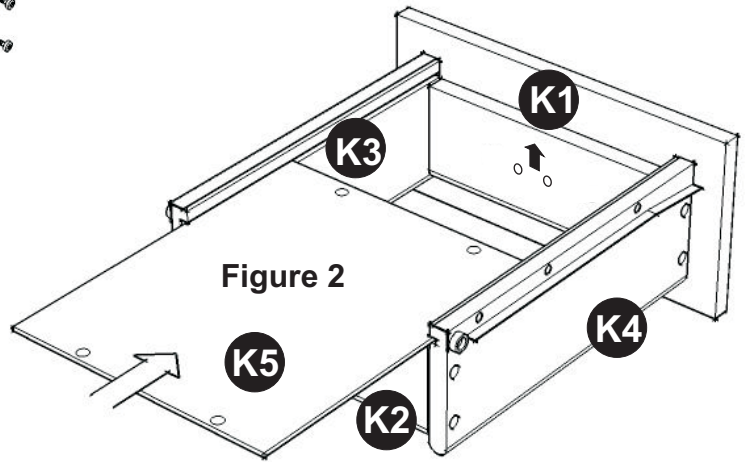

Figure 2

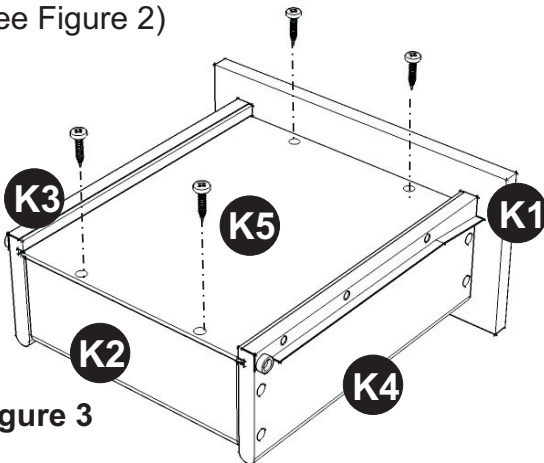

Figure 3

STEP 3

Insert short wood screws (6X) into the pre-drilled holes in K5, tighten screws. (see Figure 3)

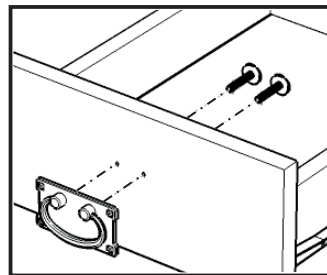

Figure 4

STEP 4

Attach hardware pulls with machine screws. (see Figure 4)

Tighten all screws used in drawer assembly.

Part List

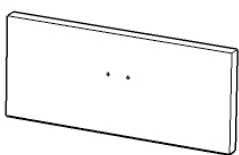

K1.
Front Part
1 pc.

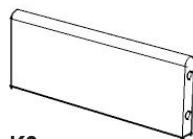

K2.
Back Part
1 pc.

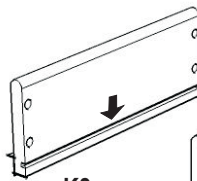

K3.
Side Part
1 pc.

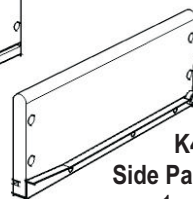

K4.
Side Part
1 pc.

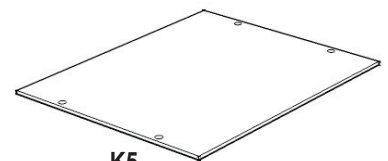

K5.
Base Part
1 pc.

Computer Desk (Cottage Oak)

IMPORTANT NOTE

Carefully remove all the parts from the carton and put them individually on a soft cloth to prevent scratches or other damages occurring to the wood parts.

We have taken great care in the design of this product and request that you carefully and strictly follow our assembly instructions to ensure a completed product as it was designed.



Right Unit

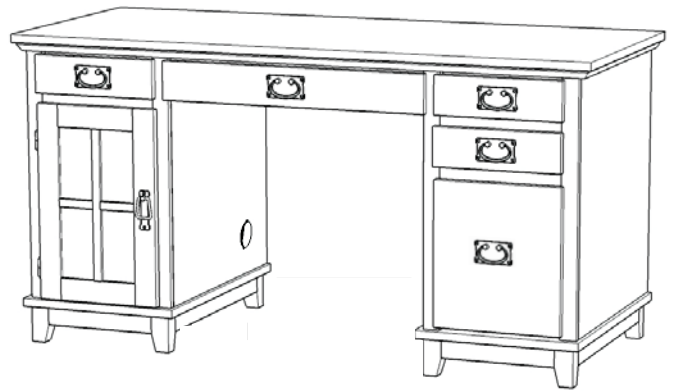

Right Unit Part List

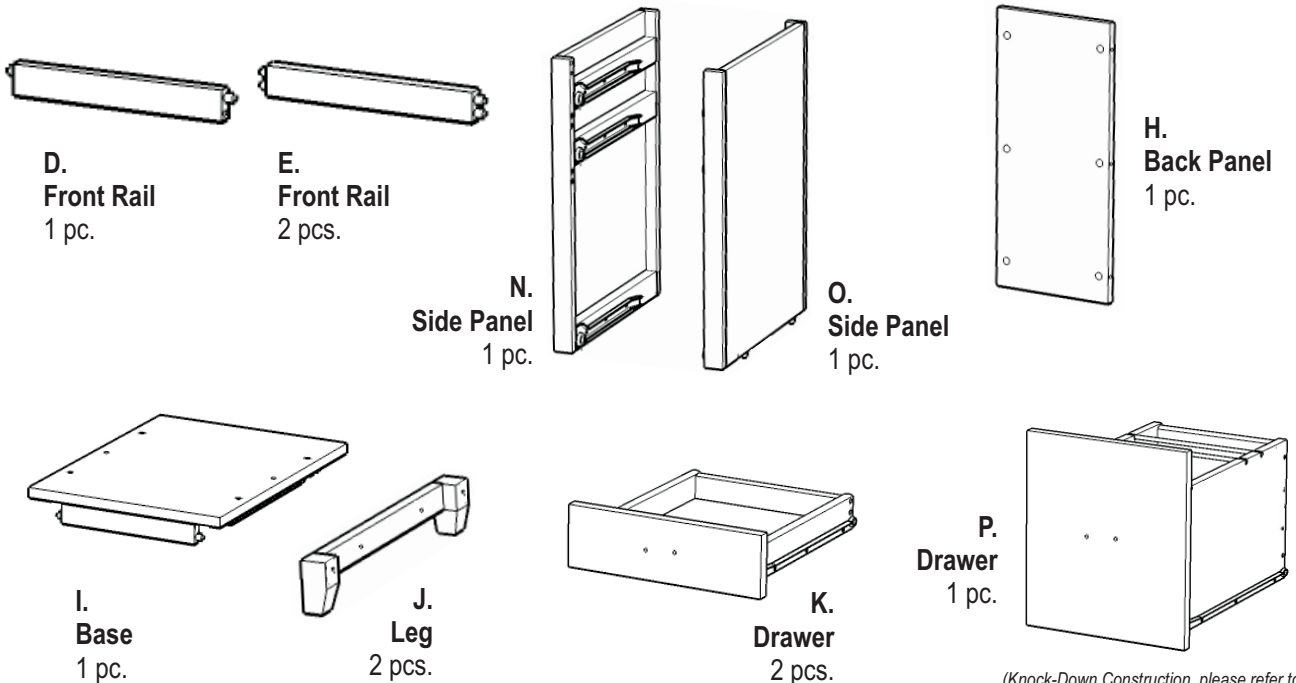

(Knock-Down Construction, please refer to the last page of these instructions for steps to assemble drawers)

Hardware List

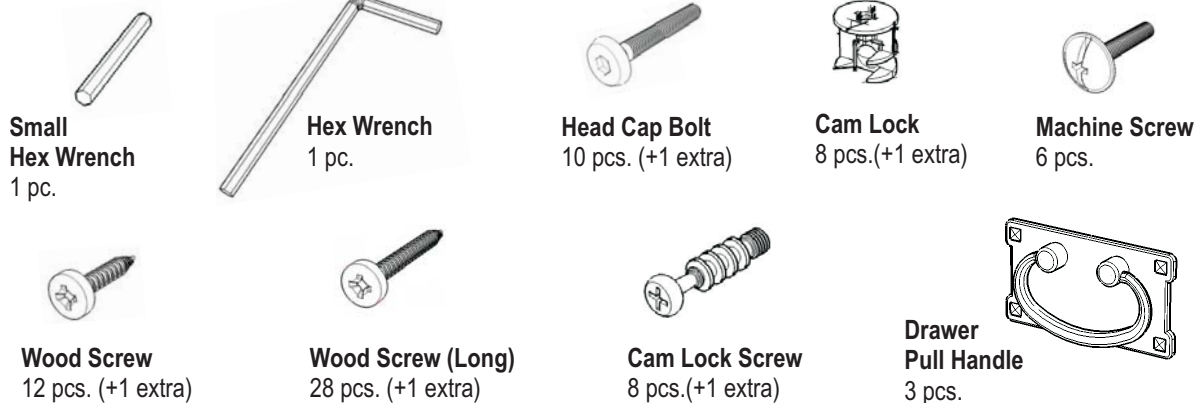

Tools required for assembly : **Phillips** screwdriver

IMPORTANT

Do not tighten up all the screws until each part is properly assembled.

You should keep Hex Wrench in the safe place as you may need to tighten up the Head Cap Bolts in the future.

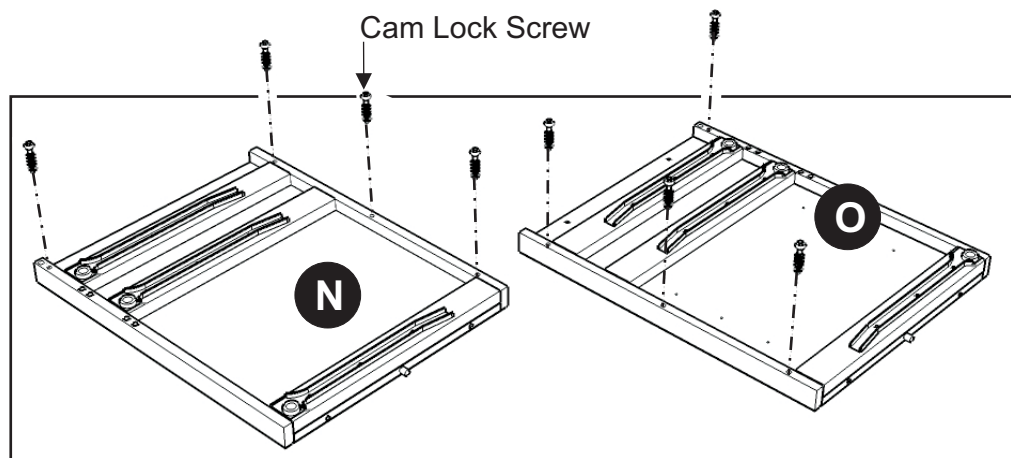

STEP 1

Put Cam Lock Screws into the pre-drilled holes of Side Panel (N), (O) and tighten.

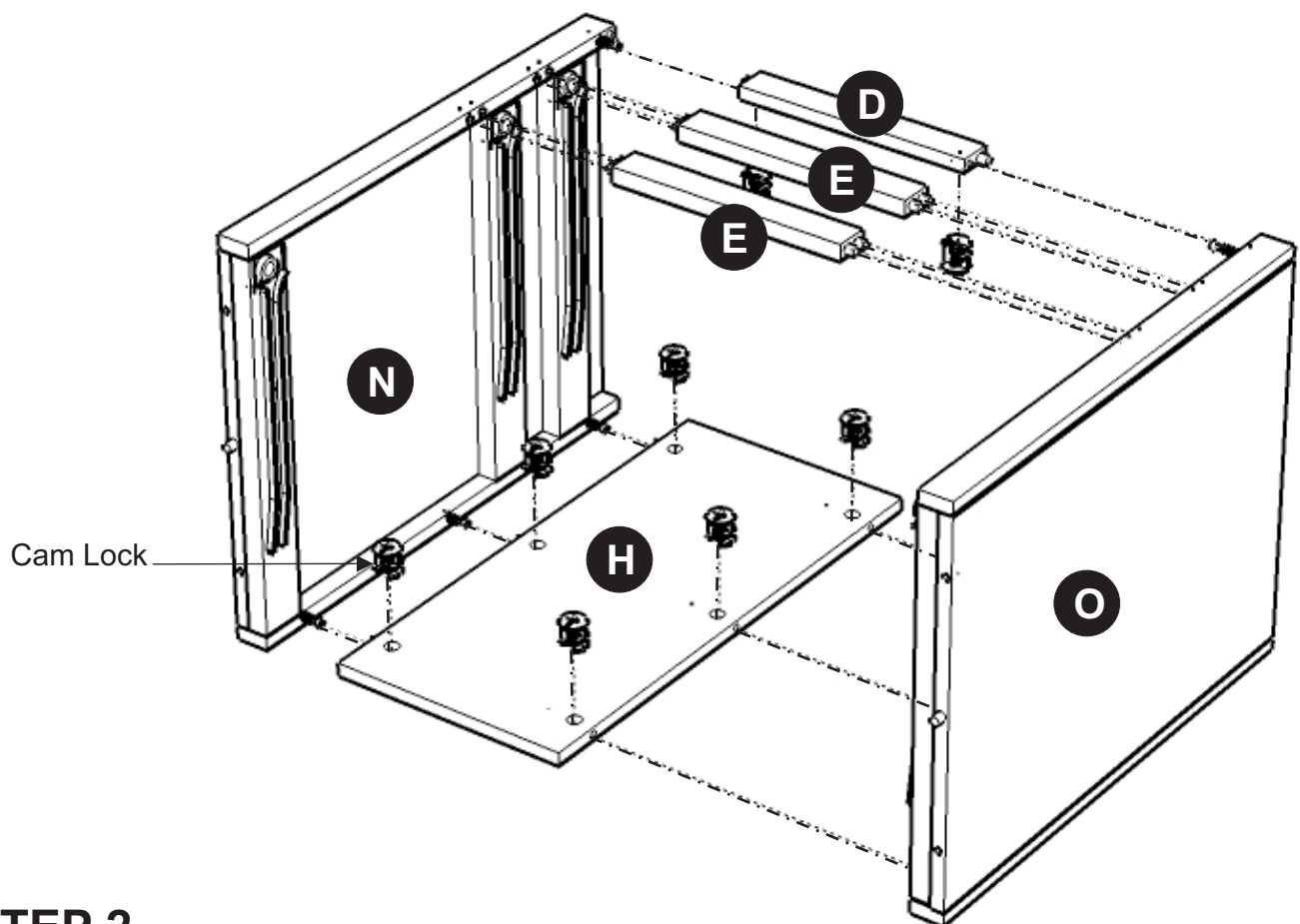

STEP 2

Attach Front Rail (D), (E) Back Panel (H) to Side Panel (N) using Cam Locks.

Attach Side Panel (O) to the unit using Cam Locks.

STEP 3

Attach Base (I) to the unit with Head Cap Bolts.

Attach Leg (J) to Base (I) with Head Cap Bolts.

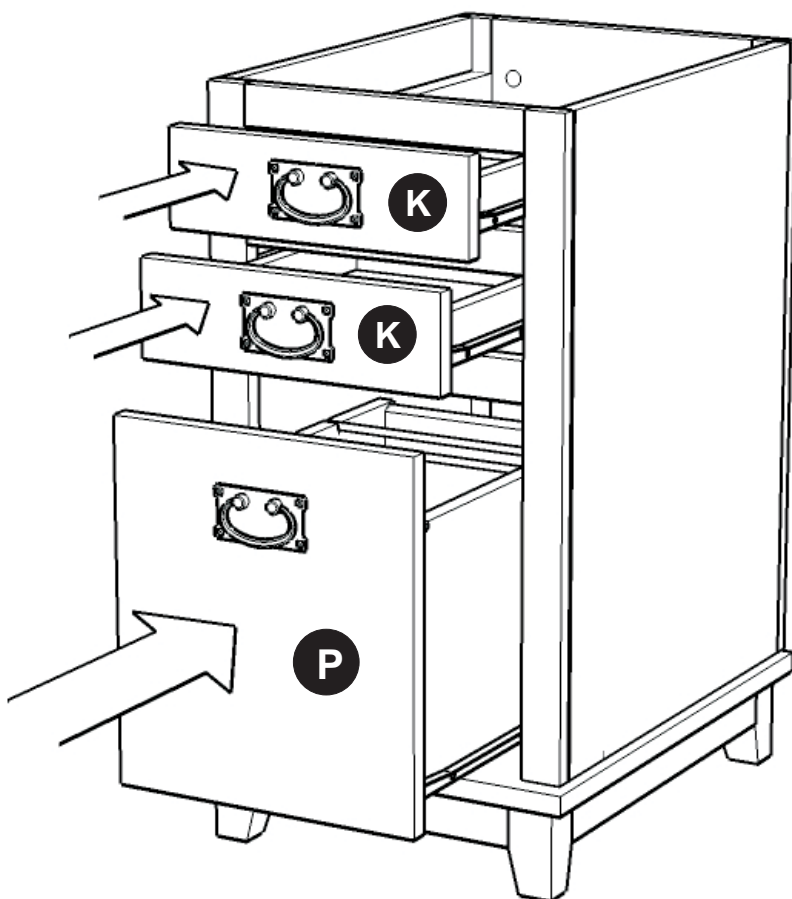
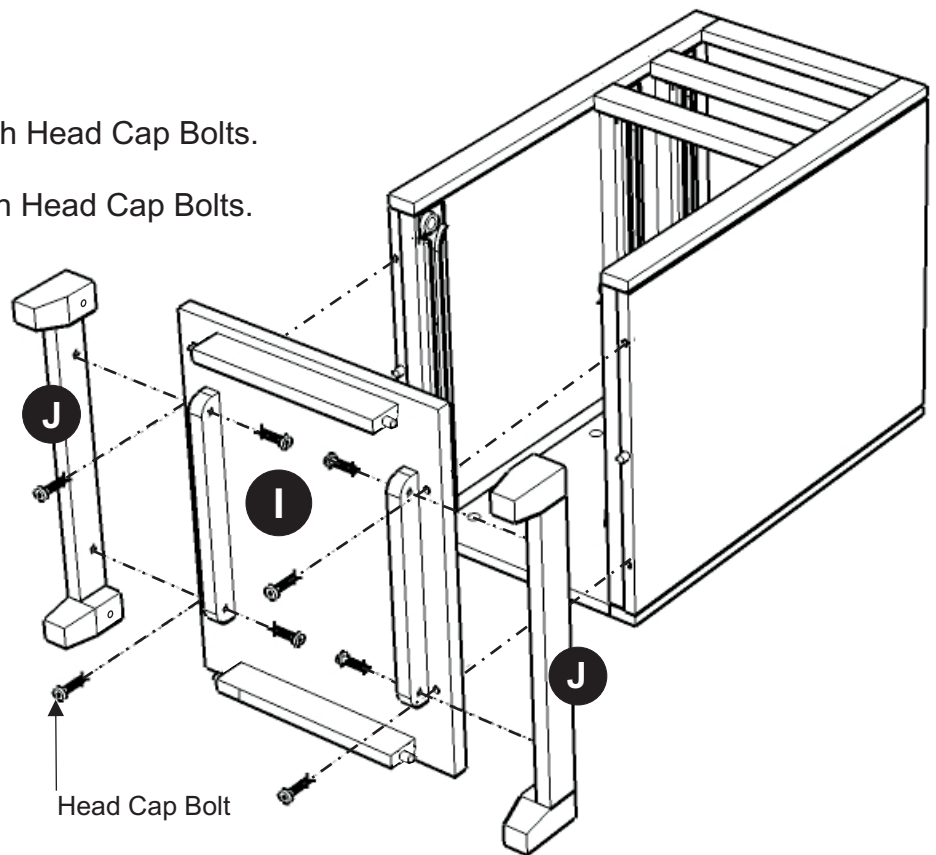

STEP 4

Turn the unit to its upright position.

Slide Drawer (K) and (P) into place.

Drawer (K)

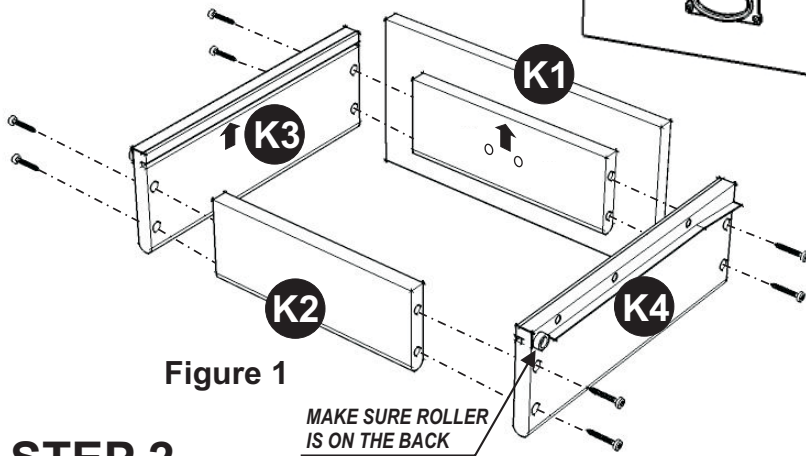

Figure 1

STEP 1

Attach K1 to K3 and K4, using a Phillips screwdriver and long wood screws (4X), tighten halfway.

Attach K2 to K3 and K4 using long wood screws (4X), tighten halfway. (see Figure 1)

STEP 2

Slide K5 into the grooves in K3 and K4. Be sure to push K5 all the way forward so it meets K1. (see Figure 2)

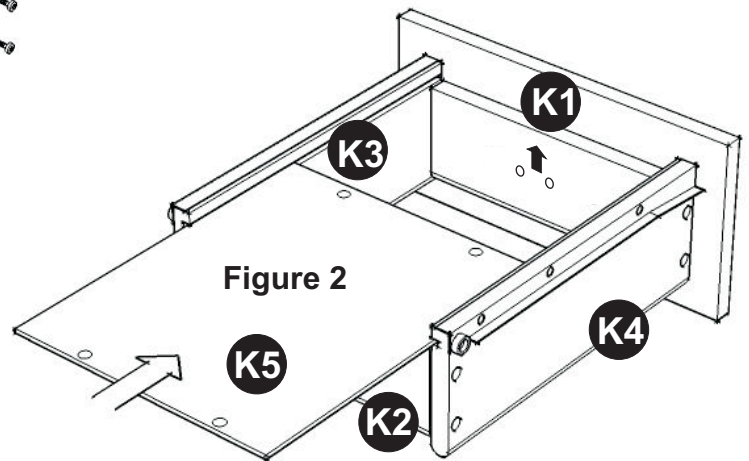

Figure 2

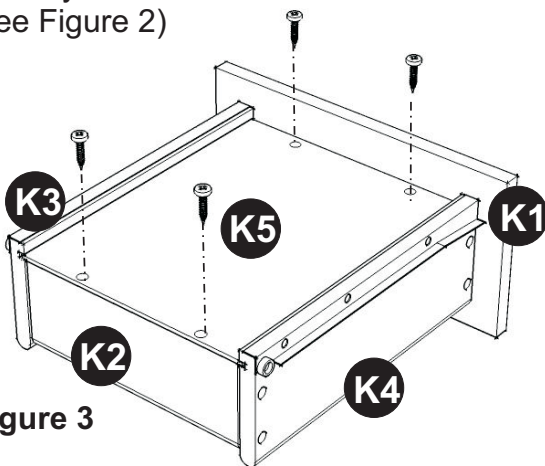

Figure 3

STEP 3

Insert short wood screws (6X) into the pre-drilled holes in K5, tighten screws. (see Figure 3)

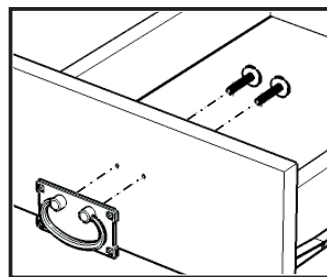

Figure 4

STEP 4

Attach hardware pulls with machine screws. (see Figure 4)

Tighten all screws used in drawer assembly.

Part List

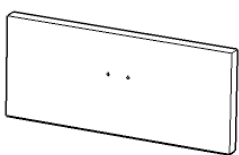

K1.
Front Part
2 pcs.

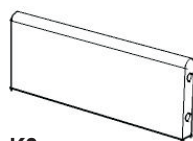

K2.
Back Part
2 pcs.

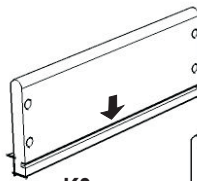

K3.
Side Part
2 pcs.

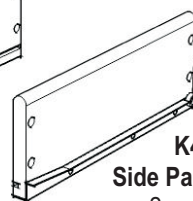

K4.
Side Part
2 pcs.

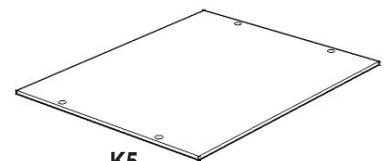

K5.
Base Part
2 pcs.

Drawer (P)

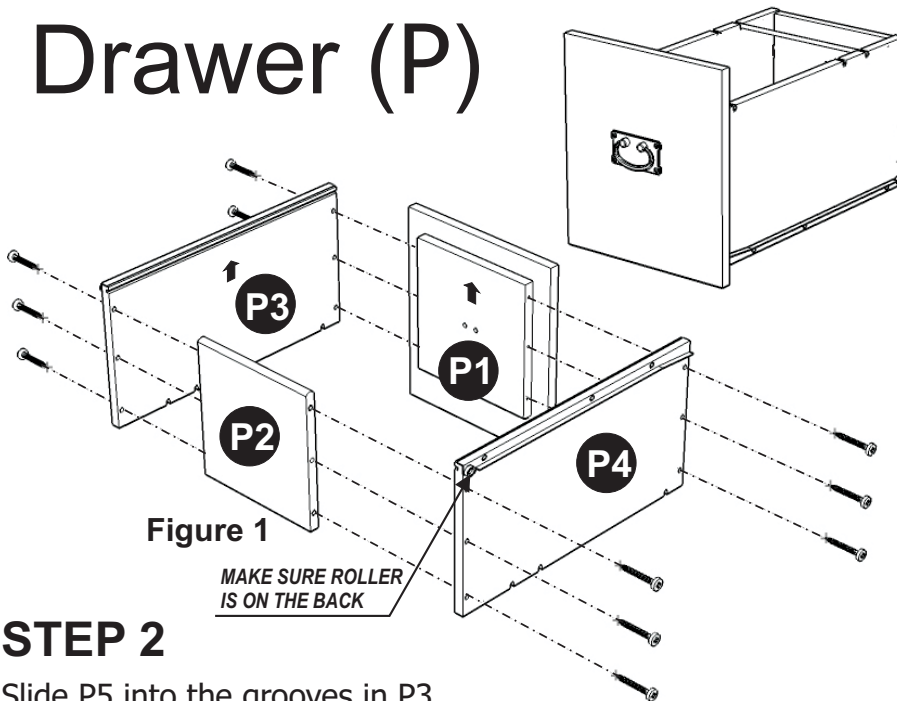

Figure 1

MAKE SURE ROLLER IS ON THE BACK

STEP 1

Attach P1 to P3 and P4, using a Phillips screw driver and long wood screws (8X), tighten halfway.

Attach P2 to P3 and P4 using long wood screws (8X), tighten halfway. (see Figure 1)

STEP 2

Slide P5 into the grooves in P3 and P4. Be sure to push P5 all the way forward so it meets P1. (see Figure 2)

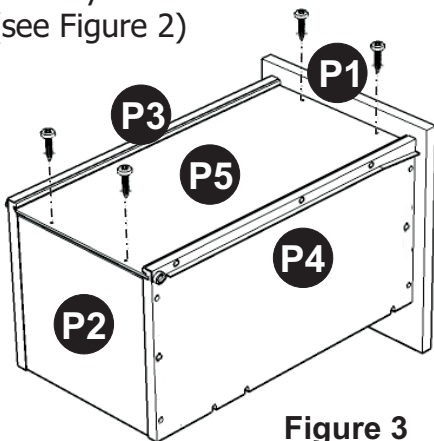

Figure 3

STEP 3

Insert short wood screws (4X) into the pre-drilled holes in P5, tighten screws. (see Figure 3)

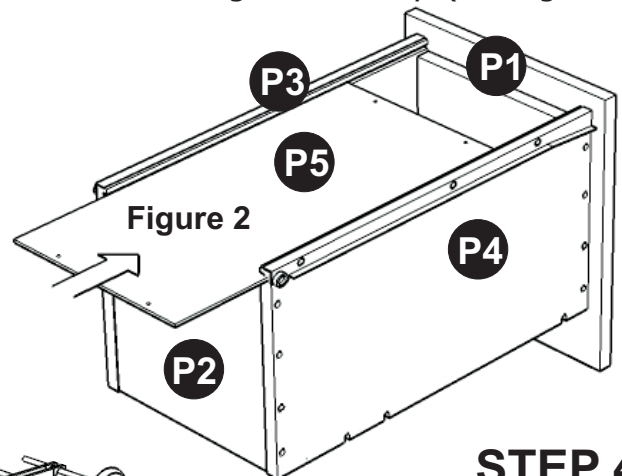

Figure 2

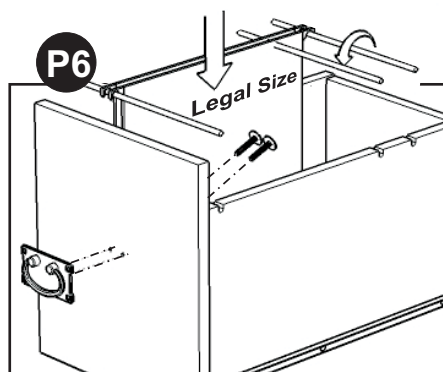

Figure 4

STEP 4

Attach hardware pulls with machine screws.

Remove the tape holding the Metal Strips in place.

You can adjust the Metal Strip for letter size or legal size file as shown. (see Figure 4)

Tighten all screws used in drawer assembly.

Part List

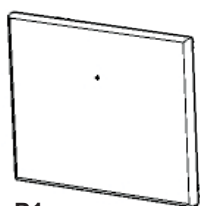

P1.
Front Part
1 pc.

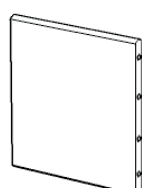

P2.
Back Part
1 pc.

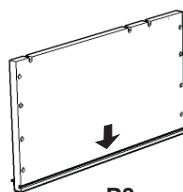

P3.
Side Part
1 pc.

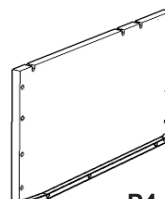

P4.
Side Part
1 pc.

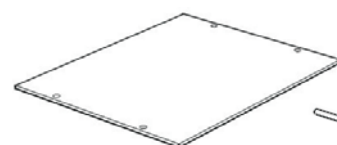

P5.
Base Part
1 pc.



P6.
Metal Strip
2 pcs.

Computer Desk (Cottage Oak)

IMPORTANT NOTE

Carefully remove all the parts from the carton and put them individually on a soft cloth to prevent scratches or other damages occurring to the wood parts.

We have taken great care in the design of this product and request that you carefully and strictly follow our assembly instructions to ensure a completed product as it was designed.

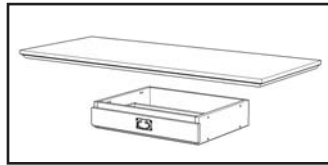

Top Unit

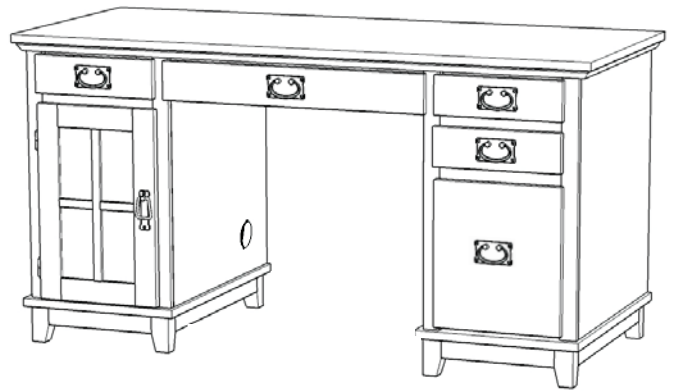

Top Unit Part List

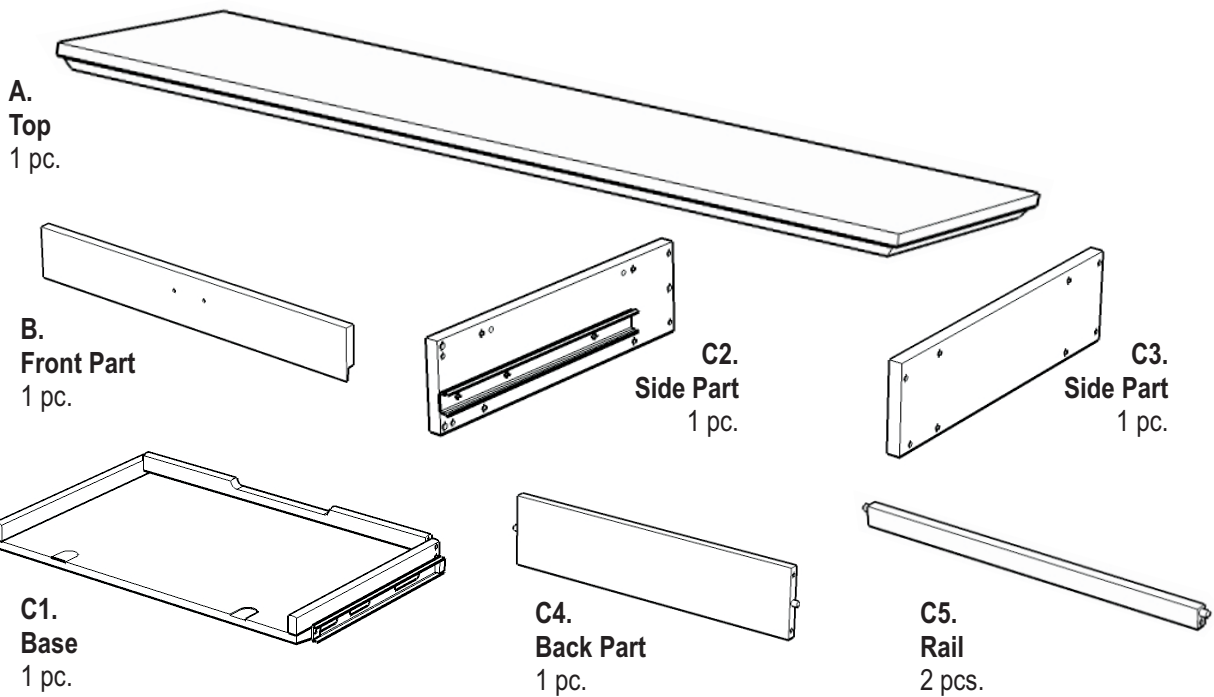

Hardware List

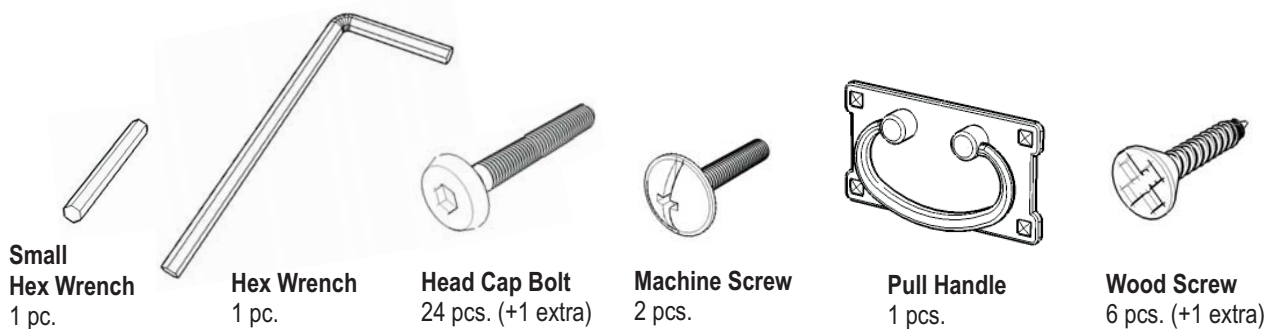

Tools required for assembly : **Phillips** screwdriver

IMPORTANT

Do not tighten up all the screws until each part is properly assembled.

You should keep Hex Wrench in the safe place as you may need to tighten up the Head Cap Bolts in the future.

STEP 1

Attach Rail (C5) and Back Part (C4) to Side Part (C2) with Head Cap Bolts, then attach Side Part (C3) to the unit with Head Cap Bolts and tighten. (see Figure 1)

Attach assembled drawer box in Step 1 to Left Unit and Right Unit with Head Cap Bolts.

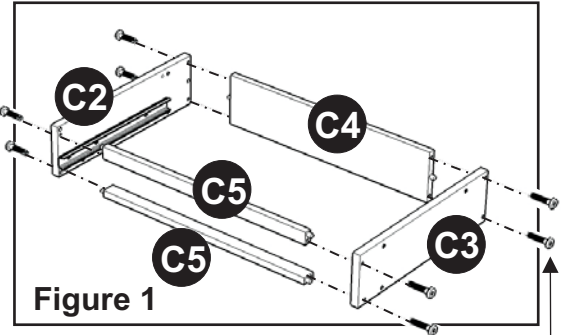
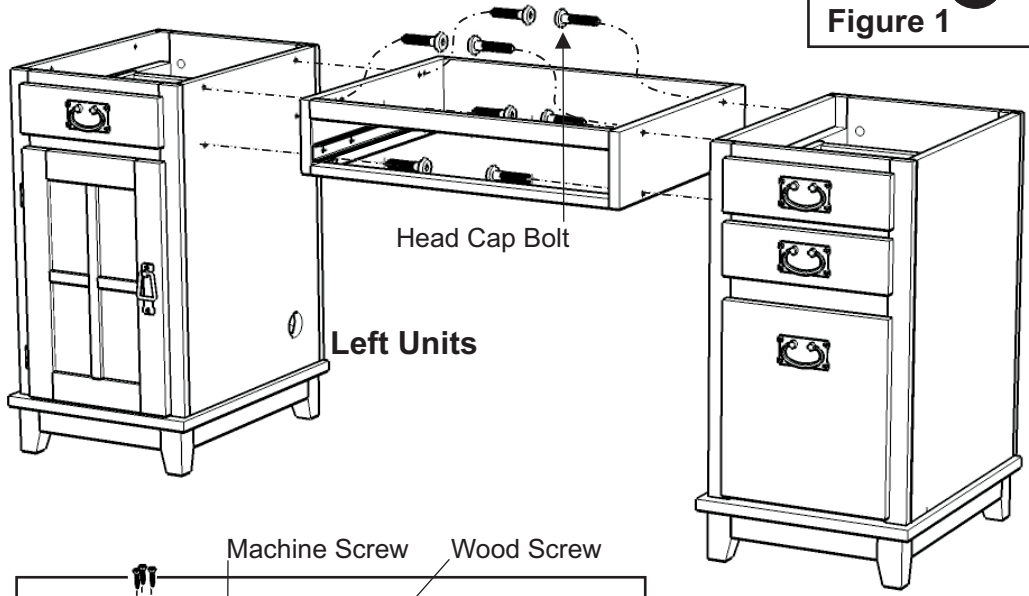

Figure 1

Head Cap Bolt



STEP 2

Attach Pull Handle to Front Part (B) with Machine Screws, then attach Front Part (B) to Base (C1) with Wood Screws.

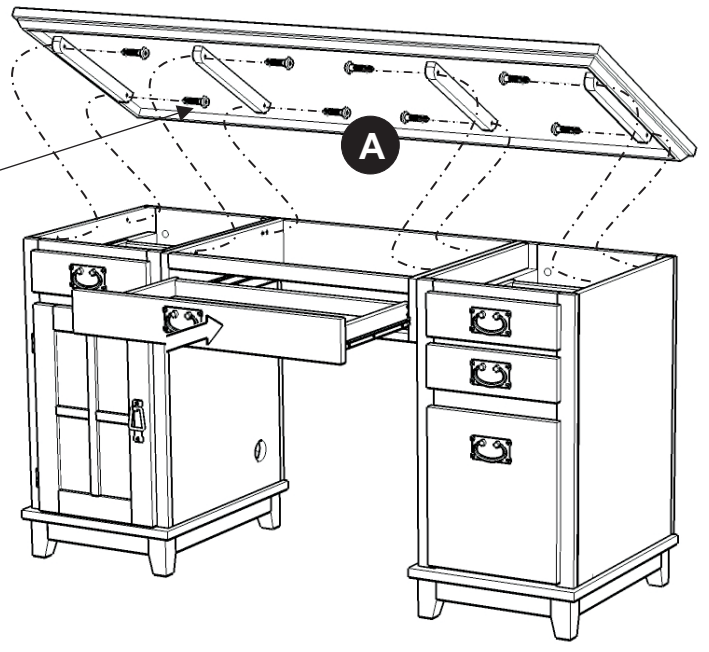
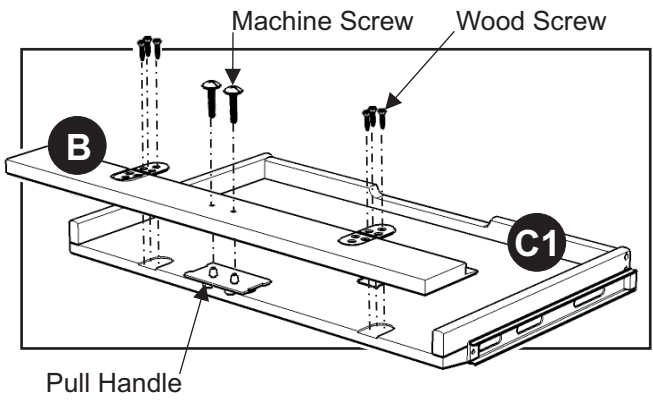

STEP 3

Place Top (A) on the unit with Head Cap Bolts. Slide drawer assembled in Step 2 into Place.